

# The Intrepid<sup>®</sup> II Woodburning Stove

Model 1990

## Homeowner's Installation and Operating Manual

For use in the  
United States and Canada

**SAFETY NOTICE: IF THIS APPLIANCE IS NOT PROPERLY INSTALLED, OPERATED AND MAINTAINED, A HOUSE FIRE MAY RESULT. TO REDUCE THE RISK OF FIRE, FOLLOW THE INSTALLATION INSTRUCTIONS. FAILURE TO FOLLOW INSTRUCTIONS MAY RESULT IN PROPERTY DAMAGE, BODILY INJURY OR EVEN DEATH. CONTACT LOCAL BUILDING OFFICIALS ABOUT RESTRICTIONS AND INSTALLATION INSPECTION REQUIREMENTS IN YOUR AREA.**

**NATIONAL  
FIREPLACE  
INSTITUTE**



[www.nficertified.org](http://www.nficertified.org)

We recommend that our woodburning hearth products be installed and serviced by professionals who are certified in the U.S. by the National Fireplace Institute<sup>®</sup> (NFI) as NFI Woodburning Specialists or who are certified in Canada by Wood Energy Technical Training (WETT).



**Do Not Discard This Manual: Retain for Future Use**

## Welcome

Congratulations on your choice of a Vermont Castings Intrepid II. With this purchase, you made a commitment to make the hearth a place of warmth, beauty and comfort in your home. At Vermont Castings Group, we share that joy and appreciation of the hearth, and we show it in all our cast iron stoves and fireplaces.

As you become acquainted with your new stove, you will find the aesthetic appeal of cast iron is matched only by its superb capacity to absorb and radiate heat.

Also, Vermont Castings Group products are among the cleanest burning wood stoves and fireplaces available today. As an owner of a Vermont Castings Group stove, you are making a strong statement for pollution-free energy. But clean burning depends on both the manufacturer and the operator. Please read this manual carefully to understand how to properly operate your stove.

At Vermont Castings Group, we are equally committed to your satisfaction as a customer and that is why we maintain an exclusive network of the finest dealers in the industry. Chosen for their expertise and dedication to customer service, our dealers are factory-trained and know each Vermont Castings Group product in detail. Feel free to contact your Authorized Vermont Castings Dealer anytime you have a question about your stove or its performance.

We have built your Vermont Castings Intrepid II with the utmost care. With normal use and proper care, it will provide you with many years of service.

This manual contains valuable instructions on the installation and operation of your Vermont Castings stove. You will also find useful information on assembly and maintenance procedures. We urge you to read the manual thoroughly and to keep it as a reference.

Sincerely,

***All of us at Vermont Castings Group***

This manual describes the installation, operation, and maintenance of the Vermont Castings Intrepid II Model 1990 catalytic-equipped wood burning heater. This heater meets the U.S. Environmental Protection Agency's emission limits for wood heaters sold on or after July 1, 1990. Under specific test conditions this heater has been shown to deliver heat at rates ranging from 8,200 to 26,700 Btu/hr.

The Intrepid II Model 1990 has been tested and is listed by Canadian Standards Association (CSA). The test standards are ANSI/UL-1482 and ANSI/UL-737 for the United States, and ULC S627 and CAN/CSA-B366.2 for Canada. The Intrepid II is listed for burning wood only. Do not burn other fuels. The Intrepid II is approved for use in manufactured (mobile) homes only in the United States, and only when installed with Vermont Castings Mobile Home Kit No. 3248.

Installation or service of this woodburning stove should only be completed by a qualified installer, preferably NFI or WETT (Canada) certified.

Please read this entire manual before you install and use your new stove. Failure to follow instructions may result in property damage, bodily injury, or even death.

**Save These Instructions for Future Reference**

## Table of Contents

Specifications .....	4
Installation .....	5
Clearances .....	14
Assembly .....	18
Operation.....	19
Draft Management.....	24
Maintenance .....	26
Catalytic Combustor .....	32
Replacement Parts .....	33
Warranty .....	39

Ask your Vermont Castings dealer how these installation accessories can enhance the versatility, appearance, and safety of your Intrepid Stove.

0307 Bottom Heat Shield

0172 Rear Heat Shield

Chimney connector heat shields

Heavy-gauge enamel pipe to match the stove's color

Warming shelves

0098 Classic Black	1377 Chestnut Brown
--------------------	---------------------

1372 Midnight Blue	1378 Ebony
--------------------	------------

1373 Brown Majolica	1379 Vt. Classic Green
---------------------	------------------------

1376 Biscuit	1380 Bordeaux
--------------	---------------

0136 Spark screen for open-fireplace use

Short Legs

0868 Classic Black	1530 Chestnut Brown
--------------------	---------------------

1515 Bordeaux	1535 Ebony
---------------	------------

1525 Suede Brown	1537 Vt. Classic Green
------------------	------------------------

1527 Biscuit	
--------------	--

3258 Outside air kit

3248 Mobile-home kit.

**Proposition 65 Warning:** Fuels used in gas, wood-burning or oil fired appliances, and the products of combustion of such fuels, contain chemicals known to the State of California to cause cancer, birth defects and other reproductive harm.  
California Health & Safety Code Sec. 25249.6

# Specifications

## Intrepid II, Model 1990

Range of heat output.....	8,260-26,740 Btu's/Hr <sup>3</sup>
Maximum heat output.....	27,000 Btu's/Hr <sup>1</sup>
Area heated.....	Up to 1200 sq. ft. (112 sq. m.) <sup>2</sup>
Fuel size/type.....	16" (410 mm) logs
EPA emissions rating (g/h, catalytic).....	2.1 <sup>3</sup>
Loading.....	Front or top
Chimney connector.....	6" (152 mm) diameter
Chimney flue size.....	6" (152 mm) minimum
Flue exit position.....	Reversible, top or rear
Primary air.....	Manual set, thermostatically maintained
Secondary air.....	Self-regulating
Ash handling system.....	Removable ash pan
Glass panels.....	High temperature ceramic
Weight.....	223 lbs. (101kg)
Width (leg-to-leg).....	21½" (545 mm)
Depth (leg-to-leg).....	13¾" (350 mm)
Height to top of flue collar:	
with regular legs.....	25" (635 mm) top exit
.....	24" (610 mm) rear exit
with optional short legs.....	21" (535 mm) top exit
.....	19¾" (500 mm) rear exit

1. This value can vary depending on how the stove is operated, the type and moisture content of the fuel used, as well as the design, construction and climatic location of your home. Figures shown are based on maximum fuel consumption obtained under laboratory conditions and on average efficiencies.
2. These values are based on operation in building code-conforming homes under typical winter climate conditions in New England. If your home is of nonstandard construction (e.g., unusually well insulated, not insulated, built underground, etc.) or if you live in a more severe or more temperate climate, these figures may not apply. Since so many variables affect performance, consult your Vermont Castings Authorized Dealer to determine realistic expectations for your home.
3. Under specific conditions used during EPA emissions testing.

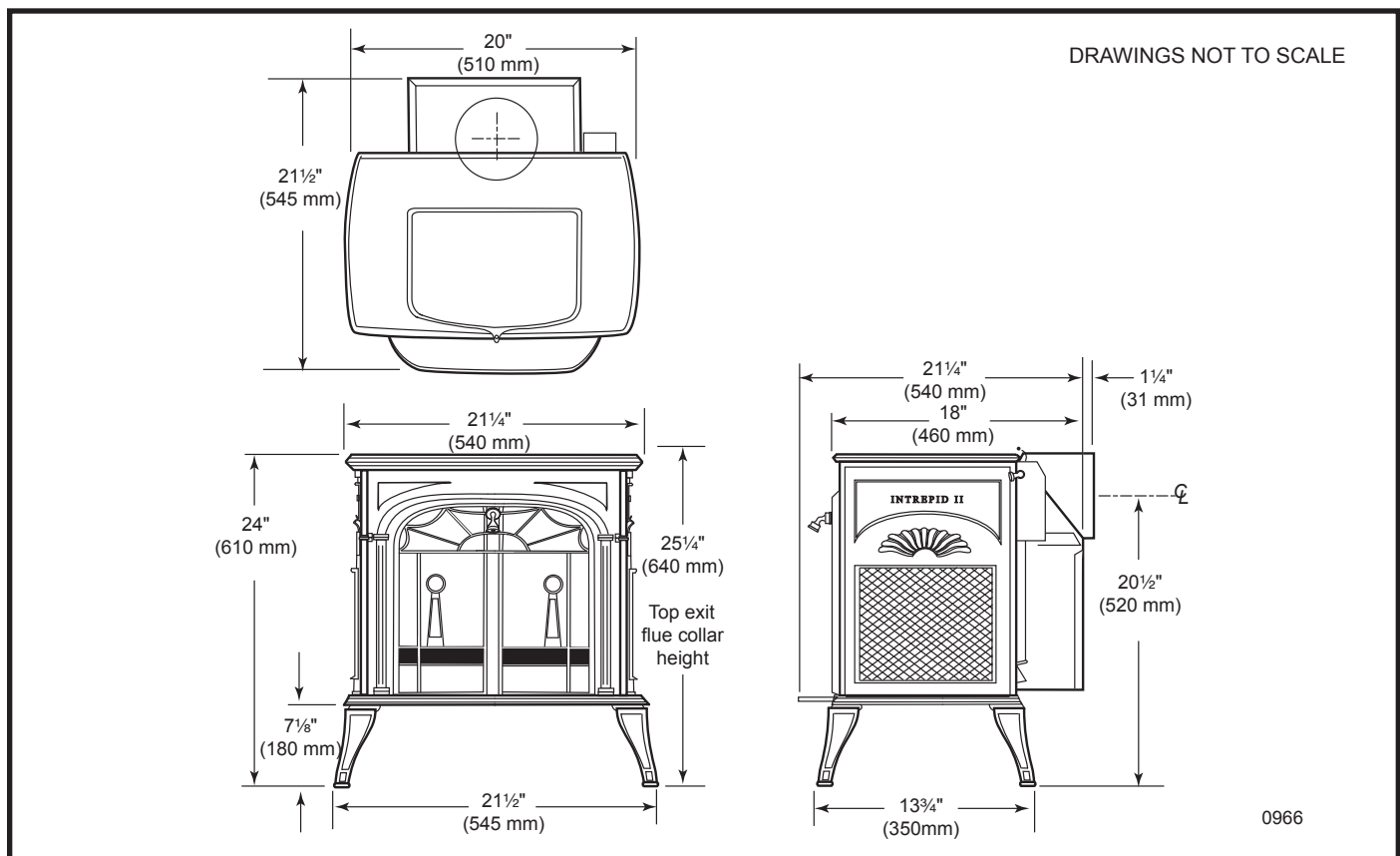


Fig. 1 Intrepid II 1990 dimensions.

# Installation

**SAFETY NOTICE: IF YOUR STOVE IS NOT PROPERLY INSTALLED, A HOUSE FIRE MAY RESULT. TO REDUCE THE RISK OF FIRE, FOLLOW THE INSTALLATION INSTRUCTIONS. CONTACT LOCAL BUILDING OR FIRE OFFICIALS ABOUT RESTRICTIONS AND INSTALLATION INSPECTION REQUIREMENTS IN YOUR AREA.**

Before you begin an installation, review your plans to see that:

- Your stove and chimney connector will be far enough from combustible material to meet all clearance requirements.
- The floor protector is large enough and is constructed properly to meet all requirements.
- You have all necessary permits from local authorities.

Your local building official is the final authority for approving your installation as safe and determining that it meets local and state codes.

The metal label permanently attached to the back of every Vermont Castings stove indicates the stove has been tested to current ULC standards, by Canadian Standards Association (CSA). The test standards are ANSI/UL-1482 and ANSI/UL-737 for the United States and ULCS627 and CAN/CSA-B366.2 for Canada. Clearance and installation information also is printed on the label. When the stove is installed according to the information both on the label and in this manual, local authorities in most cases will accept the label as evidence that the installation meets codes and can be approved.

However, codes vary in different areas. Before starting the installation, review your plans with the local building authority. Your local dealer can provide any additional information needed.

For any unresolved installation issues, refer to CSA CAN-B365 Installation Code for Solid Fuel Burning Appliances and Equipment. These standards are the basis for many national codes. They are nationally recognized and are accepted by most local authorities. Your local dealer or your local building official may have a copy of these regulations.

**IMPORTANT: FAILURE TO FOLLOW THESE INSTALLATION INSTRUCTIONS MAY RESULT IN A DANGEROUS SITUATION, INCLUDING A CHIMNEY OR HOUSE FIRE. FOLLOW ALL INSTRUCTIONS EXACTLY, AND DO NOT ALLOW MAKESHIFT COMPROMISES TO ENDANGER PROPERTY AND PERSONAL SAFETY.**

## Outside Air

In some modern, super-insulated homes, there is not enough air for combustion because of insufficient air infiltration into the building. Such air enters a home through unsealed cracks and openings. Kitchen or bath exhaust fans can compete with the stove for available air and compound the problem.

When poor draft is caused by a low infiltration rate, opening a ground floor window on the windward side of the house and in the vicinity of the stove will usually alleviate the problem.

Another solution is to install a permanent outside air supply to the stove and/or room. In some areas, in fact, bringing air for combustion from outside the home directly to the air inlet of the stove is required for new construction.

An outside air supply is not affected by pressure variations within the house, and improved stove performance often results. An Outside Air Adaptor Kit for the Intrepid II is available from your local Vermont Castings dealer.

## What Kind of Chimney to Use

Your Intrepid II must be connected to a code-approved masonry chimney with a flue liner, to a relined masonry chimney that meets local codes, or to a prefabricated metal chimney that complies with the requirements for Type HT chimneys in the Standard for Chimneys, Factory-Built, Residential Type and Building Heating Appliance, UL 103, or the High Temperature (650°C) Standard ULC S-629 for Canada. Whatever kind you use, the chimney and chimney connector must be in good condition and kept clean. Figure 2 shows the two chimney types.

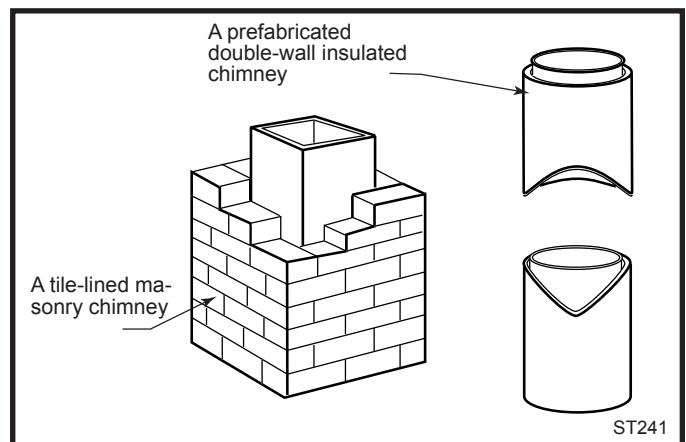


Fig. 2 Standard chimney types.

If you use an existing masonry chimney, it must be inspected to ensure safe condition before the stove is installed. Your local professional chimney sweep, building inspector, or fire department official will be able to inspect the chimney or provide a referral to someone who can.

The chimney must extend at least 3' (914 mm) above the highest point where it passes through a roof, and at least 2' (610 mm) higher than any portion of a building within 10' (3 m). (Fig. 3)

For proper draft and good performance, any chimney used with an Intrepid II should extend at least 16' (5 m) above the flue collar of the stove.

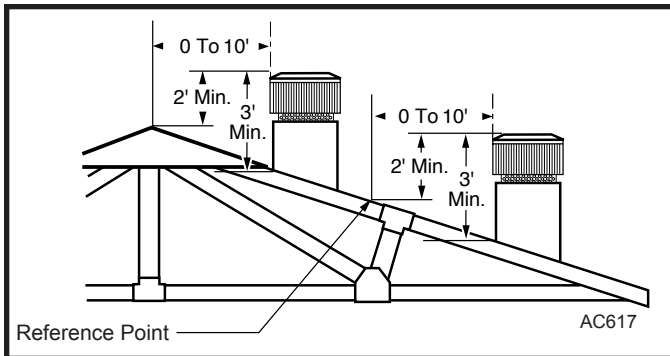


Fig. 3 The 2'-3'-10' Chimney Rule.

## Masonry Chimneys

An inspection of the chimney must confirm that it has a lining. Do not use an unlined chimney. The chimney should have no cracks, loose mortar, other signs of deterioration, or blockage. Repair any defects before using the chimney with your stove.

Seal any unused openings in an existing masonry chimney with masonry to the thickness of the chimney wall, and repair the chimney liner. Openings sealed with pie plates or wallpaper are a hazard; seal them with mortar or refractory cement. In the event of a chimney fire, flames and smoke may be forced out of these unused thimbles.

The chimney should be thoroughly cleaned before use.

A newly-built masonry chimney must conform to the standards of your local building code or, in the absence of a local code, to a recognized national code. Masonry chimneys must be lined, either with code-approved masonry or pre-cast refractory tiles, stainless steel pipe, or a code-approved, "poured-in-place" liner. The chimney's clean-out door must seal tightly.

## Prefabricated Chimneys

A prefabricated metal chimney must be one tested and listed for use with solid-fuel burning appliances to the High Temperature (650°C) Standard ULC S-629 for Canada.

**DO NOT CONNECT THIS UNIT TO A CHIMNEY FLUE SERVING ANOTHER APPLIANCE.**

## Chimney Size

An Intrepid II is approved for venting into a masonry chimney with a maximum flue size of 8" x 8" (203 x 203 mm), and into a round flue size of 6" (150 mm).

It may not be vented into larger chimneys without a liner to reduce the effective flue size to 6" (150 mm) diameter. Larger chimneys must have their flues relined for proper stove performance.

Accessories to make the connection between stainless steel chimney liners and your Intrepid II are available through your local dealer.

## Chimney Connector Guidelines

Chimney connector is the double-wall or single-wall pipe that connects the stove to the chimney. The chimney is a masonry or prefabricated structure that encloses the flue. Chimney connectors are used only to make the connection from the stove to the chimney.

Double-wall chimney connectors must be tested and listed for use with solid-fuel burning appliances. Single-wall chimney connectors should be made of 24 gauge or heavier steel, and should be 6" (150 mm) in diameter. Do not use galvanized connector; it cannot withstand the high temperatures that can be reached by smoke and gases, and may release toxic fumes under high heat.

If possible, do not pass the chimney connector through a combustible wall or ceiling. If passage through a combustible wall is unavoidable, refer to the section following on Wall Pass-Throughs. Do not pass the chimney connector through an attic, a closet, or any similar concealed space. The whole connector should be exposed and accessible for inspection and cleaning.

In horizontal runs of single-wall chimney connector without protective shields, maintain a clearance of at least 26" (660 mm) from the ceiling. For information on reduced clearances using shields on single-wall chimney connector or using double-wall connectors, see the clearance chart on Page 14.

Keep the horizontal run of chimney connector as short and direct as possible, with no more than two 90° turns. Slope horizontal runs of connector upward 1/4" per foot (20 mm per m) going from the stove toward the chimney. The recommended maximum length of a horizontal run is 3' (914 mm). The recommended total length of chimney connector is 8' (2.4 m).

In cathedral ceiling installations, extend the prefabricated chimney down to within 8' (2.4 m) of the stove.

**SAFETY NOTE: ALWAYS WEAR GLOVES AND PROTECTIVE EYEWEAR WHEN DRILLING, CUTTING OR JOINING SECTIONS OF CHIMNEY CONNECTOR.**



## Double-wall Chimney Connector

The listing for the Intrepid II for the U.S. and Canada includes use of double-wall chimney connectors that have been tested and listed for use with solid-fuel burning appliances by a recognized testing laboratory.

Information on assembling and installing double-wall connector is provided by the manufacturer of the double-wall pipe. Follow the manufacturer's instructions exactly as you assemble the connector and attach it to the stove and chimney. Using connectors and chimneys from the same manufacturer makes the assembly and installation straightforward.

**NOTE: For installations using double-wall connectors, minimum clearances must conform to the listed clearances in the clearance chart on Page 14.**

## Single-wall Chimney Connector

- Beginning at the flue collar of the stove, assemble the chimney connector. Insert the first crimped end into the stove's flue collar, and keep each crimped end pointing toward the stove. Using the holes in the flue collar as guides, drill 1/8" (3 mm) holes in the bottom of the first section of chimney connector and secure it to the flue collar with three #10 x 1/2" sheet metal screws.

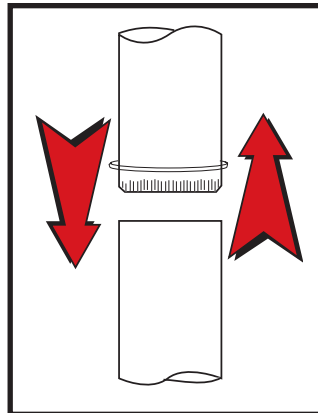
- Secure each joint between sections of chimney connector, including telescoping joints, with at least three sheet metal screws. The pre-drilled holes in the top of each section of chimney connector serve as guides when you drill 1/8" (3 mm) holes in the bottom of the next section.

- Secure the chimney connector to the chimney. Instructions for various installations follow.
- Be sure the installed stove and chimney connector are correct distances from nearby combustible material.

**NOTE:** Special slip pipes and thimble sleeves that form telescoping joints between sections of chimney connector are available to simplify installations. They often eliminate the need to cut individual connector sections. Consult your local dealer about these special pieces.

## Securing the Single-wall Connector to a Prefabricated Chimney

For prefabricated chimneys, follow the installation instructions of the chimney maker exactly as you install the chimney. The maker of the chimney will supply the accessories



**Fig. 4** The crimped end of the connector points toward stove.

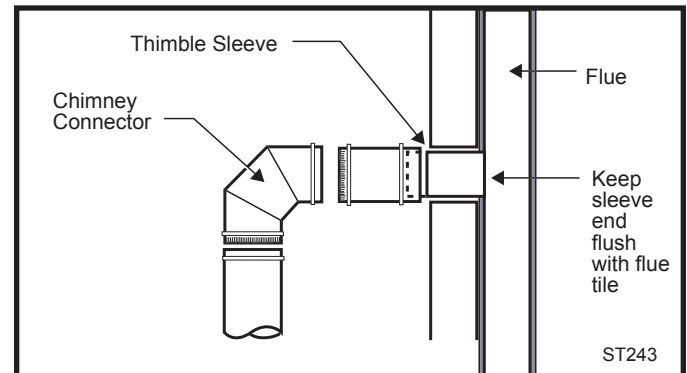
to support the chimney, either from the roof of the house, at the ceiling of the room where the stove is installed, or from an exterior wall.

Special adapters are available from your local dealer to make the connection between the prefabricated chimney and the chimney connector. The top of such adapters attaches directly to the chimney or to the chimney's ceiling support package, while the bottom of the adaptor is screwed to the chimney connector.

These adapters are designed so the top end will fit outside the inner wall of the chimney, and the bottom end will fit inside the first section of chimney connector. When assembled in this way, any soot or creosote falling from the inner walls of the chimney will stay inside the chimney connector.

## Securing the Single-wall Connector to a Masonry Chimney

For masonry chimneys, both freestanding and fireplace chimneys may be used for installation of your Intrepid II.



**Fig. 5** The thimble, made of either ceramic or metal, must be cemented securely in place.

## Freestanding Chimney Installations

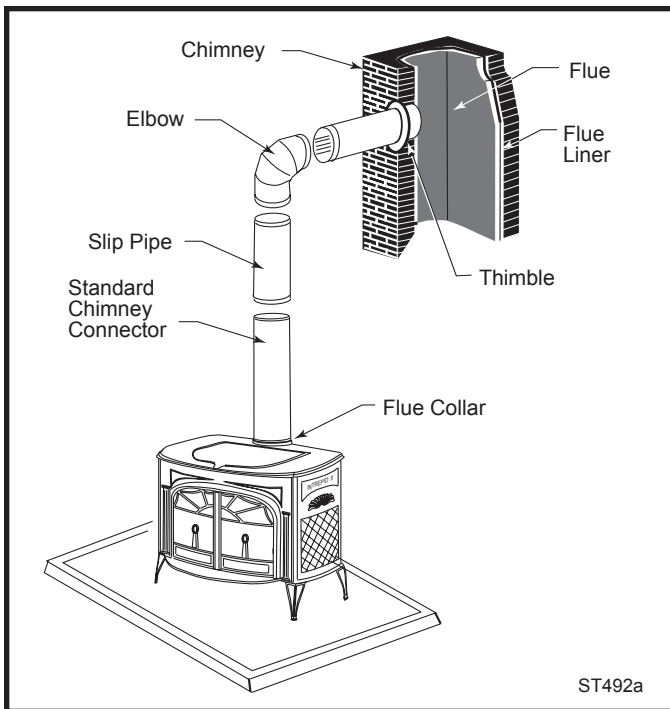
If the chimney connector must pass through a combustible wall to reach the chimney, follow the recommendations in the Wall Pass-through section that follows.

The opening through the chimney wall to the flue (the "breach") must be lined with either a ceramic or metal cylinder, called the "thimble", which is cemented firmly in place. The fit must be snug and the joint between the thimble and the chimney wall must be cemented. (Fig. 6)

A special piece called the "thimble sleeve," slightly smaller in diameter than standard connector and most thimbles, will facilitate the removal of the chimney connector system for inspection and cleaning. Thimble sleeves should be available from your local dealer. (Fig. 5)

To install a thimble sleeve, slide it into the breach until it is flush with the inner flue wall. Do not extend it into the actual flue passage, as this could interfere with the draft.

The thimble sleeve should protrude 1-2" (25-50 mm) into the room. Use furnace cement and thin gasketing to seal



**Fig. 6** Chimney connection in a freestanding installation.

the sleeve in place in the thimble. Secure the chimney connector to the outer end of the sleeve with sheet metal screws.

Without a thimble, a suitable length of chimney connector can be extended through the breach to the inner face of the flue liner, and cemented securely in place. Additional pieces of connector are then attached with sheet metal screws.

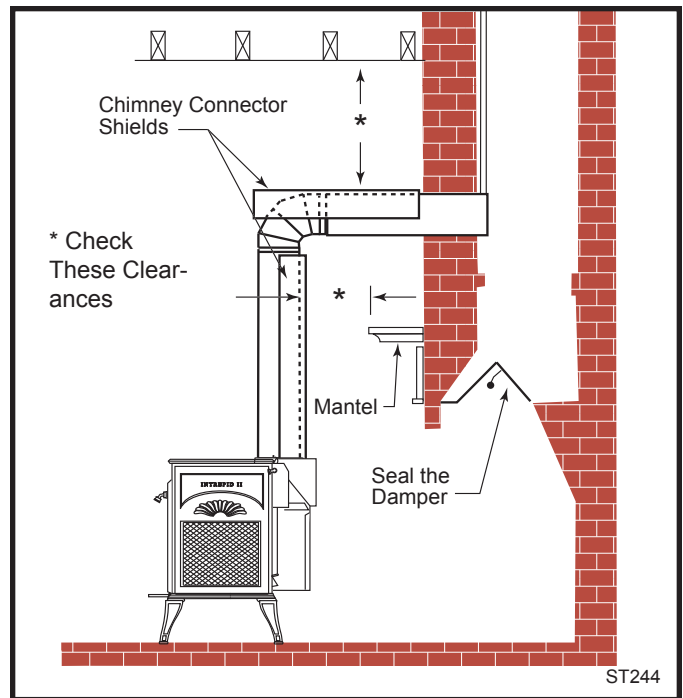
### Fireplace Chimney Installations - Above a Fireplace

The Intrepid II may be connected to a chimney above a fireplace opening also. In such installations, the stove is positioned on the hearth in front of the fireplace and the chimney connector rises from the stove top and then angles ninety degrees back into the chimney. (Fig. 7)

The chimney liner should extend to the point at which the chimney connector enters the chimney.

If the chimney connector from your installation enters the chimney above a fireplace, follow all the guidelines mentioned above for freestanding installations. In addition, give special consideration to the following points:

- Check the clearance between the stove and the chimney connector, and any combustible trim or the mantel. Use the necessary combination of mantel, trim, and connector heat shields to achieve the required clearances.
- Check the clearance between the chimney connector and the ceiling. If no heat shields are used, the clearance should be at least 26" (660 mm). To find out how much this clearance may be reduced with heat shields, refer to the clearance chart on Page 14.



**Fig. 7** Chimney connector enters chimney above the fireplace.

- The fireplace damper must be sealed to prevent room air from escaping up the flue. However, it must be possible to re-open the damper to inspect or clean the chimney.

### Fireplace Chimney Installations - Through a Fireplace

If your fireplace height is at least 25" (635 mm), you may install an Intrepid II with standard legs through the fireplace opening using a "positive connection" kit available from your local dealer. These positive connection kits ensure a tight fit between the stove flue collar and the chimney flue. (Fig. 8) Fireplace installations, whether connected to the flue above or through the fireplace opening, have special clearance requirements to adjacent trim and the mantel. You'll find the required clearances for the Intrepid II fireplace installations on Page 14.

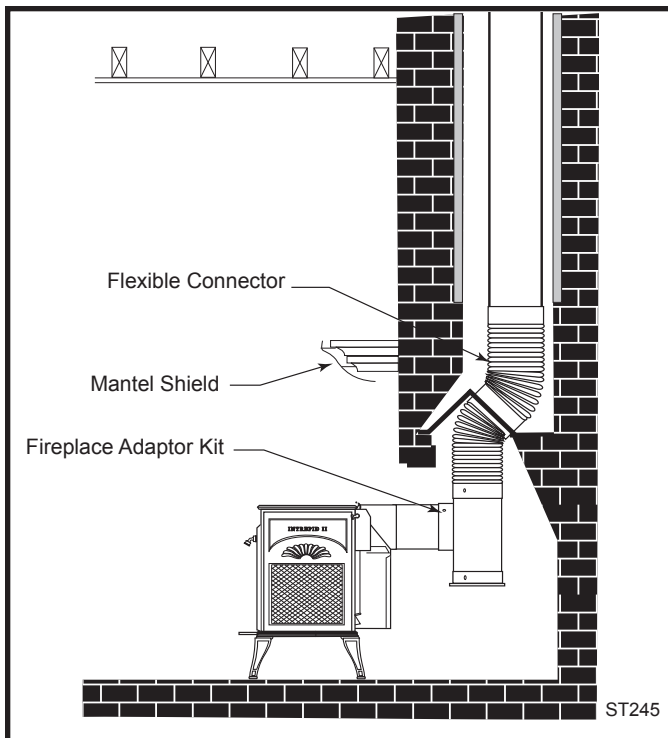
Floor protection requirements also apply to fireplace installations. Floor protection information is on Page 9.

### Wall Pass-Throughs

Whenever possible, design your installation so the connector does not pass through a combustible wall. If you are considering a wall pass-through in your installation, check with your building inspector before you begin. Also, check with the chimney connector manufacturer for any specific requirements.

Accessories are available for use as wall pass-throughs. If using one of these, make sure it has been tested and listed for use as a wall pass-through.

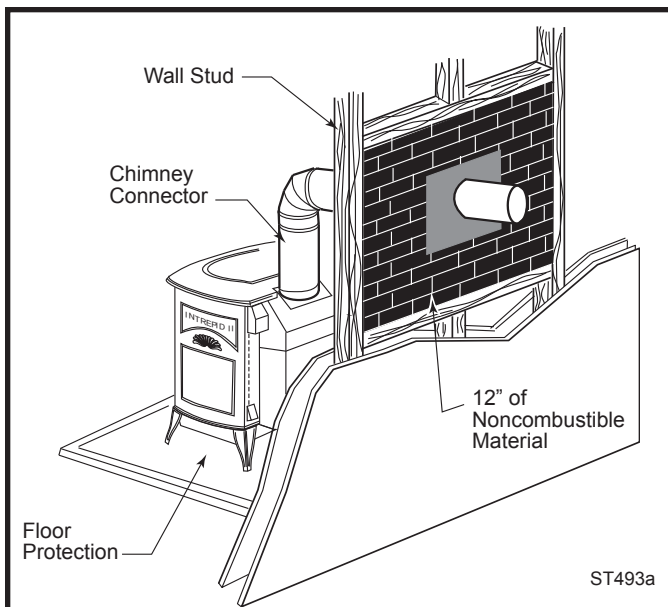




**Fig. 8** Chimney connector enters chimney through the fireplace opening.

**In the United States**, the National Fire Protection Association (NFPA) has established guidelines for passing chimney connectors through combustible walls. Many building code inspectors follow these guidelines when approving installations.

Figure 9 shows one NFPA-recommended method. All combustible material in the wall is cut away from the single-wall connector to provide the required 12" (305 mm) clearance. Any material used to close up the opening must be noncombustible.



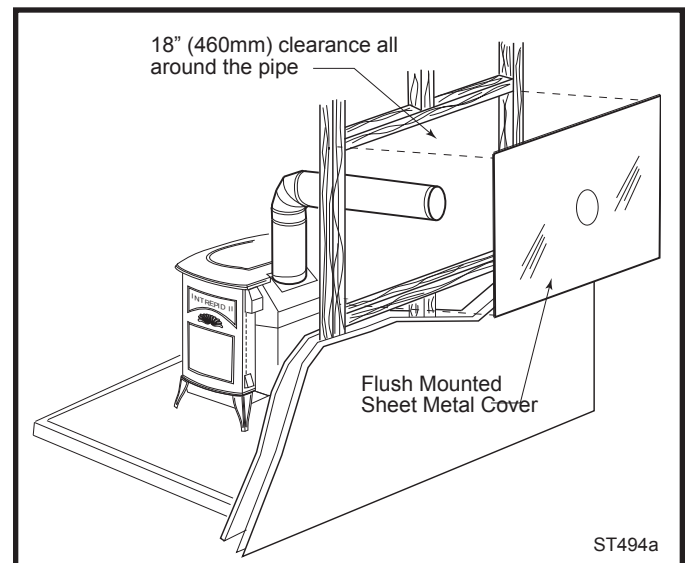
**Fig. 9** An approved wall pass-through for the United States.

Three other methods are also recommended by NFPA:

- Using a section of double-wall chimney with a 9" (230 mm) clearance to combustibles.
- Placing a section of chimney connector inside a ventilated thimble, which in turn is separated from combustibles by 6" (150 mm) of fiberglass insulating material.
- Placing a section of chimney connector inside a section of 9" (230 mm) diameter, solid-insulated, factory-built chimney, with 2" (50 mm) of air space between the chimney section and combustibles.

**In Canada**, The Canadian Standards Association has established installation guidelines. The following illustration shows one method, in which all combustible material in the wall is cut away to provide the required 18" (460 mm) clearance for the connector. The resulting space must remain empty. A flush-mounted sheet metal cover may be used on one side only. If covers must be used on both sides, each cover must be mounted on noncombustible spacers at least 1" (25 mm) clear of the wall.

Your local dealer or your local building inspector can provide details for other approved methods of passing a chimney connector through a combustible wall in your area. In Canada, this type of installation must conform to CAN/CSA-B365, Installation Code for Solid Fuel Burning Appliances and Equipment.



**Fig. 10** An approved wall pass-through for Canada.

**NOTE:** Do not vent your Intrepid II into a factory-built (zero-clearance) fireplace. These appliances and their chimneys are specifically designed as a unit for use as fireplaces. It may void the listing or be hazardous to adapt them for any other use.

**DO NOT CONNECT AN INTREPID II TO ANY AIR DISTRIBUTION DUCT OR SYSTEM.**

## Floor Protection

A tremendous amount of heat radiates from the bottom plate of an Intrepid II, and the floor beneath requires two kinds of special protection.

Heat protection is provided by a Bottom Heat Shield, part #0307.

Spark and ember protection is provided by a floor protector, which may be any noncombustible material.

For a new hearth, we recommend a noncombustible floor protector such as 1/4" non-asbestos mineral board or its equivalent, or 24 gauge sheet metal. If carpeting is present, it must be removed before installation of the floor protector. The floor protector may be covered with a noncombustible decorative material if desired. When using brick, tile, or stone, individual pieces must be mortared so sparks cannot fall through.

**Most installations will require that the bottom heat shield be attached. Only when the stove is placed on a completely noncombustible surface, such as unpainted concrete over earth, may it be used without the bottom heat shield.**

Even with the bottom heat shield installed, you must also use a floor protector.

**In the United States**, the floor protector required under the stove must extend at least 16" from the front of the stove - not from the ashlip - (Labeled 'E' in Fig. 11), and at least 6" from the sides and rear ('D', Fig. 11).

To meet the requirement in the United States, a floor protector must be at least 34" wide and 40" deep.

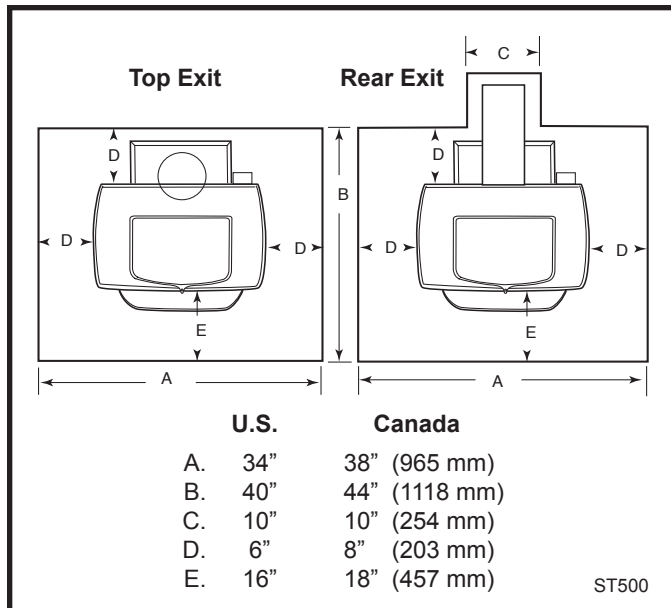


Fig. 11 Required floor protector dimensions.

**In Canada**, the floor protector required under the stove must extend 18" (460 mm) to the front (labeled 'E', Fig. 11), and 8" (203 mm) from the sides and rear. ('D', Fig. 11)

To meet Canadian requirements, a floor protector must be at least 38" (965 mm) wide and 44" (1118 mm) deep.

Floor protection also must extend under the chimney connector and 2" (51 mm) to either side. ('C', Fig. 11) For 6" (152 mm) connector used with the Intrepid II, the protector must be a minimum of 10" (254 mm) wide, centered under the connector.

## Floor Protection for Fireplace Installations

Do not assume your fireplace hearth is completely noncombustible.

Many fireplace hearths do not satisfy the "completely noncombustible" requirement because the brick or concrete in front of the fireplace opening is supported by heavy wood framing as in Figure 12. Because heat passes through brick or concrete readily, it can easily pass through to the wood. As a result, such fireplace hearths can be a fire hazard and are considered a combustible floor.

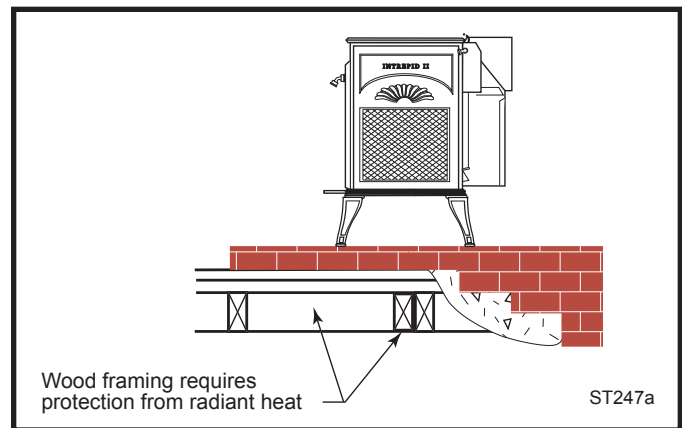


Fig. 12 Supporting timbers under fireplace hearth are considered to be combustible.

Keep in mind that many raised hearths will extend less than the required clearance from the front of the heater when it is installed. In such cases, sufficient floor protection as described above must be added in front of the hearth to satisfy the minimum floor protector requirement from the front of the stove: 18" (460mm) from the front in Canada. Fireplace hearths must also offer the required protection of 8" (203 mm) on either side.

Optional 3" (76 mm) short legs may be used only on such hearths that meet the width and depth requirements outlined previously under "floor protection."

Hearth rugs do not satisfy the requirements for floor protection.

Fireplace installations also have special clearance requirements to the side walls, side decorative trim, and fireplace mantel. Refer to the information on fireplace and mantel trim shields in this section.

## Keep the Stove and Connector a Safe Distance from Surrounding Materials

Both a stove and its chimney connector radiate heat in all directions when operating, and dangerous overheating of nearby combustible materials can occur if they are too close to the heat. A safe installation requires that adequate clearance be maintained between the hot stove and its connector and nearby combustibles.

Clearance is the distance between either your stove (measured from the back edge of the stove's top plate) or chimney connector, and nearby walls, floors, the ceiling, and any other fixed combustible surface. Your stove has special clearance requirements that have been established after careful research and testing to UL and ULC standards. These clearance requirements must be strictly observed.

In addition, furnishings and other combustible materials must be kept away from the stove as well. In general, a distance of 48" (1220 mm) must be maintained between the stove and moveable combustible items such as drying clothes, furniture, newspapers, firewood, etc. Keeping those clearance areas empty assures that nearby surfaces and objects will not overheat.

## Reducing Clearances

Stove clearances may be reduced by using heat shields attached to the stove. Chimney connector clearances may be reduced by using heat shields on single-wall connector, or by using double-wall connector. Clearances may also be reduced by using wall shields. All shielding used to reduce clearances must be listed by a recognized testing laboratory and approved by the local regulatory body.

Clearance requirements are established for many different installations. In general, the greatest clearance is required when you are placing a stove and its connector with no heat shields near a wall with no heat shield.

For example, when the Intrepid II is installed parallel to the rear wall and no shielding is used, it must be at least 30" (760 mm) from the wall behind it and at least 24" (610 mm) from walls on either side.

If the Intrepid II is installed in a corner and no shields are used, the corners of the stove must be at least 20" (510 mm) from nearby walls.

The least clearance is required when both the stove and its connector, as well as the wall, have heat shields.

When shields are attached to the stove or chimney connector, they are mounted 1" - 2" (25-51 mm) away from the stove or connector surface on non-combustible spacers. Air flowing between the stove (and/or chimney connector) and nearby shields carries away heat. Do not block the air flow by filling this empty space with any insulating material.

The shiny shield surface facing the heat source must be left unpainted, enabling it to reflect heat back towards the stove or connector and away from the wall.

Shields are never used on double-wall connectors.

Clearances may be reduced only by means approved by the regulatory authority, and in accordance with the clearances listed in this manual.

**NOTE: ALCOVE INSTALLATION OF THE INTREPID II IS NOT PERMITTED IN CANADA.**

## Stove Heat Shields

The Intrepid II Rear Heat Shield is one way to reduce the clearance to the rear wall. The rear heat shield may be installed on either rear- or top-exiting stoves. However, since the chimney connector also radiates heat toward the wall in top-exiting installations, either single-wall connector with connector heat shields, or listed and approved double-wall chimney connector should be used whenever the rear heat shield is used on top-exiting stoves.

Clearance reductions with the rear heat shield apply only to the wall to the rear in parallel installations. Neither the side clearance requirement nor the clearance requirement in corner installations may be reduced.

## Wall Shields

Clearances may be reduced by using a wall shield constructed of 24 gauge or heavier sheet metal, or of another non-combustible material such as 1/2" (13 mm) insulation board or common brick "laid on flat," with the 3 1/2" (90 mm) side down. Figure 13 shows such a wall shield.

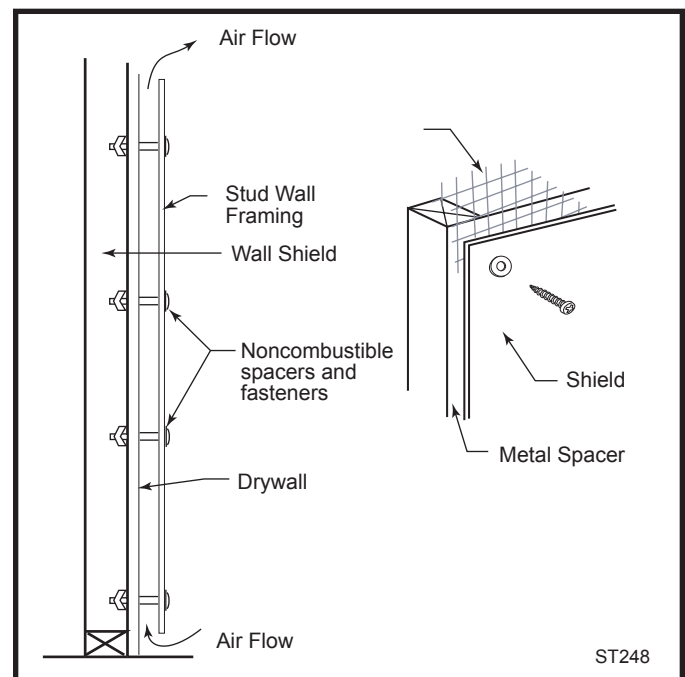


Fig. 13 Approved wall shield construction.

Shields must be spaced out from the combustible surface 1" (25 mm) on noncombustible spacers. The spacers should not be directly behind the stove or chimney connector.

Air must be able to flow between the wall and the shield. At least 50% of the bottom 1" (25 mm) of the shield should be open and the shield must be open at the top. (Fig. 13)

The wall shield for a stove must extend 10" (254 mm) above the top of the stove, or a height of 35" (890 mm). The wall shield for the chimney connector must be 36" (914 mm) wide, centered behind the connector; for installations that use an approved prefabricated chimney to pass through the ceiling, the chimney connector shield used with single-wall connector must stop 1" (25 mm) below the ceiling.

### Chimney Connector Clearance Reductions

Chimney connector clearances may be reduced by using heat shields on single-wall connector or by using double-wall connector. One of these methods should be used whenever the rear heat shield is used in top-exit installations, or in any other situation when it is necessary to protect nearby combustibles from the heat of the chimney connector. The ceiling above horizontal runs of chimney connector must be protected as well if the clearance is inadequate. Refer to the Clearance Charts.

In top-exiting installations in which the single-wall connector extends to the ceiling and connects to a prefabricated insulated metal chimney, the connector shield must extend to within an inch of the ceiling. A ceiling heat shield must be installed that is 22" (560 mm) in diameter and, as explained above, that extends 1" (25 mm) below the ceiling. The ceiling shield must be constructed of 24 gauge or heavier sheet metal, must be centered on the chimney, and must meet any wall protector that is also a part of the installation.

**For double-wall connector the tested and listed clearances given in this manual must be used.**

### Fireplace and Mantel Trim Shields

A fireplace installation requires special clearance between the side of the stove and the right and left walls, between the side of the stove and the decorative side trim on the fireplace face, and between the top of the stove and the mantel.

Noncombustible shields installed 1" (25 mm) away from the combustible surface on noncombustible spacers, called ventilated shields, may be used to reduce clearances. (Fig. 14)

To protect a mantel from the heat of an Intrepid II in a fireplace installation, the ventilated mantel shield must be at least 48" (1220 mm) long, and it must be centered over the stove. Ventilated shields for side trim must extend the full length of the trim.

An unprotected mantel ('A', Fig. 15) cannot be more than 9" (230 mm) deep and must have a minimum clearance of 30" (760 mm), measured from the stove's top plate. With

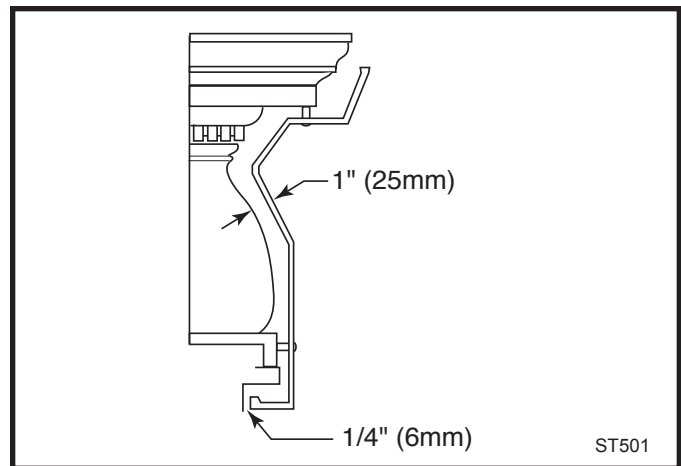


Fig. 14 A custom-formed mantel shield.

ST253

**Fireplace Mantel and Trim Clearances**  
Measured from the top and sides of the stove

	Unprotected	Protected
A. Mantel	30" (762 mm)	14" (356 mm)
B. Top Trim	24" (610 mm)	14" (356 mm)
C. Side Trim	15" (381 mm)	10" (254 mm)

Fig. 15 Maintain clearances to combustible components of the mantelpiece.

a ventilated shield, this clearance may be reduced safely to 14" (360 mm).

Unprotected top trim (B) protruding 2" (50 mm) or less from the face of the fireplace must be a minimum of 24" (610 mm) from the stove's top surface. With a ventilated trim shield, this clearance may be reduced safely to 14" (360 mm).

Unprotected side trim (C) that protrudes 2" (50 mm) or less from the face of a fireplace must have a minimum clearance of 15" (380 mm), measured from the stove's top side edge. With a ventilated trim shield, the clearance may be reduced safely to 10" (254 mm). If the trim extends more than 2" (51 mm), wall clearance requirements apply.



The charts and sample installations that follow list the clearances required for the various installation configurations of the Intrepid II.

### Alcove Installations

Because of their restricted air flow and heat retention characteristics, specific construction requirements and special clearances apply to installations into alcoves. No stove or chimney connector heat shields are used in alcove installations.

**ALCOVE INSTALLATION OF THE INTREPID II IS NOT PERMITTED IN CANADA.**

### Construction Requirements

The following illustrations show noncombustible ceiling framing and maximum and minimum permitted dimensions for alcove construction.

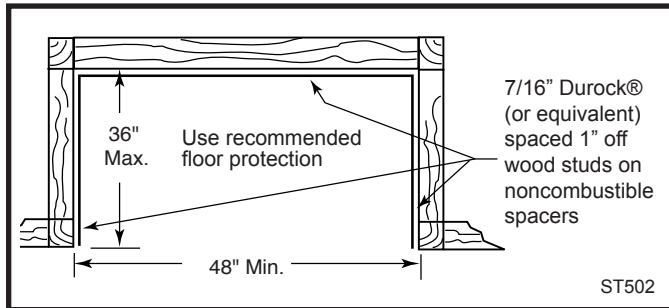


Fig. 16 Alcove floor plan. Sheetrock on front face butts to Durock® (or equivalent) alcove lining.

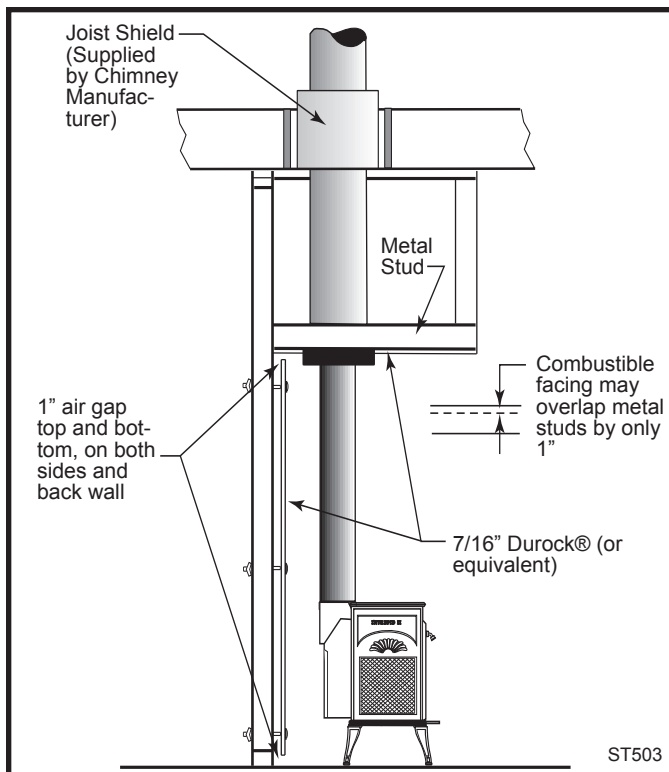


Fig. 17 Alcove side section.

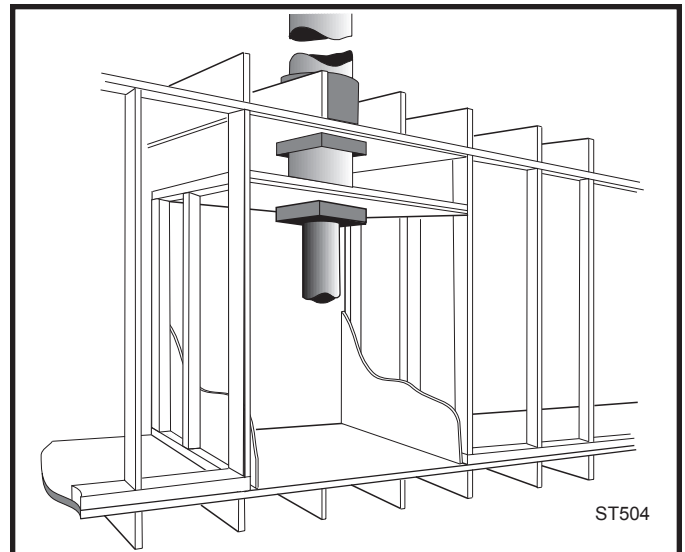


Fig. 18 Cutaway perspective of alcove installation.

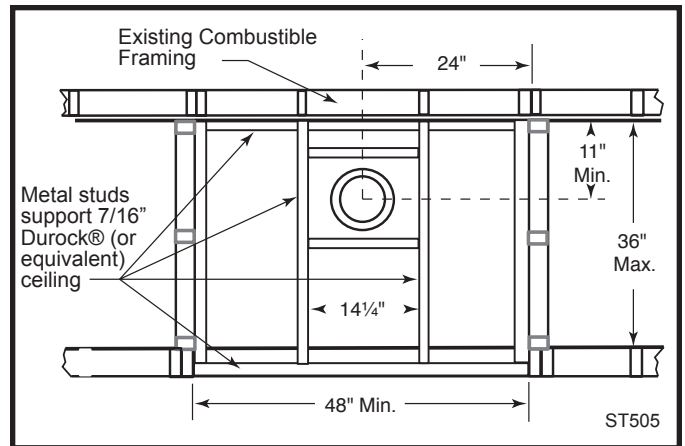


Fig. 19 Reflected ceiling plan.

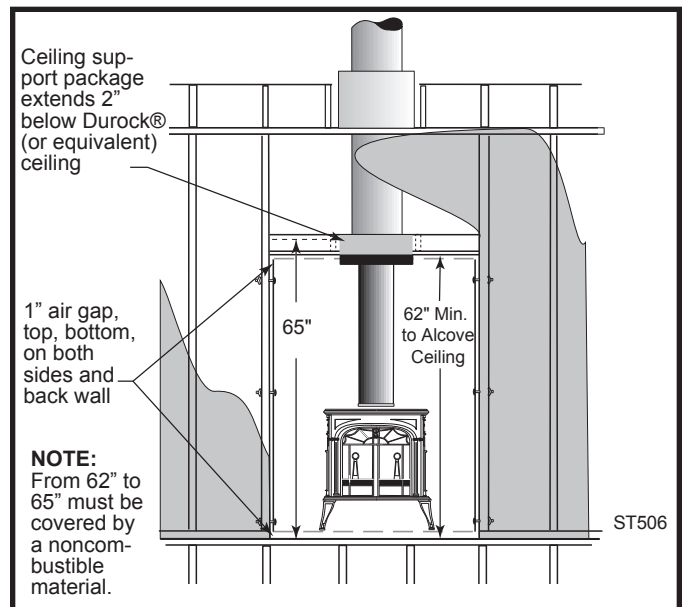


Fig. 20 Front view: 65" minimum clearance from hearth to combustibles on front face. Combustible facing may overlap metal studs by only 1". It should not extend below the height of the noncombustible ceiling.



## Intrepid II Clearance Chart

See Pages 15 and 16 for illustrations of these clearances.

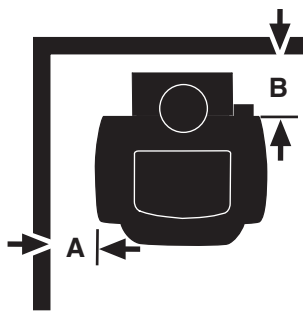
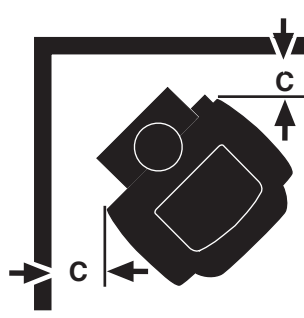
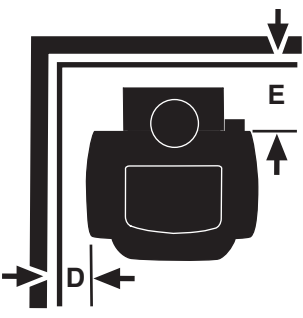
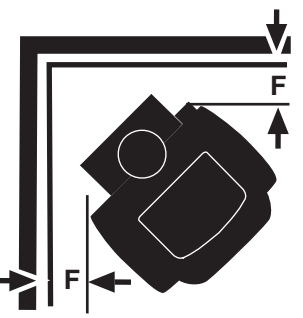
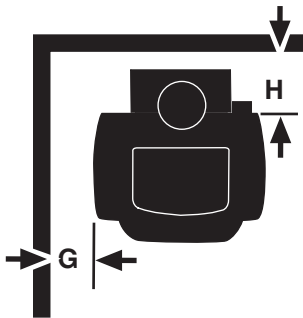
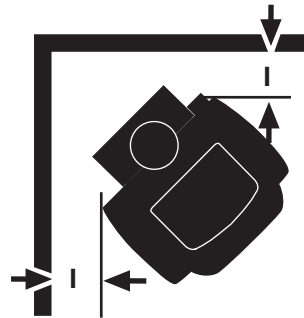
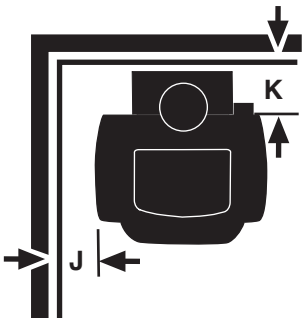
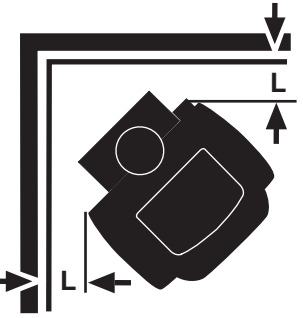
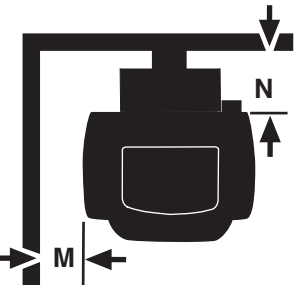
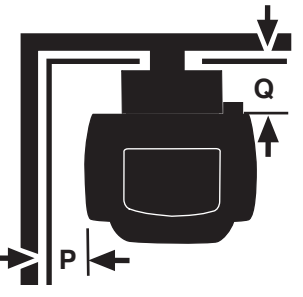
	Unprotected Surfaces			Protected Surfaces		
	<b>Stove Clearance</b>					
	Stove Installed Parallel to Wall		Stove in Corner	Stove Installed Parallel to Wall		Stove in Corner
	Side	Rear	Corners	Side	Rear	Corners
No stove heat shields	(A) 24" (610 mm)	(B) 30" (762 mm)	(C) 20" (508 mm)	(D) 12" (305 mm)	(E) 16" (406 mm)	(F) 10" (254 mm)
Top exit, rear stove h.s., single-wall chimney connector with connector heat shields <sup>1,2</sup>	(G) 24" (610 mm)	(H) 16" (406 mm)	(I) 12" (305 mm)	(J) 12" (305 mm)	(K) 9" (229 mm)	(L) 10" (254 mm)
Rear exit, rear stove heat shield <sup>3</sup>	(M) 24" (610 mm)	(N) 14" (356 mm)	n/a	(P) 12" (305 mm)	(Q) 9" (229 mm)	n/a
Top exit, rear stove h.s., double-wall chimney connector <sup>5</sup>	(G) 24" (610 mm)	(H) 16" (406 mm)	(I) 12" (305 mm)		*	
<b>Chimney Connector Clearance</b>						
Single-wall chimney connector, no connector heat shields	26" (660 mm)			12" (305 mm)		
Single-wall chimney connector, with connector heat shields	10" (254 mm)			5" (127 mm) <sup>4</sup>		
Double-wall connector <sup>5</sup>	12" (305 mm)			*		
<b>Front Clearance to Combustibles</b>						
All Installations				48" (1219 mm)		

\* Clearances with double-wall connectors and protected surfaces have not been tested for the Intrepid II.

1. Shielding for a top exit stove must include the stove rear heat shield insert to protect the area behind the flue collar.
2. Chimney connector heat shields, in an installation that goes through a combustible ceiling, must extend to 1" (25 mm) below the ceiling heat shield, which is 22" (559 mm) in diameter. The ceiling heat shield should be 24 gauge or heavier sheet metal, centered on the chimney connector, and mounted on noncombustible spacers.
3. Rear exit—horizontal from flue collar directly back through wall.
4. The ceiling heat shield required when chimney connector shields are used should meet the wall protector. This will require trimming the ceiling shield along the line of intersection with the wall protector.
5. In top exit installations, this clearance requires the use of the rear heat shield with the shield insert installed.

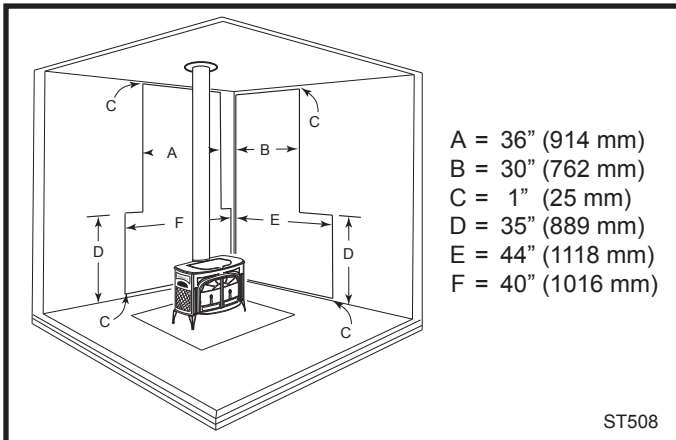
## Intrepid II Clearance Diagrams

See the chart on Page 14 for dimensions indicated by letter in the diagrams below.

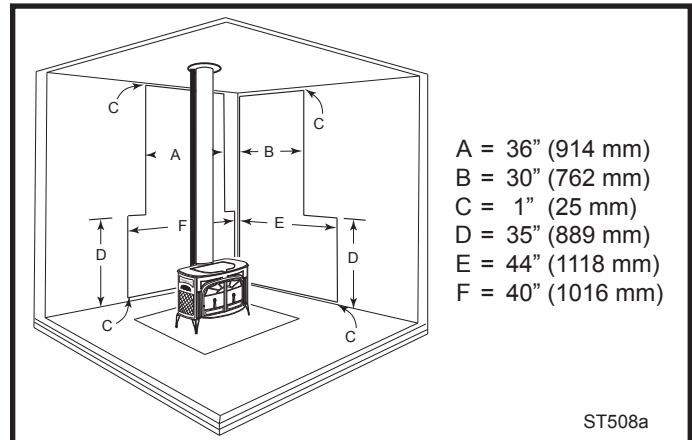
Unprotected Surfaces		Protected Surfaces	
Stove Installed Parallel to Wall	Stove in Corner	Stove Installed Parallel to Wall	Stove in Corner
Top Exit Installations, no heat shields			
			
Top Exit Installations, rear heat shield, and chimney connector heat shields or double-wall connector			
			
Rear Exit Installations, rear heat shields.			
	N/A		N/A

ST507

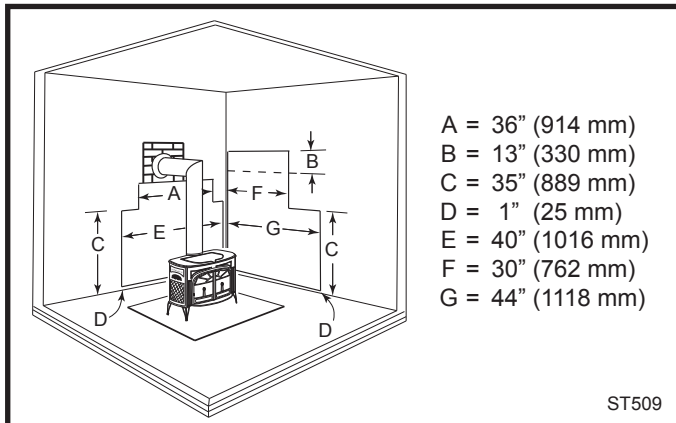
## Wall Shield Requirements for Some Common Intrepid II Installations



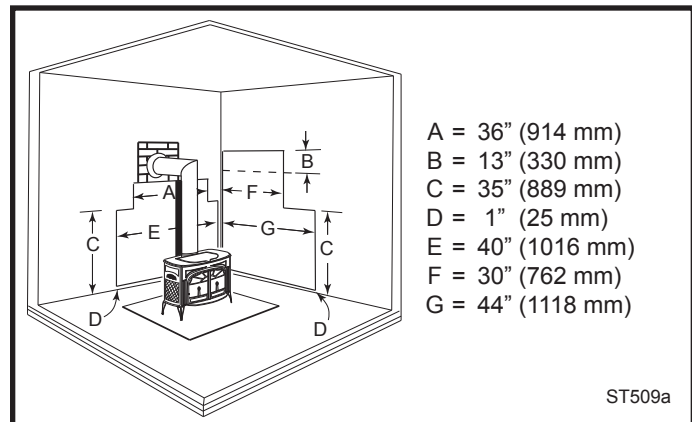
**Fig. 21** Parallel installation, vertical chimney connector, two wall shields. Reduced clearances for both rear and side walls. Wall shields may meet at corner if desired. Shielding for connector is centered behind connector.



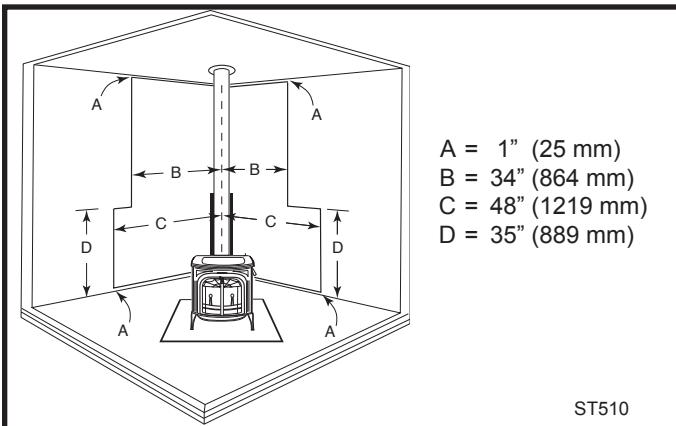
**Fig. 24** Parallel installation, vertical chimney connector, with stove, connector and wall shields. Maximum reduction for rear and side walls. Wall shields may meet at corner. A heat shield 24" (610mm) in diameter suspended 1" (25mm) below the ceiling must surround the chimney.



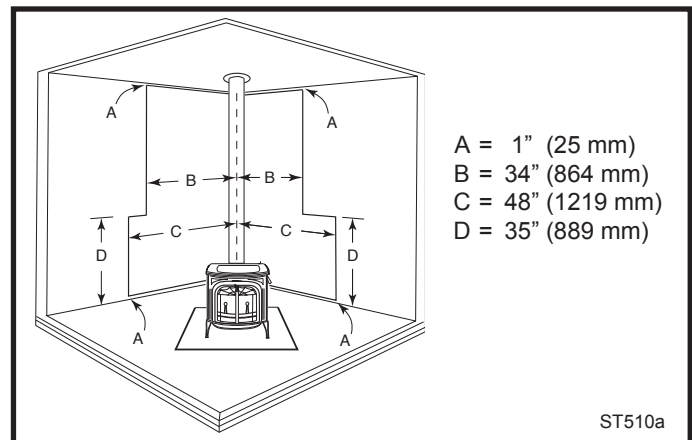
**Fig. 22** Parallel installations with rear wall pass-through, two wall shields. Reduced clearances for both rear and side walls. Wall shields may meet at corner if desired. Shielding for connector is centered behind connector. Wall pass-through must comply with codes.



**Fig. 25** Parallel installation with rear wall pass-through, with stove, connector and wall shields. Wall shields may meet at corner. Connector heat shield extends 28" (710mm) above flue collar, or below elbow, whichever is less. Wall pass-through must comply with codes.



**Fig. 23** Corner installation, vertical chimney connector, with rear, stove, connector and wall shields. Wall shields **MUST** meet at corner. Connector heat shield extends 28" (710mm) above flue collar. A 24" (610mm) diameter ceiling heat shield must surround the chimney and be suspended 1" (25mm) from ceiling.



**Fig. 26** Corner installation, vertical chimney connector, two wall shields. Reduced side clearances. Wall shields **MUST** meet at corner.

## Distance from the Center of the Flue Collar to the Wall in Top-Exit Installations

The information on this page is helpful in planning stove placement for top-exiting installations, particularly those installations with chimneys that pass through the ceiling. However, this is not a clearance chart. Final stove clearances must adhere to the guidelines stated in the clearance charts on Page 14.

Intrepid II: WITHOUT Stove and Chimney Connector Heat Shields					
Unprotected Surfaces			Protected Surfaces		
Parallel Installations		Corner Installations**	Parallel Installations		Corner Installations**
Side (A)	Rear (B)	Corner (C)	Side (D)	Rear (E)	Corner (F)
34¾" (883 mm)	29" (737 mm)	26¾" (680 mm)	22¾" (578 mm)	15" (381 mm)	16¾" (426 mm)

\* This distance, from the center of the flue collar to the front edge of the hearth, is the same for all installations on this page: 31" in the United States and 33" (840mm) in Canada.

Intrepid II: WITH Stove and Chimney Connector Heat Shields					
Unprotected Surfaces			Protected Surfaces		
Parallel Installations		Corner Installations**	Parallel Installations		Corner Installations**
Side (A)	Rear (B)	Corner (C)	Side (D)	Rear (E)	Corner (F)
34¾" (883 mm)	15" (381 mm)	18¾" (476 mm)	22¾" (578 mm)	8" (203 mm)	16¾" (426 mm)

\*\* To locate center of flue collar for corner installation, add 7" (180mm) to the clearance distance from stove corner to wall. Mark off the resulting distance from the corner along both walls. Next, measure the same distance from these two points out from the walls. These last two measurements will meet at a point representing the center of the flue collar. Refer to the diagrams above.

## Assembly

### Clean the Griddle Before Use

At the factory the griddle is coated with vegetable oil to prevent rusting while the stove is in transit and storage. Remove the oil with a dry rag or paper towel before you use the stove.

### Set Up the Stove

Remove any loose parts from inside the stove. Place a protective pad on the floor, arrange some sections of 4 x 4 lumber on the pad for support, and carefully tip the stove onto them, on its back.

Remove and discard the four large slot-head screws from the stove bottom (Fig. 27) and install the stove legs, using the hex head bolts from the parts bag. Use 3/8" washers with three of the legs; the door/damper handle holder installs in place of a washer on the right front leg. Position the holder so the hole to accept the handle nub faces out from the right side of the stove. Tighten the bolts firmly.

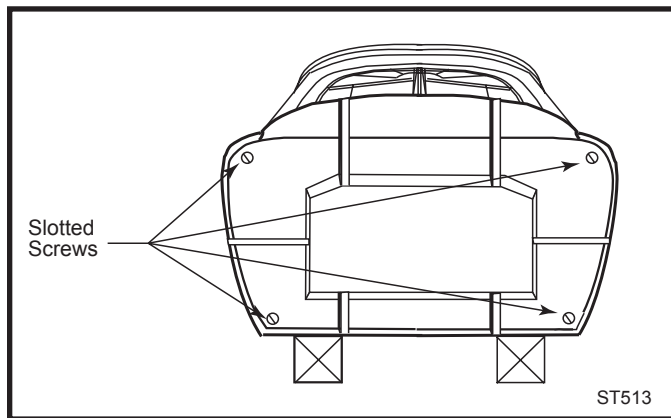


Fig. 27 Remove the slotted screws from the stove bottom.

### Install the Bottom Heat Shield

A bottom heat shield must be used unless the stove is to be situated on a completely noncombustible hearth, such as unpainted concrete over earth. To install the bottom heat shield, loosen the leg bolts, and slip the bottom heat shield C-clips onto the bolts. Attach the bottom heat shield to the C-clips with the wing nuts, and tighten the leg bolts. Align the shield as shown in Figure 28.

### Storing the Handle

Use the removable handle to open or close the front doors, or to change the position of the damper. After using it, remove it so it won't get hot, and store it in the handle holder installed behind the right front leg. (Fig. 29)

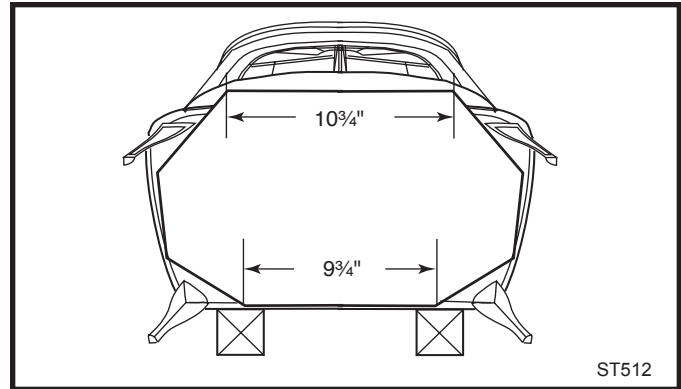


Fig. 28 Attach bottom heat shield.

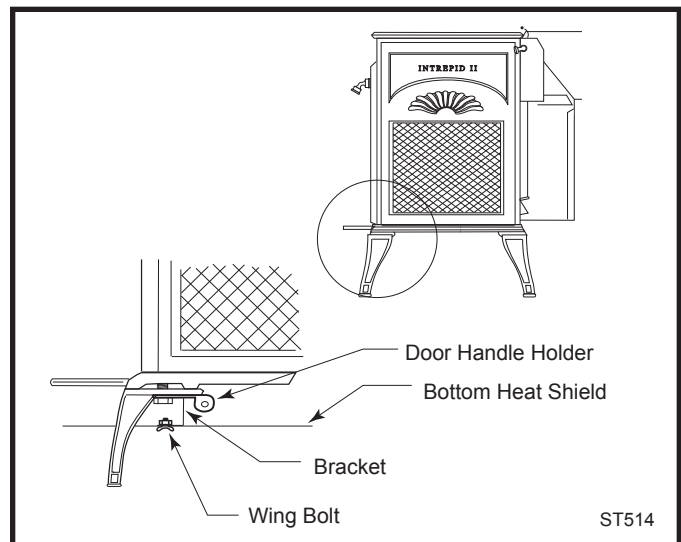


Fig. 29 Handle holder and heat shield positions.

### Reversing the Flue Collar

You can reverse the flue collar by removing the two screws that attach the collar to the back of the stove. (Fig. 30) Be sure the gasket around the flue collar opening is in position when you screw the collar back on to the stove.

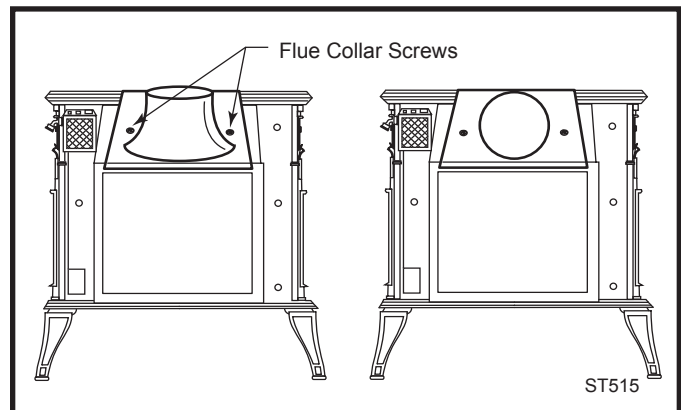


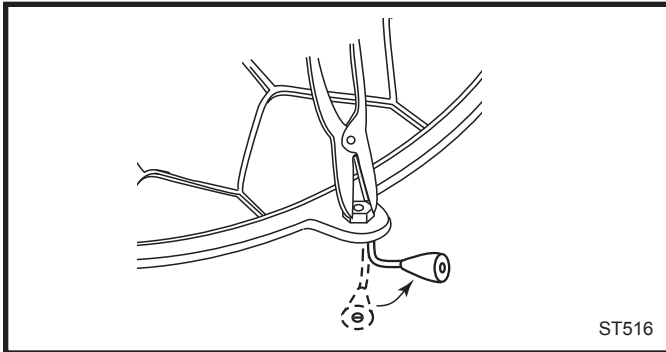
Fig. 30 Reversing the flue collar.



## Attach the Griddle Handle

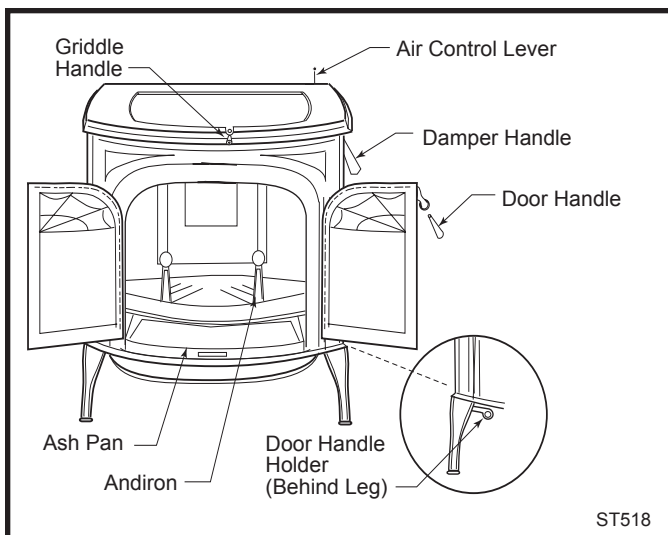
Install the handle on the griddle. Place the griddle upside down at the edge of a flat surface and assemble the handle as shown. (Fig. 31)

With the handle pointing 45° from its final position, tighten the nut as far as possible with pliers. Move the handle to its final position while still holding the nut with the pliers. Take care not to overtighten, as tab may snap.



ST516

Fig. 31 Attaching the griddle handle.



ST518

Fig. 32 The Intrepid II controls.

## Operation

### Your Stove's Controls and What They Do

The stove has two controls to regulate performance: a **primary air control** supplies oxygen for the fire, and a **damper** directs air flow within the stove to activate and deactivate the catalytic combustor.

Additional air for catalytic combustion is regulated automatically, and does not require operator control.

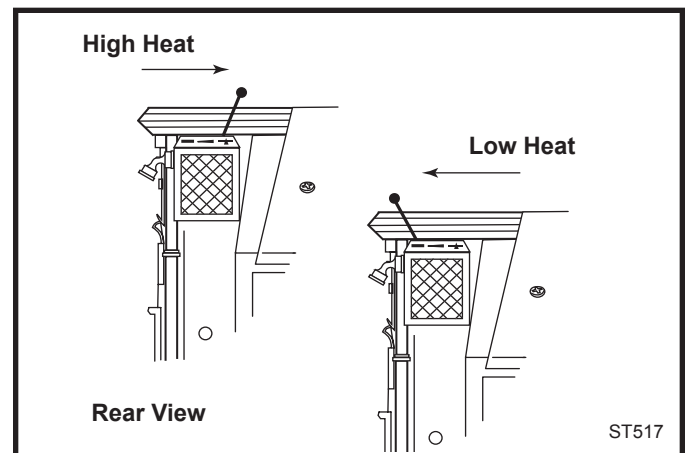
Symbols cast into the stove are reminders of the correct directions for opening and closing the controls. In these directions, 'left' and 'right' assume that you are facing the front of the stove.

## A Single Air Control Regulates the Amount of Heat the Fire Will Produce and How Long it Will Burn

The **primary air control lever**, located at the right rear corner of the stove, controls the amount of incoming air for starting, maintaining, and reviving a fire. More air entering the stove makes the fire burn hotter and faster, while less air prolongs the burn at a lower heat level.

For the greatest air supply and maximum heat output (but the shortest burn time), move the lever to the left. For a fire that will last longer with less heat, move the lever to the right. You can set the lever anywhere in between the left and right extremes. (Fig. 33)

The Intrepid II features an automatic thermostat to ensure an even heat output at any setting you select. The thermostat senses the heating and cooling of the stove surface and adjusts the air shutter accordingly.



ST517

Fig. 33 The thermostat handle may be positioned anywhere between the two extremes for different heat levels.

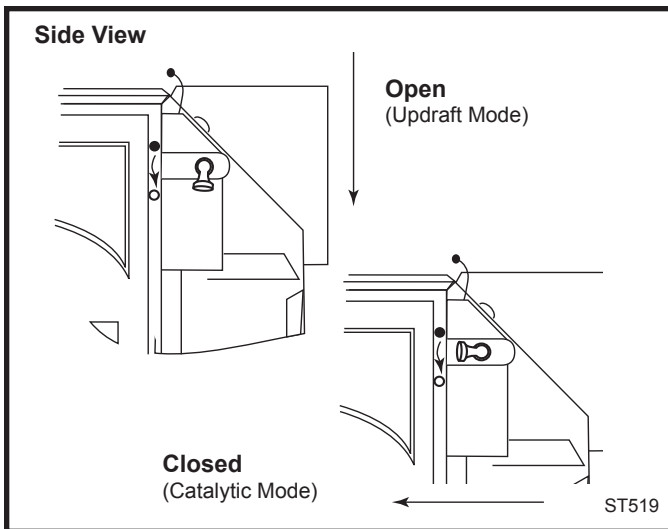
## A Damper Directs Air Flow Within the Stove

The **damper handle** opens and closes the damper to direct air flow within the stove, and is next to, and to the right of, the primary air control lever on the right side of the stove. (Fig. 34)

When the handle points to the floor, the damper is open, letting smoke pass directly into the chimney. The damper **must** be open when starting or reviving a fire, and whenever the griddle or doors are opened.

When the handle points to the front, the damper is closed. Smoke from the fire travels through the catalytic combustion system where it can burn further for greater efficiency, before passing up the chimney.

The damper has no intermediate positions. Figure 28 shows the handle's open and closed positions.



**Fig. 34** The damper is either open or closed. There are no intermediate positions.

**When closing the damper, push firmly and snap it into the locked position to ensure that the stove remains in the catalytic mode.**

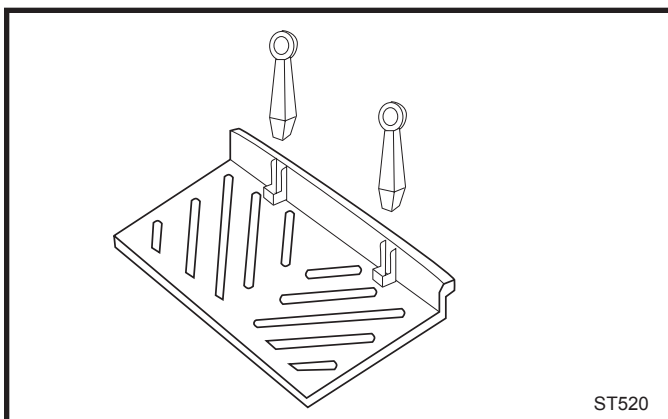
### Glass Door Panels

The glass panels in the doors have a heat-reflective coating on the outside surface. Heat reflected back to the inside of the glass helps keep the inner surface at a higher temperature than the outside. In combination with pre-heated primary combustion air 'washing' over the inside of the glass, this helps provide clear fire-viewing at most operating levels.

### Andirons

Your stove has andirons to keep logs away from the glass panels. The andirons are important to maintain clear fireviewing and should be removed only while reloading through the front doors.

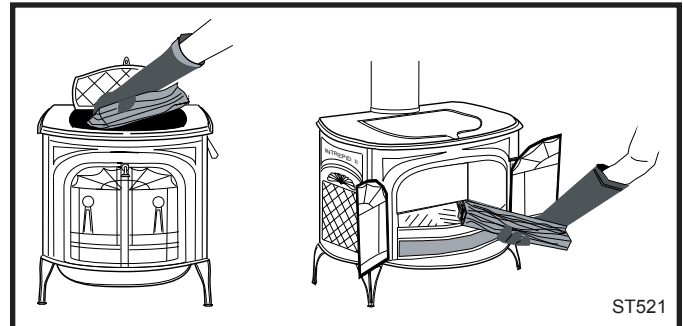
Wear heavy stove gloves when removing the andirons, and place them on a noncombustible surface until you replace them in the stove. Most stove owners will prefer the convenience of top loading through the griddle, and will leave the andirons in place permanently.



**Fig. 35** Remove the andirons for front loading.

### Two Ways to Add Fuel

The Intrepid II's griddle lifts for convenient top-loading of logs, and is the easiest way of regularly adding fuel. However, the front doors open as well for adding an occasional log to a fire. (Fig. 36)



**Fig. 36** Top loading is the best way to add fuel during regular use. Front loading is useful for kindling a fire.

You can open (or even remove) the front doors and place the optional Intrepid II spark screen in the front opening for open-fire viewing.

**WARNING: For safety and greatest efficiency, operate your stove only with all doors/griddles fully closed. The test standard for your stove when it is operated in this mode is UL 1482.**

**Your stove may be used as a fireplace with the front doors open or removed only when the spark screen is placed correctly in the opening to protect against the possibility of sparks and embers leaving your stove. The test standard for your stove when it is operated in this mode is UL 737.**

**Use only the Intrepid II spark screen, part #0136, with your Intrepid II.**

**Intrepid II spark screens are available from your Vermont Castings' Authorized Dealer.**

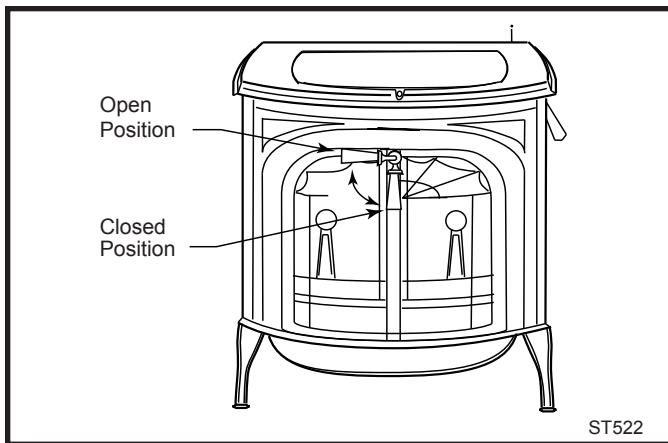
To open the front doors, insert the handle into the door latch stub and turn it to the left and up. To close them, always close the left door first. Turn the handle in the right door to the left and up (to the open position) and close the door. Push on the door as you turn the handle to the right and down. The doors will draw in slightly, and the handle should offer some resistance as you turn it to the closed position. (Fig. 37)

Avoid striking the glass or slamming the doors to reduce the risk of breaking the glass.

When you're not using the door handle, store it in the holder behind the right front leg of the stove.

### Burn Only High-Quality Wood

The Intrepid II is designed to burn natural wood only; do not burn fuels other than that for which it was designed.



**Fig. 37** To open the front doors, turn handle clockwise.

**IMPORTANT: Do not burn any type of artificial or synthetic materials such as fire starter logs (containing wax) in this appliance. Never burn liquid-based fuels such as kerosene, gasoline or alcohol.**

**Burning any materials not allowed in these instructions, or over-firing the stove, may void the warranty.**

You'll enjoy the best results when burning wood that has been adequately air-dried. Avoid burning "green" wood that has not been properly seasoned. The wood should be 16" (410 mm) in length. **Do not burn construction materials;** they often contain chemicals and metals that can damage the catalytic combustor or pollute the air. Do not burn ocean driftwood; when it burns, the salt it absorbs will attack the cast iron.

The best hardwood fuels include oak, maple, beech, ash, and hickory that has been split, stacked, and air-dried outside under cover for at least one year.

For areas that do not have a supply of hardwood, commonly burned softwoods include tamarack, yellow pine, white pine, Eastern red cedar, fir, and redwood. These too should be properly dried.

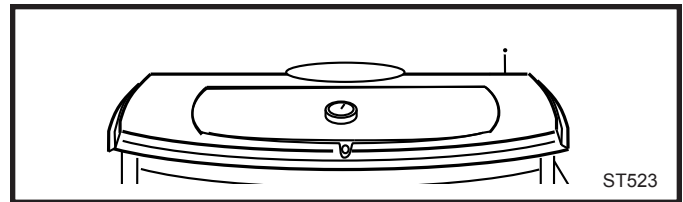
Store firewood under cover to keep it dry. Dry, well-seasoned wood is best for heating and fire-viewing. However, avoid wood dried more than two years. This wood burns very quickly, reducing burn time.

Even for short-term storage, keep wood a safe distance from the heater and keep it out of the areas around the heater used for refueling and ash removal.

### A Surface Thermometer is a Valuable Guide to Operation

An optional surface thermometer tells you when to adjust the air control, when to refuel, and helps to tell when your catalyst is operating properly.

For example, when the thermometer registers at least 450°F (230°C) after start-up you know the stove is hot enough to begin catalytic combustion and it may be time to close the damper.



**Fig. 38** Take temperature readings with a thermometer located in the middle of the griddle.

Place the thermometer in the center of the griddle, as in Figure 38, and use the following temperature ranges as a guide to operation:

When thermometer readings drop below 350°F (175°C) it's time to adjust the air control for a higher burn rate or to reload the stove.

- A temperature reading over 750°F (400°C) is a sign to cut back on the air supply to slow the burn rate.
- Readings in the 300-400°F (150-200°C) range indicate low to medium heat output.
- Readings of 500-650°F (260-340°C) indicate high heat output. Operating your Intrepid II continuously at griddle temperatures of 750°F (400°C) or higher may damage inner parts or the enamel finish.

### Use the Air Control Settings that Work Best for You

No single air control setting will fit every situation. Settings will differ depending on the quality of the fuel, the amount of heat desired, and how long you wish the fire to burn.

The control setting also depends on your particular installation's "draft," or the force that moves air from the stove up through the chimney. Draft is affected by such things as the length, type, and location of the chimney, local geography, nearby obstructions, and other factors.

Too much draft may cause excessive temperatures in the Intrepid II, and could even damage the combustor. On the other hand, too little draft can cause backpuffing into the room and/or the "plugging" of the chimney or combustor.

How do you know if your draft is excessively high or low? Symptoms of too much draft include an uncontrollable burn or a glowing-red stove part. A sign of inadequate draft is smoke leaking into the room through the stove or chimney connector joints, low heat, and dirty glass.

In some newer homes that are well-insulated and weather-tight, poor draft may result from insufficient air in the house. In such instances, an open window near the stove on the windward side of the house will provide the fresh air needed.

Another option for getting more combustion air to the stove is to duct air directly from outdoors to the stove. In fact, in some areas provisions for outside combustion air are required in all new construction.

Your Intrepid II will accept a duct carrying outside air for combustion.

When first using the stove, keep track of the air control settings. You will quickly find that a specific setting will give you a fixed amount of heat. It may take some time to determine the amount of heat and the length of burn you should expect from various settings. Please read the Draft Management section beginning on Page 24 for more information on how installation features affect draft.

Most installations do not require a large amount of combustion air, especially if adequate draft is available.

**Do not for any reason attempt to increase the firing of your heater by altering the air control adjustment range outlined in these directions.**

Use the following air control settings as a starting point to help determine the best settings for your installation. Each is described as a fraction of the total distance the lever may be moved from right to left.

#### Intrepid II Control Settings

Burn Rate	Primary Air Control
Low	From far right to 1/3 the distance to left
Medium	From 1/3 to 2/3 the distance to left
High	From 2/3 the distance to left to far left

Before you start using the stove, please read the Draft Management section starting on Page 24 to see how the features of your installation will affect the stove's performance. You and the stove are parts of a system, and other parts of the system have a strong effect on operation; you may need to vary your firing technique to get the performance you want.

### How to Build a Wood Fire and Keep it Going

An Intrepid II leaves the factory with the combustor installed.

In the United States, it is against the law to operate this wood heater in a manner inconsistent with operating instructions in this manual, or if the catalytic combustor is deactivated or removed.

### High-Efficiency Wood Burning with Catalytic Combustion

The catalytic combustion system in your Intrepid II produces the best conditions for secondary combustion.

When the stove damper is closed, smoke goes through the **catalytic element**, burning at temperatures of 500-600°F (260-315°C), half the temperature normally needed for unaided secondary combustion.

The catalytic element is a ceramic "honeycomb" coated with a noble metal, usually platinum. The element is in the **secondary combustion chamber**, made of a special **high-temperature insulating refractory** material. The chamber provides the correct environment necessary for secondary combustion of the fuel (smoke).

Closing the damper may also reduce draft. Closing the damper too soon may put out the fire or deactivate the combustor. Close the damper only when the fire is well established. When starting a fire, wait until there is an ember bed of at least 3-4" (76-102 mm) before closing the damper.

Never kindle a fire with colored paper or paper that has colored ink or a glossy surface, and never burn treated wood, garbage, solvents, or trash. All of these may poison the catalyst and prevent it from operating properly. Never burn cardboard or loose paper except for kindling purposes. Never burn coal; doing so can produce soot or large flakes of char or fly ash that can coat the combustor and cause smoke to spill into the room. Coal smoke also can poison the catalyst so that it won't operate properly.

In general, the fire must be sufficiently well-established to ensure catalytic activity is initiated. When first starting a fire, maintain a medium- to high- firing rate for at least twenty minutes. This ensures the stove, catalyst, and fuel are all stabilized at the proper operating temperatures. This may be long enough to warm the chimney well enough to support a good draft; some installations may need more time. Please read the Draft Management information starting on Page 24 to see if your installation has features that may require more time to warm up.

Even though it is possible for the fire to get quite hot within a few minutes, the combustor may stop working or the fire may go out if the fire is allowed to die down immediately as a result of closing the damper. Once the combustor starts working, heat generated by burning the smoke will keep it working.

To determine whether the combustor is operating, observe the amount of smoke leaving the chimney when the damper is activated and when it is not. This procedure is described on Page 26.

### Conditioning Your Stove

Cast iron is extremely strong, but it can be broken with a sharp blow from a hammer or from the thermal shock of rapid and extreme temperature change.

The cast plates expand and contract with changes in temperature. When you first begin using your Intrepid II, minimize thermal stress by allowing the plates to adjust gradually during three or four initial break-in fires following **Steps 1-3** below.



## Starting and Maintaining a Wood Fire

Burn solid wood fuel only in the Intrepid II, and burn it directly on the grate. Do not elevate the fuel. Do not burn coal or other fuels.

**The damper must be open when starting a fire or when refueling.**

1. Open the stove damper, and open the primary air control fully.
2. Place several sheets of crumpled newspaper in the stove. Do NOT use glossy advertisements or colored paper, as they can poison the catalyst. Place on the paper six or eight pieces of dry kindling split to a finger-width size, and on the kindling lay two or three larger sticks of split dry wood approximately 1-2" (25-50 mm) in diameter. (Fig. 39)

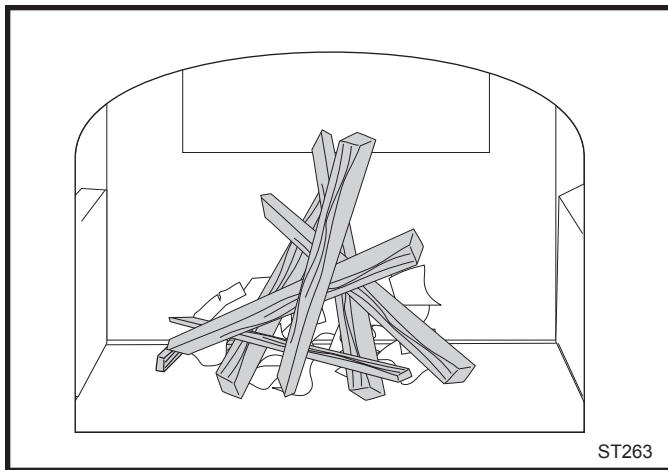


Fig. 39 Start the fire with newspaper and dry kindling.

**DO NOT USE CHEMICALS OR FLUIDS TO START THE FIRE. DO NOT BURN GARBAGE OR FLAMMABLE FLUIDS SUCH AS GASOLINE, NAPHTHA, OR ENGINE OIL. Also, never use gasoline-type lantern fuel, kerosene, charcoal lighter fluid, or similar liquids to start or "freshen up" a fire. Keep all such liquids well away from the Intrepid II while it is in use.**

3. Light the newspaper and close the door. Gradually build up the fire by adding a few 3-5" (76-127 mm) diameter splits. **If this is one of the first few "break-in" fires, let the fire burn brightly, and then let it die out.**

During the break-in fires, don't let the stove get hotter than 500°F (260°C) as measured on an optional stove-top thermometer. Adjust the air control lever as necessary to control the fire. Some odor from the stove's hot metal, the paint, and the cement is normal for the first few fires.

**NOTE:** Some chimneys need to be "primed," or warmed up, before they will draw sufficiently to start a fire. To correct this situation, roll up a couple pieces of newspaper, place them on top of the kindling and toward the back of the stove, light them, and close the doors. This should heat the chimney enough to initiate a draft.

Once the draft is established, open the front door and light the rest of the fuel from the bottom. Do not light the main bed of fuel until the chimney begins drawing, and repeat the procedure as often as necessary if the initial attempt is unsuccessful.

4. If your Intrepid II has been broken-in previously using Steps 1-3, continue to build the fire gradually. Add larger wood with a diameter of 3-4" (76-102 mm). (Fig. 40)

Continue adding split logs of this size to the briskly-burning fire until there is a glowing ember bed at least 3" (75 mm) deep. A good ember bed is necessary for proper functioning of the catalytic system and may take an hour or more to establish.

5. Close the damper when the griddle temperature reaches 450° F (230° C).
6. Adjust the air control for your desired heat output.

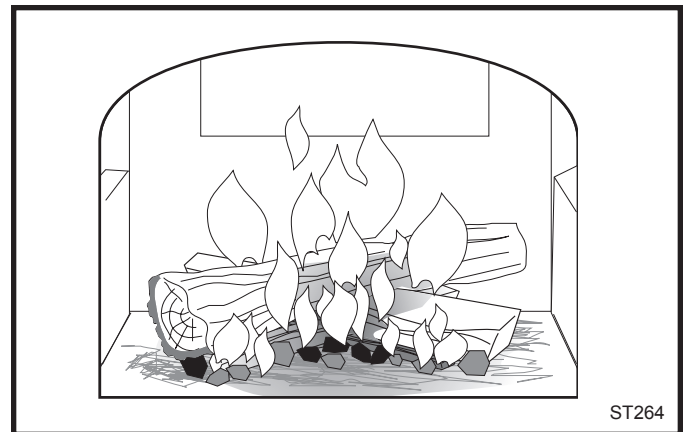


Fig. 40 Add larger pieces of wood as the fire begins to burn well.

## Refuel While the Embers are Still Hot

Reload the Intrepid II while it is still hot and there are plenty of glowing embers to re-kindle the fire. Include some smaller pieces of wood in the new load of fuel to help the stove rebuild its operating temperature quickly.

Wear stove gloves, and follow this procedure when you reload your stove:

1. Open the thermostat lever.
2. Open the damper.
3. Check the ash level in the ash pan; empty, if necessary, and replace the pan.
4. Open the griddle.
5. Position the charcoal in the middle of the firebox (Fig. 41) then load wood — smaller, split pieces first. Increase the amount of fuel you load into the stove as you become familiar with your stove and the heating needs of your home.

**NOTE:** If the remaining charcoal bed is relatively thick and if your fuel is well seasoned, it is possible to add fresh fuel (smaller pieces first), close the door and damper, and reset the primary air thermostat for the desired heat output.



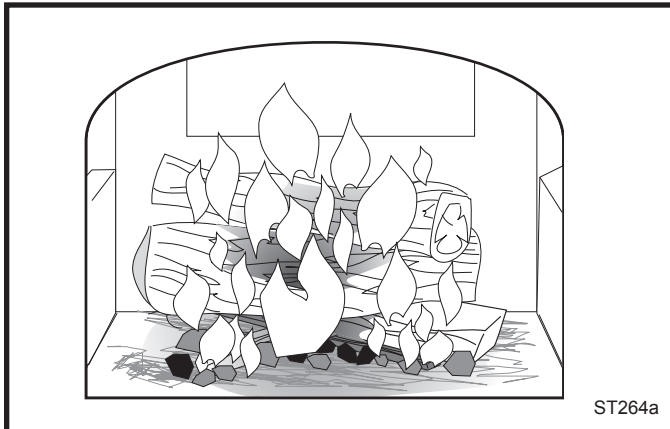
Do not break the charcoal into very small pieces or pound or compress the charcoal bed.

It is important that air can circulate under the wood for the fire to be quickly revived.

**WARNING: Operate your Intrepid II only with the doors either fully open or fully closed.**

**CAUTION: The Intrepid II will be hot while in operation. Keep children, clothing and furniture away. Contact may cause skin burns.**

**DO NOT OVERFIRE THIS HEATER.** Overfiring may cause a house fire, or can result in permanent damage to the stove and to the catalytic combustor. If any part of the Intrepid II glows, you are overfiring.



**Fig. 41** Add full size logs when the ember bed is 3" (75mm) deep.

### Ash Disposal

Remove ash before it reaches the top of the ash pan. Check the level at least once a day, and before each re-fueling. If the ash is close to the top edge of the pan, empty it according to this procedure:

1. Open the damper.
2. Open the front doors fully.
3. Using stove gloves, pull the ash pan out of the stove by its handle.
4. Remove the ash pan and properly dispose of the ashes. Be sure to keep the pan level during disposal.
5. Return the ash pan to the stove.

Empty the ash pan regularly, typically every one to three days. The frequency will vary depending on how you operate your Intrepid II; if you burn more wood at higher heat output settings, ash will accumulate rapidly.

Remove ash frequently and place it outdoors in a metal container with a tight-fitting lid. Put the closed container of ash on a noncombustible floor or on the ground, well away from all combustible materials, pending final disposal. If the ash is disposed of by burial in soil or otherwise locally dispersed, keep it in the closed container until all cinders have thoroughly cooled. You can use wood ash as a garden fertilizer.

**CAUTION:** Never use your household or shop vacuum cleaner to remove ash from the stove; always remove and dispose of the ash properly.

### Draft Management

A stove is part of a system, which includes the chimney, the operator, the fuel, and the home. The other parts of the system will affect how well the stove works. When there is a good match between all the parts, the system works well.

Wood stove operation depends on natural (unforced) draft. Natural draft occurs when the smoke is hotter (and therefore lighter) than the outdoor air at the top of the chimney. The bigger the temperature difference, the stronger the draft. As the smoke rises from the chimney it provides suction or 'draw' that pulls air into the stove for combustion. A slow, lazy fire with the stove's air inlet fully open indicates a weak draft. A brisk fire, supported only by air entering the stove through the normal inlet, indicates a good draft. The stove's air inlet is passive; it regulates how much air can enter the stove, but it doesn't move air into it.

Depending on the features of your installation - steel or masonry chimney, inside or outside the house, matched to the stove's outlet or oversized - your system may warm up quickly, or it may take a while to warm up and operate well. With an 'airtight' stove, one which restricts the amount of air getting into the firebox, the chimney must keep the smoke warm all the way to the outdoors. Some chimneys do this better than others. Here's a list of features and their effects.

### Masonry Chimney

Masonry is a traditional material for chimneys, but it can perform poorly when it serves an 'airtight' stove. Masonry is a very effective 'heat sink' - it absorbs a lot of heat. It can cool the smoke enough to diminish draft. The bigger the chimney, the longer it takes to warm up. It's often very difficult to warm up an outdoor masonry chimney, especially an oversized one, and keep it warm enough to maintain an adequate draft.

### Steel Chimney

Most factory-made steel chimneys have a layer of insulation around the inner flue. This insulation keeps the smoke warm. The insulation is less dense than masonry, so the inner steel liner warms up more quickly than a masonry chimney. Steel doesn't have the good looks of masonry, but it performs much better.

### Indoor/Outdoor location

Because the chimney must keep the smoke warm, it's best to locate it inside the house. This uses the house as insulation for the flue and allows a little heat release into the home. An indoor chimney won't lose its heat to the outdoors, so it takes less heat from the stove to get it warm and keep it warm.

## Flue sizing

The inside size of a chimney for an 'airtight' stove should match the size of the stove's flue outlet. When a chimney serves an airtight, more is not better; in fact, it can be a disadvantage. Hot gases cool off through expansion; if we vent a stove with a six-inch flue collar (28 square inch area) into a 10 x 10" flue, the gases expand to over three times their original size. This cools the gases, which weakens draft strength. If an oversized flue is also outside the house, the heat it absorbs gets transferred to the outdoor air and the flue usually stays cool.

It's common for a masonry flue, especially one built for a fireplace, to be oversized for an airtight stove. It can take quite a while to warm up such a flue, and the results can be disappointing. The best solution to an oversized flue is an insulated steel chimney liner, the same diameter as the stove or insert's flue outlet; the liner keeps the smoke at its original volume, and the result is a stronger draft. An uninsulated liner is a second choice - the liner keeps the smoke restricted to its original size, but the smoke still must warm up the air around the liner. This makes the warm-up process take longer.

## Pipe & Chimney Layout

Every turn the smoke must take in its travel from the stove to the chimney top will slow it down. The ideal pipe and chimney layout is straight up from the stove, to a completely straight chimney. If you're starting from scratch, use this layout if possible. If the stovepipe must elbow to enter a chimney, locate the thimble about midway between the stove top and the ceiling. This achieves several goals: it lets the smoke speed up before it must turn, it leaves some pipe in the room for heat transfer, and it gives you long-term flexibility for installing a taller stove without relocating the thimble.

There should be no more than eight feet of single-wall stove pipe between the stove and a chimney; longer runs can cool the smoke enough to cause draft and creosote problems. Use double-wall stove pipe for long runs.

## Single Venting

Each 'airtight' stove requires its own flue. If an airtight stove is vented to a flue that also serves an open fireplace, or a leakier stove, it's easier for the chimney draft to pull air in through those channels than it is to pull air through the airtight, and performance suffers. Imagine a vacuum cleaner with a hole in the hose to see the effect here. In some cases the other appliance can even cause a negative draft through the airtight, and result in a dangerous draft reversal.

## Creosote

Creosote is a by-product of slow wood-burning. It's an organic tar that can condense in the flue if it's dense in the smoke, and slow-moving, and cools off to less than

290°F. Condensed creosote is volatile, and can generate chimney fires if it gets hot enough. All the features that affect chimney draft also affect creosote condensation - so use whatever combination of installation features and operational steps will encourage good draft and minimize creosote production.

Because letting the smoke cool off and slow down is one of the keys to creosote production, it makes sense to line a chimney to match the stove's outlet size, for safety reasons as well as performance. Canadian law requires a matching liner to serve any stove or insert vented through a fireplace chimney; in the US, the National Fire Protection Association recommends one if the flue is more than three times bigger (in square area) than the outlet on the stove or insert. Some localities enforce the NFPA guidelines as part of their building codes.

## Fuel

Even the best stove installation will not perform well with poor fuel. The best fuel is hardwood that has air-dried 12-18 months. Softwood burns, but not as long as hardwood. Fairly 'green' wood has a good amount of moisture in it; it will burn, but some of the heat potential is used to drive the remaining moisture off the wood. This reduces the amount that reaches your home and can contribute to a creosote problem. There are moisture meters available for firewood; you can also judge your wood by its appearance and weight. If you get it green, lift a piece and get a sense of its weight; it can lose a third or more of its weight as it dries. Also look at the ends of a log; as it dries it shrinks and often cracks. The more weathered and cracked a piece is, the drier it is.

Dry wood burns readily with a good chimney draft. But with modern stoves, especially catalytic ones, the wood can be too dry. While extra-dry wood has little creosote in it, the remainder can 'gas out' from the wood quickly and densely enough to overload the catalytic burner. If you hear a rumbling or roaring noise, like a propane torch, from the stove, that is a sign that the catalyst is seriously overfiring. The catalyst is a platinum film on a ceramic base; the metal can get to higher temperatures than the ceramic can take, and overfiring the catalyst can break it. Dry wood can also burn out faster than you want. If your dry wood burns out too quickly or overloads the catalyst you can mix in greener wood to slow the fire down.

## Back-puffing

Back-puffing results when the fire produces volatile gases faster than the chimney draft pulls them out of the firebox. The gases back up in the firebox till they're dense enough and hot enough to ignite. If your stove back-puffs, you should open up the damper to let the smoke rise to the flue more quickly, let more air into the firebox, and avoid big loads of firewood. Run your stove with enough primary air so that you always see lively, dancing flames in the

firebox; a lazy, smoky fire is inefficient and can contribute to creosote buildup in the chimney.

### **Draft Testing**

An easy way to test your chimney draft is to close the stove's damper, wait a few minutes to let the airflow stabilize, then see whether you can vary the strength of the fire by swinging the air control open and closed. Results are not always instant; you may need to wait a few minutes for a change in the air control setting to have an effect on the fire. If there's no change, then the draft isn't strong enough yet to let you close the damper, and you'll need to open it for a while longer and manage the fire with the air inlet until the draft strengthens. If you keep track of your burning habits and relate them to their effects on the stove's operation, you'll be rewarded with good performance and a safe system.

### **Negative Pressure**

Good draft also depends on a supply of air to the stove; a chimney can't pull in more air than is available to it. Sluggish draft results when a house is tight enough to prevent the ready flow of air to the stove, or by competition between the stove and other equipment that sends indoor air outside - especially power-driven equipment like range hoods, clothes dryers, etc. If the chimney draws well with all other equipment turned off (or sealed, in the case of fireplaces and/or other stoves), then you simply need to be careful with timing the use of the other equipment. If you need to crack a nearby window or door to enable the chimney to draw well, that's a sign that you should install an outside-air intake to bring combustion air directly to the stove. Vermont Castings dealers carry adapters to attach to the stove to connect an air duct for outdoor combustion air.

### **Conclusion**

Wood-burning is an art rather than a science. Once the stove and chimney system are in place, the stove user can only vary technique, mostly your timing, to achieve good results. If you keep track of your burning habits and relate them to their effects on the stove's operation, you'll be rewarded with good performance and a safe system.

## **Maintenance**

Let the fire in the stove go out and allow the stove to cool completely before beginning any maintenance procedure.

### **Care of the Cast Iron Surface**

An occasional dusting with a dry rag will keep the painted cast iron of your Intrepid looking new.

The stove's paint can be touched up as needed. First, clean the areas to be painted with a wire brush. Then, touch up the stove with high temperature stove paint. Apply the paint sparingly, and keep in mind that two light coats of paint are better than a single heavy one.

### **Care of Porcelain Enamel Finish**

Use a dry or slightly damp rag or a soft brush to remove spills or stains. For difficult jobs that require a cleaning agent, use only a kitchen appliance cleaner or polish recommended for use on enamel surfaces.

### **Cleaning the Glass**

Most of the carbon deposits on the glass will burn off during hot fires. However, the ash residue that accumulates on the glass surface should be removed regularly to prevent etching. Follow this procedure to clean the glass:

- Be sure the glass is completely cool.
- Clean the glass with water or a cleaner made especially for this purpose. Do not use abrasive cleaners.
- Rinse the glass thoroughly.
- Dry the glass completely.

### **Glass Replacement**

Replace glass only with Part no. 140-1156 right side and 140-1157 left side glass panels. The glass panel rests on a cushion provided by a rope gasket part no 1203556, and is held in place by clips. (Fig. 42) The glass is IR coated on one side which is marked "THIS SIDE OUT".

1. Remove the door from the stove and place it on a sturdy, level work surface. Use a towel to protect the porcelain enamel finish.
2. Remove the retainer clips. (Two phillips head screws on each clip.)
3. Inspect the gasket. If the window gasket is in good condition, you can leave it in place. If you replace it, use only Part No. 1203556. Be sure the channel around the window opening is clean, and free of dust.
4. Install the glass. Lay the glass on the inner gasket with the coated side down (toward the outside of the door). Tighten the screws snugly, but loose enough to allow for a little movement of the glass when the stove is in operation. Overtightening can crack the glass immediately or cause it to crack if it is unable to expand when hot.

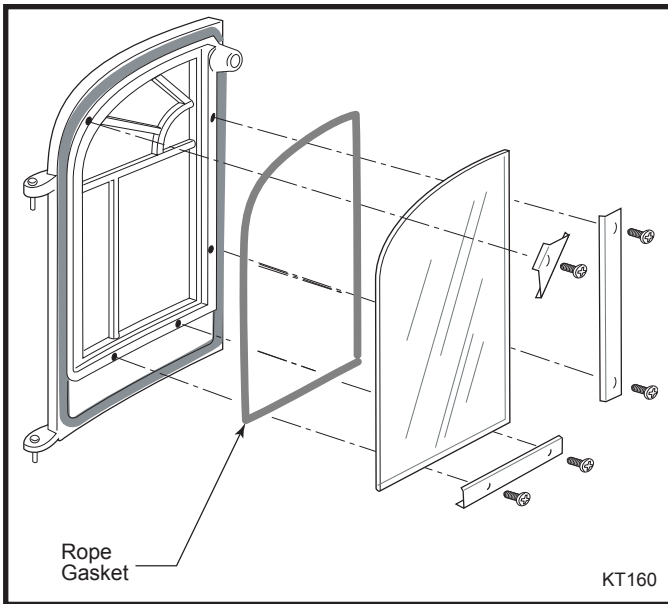


Fig. 42 Door glass installation.

### Check the Operation of the Primary Air Shutter

The primary air shutter is visible from the back of the stove. The shutter must open and close freely when you move the thermostat lever. If it does not, check for any obstruction, or for a bound or stretched chain needing adjustment. (Fig. 43)

On a cold stove the shutter should be open no more than 1/8" (3 mm) when the primary air control lever is pushed completely to the left (closed), as seen from the back of the stove. When the lever is pushed completely to the right (open), the shutter should be open to an angle of approximately 70° from the stove back.

The ball chain should measure 8½" (216 mm) from connection to the thermostat coil to connection on the primary air flap.

If setting is incorrect, the thermostat coil may be bent or broken. Call your Vermont Castings Dealer for assistance.

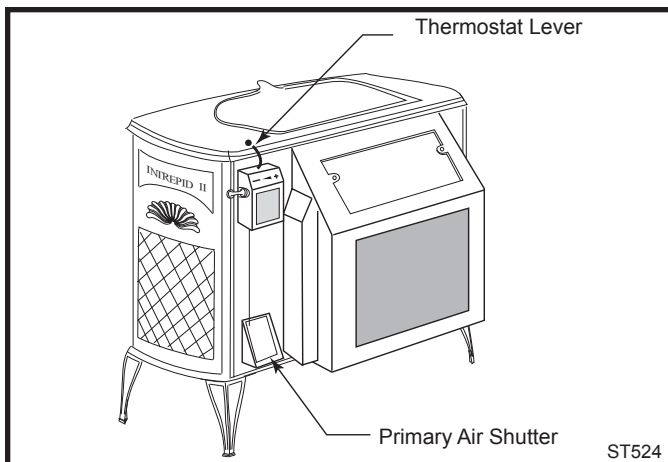


Fig. 43 The primary air shutter must move freely.

### How to Adjust the Door Latch

Over time, the gasketing around the doors will compress, and the latch may need adjustment. To adjust the latch, loosen the small locking nut, extend the striker screw one turn while keeping the striker screw from turning. (Fig. 44) Keep making adjustments a little at a time until the setting is right.

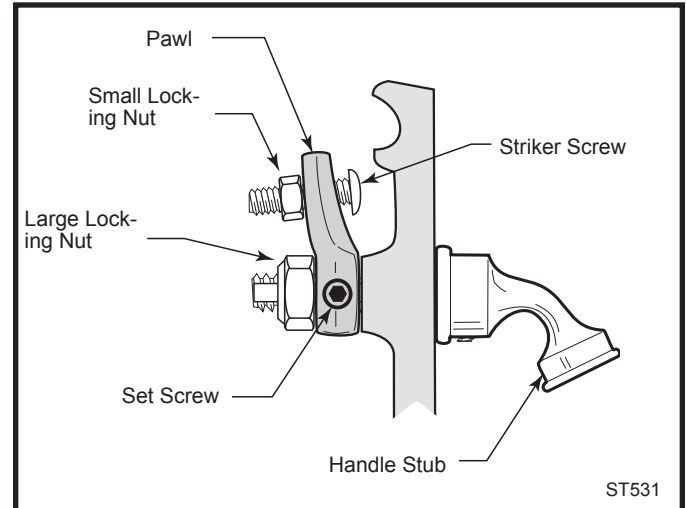


Fig. 44 Turn the door latch striker screw in or out to tighten or loosen the door latch.

The front doors of the stove should close securely and tightly, when the handle is in the closed position. When the latch is properly adjusted there should be a slight resistance as the doors are moved to the completely closed position.

### Tighten the Damper Handle as Needed

The damper handle is attached to the damper rod with a set screw bearing against a flat spot on the rod. Check the set screw periodically for tightness; tighten as needed.

### Damper Adjustment

When the stove damper is closed, the pressure of the rod against the damper plate assures a good seal between the damper and the damper housing. Adjustment may be needed after a period of time to retain adequate pressure.

To make this adjustment, start with the damper in the closed and locked position. (Fig. 45) Loosen the 7/16" locking nut in the center of the damper. Use a 1/8" Allen wrench to turn the Allen screw a full turn clockwise. Test the damper for snugness, and continue adjusting the Allen screw as needed. Tighten the 7/16" locking nut when the damper operates smoothly but firmly.



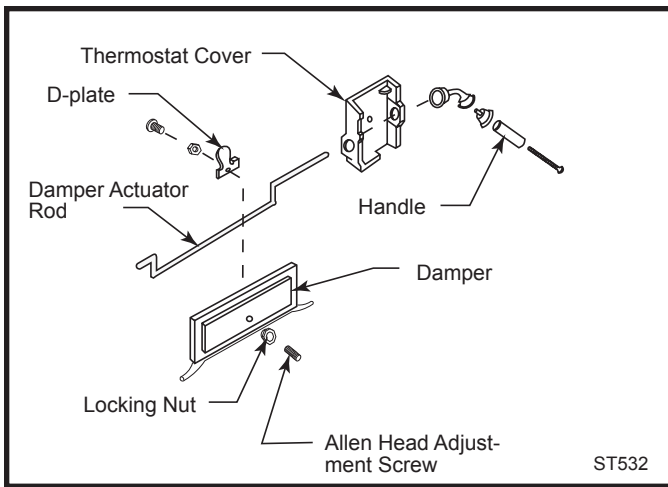


Fig. 45 Tighten the damper adjustment screw for a snug seal.

## The Catalytic Combustion System Inspection and Cleaning

This wood heater includes a catalytic combustor, which needs periodic inspection and replacement for proper operation. In the United States, it is against the law to operate this wood heater in a manner inconsistent with the operating instructions in this manual, or if the catalytic element is deactivated or removed.

Under normal operating conditions the catalytic element should remain active for two to six years (depending on the amount of wood burned). However, it is important to monitor the combustor periodically to ensure that it is functioning properly as well as to determine when it needs to be replaced.

A probe thermostat, passing through the back of the stove into the catalytic combustion chamber, automatically regulates the catalytic combustion air supply. Deterioration of the probe may result in decreased catalytic combustor performance.

A poorly-functioning catalytic combustion system will result in a loss of heating efficiency, and an increase in creosote and emissions.

The combustor should be visually inspected in place for fly ash accumulation and physical damage three times per year. Do not remove the combustor unless a more detailed inspection is warranted because of diminished performance as outlined below, or to inspect the probe thermostat.

The refractory package that houses the catalytic combustor should be inspected annually for a buildup of flay ash, and cleaned if necessary. This may be done during examination of the combustor.

The probe thermostat should be inspected annually, or more often if decreased catalytic combustion performance is not due to a defective combustor.

## When to Suspect a Combustion System Problem

The best way to evaluate the performance of your Intrepid II's combustion system is to watch the amount of smoke leaving the chimney - both when the combustor has achieved "light-off" and when it has not. Follow this procedure:

With a fire going and the combustor activated, with the damper closed to send smoke through the combustor as described in the Operation Section, go outside and watch the smoke leaving the chimney.

Then, open the stove damper and again watch the smoke leaving the chimney.

You should see significantly more smoke after the second step, when the stove damper is open and smoke does not go through the combustor. However, do not confuse smoke with steam from wet wood; steam disappears rapidly in the air, smoke does not.

If this test indicates a problem, consider other possible factors as well, such as the time of year or a change in the quality of your fuel. In spring and fall, draft is weaker than it is during colder winter weather, and fires can burn sluggishly. Small, hot fires are a good solution under these conditions.

"Green" (insufficiently seasoned) wood will burn more poorly than properly seasoned fuel. You may have to run your stove hotter (with more primary air) to achieve good performance if you are burning green or wet wood.

Also, consider any changes in your burning routine.

Once you have ruled out any other possible causes for decline in performance, you may inspect the combustor and probe. Wear a dust mask, safety glasses, and gloves. Refer to Figure 46 as a guide.

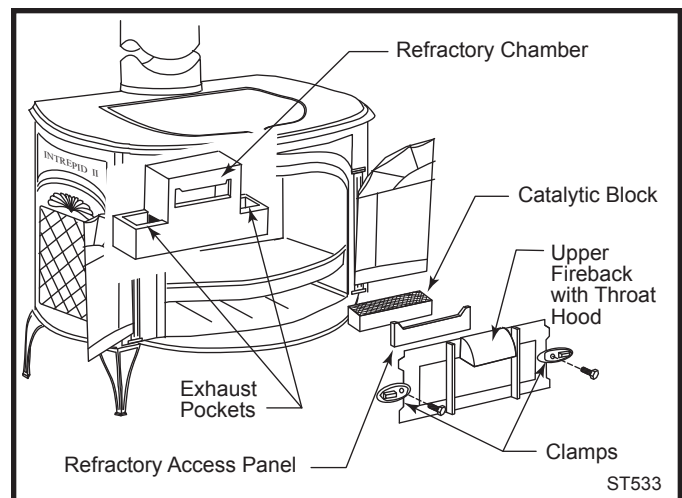


Fig. 46 Removing the catalytic element.



1. Remove the andirons.
2. Reach inside the stove with a pair of pliers and turn the two clamps that hold the fireback 90°. Turn the left clamp clockwise, and the right clamp counterclockwise.
3. Grasp the fireback by its vertical ribs and remove it, together with the attached throat hood. Pull the left side out first.
4. Carefully clean the left and right exhaust pockets of the refractory package. Use a shop vacuum, ideally one with a very fine filter, and be careful to avoid damaging the refractory material. This material can stand high temperatures, but it is somewhat brittle physically.
5. Carefully remove the refractory access panel in front of the catalytic element.
6. Gently slide the catalytic element out of the refractory chamber. Check the element and the bottom of the chamber for a buildup of fly ash.
7. If the catalytic element is clogged, take it outdoors for cleaning. Blow gently through the honeycomb. A large amount of fly ash may come out of the element.
8. Inspect the element. Although small hairline cracks will not affect performance, the element should be largely intact. If the element is broken in pieces or has large sections missing, replace it. Call your dealer for a replacement element.
9. Use a flashlight and a mirror, inserted into one of the exhaust pockets of the refractory chamber, to inspect the probe. The end of the probe should extend about 1" into the combustion chamber, and should not show any signs of deterioration.

Use the stove in your usual manner for two weeks, inspecting the chimney and the chimney connector frequently.

If creosote does not build up as quickly as before, it is likely that the performance change was caused by fly ash deposits on the catalytic element. However, monitor the chimney system for a few weeks to ensure that proper performance continues.

If you continue to find a significant creosote buildup or if you continue to see excessive smoke from the chimney, the catalytic element will need to be replaced. Call your dealer for information about a replacement.

**NOTE:** Use only replacement catalyst supplied by an authorized Vermont Castings dealer.

### Replace Refractory Package

Refer to Figure 46.

1. Remove andirons.
2. Reach inside the stove with pair of pliers and turn the two clamps that hold the fireback 90°. Turn the left clamp clockwise and the right clamp counterclockwise. The

- bolts that hold these clamps are tapped into the back as well as capped by chrome acorn nuts in the back.
3. Grasp the upper fireback by its vertical ribs and remove it, together with the attached throat hood. Pull the left side out first.
4. Carefully remove the refractory access panel in front of the catalytic block.
5. Gently slide the catalytic block out of the refractory chamber.
6. Remove the damper housing. It is held in place by two weld screws and two chrome acorn nuts in the back of the stove. Loosen the chrome acorn nuts and rotate the tabs to release the damper housing. You may find it necessary to remove or loosen the thermostat cover to access the one of acorn nuts installed behind the cover.
7. Remove the rear airtube in the back of the stove which is held in place with two phillips screws.
8. Take out the secondary probe by removing the upper phillips screw and sliding the probe out of the hole.
9. Lift the damaged refractory chamber up and out of the firebox.
10. Reverse the procedure for installing the new refractory chamber.

### Replace the Stove Gaskets as Needed

The Intrepid uses fiberglass rope gaskets to make a tight seal between some parts. With use, particularly on those parts that move, gaskets can become brittle and compressed, and can begin to lose their effectiveness. These will need periodic replacement.

The sizes of replaceable gasket are listed below, along with their applications.

#### Gasket Diameter... And the Parts it Seals

5/16" wire gasket	The griddle to the stove top
5/16"	The damper to the upper fire back; the front doors to the stove front; and the door halves to each other

There is a flat, die-cut gasket between each glass panel and its door. See page 24 for information on replacing the glass panel or its gasket.

If you need to change a gasket, first obtain an appropriate replacement from your Vermont Castings, Dealer.

Wait until the fire is out and the stove has cooled. Be sure to follow the standard safety procedure for working with dusty materials: Wear safety goggles and a dust mask.

The procedure for replacing the gaskets is the same, regardless of the gasket location.

1. Remove the existing gasket by grasping an end and pulling firmly.
2. Use a wire brush or a screwdriver to clean the channel of any remaining cement or bits of gasket. Remove stubborn deposits of cement with a cold chisel if necessary.
3. Determine the correct length of the appropriate-sized gasket by laying it out in the channel. Allow an extra 1-2" (25-50mm) and mark the spot to be cut.
4. Remove the gasket from the channel, place it on a wood cutting surface, and cut it at the marked spot with a utility knife. Twist the ends slightly to keep the gasket from unraveling.
5. Lay an unbroken 1/8" (3mm) bead of gasket cement in the newly-cleaned channel. Starting at one end, press the gasket into the channel. Ensure a good joint where the gasket meets before trimming any excess. Do not overlap the gasket ends or leave ends with ragged edges.
6. Press the gasketed part firmly against its normal mating surface to seat the gasket evenly in its channel.
7. For doors, replace the doors and close them on a piece of waxed paper to keep the cement from migrating onto the stove front, or tap other parts with the rubber mallet (or hammer/block of wood).
8. Clean excess cement from around the channel. Let the cement that holds the new gasket dry thoroughly.

### **Adjust the Door if Necessary**

The door latch or damper mechanism may need adjustment after you have regasketed them. Initially, it may require loosening to accommodate the new gasket; after a few weeks, it may need tightening to compensate for compression of the new gasket. The directions for adjusting the latch and damper are on Page 27.

### **Permanent Gaskets**

Other gaskets seal between non-moving parts, but these are not subject to the same wear and deterioration as gaskets on moving parts. It is unlikely that you will ever need to replace these gaskets unless the involved parts are disassembled and then put back together. If this is the case, the job should be done only by a qualified service technician. The diameter of the gasket that seals these non-moving parts is 5/16", and the areas sealed are the flue collar to the stove back; and the lower fireback to the sides. The glass panels use a special die-cut flat gasket; refer to Page 24 for information on these.

## **The Chimney System**

### **Creosote**

Your Intrepid II is designed to reduce creosote buildup significantly. However, regular chimney inspection and maintenance must still be performed. For safety, good stove performance, and to protect your chimney and chimney connector, inspect the chimney and chimney connector on a regular schedule. Clean the system if necessary. Failure to keep the chimney and connector system clean can result in a serious chimney fire.

When wood is burned slowly, it produces tar, organic vapors and moisture that combine to form creosote. The creosote vapors condense in the relatively cool chimney flue. As a result, creosote residue accumulates on the flue lining. When ignited, this creosote makes an extremely hot fire within the flue system that can damage the chimney and overheat adjacent combustible material.

**If you do have a chimney fire, act promptly to:**

- **Close the damper and thermostat lever.**
- **Get everyone out of the house.**
- **Call the Fire department.**

You should inspect the system every two weeks during the heating season as part of a regular maintenance schedule. To inspect the chimney, let the stove cool completely. Then, using a mirror and a strong light, sight up through the flue collar into the chimney flue. If it is not possible to inspect the flue system in this fashion the stove must be disconnected to provide better viewing access.

If a significant layer of creosote has accumulated - 1/8" (3mm) or more - remove it to reduce the risk of a chimney fire.

Clean the chimney using a brush the same size and shape as the flue liner. Flexible fiberglass rods are used to run the brush up and down the liner, causing any deposits to fall to the bottom of the chimney where they can be removed through the clean out door.

The chimney connector should be cleaned by disconnecting the sections, taking them outside, and removing any deposits with a stiff wire brush. Reinstall the connector sections after cleaning, being sure to secure the individual sections with sheet metal screws.

If you cannot inspect or clean the chimney yourself, contact your local Vermont Castings authorized dealer or hire a professional chimney sweep.

### **Annual Maintenance**

Perform a thorough cleaning, inspection and repair each spring, at the end of the heating season.

- Thoroughly clean the chimney and chimney connector.

- Inspect the chimney for damage and deterioration. Replace weak sections of prefabricated chimney. Have a mason make repairs to a masonry chimney.
- Inspect the chimney connector and replace any damaged sections.
- Check gasketing for wear or compression, and replace if necessary. A 'paper test' will guide you on this. Close and lock the door or damper on a slip of paper and then try to pull the paper out. If the paper pulls out with little or no resistance, the gasket is not snug enough at that spot. If adjusting the damper or latch does not result in a seal that makes it hard to pull the paper out, replace the gasketing.
- Inspect and clean the catalytic block, and vacuum out the ash at the bottom of the back plate after removing the lower fireback. Lightly clean the refractory assembly that houses the element. Be careful not to damage the refractory material, which is very fragile.
- Inspect the secondary probe thermometer; refer to Page 30.
- Check door and damper handles for tightness. Adjust if needed.
- Check heat shield screws. Tighten as necessary.
- Clean dust from the inner sides of bottom, rear and connector heat shields.
- Remove ashes from the ash pan and replace with moisture absorbing material (such as cat litter) to keep the stove interior dry. Close the stove door to keep cats from using the litter.
- Touch up the paint on black stoves.

## Appendix: Catalytic Combustor

In any chemical reaction, including the combustion process, there are certain conditions which must be met before the reaction can take place. For example, a reaction may require a certain temperature, or a certain concentration of the reactants (the combustion gases and oxygen), or a certain amount of time. Catalysts, though not changed themselves during the reaction, have the ability to act at a molecular level to change these requirements. In the Intrepid II's secondary combustion chamber the catalyst reduces the temperature at which secondary combustion can start from the 1000 - 1200°F (540 - 650°C) range to the 500 - 600°F (260 - 315°C) range, increasing efficiency, and reducing creosote and emissions.

The catalytic reaction, though advantageous, does have some limitations of its own. Primary among these it that the reactants (the gases) come into close physical contact with the catalyst itself.

To ensure the necessary contact, the catalytic element in your Intrepid II is composed of a ceramic base in the shape of a honeycomb. On each of the honeycomb's many surfaces a coating of the catalyst (usually a noble metal such as platinum or palladium) is applied. The large surface area exposed in this configuration ensures that the combustion gases have the greatest opportunity to come in contact with the catalyst.

Loss of catalytic activity will be apparent in several ways. First you may notice an increase in fuel consumption. Second, there will be a visible increase in the rate at which creosote builds up in your chimney connector system. You may also notice a heavy discharge of smoke from the chimney. A number of catalytic problems which can cause loss of activity are described below:

### Blockage

While the honeycomb pattern ensures good contact, it also increases the resistance to flow of the combustion gases, and, because of the many surfaces, provides more places for creosote and fly ash to deposit. It is important to follow the operating instructions in order to minimize these deposits, and to periodically inspect your catalyst for signs of blockage.

### Masking and Poisoning

While the catalyst itself does not enter into the combustion process, it is possible for certain elements, such as lead and sulfur, to attach to the active sites on the surface of the honeycomb. Though the catalyst is still there, it is covered, or masked, by the contaminant, and cannot function. To avoid this situation, it is important not to burn anything in your Intrepid II that is a source of these contaminants. Particularly avoid painted or treated wood, coal, household trash, colored papers, metal foils, or plastics. Chemical chimney cleaners may also contain harmful elements. The safest approach is to burn only untreated, natural wood.

### Flame Impingement

The catalytic element is not designed for exposure to direct flame. If you continually overfire your Intrepid II, the chemistry of the catalyst coating may be altered, inhibiting the combustion process. A glowing stove part at the back of the firebox is a sign of over-firing.

Thermal degradation of the ceramic base may also occur, causing the element to disintegrate. Stay within the recommended guidelines of the Operation section.

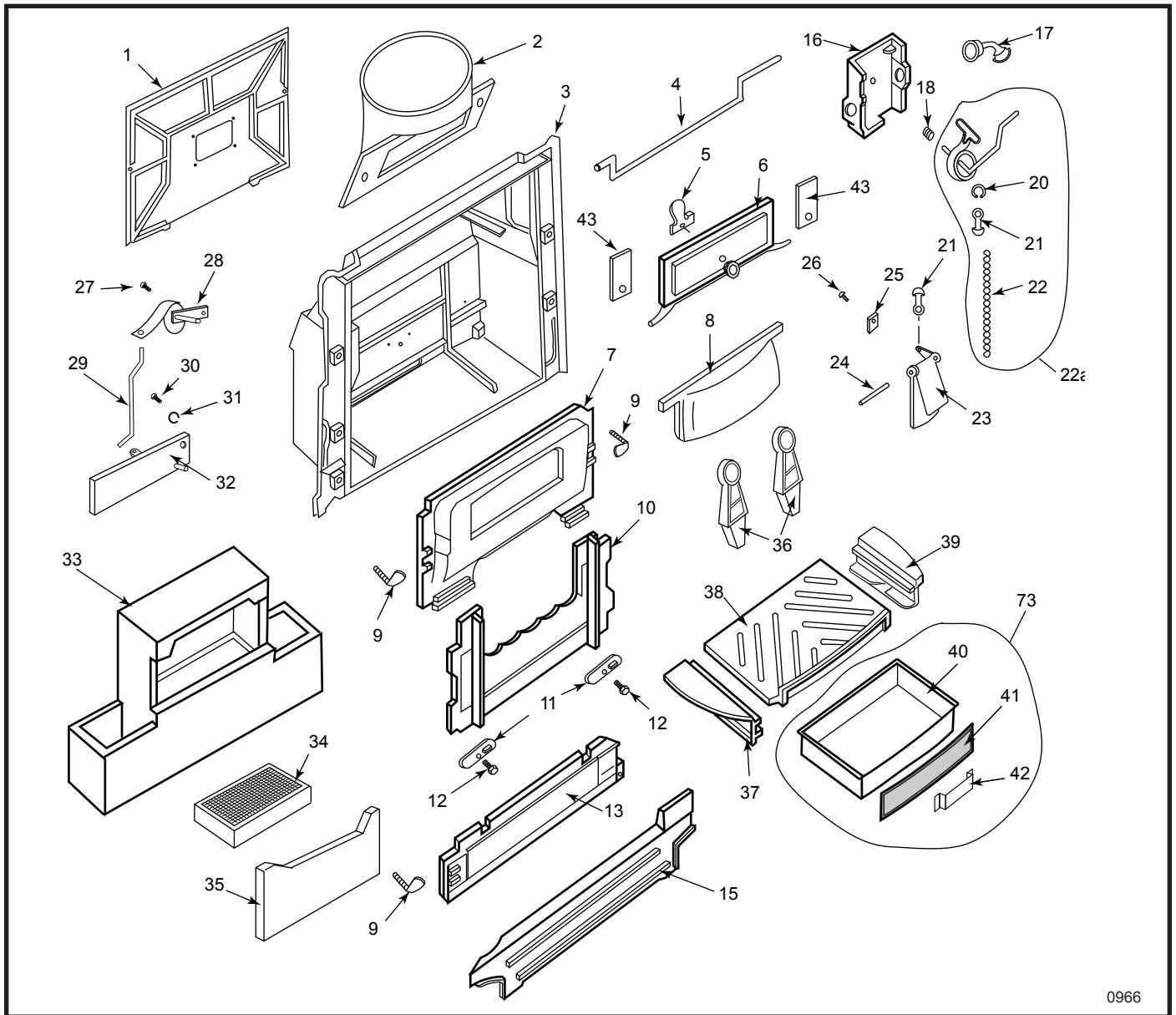
### Mechanical Damage

If the element is mishandled, damage may occur. Always treat the element carefully. Remember the catalyst is made of a ceramic material; treat it as you would fine china. Hairline cracks will not affect the performance of the catalyst, as long as the steel sleeve holds the element in the proper position.

### Peeling

Peeling of the surface coat may occur if the catalytic element is frequently subjected to excessive temperatures. Follow the operating instructions carefully to avoid this type of damage.

Every Vermont Castings Group product is equipped with either a Corning "Long-Life"® or a Technical Glass Products "Honeycomb"®. The products are equivalent. If for any reason you must ship your catalytic element, remember its fragile nature. Place the element in a plastic bag, and package it with a generous amount of shock absorbing material.



0966

Vermont Castings Group reserves the right to make changes in design, materials, specifications, prices and discontinue colors and products at any time, without notice.

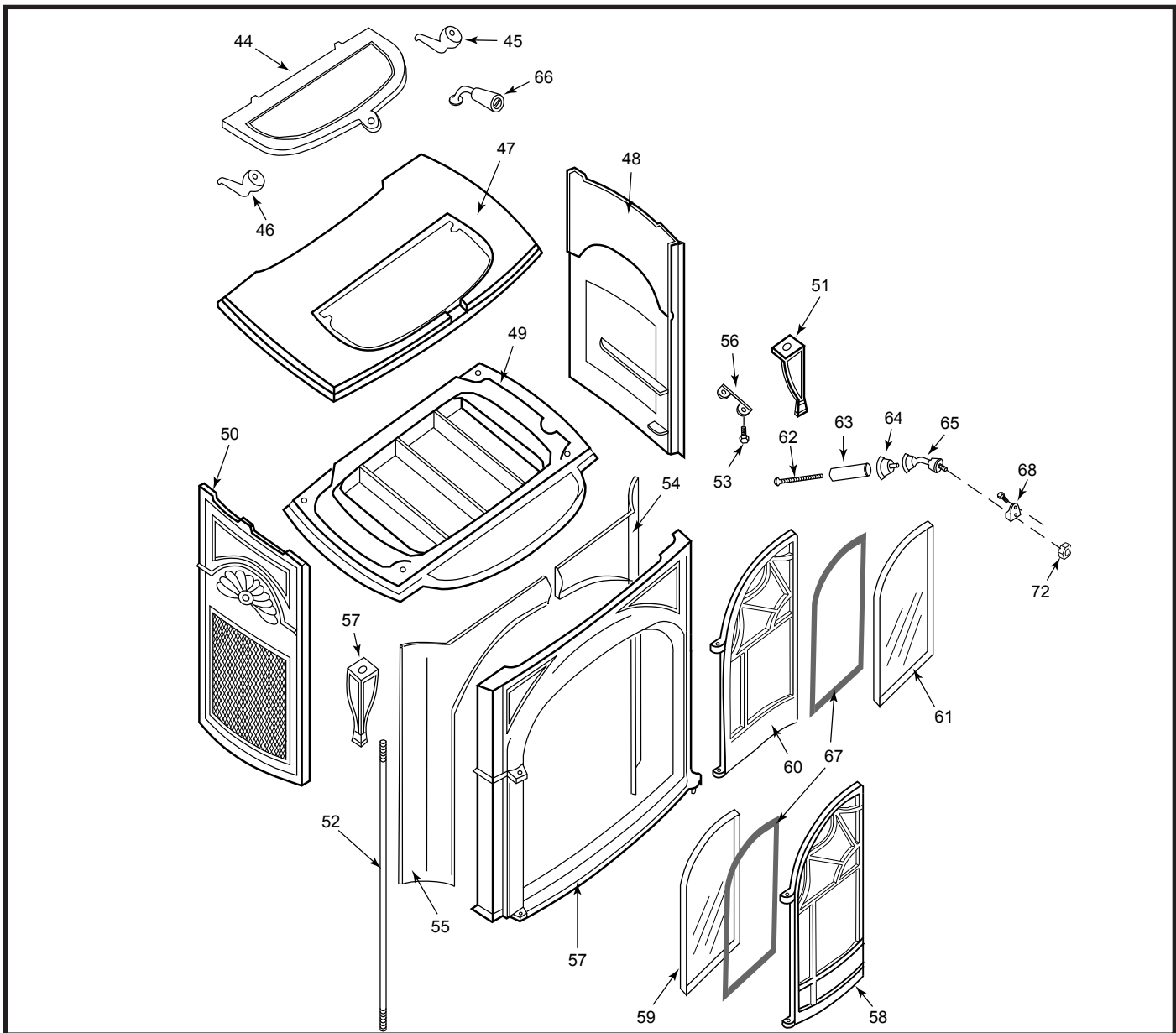
# Intrepid II Woodburning Stove

## Model 1990

Item Description	Part Number
1. Secondary Air Cover	1306762
2. Flue Collar	See Chart Pg. 36
3. Back Panel	1308662
4. Damper Rod	1602523
5. Damper Clip	1306725
6. Damper	1306701
7. Damper Housing	1306702
8. Throat Hood	1306763
9. Weld Screw	1201583
10. Upper Fireback	1306703
11. Fireback Clamp	1306724

Item Description	Part Number
12. 3/8" - 16 x 1 1/2" Hex Bolt	1201456
13. Lower Fireback	1306704
15. Rear Air Tube	1308658
16. Thermostat Cover	1306711
17. Damper Handle Assembly	5004265
18. Friction Spring	1201846
20. Thermostat Clip	1601408
21. Ball Chain Fitting (2)	1201972
22. Ball Chain	1201960
22a. Thermostat Assembly	5005506
23. Primary Air Flap	1306710





Vermont Castings Group reserves the right to make changes in design, materials, specifications, prices and discontinue colors and products at any time, without notice.

## Intrepid II Woodburning Stove Model 1990 (continued)

Item Description	Part Number
24. Air Flap Pin	1601551
25. Clip	1601396
26. #10-24 x 3/8" Pan Head Bolt	1200983
27. #10-24 x 1/4" Pan Head Bolt	1200980
28. Secondary Probe Assembly	1601489
29. Secondary Air Link	1601486
30. Phillips Bolt, 1/4"-20 x 5/8"	1200896
31. Shim Ring	1201986
32. Secondary Air Flap	1601490
33. Refractory Chamber w/ Access Panel	1602527
34. Catalyst Block	30004590

Item Description	Part Number
35. Refractory Access Panel	1602516
36. Andiron	1306717
37. Left Insert	1308651
38. Grate	1308652
39. Right Insert	1308650
40. Ashpan Only	1400951
41. Ashpan Front Only	1306493
42. Ashpan Handle	30000973
43. Damper Tab	1601488
44. Griddle	1306356

## Intrepid II Woodburning Stove

### Model 1990 (continued)

Item Description	Part Number
45. Right Griddle Quad (Pre-2010)	1301832
45a. Right Griddle Quad	30005119
46. Left Griddle Quad (Pre-2010)	1301807
46a. Left Griddle Quad	30005118
47. Top	See Chart Pg. 36
48. Right Side	See Chart Pg. 36
49. Bottom	See Chart Pg. 36
50. Left Side	See Chart Pg. 36
51. Leg	See Chart Pg. 36
52. Tie Rod	1601640
53. Leg Bolt, 3/8"-16 x 1" Hex Bolt	1201432
54. Right Air Manifold	1308654
55. Left Air Manifold	1308653
56. Handle Holder	1600600
57. Front	See Chart Pg. 36
58. Left Door	See Chart Pg. 36
59. Left Glass Panel <sup>1</sup>	1401157
60. Right Door	See Chart Pg. 36
61. Right Glass Panel <sup>1</sup>	1401156
62. Handle Bolt, 1/4"-20 x 3Z	1201310
63. Handle Wood	1600664
64. Handle Insert	30002714
65. Front Door Handle	30002719
66. Griddle Handle Assembly	30002775
67. Gasket, Fiberglas 3/16" Rnd, Blk	1203556
68. Latch Assembly	30002362
69. Glass Clips, Bottom	30000832
70. Glass Clips, Side	30000833
71. Glass Clips, Top	30000834
72. Nut, Jam	1203290
73. Ashpan Assembly	5003522
74. Bottom Heat Shield Assy. (not shown)	30004020
75. C-Clip (not shown)	1204015
76. Wing Screw (not shown)	1201621

**Please record the following information  
for future reference.**

Stove Serial No. \_\_\_\_\_

Dealer \_\_\_\_\_

Phone \_\_\_\_\_

Date Purchased \_\_\_\_\_

Installer \_\_\_\_\_

Phone \_\_\_\_\_

Date Installed \_\_\_\_\_

**NOTES:**

1. The glass panels have a heat-reflective coating on the outside and are not interchangeable.

<b>Shell Enamel Parts - Intrepid II Model 1990</b>									
<b>Enamel Color</b>	<b>Top</b>	<b>Bottom</b>	<b>Left Side</b>	<b>Right Side</b>	<b>Flue Collar</b>	<b>Front</b>	<b>Left Door Only</b>	<b>Right Door Only</b>	<b>Single Leg</b>
Classic	1308657	1306764	1308656	1308655	1306561	1308647	1308649	1308648	1306333
Biscuit	30003180	30003174	30003176	30003175	30003181	30003177	30003179	30003178	30003182
Bordeaux	30006712	30006708	30006710	30006709	30006713	30006711	30006715	30006714	30006716
Brown Majolica	30004824	30004820	30004822	30004821	30004825	30004823	30004829	30004828	30004830
Chestnut Brown	30003190	30003184	30003186	30003185	30003191	30003187	30003189	30001888	30003192
Ebony	30003200	30003194	30003196	30003195	30003201	30003197	30003199	30003198	30003202
Forest Green	2318657	2316764	2318656	2318655	2316561	2318647	2318649	2318648	2316333
Midnight Blue	2378657	2376764	2378656	2378655	2376561	2378647	2378649	2378648	2376333
Sand	1328657	1326764	1328656	1328655	1326561	1328647	1328649	1328648	1326333
Suede Brown	30002571	30002567	30002569	30002568	30002508	30002570	30002506	30002505	30002509
Vt. Classic Green	30003210	30003204	30003206	30003205	30003211	30003207	30003209	30003208	30003212







# Warranty

## Limited 3 Year Warranty

Vermont Castings Group warrants that this woodburning stove will be free of defects in material and workmanship for a period of three years from the date you receive it, except that the catalyst, thermostat assembly, handles, glass door panels, cement, and gasketing shall be warranted as described below.

Vermont Castings Group will repair or replace, at its option, any part found to be defective upon inspection by a Vermont Castings, Authorized Dealer. The customer must return the defective part or the stove, with shipping prepaid, to the Authorized Dealer or pay for any Authorized Dealer in-home travel fees or service charges for in-home repair work. It is the dealer's option whether the repair work will be done in the customer's home or in the dealer's shop. If, upon inspection, the damage is found to be the fault of the manufacturer, repairs will be authorized at no charge to the customer for parts and/or labor.

Any woodburning stove or part thereof that is repaired or replaced during the limited warranty period will be warranted under the terms of the limited warranty for a period not to exceed the remaining term of the original limited warranty or six (6) months, whichever is longer.

## Limited 1 Year Warranty

The following parts of the woodburning stove are warranted to be free of defects in material and workmanship for a period of one year from the date you receive it: The thermostat assembly, handles, glass door panels, cement, and gasketing. Any of these items found to be defective will be repaired or replaced at no charge, upon the return of the part with postage prepaid to a Vermont Castings Authorized Dealer.

Any part repaired or replaced during the limited warranty period will be warranted under the terms of the limited warranty for a period not to exceed the remaining term of the original limited warranty or six (6) months, whichever is longer.

## Limited Catalyst Warranty

The catalyst will be warranted for a six year period as follows: If the original catalyst or a replacement catalyst proves defective or ceases to maintain 70% of its particulate emission reduction activity (as measured by an approved testing procedure) within 24 months from the date the stove is received, the catalyst itself will be replaced free.

From 25 - 72 months a pro-rated credit will be allowed against a replacement catalyst and the cost of labor necessary for its installation at the time of replacement.

For stove purchases made after June 30, 1990, a third year (25 - 36 months) of no charge replacement will be made when combustor failure is due to thermal degradation of the substrate (crumbling of ceramic material). The customer must pay for any in-home travel fees, service charges, or transportation costs for returning the stove to the Authorized Dealer.

Amount of Time Since Purchase	Credit Towards Replacement Cost
0 - 24 months	100%
25 - 36 months	50%
37 - 48 months	30%
49 - 60 months	20%
61 - 72 months	10%

Any replacement catalyst will be warranted under the terms of the catalyst warranty for the remaining term of the original warranty. The purchaser must provide the following information in order to receive a replacement catalyst under the terms of this limited warranty:

1. Name, address and telephone number.
2. Proof of original purchase date.
3. Date of failure of catalyst.
4. Any relevant information or circumstances regarding determination of failure.
5. In addition, the owner must return the failed catalyst.

## Exclusions & Limitations

1. This product must be installed or serviced by a qualified installer, preferably NFI or WETT (Canada) certified, as prescribed by the local jurisdiction. It must be installed and operated at all times in accordance with the Installation and Operating instructions furnished with the product any alteration, willful abuse, accident or misuse of this product shall nullify this warranty.
2. This warranty is transferable; however, proof of original retail purchase is required.
3. This warranty does not cover misuse of the stove. Misuse includes overfiring which will result if the stove is used in such a manner as to cause one or more of the plates to glow red. Overfiring can be identified later by warped plates and areas where the paint pigment has burned off. Overfiring in enamel fireplaces is identified by bubbling, cracking, chipping and discoloration of the porcelain enamel finish. Vermont Castings Group offers no warranty on chipping of enamel surfaces. Inspect your woodburning stove prior to accepting it for any damage to the enamel.
4. This warranty does not cover misuse of the stove as described in the Owner's Guide, nor does it cover a stove which has been modified unless authorized by a Vermont Castings Group representative in writing. This warranty does not cover damage to the stove caused by burning salt saturated wood, chemically treated wood, or any fuel not recommended in the Owner's Guide.
5. This warranty does not cover a stove repaired by someone other than a Vermont Castings Authorized Dealer.
6. Damage to the unit while in transit is not covered by this warranty but is subject to a claim against the common carrier. Contact Vermont Castings Authorized Dealer from whom you purchased your stove or Vermont Castings Group if the purchase was direct. (Do not operate the stove as this may negate the ability to process the claim with the carrier.)
7. Claims are not valid where the installation does not conform to local building and fire codes or, in their absence, to the recommendations in our Owner's Guide.
8. The salt air environment of coastal areas, or a high-humidity environment, can be corrosive to the porcelain enamel finish. These conditions can cause rusting of the cast iron beneath the porcelain enamel finish, which will cause the porcelain enamel finish to flake off. This warranty does not cover damage caused by a salt air or high-humidity environment.
9. Vermont Castings Group shall have no obligation to enhance or update any unit once manufactured.

IN NO EVENT SHALL Vermont Castings Group BE LIABLE FOR INCIDENTAL AND CONSEQUENTIAL DAMAGES. ALL IMPLIED WARRANTIES, INCLUDING THE IMPLIED WARRANTIES OF MERCHANTABILITY AND FITNESS, ARE LIMITED TO THE DURATION OF THIS WRITTEN WARRANTY. THIS WARRANTY SUPERCEDES ALL OTHER ORAL OR WRITTEN WARRANTIES.

Some states do not allow the exclusion or limitations of incidental and consequential damages or limitations on how long an implied warranty lasts, so the above limitations may not apply to you. This warranty gives you specific rights and you may have other rights which vary from state to state.

## How to Obtain Service

If a defect is noted within the warranty period, the customer should contact a Vermont Castings Authorized Dealer or Vermont Castings Group if the purchase was direct with the following information:

1. Name, address, and telephone number of the purchaser.
2. Date of purchase.
3. Serial number from the label on the back.
4. Nature of the defect or damage.
5. Any relevant information or circumstances, e.g., installation, mode of operation when defect was noted.

A warranty claim will then start in process. Vermont Castings Group reserves the right to withhold final approval of a warranty claim pending a visual inspection of the defect by authorized representatives.

**Vermont Castings Group**

149 Cleveland Drive • Paris, Kentucky 40361  
[www.vermontcastingsgroup.com](http://www.vermontcastingsgroup.com)