

BOILER INSTALLATION, OPERATION INSTRUCTIONS

Riva

PLUS COMBI

WALL HUNG GAS BOILER FOR
CENTRAL HEATING SUPPLY

**Please Read Instructions Carefully
Save for Future Reference**

WARNING: If the information in this manual is not followed exactly, a fire or explosion may result causing property damage, personal injury or loss of life.

- Do not store or use gasoline or other flammable vapors and liquids in the vicinity of this or any other appliance.
- **WHAT TO DO IF YOU SMELL GAS**
 - Do not try to light any appliance.
 - Do not touch any electric switch; do not use any phone in your building.
 - Immediately call your gas supplier from a neighbor's phone. Follow the gas supplier's instructions.
 - If you can not reach your gas supplier call the fire department.
- Installation and service must be performed by a qualified installer, service agency or the gas supplier.

Manufactured by:

BIASI

Biasi S.p.A.
Verona, Italy



Distributed By:

QHT
INCORPORATED

Quincy Hydronic Technologies, Inc.
80 Rochester AVE. Suite # 12
Portsmouth, NH 03801
Phone: 603-334-6400
Fax: 603-334-6401

MANUEL RIVA COMBI - REV A

Dear Customer:

Thank you for buying a Biasi Riva Plus Combi.

The Riva Plus Combi is a high efficiency condensing, wall mounted gas boiler which provides central heat supply water.

We realize that it is not possible to answer all questions about the Riva Plus Combi system in this manual. Reading this installation manual does not make the reader an expert in all aspects of installation and operation, and does not replace the need for a qualified, licensed heating contractor. We urge you to contact your installing contractor or distributor if you are in question about any aspect of your boiler's performance. Our main concern is that you are satisfied with your boiler and its performance. We require that your contractor complete efficiency tests using instruments.

The external controls and accessories listed in this manual (excluding those supplied inside the boiler) are intended to serve as guidelines rather than specific recommendations. We realize that other makes and models of such devices are available and can be used as successfully as those we specify. The installing contractor is the best judge of a system's specific requirements, as well as the local availability of certain makes and models of controls and accessories. The preceding does not apply, however, to the equipment that comes with every boiler, such as the overheat control and pressure relief valves. **The installation of the specific devices supplied with every boiler is absolutely necessary to the safe operation of the boiler and protection of the heating system.**

All BIASI wall hung boilers are built in accordance with the ASME boiler and pressure vessel code, and bear the "H" stamp. The Entire range of applications for the Riva Plus Combi has been tested to standard CSA 4.9 and is CSA compliant.

This Riva Plus Combi has a 2 year warranty, a copy of which is provided with the boiler. Please be sure to return the warranty registration card as the warranty will be void without your boiler's serial numbers (located on the ratings label affixed to the boiler), date of installation and the name of your installer being on record in our files.

Thank you for purchasing our Riva Plus Combi. If you have questions or comments, please don't hesitate to contact us immediately. Our goal is 100% customer satisfaction.

QHT inc.

Table of Contents

Section Title	Section Number	Page Number
Warnings	-	5-6
Important Information	-	7
General Information	1	8
Technical Information (M135.30CM)	2	8-9
Parts List	3	10
Internal Piping and Parts List	4	11
Electric Diagrams	5	12
Sequence of operation	5.1	13
Installation Location	6	14
Exhaust Pipe Location	7	15
Mounting Bracket	8	16
Venting	9	17-24
Restrictor Sizing	9.1	18
Fitting the Flue System	9.2	18
Choice of Flue	9.3	19-24
Pipe Connections	10	25
Gas Pipe Connections	11	26
Electrical Connections/Wiring	12	27-29
Power Connection	12.1	27
Connection to the Electricity Supply	12.2	27
Room Thermostat Connection	12.3	28
Relay Panel Control Connection	12.4	28
Zone Valve Microswitch Connection	12.5	29
Finishing	12.6	29
Circulator Sizing	13	30
Circ. Cap. as a Function of Flow Rate	13.1	30
Expansion Vessel	13.2	30
Piping	14	31-34

Table of Contents

Section Title	Section Number	Page Number
Primary-Secondary with Zone Valves	14.2	33
Manifold Piping with Zone Valves or Circ.	14.3	34
Commissioning	15	35-41
Initial Filling of the System	15.1	35
Lightning the Boiler	15.2	35
Checking the Gas Pres. at the Burner	15.3	36
Adjustment of the Gas Pressure	15.4	37
Checking the Ignition Device	15.5	37
Checking the Burner Ignition	15.6	38
Adjustment of the Useful c.h. Output	15.7	38
Labels Placement	15.8	38
Checking the Flue System and Comb.	15.9	39
Instructing the User	15.10	40
Gas Conversion	16	41
Annual Maintenance	17	42-44
Warnings	17.1	42
Dismantelling the External Panels	17.2	42
Emptying the C.h. System	17.3	42
Emptying the D.h.w.circuit	17.4	43
Cleanig the Burner.	17.5	43
Checking the combustion fan	17.6	43
Checking the Flue	17.7	43
Checking the press. in the exp.vassel	17.8	44
Visual Inspection of Appliance	17.9	44
Gas Pressures and Soundness	17.10	44
Cleanig the primary heat exchanger	17.11	44
Cleanig the domestic hot water exchanger	17.12	44
Condensate trap	17.13	44
Vent Part Spares	18	45-47
Installer Notes	19	48

WARNING

Boiler is certified as an indoor appliance. Do not install boiler outdoors or locate where it will be exposed to freezing temperatures.

WARNING: If the information in this manual is not followed exactly, a fire or explosion may result causing property damage, personal injury or loss of life.

- Do not store or use gasoline or other flammable vapors and liquids in the vicinity of this or any other appliance.
- **WHAT TO DO IF YOU SMELL GAS**
 - Do not try to light any appliance.
 - Do not touch any electric switch; do not use any phone in your building.
 - Immediately call your gas supplier from a neighbor's phone. Follow the gas supplier's instructions.
 - If you can not reach your gas supplier call the fire department.
- Installation and service must be performed by a qualified installer, service agency or the gas supplier.

DANGER

Caution: Do not store or use flammable materials, chemicals or flammable liquids, especially gasoline, in the vicinity of this heating appliance.

Caution: Should overheating occur or the gas supply fail to shut off, do not turn off or disconnect the electrical supply to the pump. Instead, shut off the gas supply at a location external to the appliance.

Caution: Do not use this boiler if any part has been under water. Immediately call a qualified service technician to inspect the boiler and to replace any part of the control system and any gas control which has been under water.

WARNING

Any appliance that burns natural gas, propane gas, fuel oil, wood or coal is capable of producing carbon monoxide (CO). Carbon Monoxide (CO) is a gas which is odorless, colorless and tasteless but is very toxic. CO is lighter than air and thus may travel throughout the building.

BRIEF EXPOSURE TO HIGH CONCENTRATIONS OF CO, OR PROLONGED EXPOSURE TO LESSER AMOUNTS OF CO MAY RESULT IN CARBON MONOXIDE POISONING. EXPOSURE CAN BE FATAL AND EXPOSURE TO HIGH CONCENTRATIONS MAY RESULT IN THE SUDDEN ONSET OF SYMPTOMS INCLUDING UNCONSCIOUSNESS.

Symptoms of CO poisoning include the following:

dizziness	vision problems	shortness of breath
headache	loss of muscle control	unclear thinking
nausea	weakness	unconsciousness

The symptoms of CO poisoning are often confused with those of influenza, and the highest incidence of poisoning occurs at the onset of cold weather or during flu season.

A victim may not experience any symptoms, only one symptom, or a few symptoms.

Suspect the presence of carbon monoxide if symptoms tend to disappear when you leave your home.

The following signs may indicate the presence of carbon monoxide:

- Hot gasses from appliance, venting system pipes or chimney, escaping into the living space.
- Flames coming out around the appliance.
- Yellow colored flames in the appliance.
- Stale or smelly air.
- The presence of soot or carbon in or around the appliance.
- Very high unexplained humidity inside the building.

If any of the symptoms of CO occur, or if any of the signs of carbon monoxide are present, **VACATE THE PREMISES IMMEDIATELY AND CONTACT A QUALIFIED HEATING SERVICE COMPANY OR THE GAS COMPANY OR THE FIRE DEPARTMENT.**

ONLY QUALIFIED, LICENSED SERVICE CONTRACTORS SHOULD PERFORM WORK ON YOUR BIASI RIVA COMBI BOILER.

IMPORTANT INFORMATION
Please read this page carefully.

- **ALL BOILERS MUST BE INSTALLED IN ACCORDANCE WITH NATIONAL, STATE AND LOCAL PLUMBING, HEATING AND ELECTRICAL CODES AND ORDINANCES, AS WELL AS THE REGULATIONS OF THE SERVING ELECTRICAL, WATER AND GAS UTILITIES.**
- **All systems should be designed by competent contractors, and only persons knowledgeable in the layout and installation of heating systems should attempt the installation of any boiler. It is the responsibility of the installing contractor to see that all controls are correctly installed and operating properly when the installation is completed.**
- **This boiler is intended for use, only with propane or natural gas. All flammable liquids (especially gasoline), chemicals, rags, paper, wood scraps, debris, etc., should be kept away from the boiler at all times. Keep the boiler area clean and free of all fire hazards.**
- **Please read the literature and warranties supplied by the manufacturers of the various accessory equipment. This equipment is warranted by the respective manufacturers, not by Quincy Hydronic Technologies, Inc. Each piece of equipment must be installed and used according to the recommendations of the manufacturer.**

Codes and Regulations:

Installation of the boiler and related equipment must conform to national, state and local regulating agencies and codes applicable to the installation of the equipment. In the absence of local requirements, the following codes apply:

- | |
|---|
| A. ANSI/NFPA - #70 National Electric Code |
| B. ANSI/NFPA - #211 Chimneys and Vents |
| C. ANSI/NFPA - #Z223.1 National Fuel Gas Code |
| C. ANSI/NFPA - Domestic Gas Conversion Burner |
| D. CAN/CGA - B149 Installation Codes |
| E. ANSI/ASME - CSD-1 |

The above codes are available from:

National Fire Protection Association (NFPA)
Battery March Park
Quincy, Massachusetts, 02269
<http://www.nfpa.org>

CSA International
8501 E. Pleasant Valley Road
Cleveland, OH 44134-5575
<http://www.csa-international.org>

1. General Information

The Riva Plus Combi is a high efficiency condensing, wall mounted gas boiler which provides central heat. The boiler features a gas valve which modulates the energy input from 49476 BTU/h to 116008 BTU/h. The boiler is shipped fully assembled with the components listed on page 11. All units are pressure and combustion tested at the factory prior to shipping.

Key Features:

- Wall mountable - saving valuable floor space.
- Several flue options available
- Electronic spark ignition
- Safety flow switch - positioned on the main circuit, which monitors the flow and protects the main heat exchanger from thermal shock should there be a lack of water in the system.
- Frost protection - contains an integral frost protection system to prevent frost damage which can occur in areas susceptible to very cold weather conditions.
- Boiler operation recognition system - should the boiler not be used for longer than 24 hours, it then performs a controlled system test to ensuring the motorized components within the boiler do not become inoperable due to lack of use.
- Gas valve modulation - the gas input modulates based off central heating temperature to within ± 2 °F
- Diagnostic information system equipped with three LED diagnostic lights for quick error assessment.

2. Technical Information (M135.30CM)

GENERAL		
Height	in	31.6
Width	in	15.7
Depth	in	13.8
Weight	lb	109.5

ELECTRICAL		
Voltage	V	120
Frequency	Hz	60
Current	A	1.6
Power consumption	W	180

INJECTORS	No.	Size
Natural	14	130
Propane	14	89

CENTRAL HEATING		
Maximum working temp.	°F	185
Temp. Regulation range*	°F	100-176
Maximum pressure	psi	30.0
Minimum pressure	psi	4.35
Max head loss (at 4.4 GPM)	ft	8.25
*At the minimum useful output		

2. Technical Information Cont.

ENERGY CAPACITY		
Nominal heat input (0/2000ft)	MBH	116.0
Nominal heat input (2000/4500ft)	MBH	110.2
Minimum heat input	MBH	49.5
Maximum useful output (0/2000ft)	MBH	102.0
Maximum useful output (2000/4500ft)	MBH	97.2
Minimum useful output	MBH	41.6

GAS SUPPLY PRESSURE				
Gas		Normal	Min	Max
Natural	inwc	7.0	3.5	10.5
Propane	inwc	11.0	8.0	13.0

GAS PRESSURE AT BURNER				
Gas		Min	Max	Ignition
Natural	inwc	1.0	4.8	2.4
Propane	inwc	2.0	10.3	5.2

FLUE DESIGN		
Minimum Venturi pressure	inwc	0.64
Flue pipe diameter		
Coaxial	in	2.25/4 3.25/5
Twin split pipes	in	3.25/3.25
Nominal heat flow rate (0/2000ft)	MBH	116.0
Nominal heat flow rate (2000/4500ft)	MBH	110.2
Min Exhaust temperature	°F	130
Max Exhaust temperature	°F	195

GAS FLOW RATE			
Gas		Min	Max
Natural	ft ³ /h	48.7	115.1
Propane	lb/h	2.2	5.2

CLEARANCE TO COMBUSTIBLES		
Front	in	18
Back	in	0
Top	in	8
Sides	in	2
Bottom	in	8
Flue pipe enclosed	in	2
Flue pipe free air	in	0

FLUE GAS FIGURES		
Gas	Min	Max
CO ₂	2.5%	6.3%
O ₂	16.5%	9.7%

DOMESTIC HOT WATER		
Maximum temperature	°F	131
Minimum temperature	°F	95
Maximum pressure	psi	145
Minimum pressure	psi	4.35
D.h.w. ΔT 25K	gal/h	4.5
D.h.w. ΔT 30 K	gal/h	3.8
D.h.w. ΔT 35 K	gal/h	3.2
D.h.w. ΔT 40 K	gal/h	2.8

3. Parts List

Primary Components:

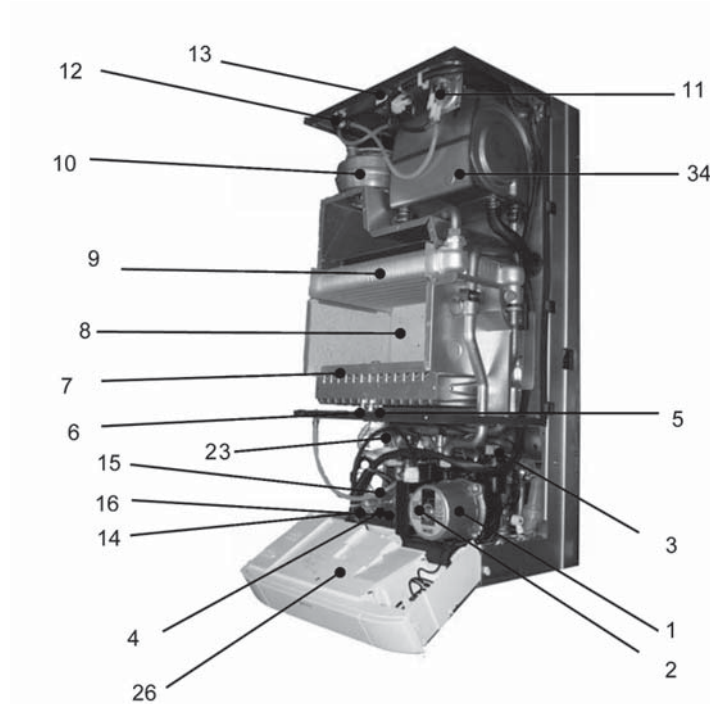

- | | |
|---|--|
| 1. Pump | 22. By-pass valve |
| 2. Pump vent plug | 23. Three-way diverter valve |
| 3. Automatic air purger valve | 24. Venturi device |
| 4. Modulation gas valve | 25. Flue outlet pipe |
| 5. Flame-detecting electrode | 26. Air Intake Pipe |
| 6. Ignition electrodes | 27. Control panel |
| 7. Burner | 28. Safety thermostat probe |
| 8. Combustion chamber | 29. Pressure reducing automatic fill valve |
| 9. Primary heat exchanger | 30. Backflow preventer |
| 10. Fan | 31. Gas supply line cock |
| 11. Air pressure switch | 32. Water supply inlet cock |
| 12. Air switch pres. Test points | 33. Condensate trap |
| 13. Safety thermostat | 34. Condensing heat exchanger |
| 14. Modulation operator | 35. Flue thermostat |
| 15. Gas valve outlet pres. Test point | 36. D.h.w heat exchanger |
| 16. Gas valve inlet pres. Test point | 37. D.h.w flow switch |
| 17. Central heating expansion vessel | 38. Domestic water circuit filter |
| 18. Central heating temp. Probe NTC | 39. D.h.w flow limiter |
| 19. Central heating pressure relief valve | 40. Domestic hot water temp.probe NTC |
| 20. Primary circuit flow switch | 41. Domestic cold water inlet valve |
| 21. Main circuit drain cock | 42. D.h.w. outlet pipe |

4. Internal Piping & Parts List

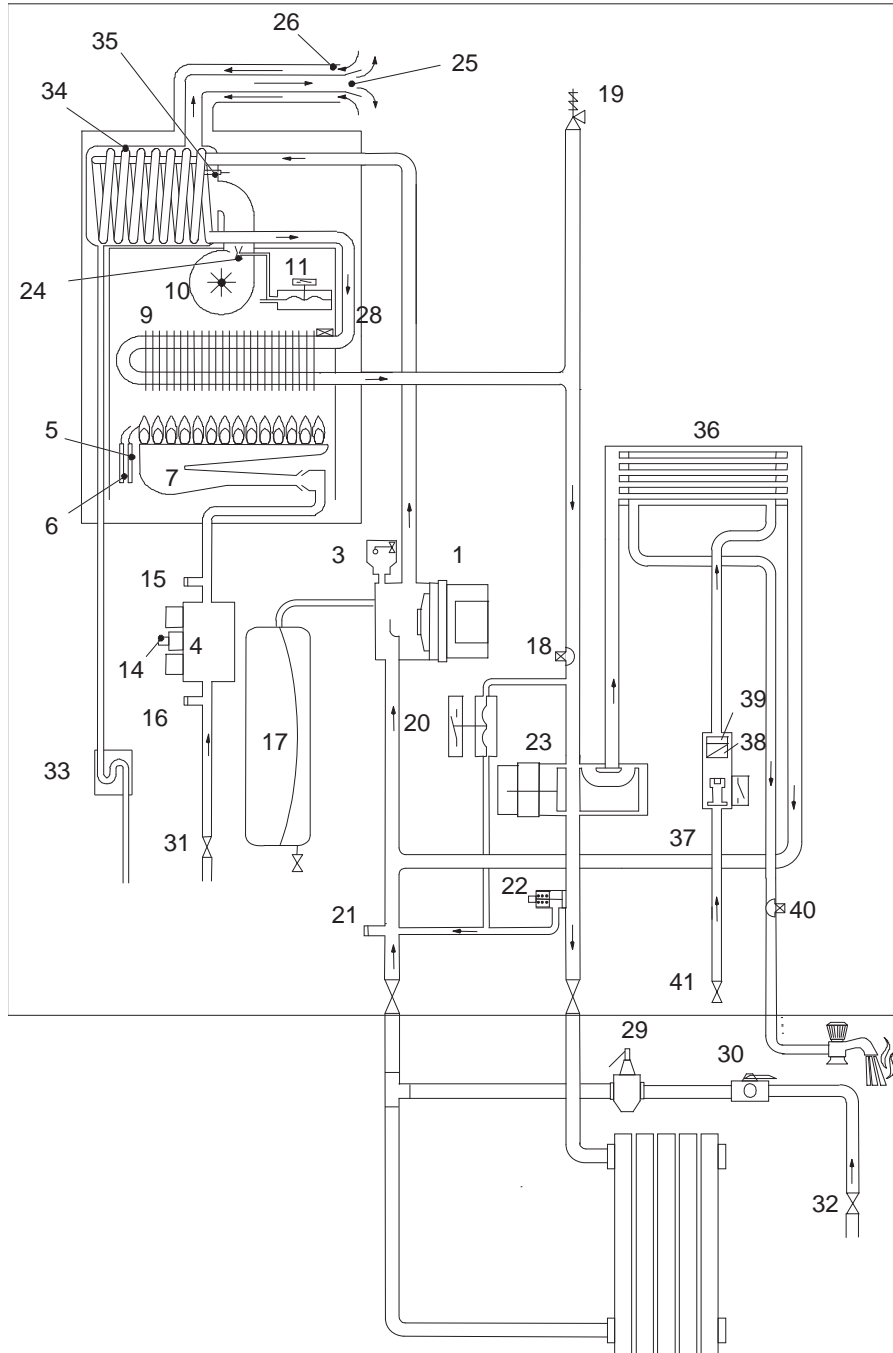

Note: Pressure Relief Valve (#19) should be piped to a drain or to the floor as close as possible to a drain.

5. Electric Diagrams

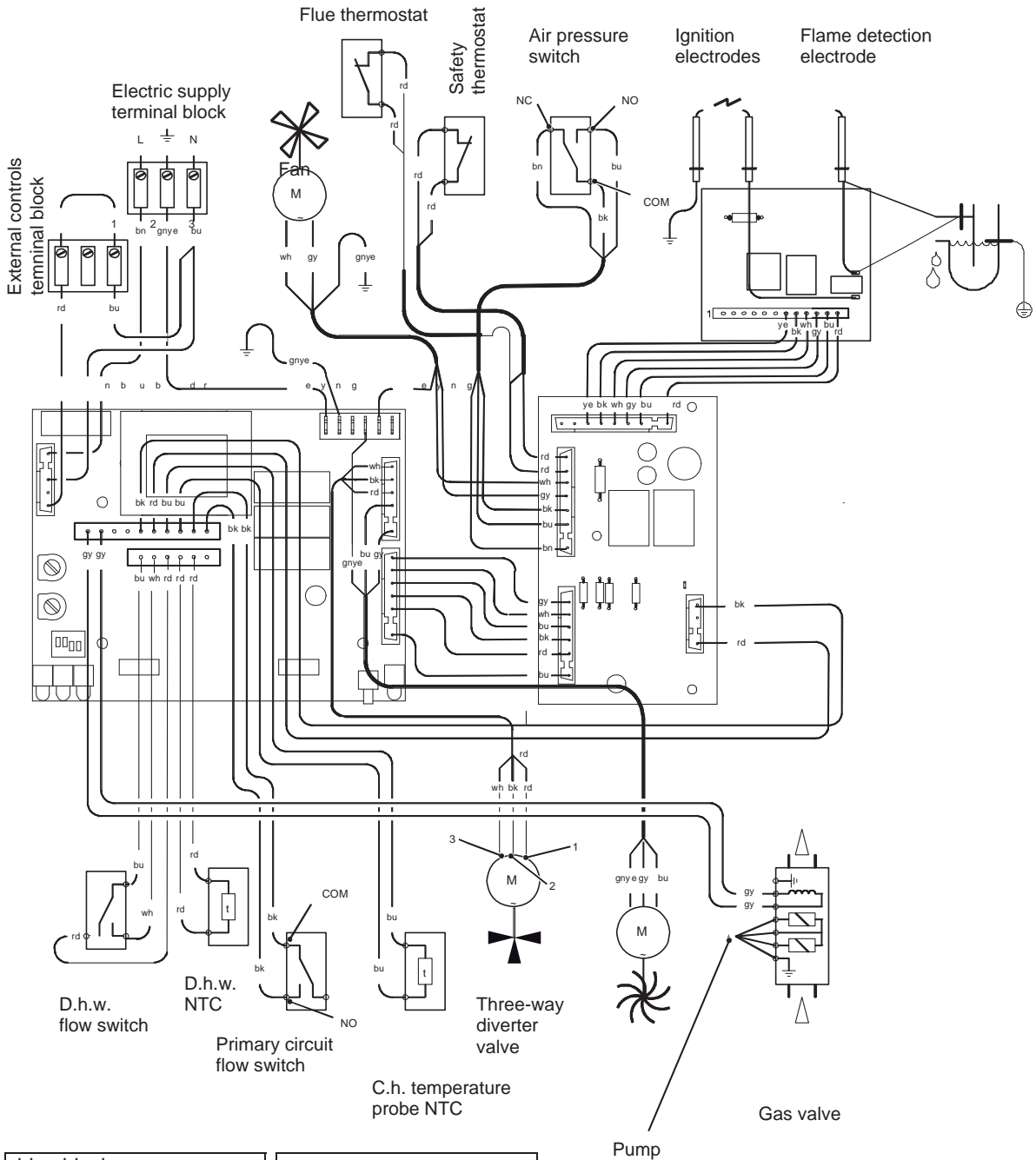

bk – black	gy – grey
bn – brown	rd – red
bu – blue	wh – white
gnye – green/yellow	ye – yellow

Caution:
Label all wires prior to disconnection when servicing controls. Wiring errors can cause improper and dangerous operation.
Verify proper operation after servicing.

5. Electric Diagrams Cont.

5.1 Sequence of Operation

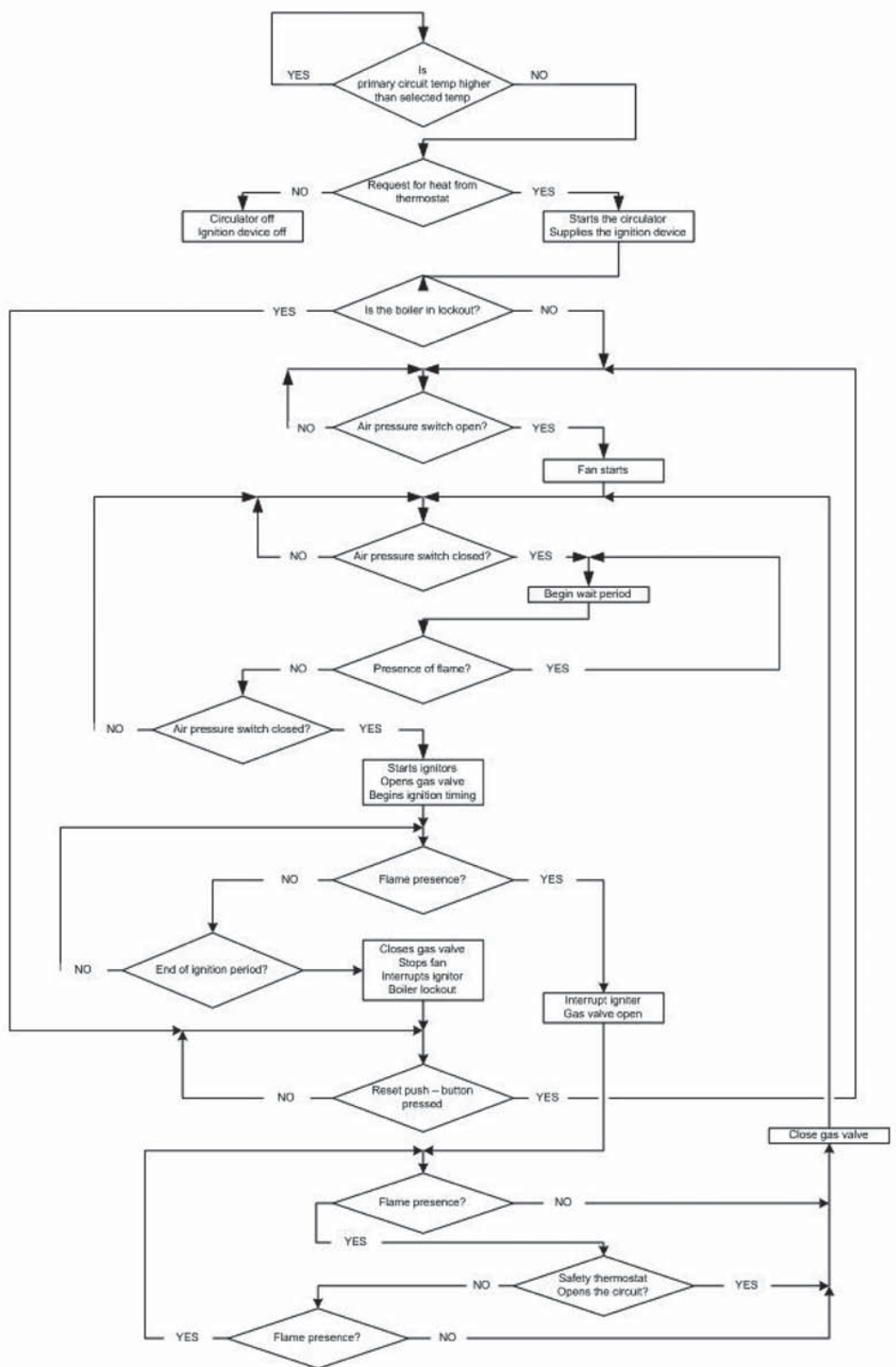

6. Installation Location

The installation location chosen must:

- Comply with all clearances listed below.
- Provide suitable location for the exhaust and intake venting.
- Not be installed in an unheated space.
- Comply with all local codes and standards.

Note: Dimensions shown are minimums. Greater clearances will simplify installation and service.

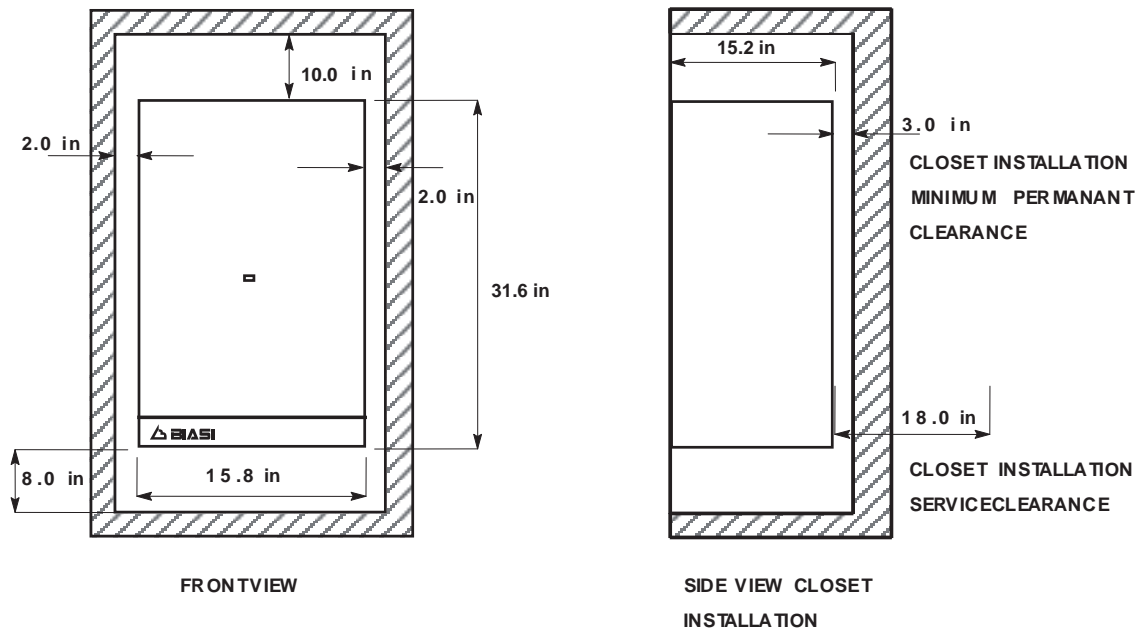

Figure 6.1

WARNING: Do not install the boiler on carpeting

If the boiler is to be installed in an enclosed room with no fresh air intake, the room must have proper vent louvers installed. There should be two louvers, place each within 12" of the ceiling and floor respectively. Each vent will have a free area of 54 square inches.

Note: For boilers in an enclosed space it is recommended to install a CO detector in the boiler room.

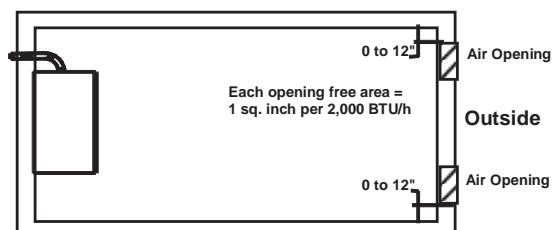

Figure 6.2

When choosing an installation location insure the exhaust and intake pipes comply with NFPA 54. The drawing on the next page illustrates the restrictions on exhaust locations.

7. Exhaust Pipe Location

CAUTION

EXTERNAL VENT SURFACES ARE HOT.

IT IS RESPONSABILITY OF THE HOMEOWNER TO KEEP THE VENT TERMINAL CLEAR OF SNOW AND ICE

NOTE: USE ONLY LISTED COMPONENTS SUPPLIED WITH THE BOILER. SURFACE DISCOLORATION OF THE BUILDING MAY OCCUR DUE TO IMPROPER INSTALLATION. QHT WILL NOT ACCEPT RESPONSIBILITY OR LIABILITY FOR SUCH DISCOLORATION.

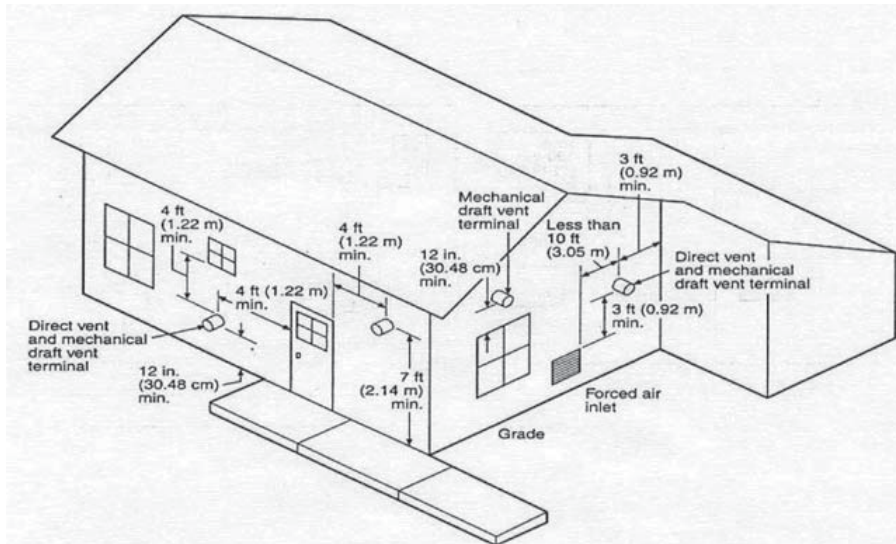

The Exhaust Hood must be installed on the leeward side of house and conform to the following guidelines:

1. The Vent hood shall not be less than 3 feet above any forced air inlet to the house.
2. The Vent hood shall not be less than 4 feet below, 4 feet horizontally, or 1 foot above any door, window or gravity inlet into any building.
3. The Vent hood shall not be less than 2 feet from an adjacent building.
4. The Vent hood shall be not less than 7 feet above grade when located adjacent to public walkway.
5. The Vent hood shall be located so that flue gasses are not directed to jeopardize people, overheat combustible structures, materials or enter buildings.
6. Minimum of 4 feet horizontal clearance from electric meters, gas meters, regulators and relief equipment.
7. **All joints in system are to be sealed to prevent leakage of products of combustion in the building.**
8. Avoid installing exhaust hood on the North, West, or the side of the house receiving the prevailing winds.
9. The vent should not be situated so that the flue gasses are directed towards brickwork, siding, or other construction, in such a manner that may cause damage from heat or condensate from the flue gasses

9. Venting

The Riva Plus Combi is a mechanical draft, side wall vented boiler. There are two side wall flue options available – separate and coaxial. The coaxial option has one configuration shown on the next page. The separate option has two possible configurations shown on the following pages. There is also a vertical roof venting option. Regardless of what vent kit is installed, they should all conform to the **Provisions for combustion and ventilation air in accordance with section 5.3, Air for Combustion and Ventilation, of the National Fuel Gas Code, ANSI Z223.1, or Sections 7.2, 7.3 or 7.4 of CAN/CGA B149, Installation Codes, or applicable provisions of the local building codes.**

If the Biasi Riva Plus Combi replaces a boiler that was attached to a common vent system, the common venting system is likely to be too large for proper venting of the appliances remaining connected to it. To ensure the remaining appliances will function properly, the test procedure below should be followed:

At the time of removal of an existing boiler, the following steps shall be followed with each appliance remaining connected to the common venting system placed in operation, while the other appliances remaining connected to the common venting system are not in operation.

- (a) Seal any unused openings in the common venting system.
- (b) Visually inspect the venting system for proper size and horizontal pitch and determine there is no blockage or restriction, leakage, corrosion and other deficiencies which could cause an unsafe condition.
- (c) Insofar as is practical, close all building doors and windows and all doors between the space in which the appliances remaining connected to the common venting system are located and other spaces of the building. Turn on clothes dryers and any appliance not connected to the common venting system. Turn on any exhaust fans, such as range hoods and bathroom exhausts, so they will operate at maximum speed. Do not operate a summer exhaust fan. Close fireplace dampers.
- (d) Place in operation the appliance being inspected. Follow the lighting instructions. Adjust thermostat so appliance will operate continuously.
- (e) Test for spillage at the draft hood relief opening after 5 minutes of main burner operation. Use the flame of a match or candle, or smoke from a cigarette, cigar or pipe.
- (f) After it has been determined that each appliance remaining connected to the common venting system properly vents when tested as outlined above, return doors, windows, exhaust fans, fireplace dampers and any other gas-burning appliance to their previous condition of use.” (g) Any improper operation of the common venting system should be corrected so the installation conforms with the National Fuel Gas Code, ANSI Z223.1 and/or CAN/CGA B149, Installation Codes. When resizing any portion of the common venting system, the common venting system should be resized to approach the minimum size as determined using the appropriate tables in Part 11 of the National Fuel Gas Code, ANSI Z223.1 and/or CAN/CGA B149, Installation Codes.

9. Venting Cont.

The Riva is a mechanical draft, side wall vented boiler. There are two flue options available - separate and coaxial. The coaxial option has one configuration shown on the next page. The separate option has two possible configurations shown on the following pages.

9.1 Restrictor Sizing:

Each exhaust option is shipped standard with 3 feet of exhaust pipe, 3 feet of intake air pipe. There is also a restrictor kit in which there are some restrictors that must be placed in exhaust breach of fan on the top of the boiler (Fig. 9.1) according to the flue configuration used.

If additional flue piping is need for a particular application, it can be ordered separately in 3 feet increments. Depending on the final flue pipe length, an alternative restrictor may be required. Refer to the tables 9.1 for proper restrictor ring sizing.



Figura 9.1

Separate 3.25/3.25 Restrictor Size		Coaxial 2.5/4.0 Restrictor Size	
From 3.30 to 49.2 ft (in+out)	45	From 0 to 2.9 (ft)	82
		From 2.9 to 8.8 (ft)	No restrictor

Table 9.1

9.2 Fitting the flue system:

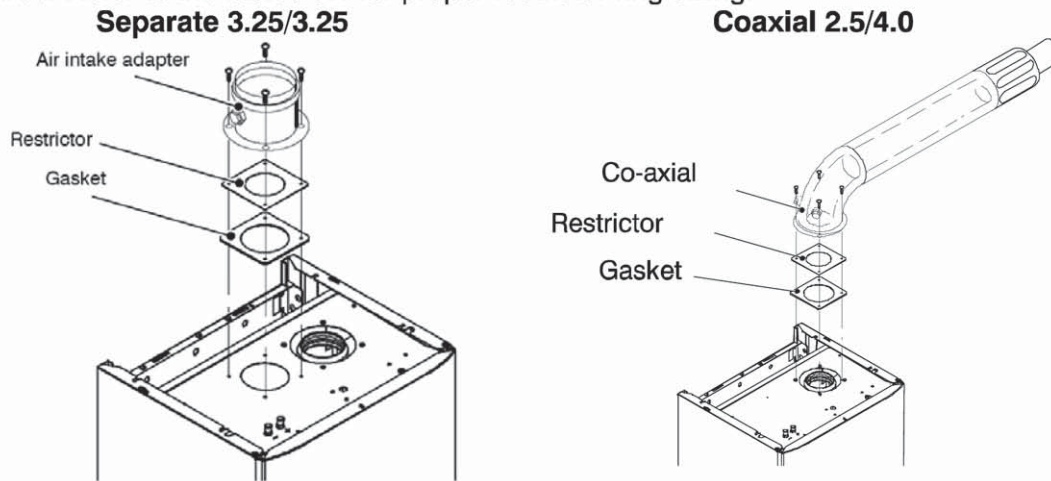
In general, it has to be taken in consideration that the orizontal sections of the flue pipe must have an horizontal sloping not less than 1.5 degree (0.3 in per ft) towards the boiler.

In the standard horizontal flue kit the flue pipe is angled within the air duct therefore the air duct must be horizontally installed.

If one or more exstensions have to be used they must be adequately supported so that there is no sag in the flue pipe and a minimum fall of 1.5 degree (0.3 in per ft) over the whole lenght towards the boiler is ensured.

9. Venting Cont.

9.3 Choice of flue:

The following flue kits are available for connecting to the boiler:

A Standard coaxial horizontal flue kit (Exhaust & intake outside)

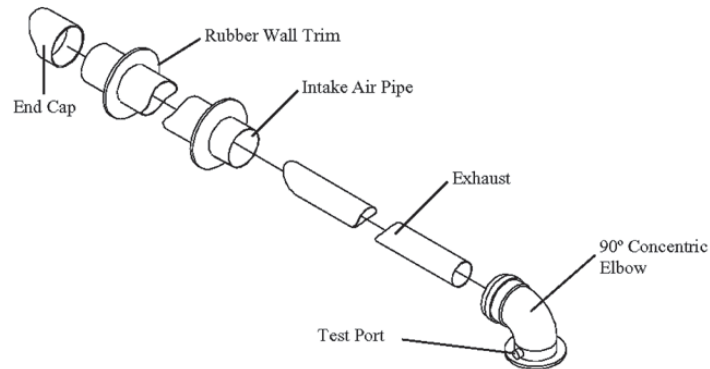

Figure 9.3 (Coaxial 2.4/4.0 inches – nominal length 3.3 ft)

It can be fitted to allow discharge to the rear or either side of the boiler via the flanged boiler adapter elbow. Minimum length required is 2.9 ft. Maximum equivalent length of 8.8 ft can be achieved utilising extensions. This flue system can only be used to discharge horizontally, it is not designed to enable termination in the vertical plane.

Installation:

- Drill hole A (on the wall template) through the outside wall that is less than 18" thick.
- Cut the pipe as necessary so that a no more than 6" protrudes from the house.
- Slide the intake and exhaust pipes through the hole.
- Slide one rubber wall trim piece on the pipe from inside and one from outside.
- Connect exhaust (inner) pipe to concentric elbow.
- Connect intake (outer) pipe to concentric elbow.
- Secure elbow to boiler using gasket and four screws provided.
- Secure end cap on the intake pipe outside the house.

9. Venting Cont.

B Standard separate horizontal flue kit (Exhaust & intake outside)

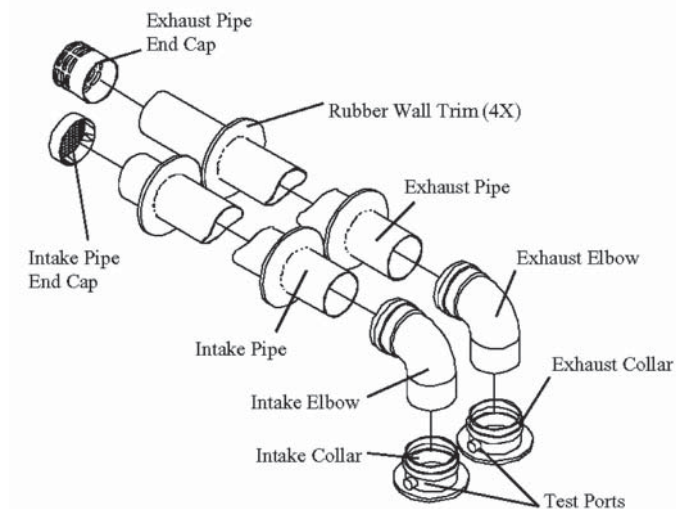

Figure 9.4 (Twin pipe Ø 3.25 in)

Various twin (split) pipes kits and optional accessories (elbows) are available to assist in the termination of the flue where the boiler is installed in a location remote to an outside wall. These kits allow for separation of the air supply pipe from the pipe that discharges the exhaust gasses. Consequently it is possible to extend the flue system to a greater distance than that provided by the standard coaxial horizontal flue.

If either an additional 45° or 90° accessory elbow is used then the maximum permissible length of either pipe must be reduced by 3.0 ft or 5.4 ft respectively. The sum of the lengths of the two horizontal part must be less than 49.2 ft.

Installation:

- Drill holes B & C (on the wall template) through the outside wall that is less than 18" thick.
- Cut the pipes as necessary so that no more than 6" of intake pipe protrudes from the house and the exhaust pipe is a minimum of 4 inches longer than the intake pipe.
- Slide the Intake and exhaust pipes through the respective holes.
- Slide one rubber wall trim piece on each pipe from inside and one from outside.
- Attach each collar to the boiler with the gasket and screws provided.
- Insert each elbow into its corresponding collar.
- Connect each pipe to its corresponding elbow (as shown in the diagram).
- Secure end cap on the intake and exhaust pipe outside the house

9. Venting Cont.

C Alternative separate kit (Exhaust outside & intake inside)

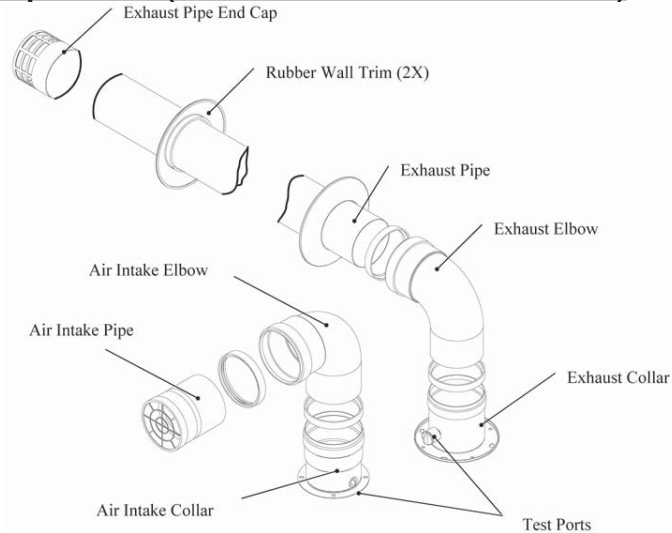

Figure 9.5 (Twin Pipe Ø 3.25 in)

This configuration of the twin pipe kit allows to discharge the exhaust gasses outside. The air supply is obtained with an air intake pipe. This allows to take air from the room where the boiler is installed.

If either an additional 45° or 90° accessory elbow is used then the maximum permissible length of either pipe must be reduced by 3.0 ft or 5.4 ft respectively.

Note: When utilizing this option, see page 14 for room ventilation details.

Installation:

- Drill hole C (on the wall template) through the outside wall that is less than 18" thick.
- Cut the pipe as necessary so that no more than 6" protrudes from the house.
- Slide the exhaust pipe through the hole.
- Slide one rubber wall trim piece on the pipe from inside and one from outside.
- Attach each collar to the boiler with the gasket and screws provided.
- Insert each elbow into its corresponding collar.
- Connect each pipe to its corresponding elbow.

9. Venting Cont.

D Alternative separate kit (Exhaust outside & intake inside)

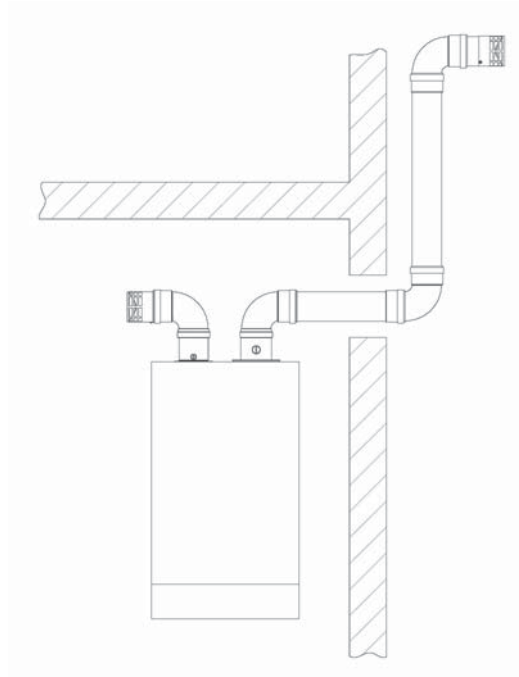

Figure 9.6 (Twin Pipe Ø 3.25 in)

This configuration of the twin pipe kit allows to discharge the exhaust gasses outside. The air supply is obtained with an air intake pipe. This allows to take air from the room where the boiler is installed.

If either an additional 45° or 90° accessory elbow is used then the maximum permissible length of either pipe must be reduced by 3.0 ft or 5.4 ft respectively.

Note: When utilizing this option, see page 14 for room ventilation details.

Installation:

- Drill hole C (on the wall template) through the outside wall Drill hole C (on the wall template) through the outside wall that is less than 18" thick.
- Cut the pipe as necessary so that no more than 6" protrudes from the house.
- Slide the exhaust pipe through the hole.
- Slide one rubber wall trim piece on the pipe from inside and one from outside.
- Attach each collar to the boiler with the gasket and screws provided.
- Insert each elbow into its corresponding collar.
- Connect each pipe to its corresponding elbow.

9. Venting Cont.

E Alternative separate kit (Exhaust & intake outside)

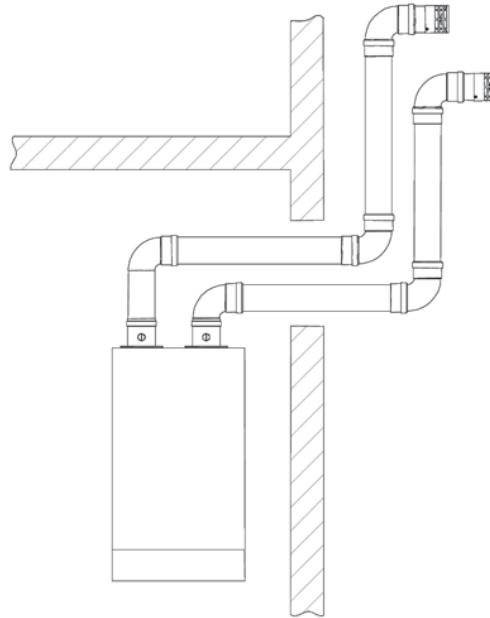

Figure 9.7 (Twin Pipe Ø 3.25 in)

These kits allow for separation of the air supply pipe from the pipe that discharges the exhaust gasses. Consequently it is possible to extend the flue system to a greater distance than that provided by the standard coaxial horizontal flue.

If either an additional 45° or 90° accessory elbow is used then the maximum permissible length of either pipe must be reduced by 3.0 ft or 5.4 ft respectively. The sum of the lengths of the two horizontal part must be less than 49. ft.

Installation:

- Drill holes B & C (on the wall template) through the outside wall Drill hole C (on the wall template) through the outside wall that is less than 18" thick.
- Cut the pipes as necessary so that no more than 6" of intake pipe protrudes from the house and the exhaust pipe is a minimum of 4 inches longer than the intake pipe.
- Slide the Intake and exhaust pipes through the respective holes.
- Slide one rubber wall trim piece on each pipe from inside and one from outside.
- Attach each collar to the boiler with the gasket and screws provided.
- Insert each elbow into its corresponding collar.
- Connect each pipe to its corresponding elbow (as shown in the diagram).
- Secure end cap on the intake and exhaust pipe outside the house.

9. Venting Cont.

F Standard Vertical-roof kit (Exhaust & intake outside)

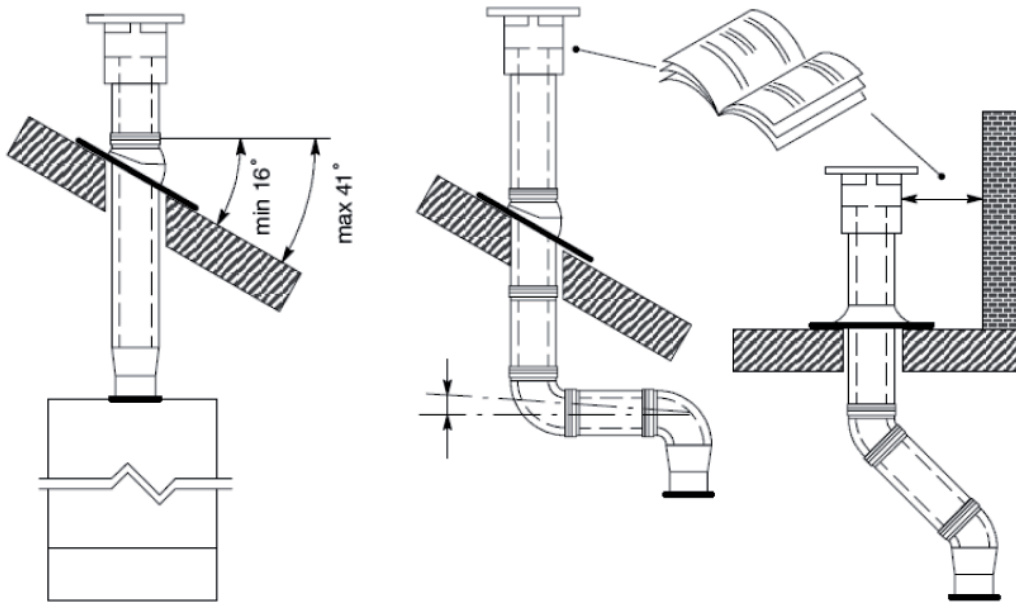

Figure 9.8 (vertical pipe \varnothing 3.1 / \varnothing 4.9 in)

This kit allows vertical termination of the flue pipe through the roof. The kit is 1.2 min length. Extension pieces (Co-axial) are also available which allows the flue system to be extended to a total overall maximum permissible length.

Optional 45° and 90° elbows can be used to offset the flue route.

Each additional elbow reduces the overall acceptable length of the flue system as follows:

45° reduce length by 1.6 ft.

90° reduce length by 3.2 ft.

Installation:

- Drill hole through the outside roof.
- Cut the pipe as necessary.
- Slide the intake and exhaust pipes through the hole.
- Slide one rubber wall trim piece on the pipe from inside and one from outside.
- Connect exhaust (inner) pipe to concentric elbow.
- Connect intake (outer) pipe to concentric elbow.
- Secure elbow to boiler using gasket and four screws provided.
- Secure end cap on the intake pipe outside the house.

10. Pipe Connections

copper pipe (C,D in figure 10.1), 2 - 1/2" (F,G in figure 10.1) located in a plastic bag in the boiler package.

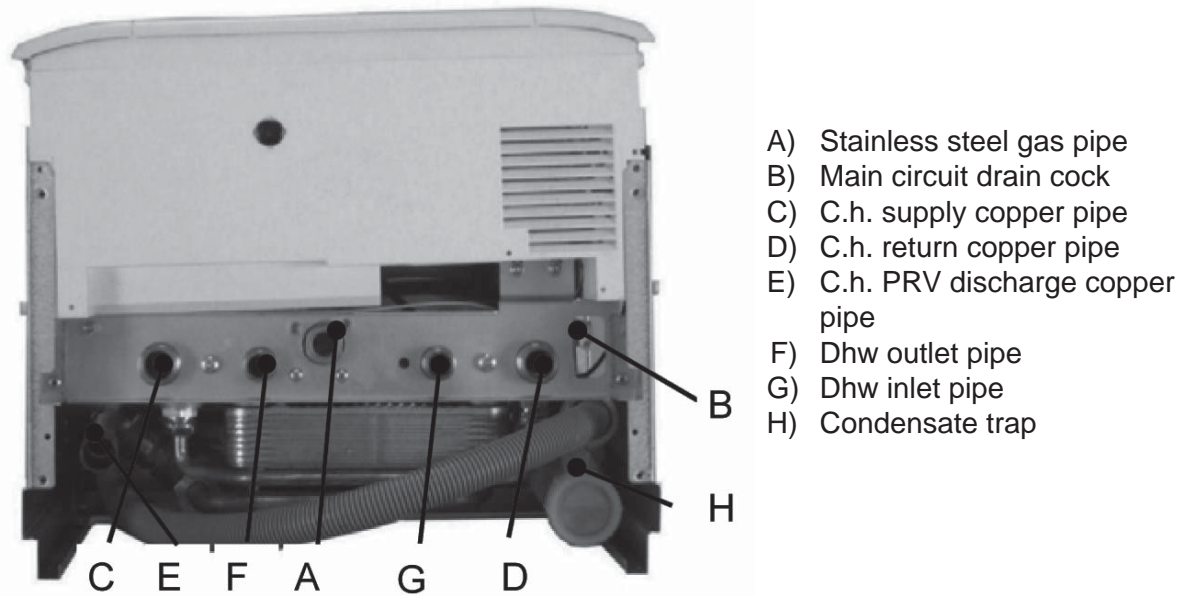

Figure 10.1

Installation:

- Remove the protective caps off boiler connections (Figure 10.1).
- Thoroughly clean the connections.
- Attach the supplied components to the boiler connections (see Figures 10.1). Be sure to use the proper gaskets for the pipe connections.
- Attach the condensate trap to an appropriate drain pipe.
- Before connecting the boiler to the heating system piping, review the suggested piping diagrams in Section 4 (page 11).
- If the c.h. system is above the boiler level, it is advisable to install c.h. cocks close to the boiler for servicing operation

Condensate trap:

The condensate trap allows the discharge of the condensate via the condensate drain pipe avoiding in the mean timethe escape of combustion products. A plastic ball closes the trap outlet in case that the trap is empty. The condensate trap is provided with two electrodes: if the drain pipe is plugged or in any case in which the condensate isn't correctly evacuated, the condensate level in the trap rises putting in contact the electrodes thus causing the boiler lock-out.

11. Gas Pipe Connections

Gas supply piping is to be sized and installed properly in order to provide a supply of gas sufficient to meet the maximum demand without undue loss of pressure between the meter and the boiler. Consult with the **National Fuel Gas Code ANSI Z223.1** for proper sizing of gas piping for various lengths and diameters.

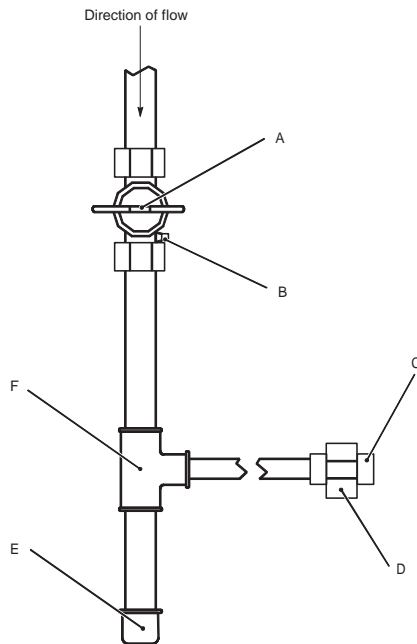

- A) Manual T-handle Shutoff Valve
- B) Pressure Gauge Port
- C) Flexible Gas Line to Burner
- D) Male Union $\frac{3}{4}$ " NPT
- E) Pipe Cap
- F) 1" X 1" X $\frac{3}{4}$ " TEE

Note: Height of valve above ground level to conform to local codes, if any. Massachusetts statecode requires gas shut off to be a tee handled gas cock.

Figure 11.1

Locate a drop pipe adjacent to, but not in front of the boiler. Locate a tee (F) in the drop pipe at the same elevation as the gas inlet connection to the boiler. Extend the drop line with a nipple towards the floor and cap to form a sediment trap (E). Install a shut off valve (A) before the tee with sediment trap and a union after the tee before the combination gas valve (D).

When installing the boiler, make sure a pipe compound resistant to the action of liquefied petroleum is used. Check piping for leaks. Always check leaks with a water and soap solution.

The boiler and its gas connection must be leak tested before placing the boiler in operation. The boiler and its individual shut-off valve must be disconnected from the gas supply piping system during any pressure testing of that system at test pressures in excess of $\frac{1}{2}$ psi (3.5 kPa).

WARNINGS

DO NOT USE A FLAME FOR CHECKING GAS LEAKS.

12. Electrical Connections/Wiring

12.1 Power Connection:

Removing Side Panel:

- Remove screws B

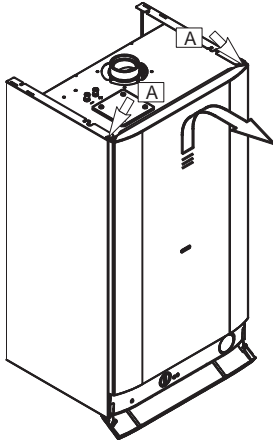

Figure 12.1

Removing Front Panel:

- Remove the front panel by removing screws A and sliding the front panel up and away from the boiler

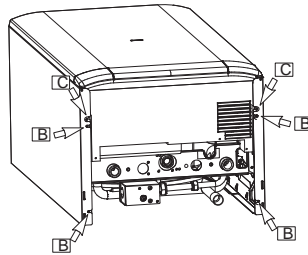

Figure 12.2

Removing Service Panel:

- Remove screws C.

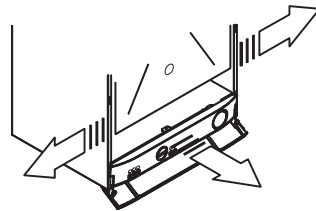

Figure 12.3

- Move the lower part of the side panels (figure 12.3).
- Pull the control panel. When completely pulled out, the panel can rotate 45° downward.

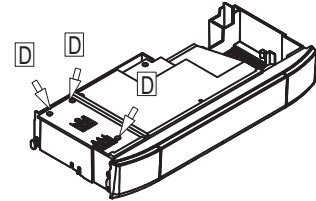

Figure 12.4

- Loosen screws D and remove the service panel (Fig. 12.4)

For the electrical connection to the boiler use electric wires which conform to local regulations. The boiler, when installed, must be electrically bonded to ground in accordance with the requirements of the authority having jurisdiction or, in the absence of such requirements, with the National Electrical Code, ANSI/NFPA 70 and/or Canadian Electrical Code Part I CSA C22.1, Electrical Code.

12.2 Connection to the electricity supply:

- Connect the electrical supply cable coming from the fused spur isolation switch to the power supply terminal block of the boiler (as shown in figure 12.5) keeping the same connections for the live wire and the neutral wire.

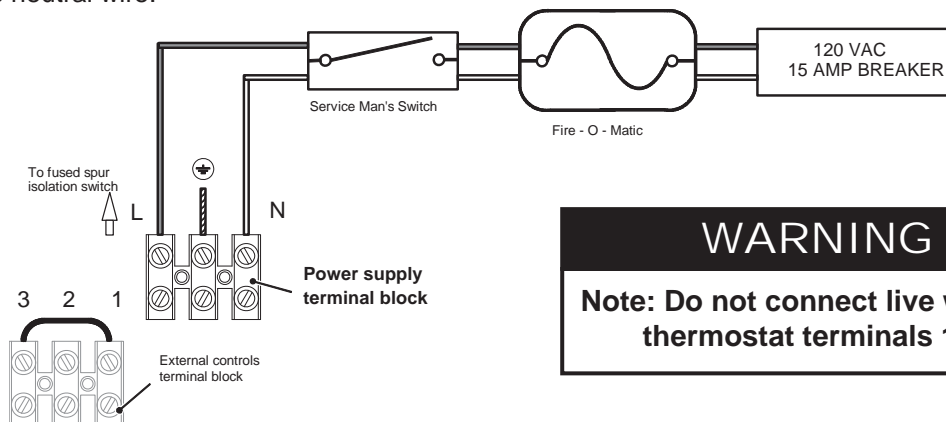

WARNING

Note: Do not connect live wires to thermostat terminals 1-3.

Figure 12.5

12. Electrical Connections/Wiring Cont.

12.3 Room Thermostat Connection:

- The room thermostat must be connected to the terminal block situated next to the control panel.

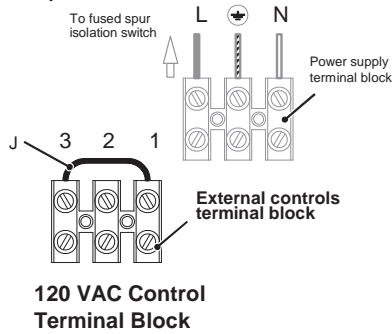

Figure 12.6

- Any external controls and connection lines must be rated at 120 VAC but under no circumstances should external live voltage be connected to the room thermostat link on the boiler.

- When connecting any type of external control, the jumper J in Fig. 12.6 must be removed.
- The room thermostat must be connected to the “Control Terminal Block” (Fig 12.7).

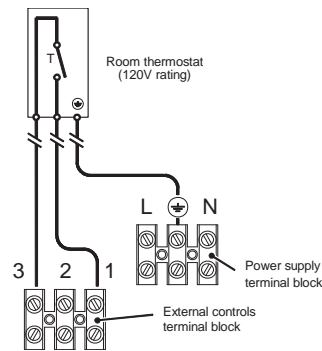

Figure 12.7

- Connect the room thermostat between terminals 1 and 3 as shown in Fig. 12.7.

12.4 Relay Panel Connection:

- The relay control must be connected to the terminal block situated next to the control panel.

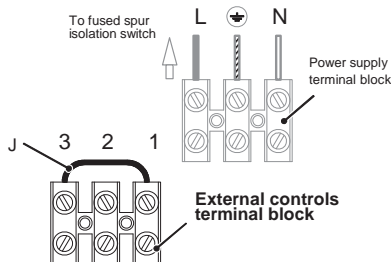

Figure 12.8

- When connecting any type of relay control, the jumper J in Fig. 12.8 must be removed.

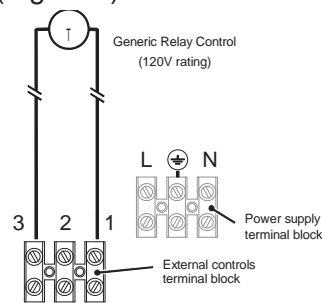

Figure 12.9

- Connect the dry contact switch to terminals 1 and 3 shown in Fig. 12.9.

12. Electrical Connections/Wiring Cont.

12.5 Zone Valve Micro Switch Connection:

- The zone valve micro switch must be connected to the terminal block situated next to the control panel.

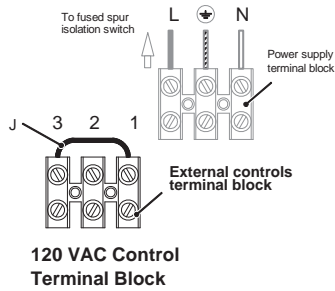

Figure 12.10

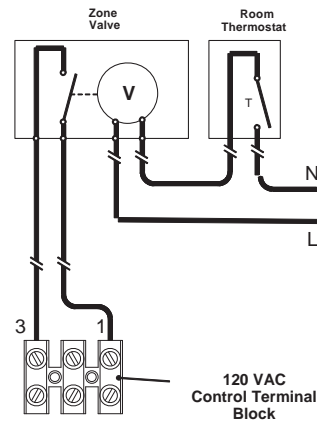

Figure 12.11

- When connecting the zone valve switch, the jumper J in Fig. 12.10 must be removed.
- Connect the micro switch of the zone valve to terminals 1 and 3 as shown in figure 12.11
- Connect the zone valve switch to the room thermostat as shown in figure 12.11

12.6 Finishing

- Route the electrical supply cord and the external control cord as illustrated in Fig. 12.12.

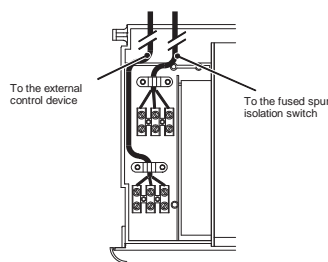

Figure 12.12

- Lock the cords in place with the flexible cord clamps.
- Replace the control panel reversing the steps on page 23.

13. Circulator Sizing

13.1 Circulator capacity as a function of flow rate:

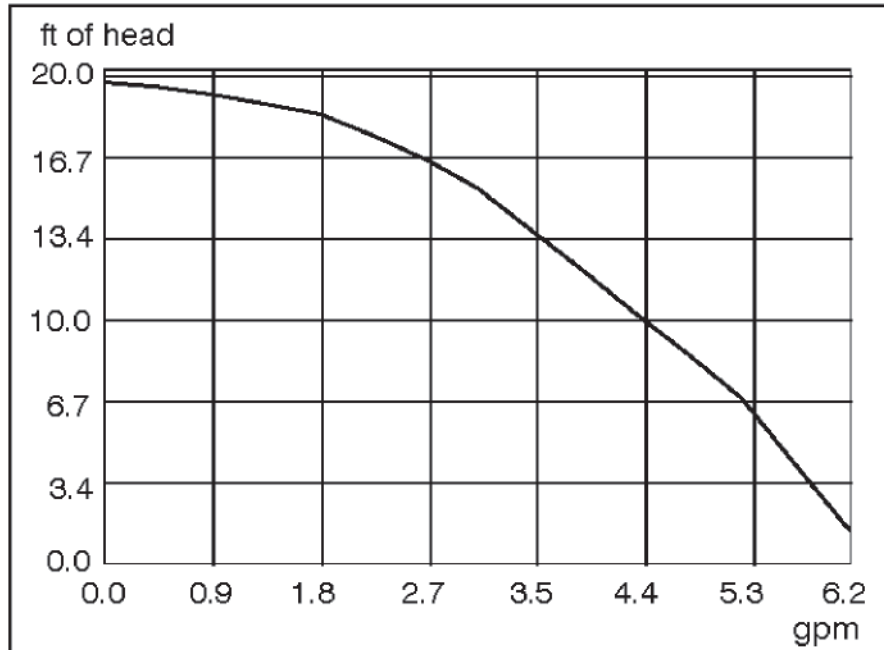

Figure 13.1

The hydraulic specification in Fig 13.1 represent the pressure (available head for the central heating system) as a function of the flow rate. The pressure loss due to the internal piping in the boiler has already been subtracted.

When determining proper piping of the heating system, verify that the internal boiler circulator will overcome the head loss of the system at the designed flow rate using the graph above.

If the internal circulator is **adequate**, direct system piping can be utilized. See section 4 page 12 for suggested direct supply/return piping.

If the internal circulator is **inadequate**, a secondary circulator must be utilized. See sections 14 for suggested primary/secondary piping.

13.2 Expansion vessels:

The height difference between the C.h. PRV (19 on page 11) and the highest point in the system may be 23 ft at most. For greater differences, increase the pre-load pressure in the C.h. expansion vessel (17 on page 11) and the system when cold, by 0.1 bar for additional 3.3 ft. For systems with volumes greater than 154l, an additional expansion vessel must be provided.

14. Piping

All external piping components are to be supplied by the installer. It is very important to use a Primary Secondary piping scheme when an external circulator will be used. Also, when the boiler is piped in a primary secondary manner, it is necessary to use the central heating flow restrictor supplied with the boiler. The flow restrictor ensures that there will be enough back pressure to make the central heating flow switch in a low head loss piping system like primary secondary.

Installation of flow restrictor: The flow restrictor is installed inside the pipe tail that attaches to the boiler. Place the flow restrictor into the gasket for the central heating supply pipe tail. Place the gasket on the pipe tail so the flow restrictor seats into the pipe tail. Then install the pipe tail onto the boiler.



There are two methods for accomplishing a Primary Secondary piping system. The first is to use two closely spaced tees for the boiler supply and return. An example is shown below in Figure 14.1. The run legs should be sized so that there is no excessive head loss on the external circulator that is installed. In most circumstances 1 1/4" piping will be the best choice. When the boiler is piped in this way, the external circulator will not have any hydraulic effect on the Riva Plus Combi. This is essential to ensure that the flow switch will operate properly.

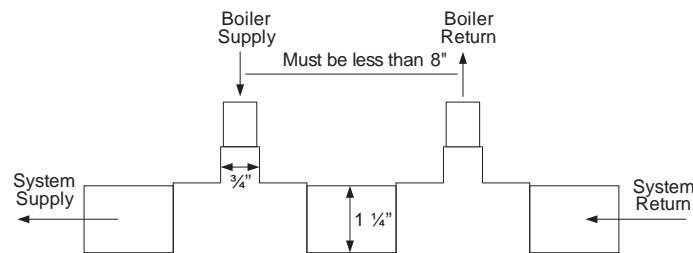

Figure 14.1

The second method is a hydraulic separator. Hydraulic separators are available commercially; however you can also construct your own. An example of a hydraulic separator is given in Figure 14.2. It is important that the separator be at least 2" in size to ensure proper performance.

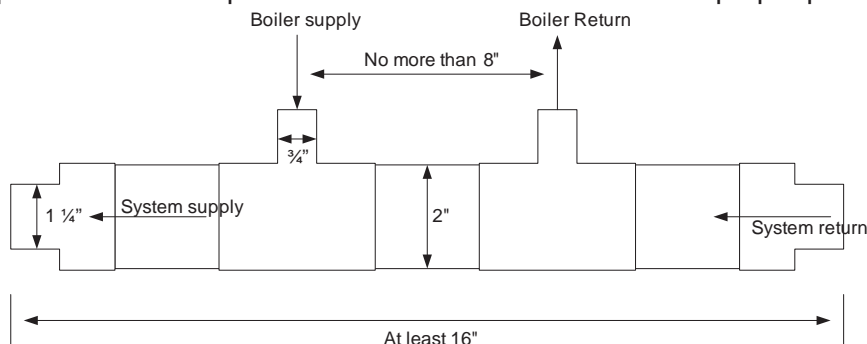

Figure 14.2

14. Piping Cont.

14.1 Primary – Secondary Piping:

All external piping components are to be supplied by the installer.
It is very important to use a hydraulic separator before secondary circulators.
All external piping components are to be supplied by the installer.
It is very important to use a hydraulic separator before secondary circulators.

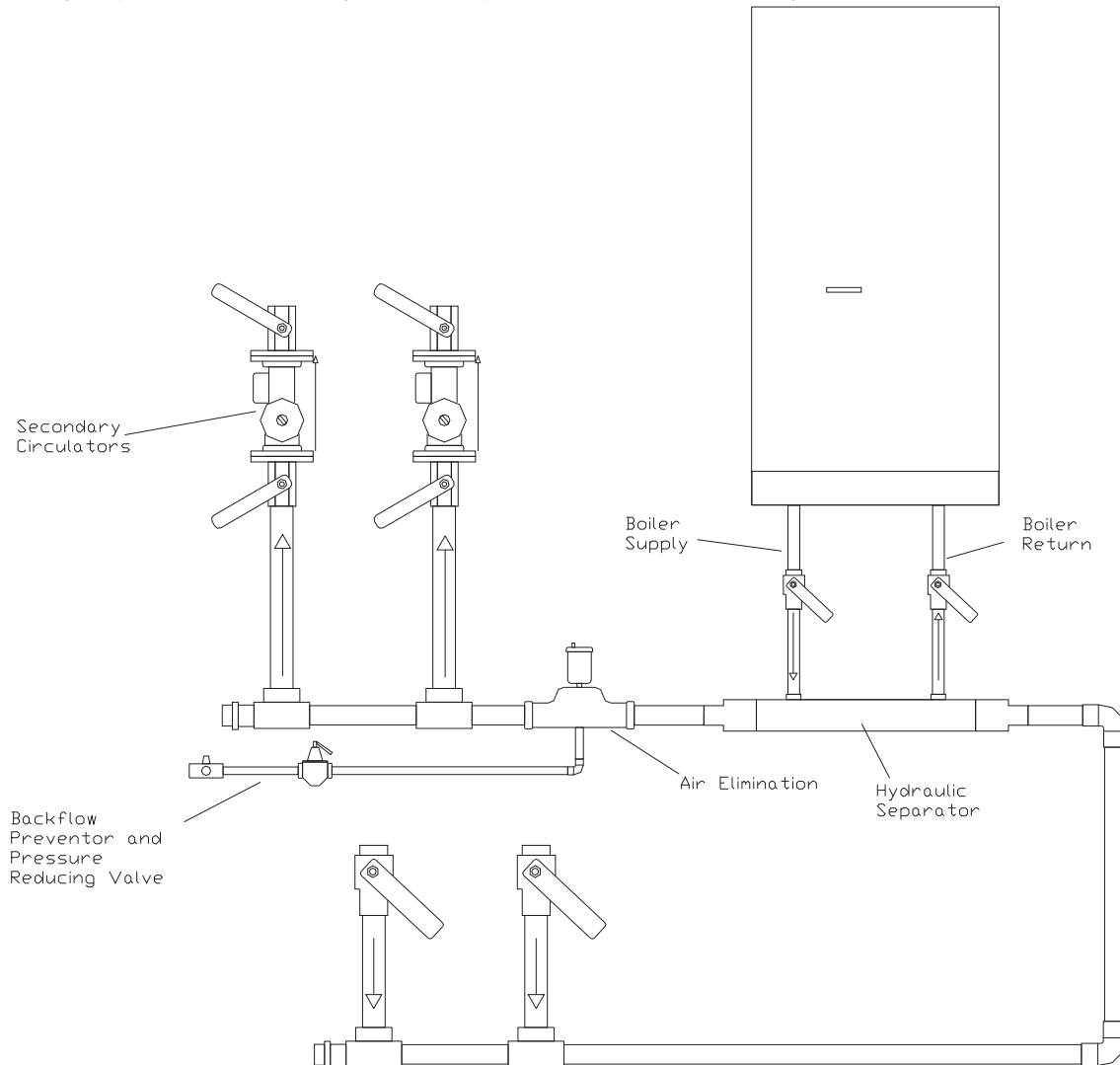

Figure 14.3

14. Piping Cont.

14.2 Primary – Secondary Piping with Zone Valves:

All external piping components are to be supplied by the installer.

It is very important to use a hydraulic separator before secondary circulators.

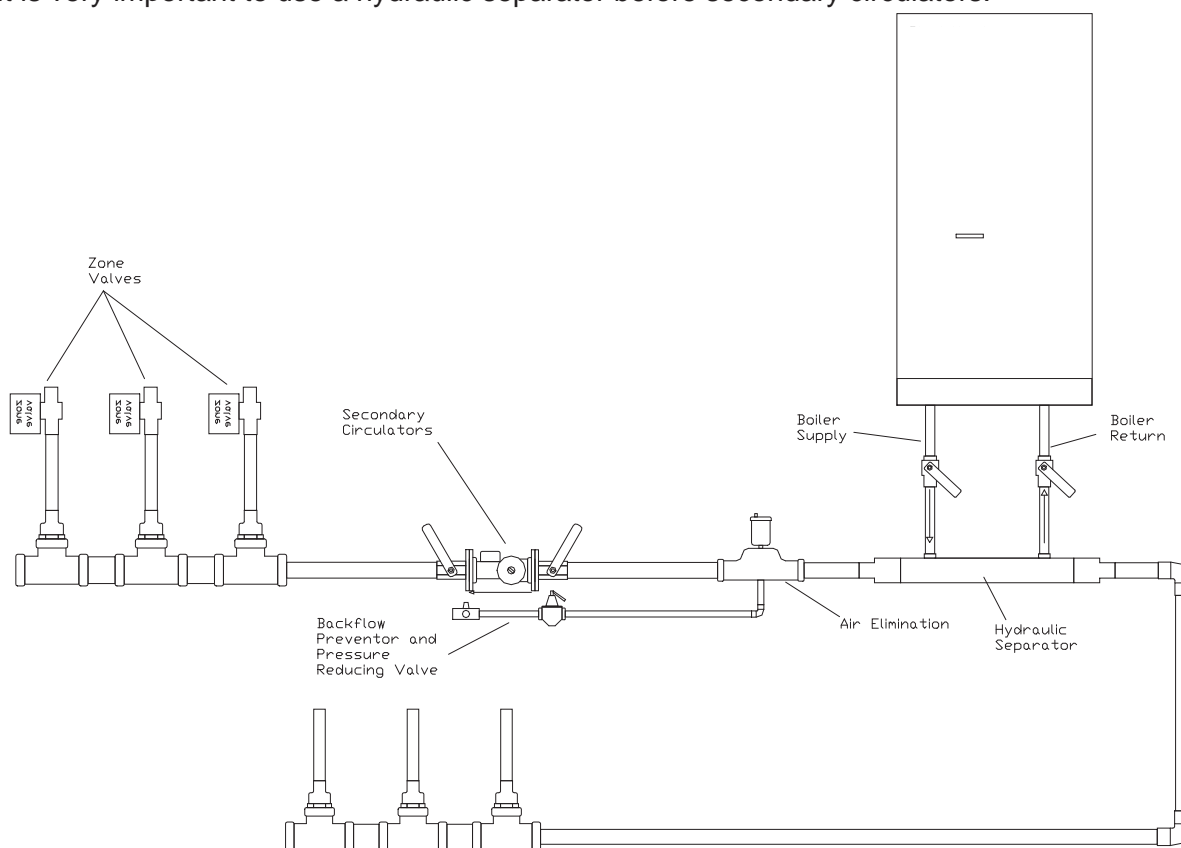

Figure 14.4

14. Piping Cont.

14.3 Manifold Piping with Zone Valves (shown conn. to radiators):

All external piping components are to be supplied by the installer.

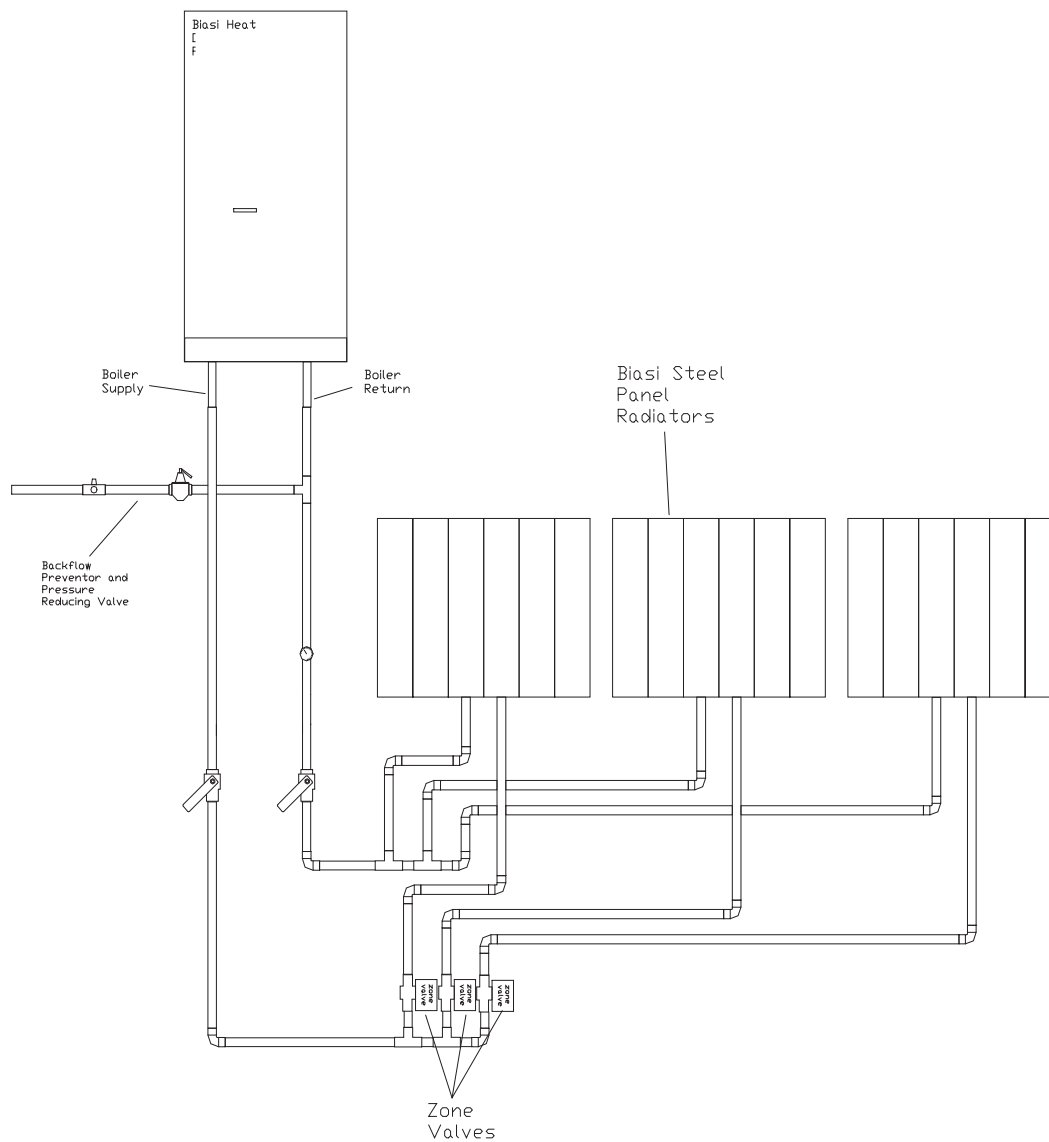

Figure 14.5

15. Commissioning

15.1 Initial filling of the system:

- Remove the front panel of the case.
- Unscrew the cap on the automatic air purger valve 3 (Fig 15.1) one full turn and leave open permanently.

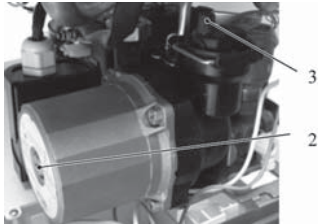

Figure 15.1

- Open the installer supplied automatic fill valve between the cold water inlet and Central Heating System (See 28 on piping diagrams in previous section).
- Open each radiator air vent starting at the lower point and close it only when clear water, free of bubbles, flows out.
- Purge the air from the pump by unscrewing the pump plug 2 (Fig. 15.2); release the pump by turning the rotor in the direction indicated by the arrow on the information plate.

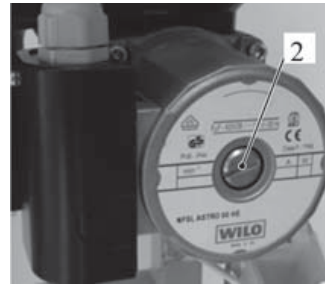

Figure 15.2

- Close the pump plug.
- Continue filling the system. The actual reading should ideally be 1.3 bar (19 psi) and not less than 0.3 bar (4.3 psi).
- Close all air release valves on the c.h. system.
- Inspect the boiler and the system for water soundness and remedy any leaks discovered.
- Cold flush the system to remove any loose particles and any system debris before starting the boiler for the first time.
- Reassemble the front panel of the case.
- Return fill valve to automatic position.

15.2 Lighting the boiler:

Note: If external controls are fitted (e.g. room thermostat) ensure they “call for heat”.

WARNINGS

THE BOILER AND ITS GAS CONNECTION MUST BE LEAK TESTED BEFORE THE BOILER IS PLACED IN OPERATION

- Turn on the electricity supply to the boiler, switching on the circuit breaker switch. The appliance operation light A will flash every 4 seconds.
- Turn the function selector B as in Fig. 15.3. The appliance operation light A will flash every 2 seconds.

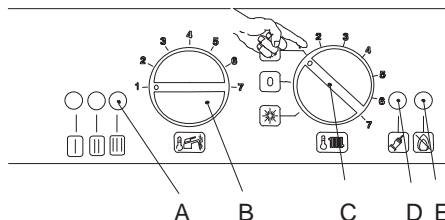

Figure 15.3

15. Commissioning Cont.

The boiler will now go through an ignition sequence and the burner will light.

If during the ignition attempt period the boiler fails to light, the full sequence control p.c.b. will go to lockout and the lock-out signal lamp E will appear.

To reset the boiler turn the knob C (figure 15.3) on the 0 position and then press and release the boiler reset button D (Fig. 15.3).

15.3 Checking the gas pressure at the burner:

This boiler has been tested to the highest quality control standards.

The maximum and minimum gas pressures are already set during this quality control process however the checking procedure must be followed to ensure maximum operating efficiency from the boiler.

- Remove the front panel of the case.
- Take off the lid of the sealed chamber.
- Loosen the internal screw 15 (Figure 15.4) on the Outlet Pressure Test Point of the Gas Valve and connect a pressure gauge using a suitable hose.

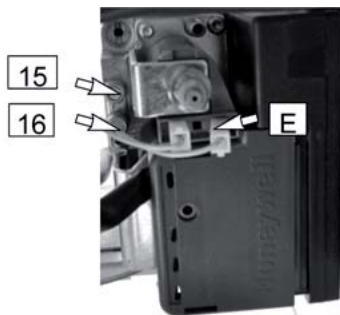

Figure 15.4

- Set the c.h. temperature control knob to its maximum position. If external controls are fitted (e.g. room thermostat) ensure they “call for heat”.
- Switch on the boiler.
- Check the maximum gas pressure and compare the value on the gauge with the value indicated in the Section 2 on page 10 (gas pressures at the burner).
- Check the maximum gas flow at the gas meter and compare the value indicated in the section 2 on page 10 (gas flow rate).

- Switch off the boiler.
- Disconnect the gas modulator coil by removing the electrical connector E (Figure 15.4).
- Switch on the boiler.
- Check the minimum gas pressure and compare the value on the gauge with the value indicated in the Section 2 on page 10 (gas pressures at the burner).
- Switch off the boiler and re-connect the electrical connector E to the modulator coil.
- Switch on the boiler.
- Check that the boiler lights up uniformly.
- Switch off the boiler, turn off the hot water taps and disconnect the pressure gauge.
- Close the lid of the sealed chamber.

Important: after the checks all of the test points must be sealed.

15. Commissioning Cont.

15.4 Adjustment of the gas pressure:

- Remove the front panel of the case.
- Take off the lid of the sealed chamber.
- Open the gas valve inlet pressure test point (16 in Fig. 15.5) at the valve input, connect a suitable pressure gauge and check the gas pressure of the supply network.
- Remove the gauge and close the pressure test point 16.
- Open the gas valve outlet pressure test point (15 in Fig. 15.5) and connect the gauge.

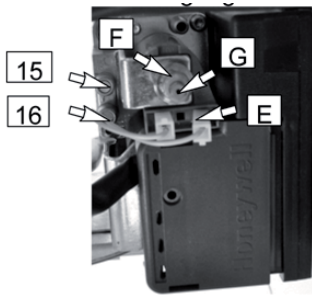

Figure 15.5

- Remove the protection cap I (Fig. 15.7) from the mechanical pressure adjustment components levering with a flat screwdriver in the slots H.
- Start the boiler at its maximum power.

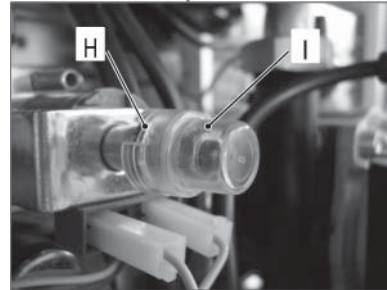

Figure 15.6

- Ensure that the boiler is not range rated.
- Rotate the maximum gas pressure adjustment (F in Fig. 15.5) until you obtain the required pressure (by rotating clockwise the pressure increases).
- Turn the boiler off and disconnect one of the two connectors (E in Fig. 15.5).
- Start the boiler and rotate the minimum gas pressure adjustment (G in Fig. 15.5) until you obtain the required pressure (by rotating clockwise the pressure increases).
- Turn the boiler off and re-connect the wire to the modulating operator.
- Start the boiler and check again the maximum gas pressure setting.
- Turn the boiler off and disconnect the gauge.
- Close the lid of the sealed chamber.

Important: after the checks all of the test points must be sealed.

15.5 Checking the ignition device:

With the burner on high flame close the gas cock. After three ignition attempts (within about three minutes), the lock-out signal lamp must appear (D on Figure 15.3). To reset the boiler turn the knob B (figure 15.3) on the 0 position and then press and release the boiler reset button (C on Figure 15.3).

15. Commissioning Cont.

15.6 Checking the burner ignition:

- Turn the boiler OFF.
- Open the gas valve outlet pressure test point 15 (figure 15.5) and connect the gauge.
- Turn the boiler ON positioning the function selector B in the position shown in figure 15.7 and ensure that the room thermostat is set to “heat demand”.

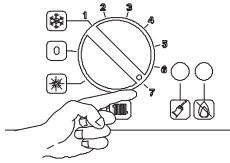

Figure 15.7

- Loosen screws D and remove the service panel (figure 15.8).

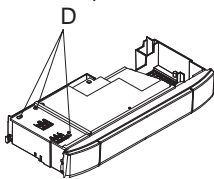

Figure 15.8

- Watch the gauge and check to see if the ignition pressure registered corresponds to the values given in the Technical Data. Turn off the boiler and reignite it by turning the function selector B to the 0 position and then back to that indicated in figure 15.7.
- Repeat this process two to three times

leaving 30 second intervals between each ignition. Check the ignition pressures and visually check that the burner lights uniformly and in a controlled manner.

- To carry out the adjustment move the function selector 3 to the OFF position (Fig. 15.9) and use the device (ACC).

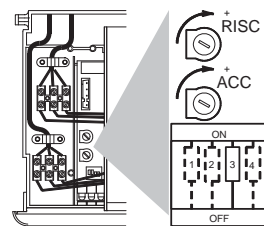

Figure 15.9

- Adjust the gas pressure at the injectors to the value indicated in the tables of section 2. By rotating the device clockwise the pressure increases.
- After the adjustment operations bring the selector 3 of figure 15.9 back to the normal position (ON).
- Reassemble the service panel.
- Close the gas valve outlet pressure test point 15 (figure 15.5).
- Reassemble the front panel of the case.

Important: after the checks all of the test points must be sealed.

15.7 Adjustment of the useful c.h. output:

- Turn the boiler OFF.
- Open the gas valve outlet pressure test point 15 (figure 15.5) and connect the gauge.
- Turn the boiler ON positioning the function selector B in the position shown in figure 15.7 and ensure that the room thermostat is set to “heat demand”.
- Loosen screws D and remove the service panel (figure 15.8).
- To carry out the adjustment use the adjustment device (RISC) with the help of a screwdriver.
- By rotating the device clockwise the pressure increases.
- Adjust the gas pressure at the burner to the value according to the useful c.h. output wanted (Tab. 15.1).
- Reassemble the service panel.
- Close the gas valve outlet pressure test point 15 (figure 15.5).
- Reassemble the front panel of the case.

15. Commissioning Cont.

15.8 Labels placement:

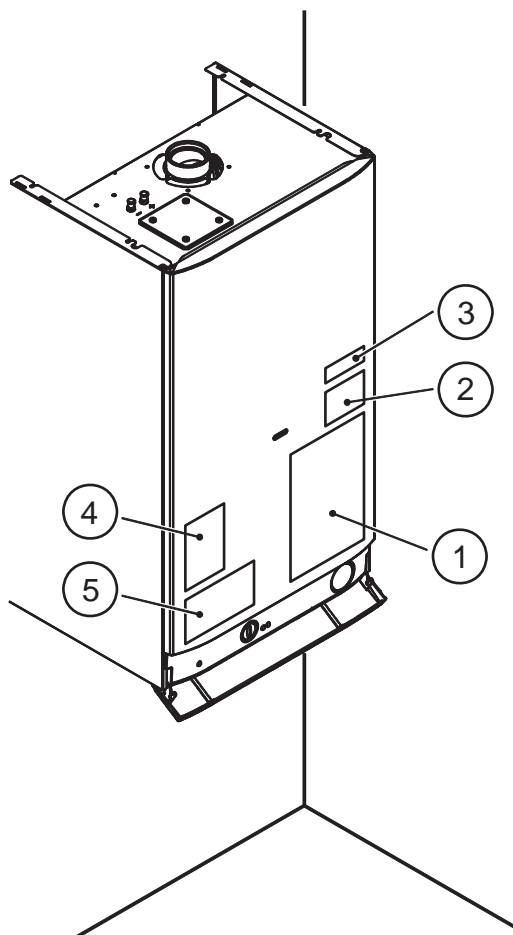

Figure 15.10

Warning: The installation is not complete unless labels supplied are placed on the boiler as shown in Figure 15.10.

All the labels supplied with the boiler are numbered for reference. According to Figure 15.10 place all the labels on the boiler. Use label numbered as 1 (already installed in the front panel) to begin the placement in the correct way.

15. Commissioning Cont.

15.9 Checking the flue system and combustion:

- The flue system should be visually checked for soundness. Check all clamps, gaskets and fixings are secure and tight.
- Ensure that the flue terminal is sited correctly in accordance with the flue fitting instructions.
- Reference tables are given in the Sections 2 on page 10 of this manual for proper CO₂ levels.

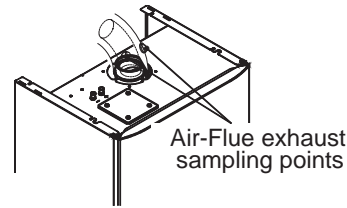

Figure 15.11

To check the exhaust gas:

- Remove the plugs indicated (Fig. 15.11).
- Insert the analyzer probe in the exhaust gas sampling point or in the air intake sampling point.

15.10 Instructing the user:

- Hand over the User manual, this Installation, Operation and Service manual to the end user and explain how to use the unit in Central Heating mode.
- Take the User step by step through the lighting instructions.
- Show the User how to switch off the appliance quickly and indicate the position of the electric service switch and the boiler on/off switch.
- Explain the proper use and adjustment of all system controls; this will ensure the greatest possible safety and fuel economy.
- Explain the function and use of the function switch.
- Explain how to turn off the appliance for both short and long periods and advise on the precautions necessary to prevent damage should the appliance be inoperative when freezing conditions may occur.
- Fill in the details required on the Boiler Guarantee Certificate and hand to the User advising them to return the correct section for boiler Guarantee registration. Finally, advise the User that, for continued safe and efficient operation, the appliance must be serviced by a competent person at least once a year.

Useful output	<i>KW</i>	16.7	18.9	21.1	23.2	25.4	27.5	29.6	31.8
	<i>BTU/h</i>	56983	64490	71996	79161	86668	93833	101000	108506
Naturel	Pa	290	370	460	560	660	780	900	1040
	inwc.	1.16	1.48	1.84	2.24	2.65	3.13	3.61	4.17
	m ³ /h	1.76	2.00	2.23	2.46	2.69	2.91	3.14	3.36
	ft ³ /h	5.77	6.56	7.31	8.07	8.82	9.54	10.30	11.02
Propane	Pa	680	860	1060	1270	1500	1740	2000	2270
	inwc.	1.45	1.69	2.25	3.21	4.34	5.62	7.06	8.95
	Kg/h	1.3	1.5	1.7	1.9	2.0	2.2	2.3	2.5
	lb/h	3.0	3.3	3.7	4.1	4.4	4.8	5.1	5.5

Table 15.1

16. Gas Conversion

WARNINGS: Procedures to adapt the boiler to the type of gas available must be carried out by a competent and responsible person. Components used to adapt it to the type of gas available must be genuine parts only.

Procedures:

- Check that the gas cock (30 on Section 4) fitted on the gas supply pipe is turned off and the appliance is switched off at the circuit breaker.
- Remove the front and side panels of the case (see the section 17.2 Annual Maintenance – Dismantling the External Panels).
- Take off the lid of the sealed chamber.
- Remove the front panel of the combustion chamber.

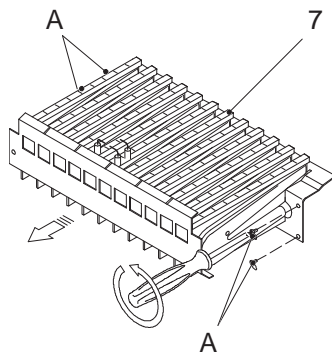

Figure 16.1

- Loosen the screws A and remove the burner 7 (Figure 16.1).
- Carry out the conversion for the type of gas, replacing the burner injectors correctly.
- Re-assemble the burner, the front panel of the combustion chamber and the lid of the sealed chamber.
- Extract the control panel as explained in the section 12.1 of this manual.
- Loosen the screws D and remove the service panel (figure 16.2)

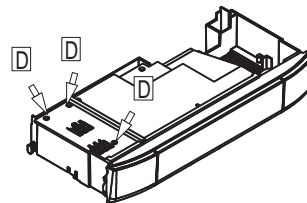

Figure 16.2

- Set correctly the dip-switch “2” to the correct position (Fig. 16.3) in accordance with the following table.

Gas supply	Position of the switch 2
Natural gas	On
L.P.G.	Off

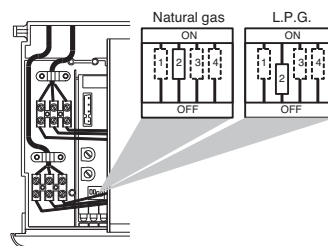

Figure 16.3

- Close the service panel.
- Turn on the boiler.
- Calibrate the gas valve according to the instructions given in section 15.4 of this manual.
- Set the correct gas pressure for central heating output required.
- Stick on the inside of the left hand side panel adjacent to the data badge the self-adhesive label (included with the conversion kit) indicating the type of gas, and the gas pressures to which the appliance has been set.
- Reassemble the front and side panels of the case.

17. Annual Maintenance

17.1 Warnings:

The procedures detailed in this chapter must be carried out only by a professionally qualified person. Thus you are advised to contact an Authorised Service Agent.

For efficient and continuous operation of the boiler you are advised to have, at least once a year, maintenance and cleaning done by an Approved Service Person.

Isolate the appliance from the electricity supply by turning off the fused spur isolation switch adjacent to the appliance and turn off the gas cock, before carrying out any procedures, whatsoever, for cleaning, maintenance, opening or dismantling boiler panels.

17.2 Dismanteling the external panels:

Front Panel:

- Loosen the three screws A (Fig. 17.1)
- Lift and remove the panel.

Side Panels:

- Loosen the screws B (Figure 17.2). Bring the bottom of the panels away from the boiler and lift them, freeing them from the top hooks.
- Take off the front panel of the case, then the sealed chamber lid and the front panel of the combustion chamber. If you notice dirt on the fins of the primary heat exchanger (9 on page 10), cover the sloping surfaces of the burner (7 on page 10) entirely in a protective layer (sheets of newspaper or similar). Brush out the primary heat exchanger (9 on page 10) with a bristle paintbrush.

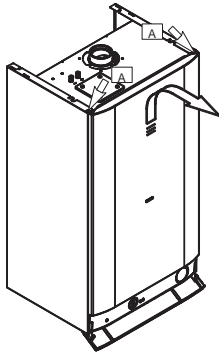

Figure 17.1

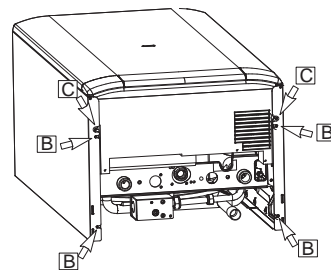

Figure 17.2

17.3 Emptying the d.h.w. system:

- Close the pressure reducing automatic fill valve (28 on Section 4)
- Open the central heating drain cock (F in Fig. 17.3).
- Empty the c.h. system.
- Close the central heating drain cock (F in Fig. 17.3).
- Open the pressure reducing automatic fill valve (28 on Section 4)

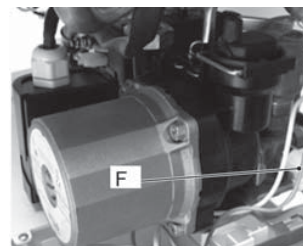

Figure 17.3

17. Annual Maintenance Cont.

17.4 Emptying the Domestic Hot Water circuit

- Close the inlet valve
- Open the system domestic hot water valves

17.5 Cleaning the primary heat exchanger:

Follow the instructions for removing the external panels from 17.2. Remove the nine screws labelled C in figure 17.4. Now you will have complete access to the combustion chamber. The sloping and multi-gas type burner (7 on page 11) does not need special maintenance, but it is sufficient to dust it with a bristle paintbrush.

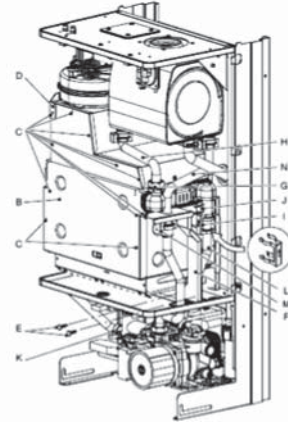

Figure 17.4

17.6 Checking the combustion fan:

The combustion fan does not require any special maintenance. Lubrication is not necessary due to the fact that the ball bearings are sealed. Check that the fan operates and that the visible impeller fins are free of any dirt or obstructions.

17.7 Checking the flue:

Have the integrity of the flue outlet pipe (24 on page 11) air intake pipe (25 on page 11), checked periodically, the venturi device (23 on page 11) cleaned and the efficiency of the flue safety circuit checked at least once a year. For all the above maintenance operations it is advisable to call an approved Service Engineer.

- Remove the four Phillips head screws from the vent connector on the boiler.
- Remove the vent connector from the boiler by pulling vertically on it.
- Remove the first elbow from the horizontal run of the exhaust to the outside.
- Using a flashlight inspect each length of vent pipe for obstructions and dirt buildup. Clean any that is found with an appropriate sized brush.
- Inspect the venture device inside the outlet of the combustion fan. Make sure that it is free of any dirt build up or blockage.
- Make sure the seals are properly seated in the female ends of the vent pipe with the fins facing the male end of the pipe.
- Reinstall the elbow onto the horizontal run of the pipe first by simply pushing the parts together.
- Push the vent adapter down onto the top of the boiler and reinstall the four Phillips head screws.

17. Annual Maintenance Cont.

17.8 Checking the pressurization in the expansion vessel:

Empty the central heating system as described in section 17.3 of this chapter and check that the pressure in the expansion vessel is not less than 1 bar (14.5 psi). See also section 13.2 of this manual. If the pressure should be lower, take steps to correct the pressure level. To check the pressure at the venturi device, use the test points (12 on page 11).

- Remove the caps of the pressure test points and connect a differential pressure gauge.
- Switch on the boiler
- Compare the value on the gauge with the minimum values of venturi pressure indicated in the Section 2 on page 9.

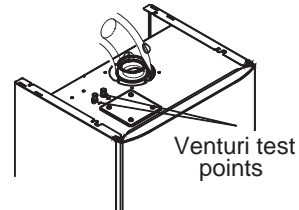

Figure 17.5

17.9 Visual inspection of appliance:

Visually inspect all water joints, seals and connections for any evidence of leakage and re-tighten, grease or replace them as necessary.

17.10 Gas pressures and soundness:

Check appliance for gas soundness. Recheck operational pressures and adjust as necessary as described in Section 15.4 page 37 of this manual.

17.11 Cleaning the primary heat exchanger:

- Take off the front panel of the case, then the sealed chamber lid and the front panel of the combustion chamber. If you notice dirt on the fins of the primary heat exchanger (9 on page 11), cover the sloping surfaces of the burner (7 on page 11) entirely in a protective layer (sheets of newspaper or similar). Brush out the primary heat exchanger (9 on page 11) with a bristle paintbrush.

17.12 Cleaning the domestic hot water exchanger:

The descaling of the domestic hot water exchanger will be evaluated by the Authorised Assistance Centre Technician, who will carry out any cleaning, using specific products.

17.13 Condensate trap:

To clean the condensate trap:

- Remove the front and right case panels.
- Disconnect the trap from the drain pipe.
- Using pliers, remove the spring D moving it upwards.
- Disconnect the wirings from the trap.
- Reassemble carrying out the removal operations in reverse order.

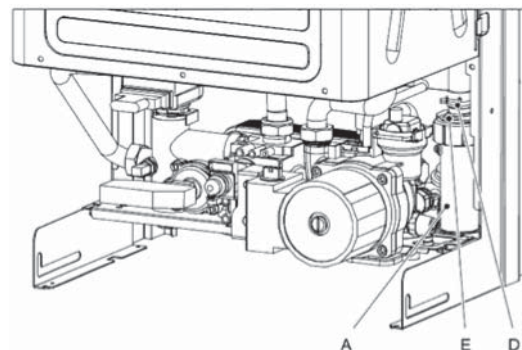

Figure 17.6

The trap should be serviced once a year during the annual service.

18. Vent Part Spares

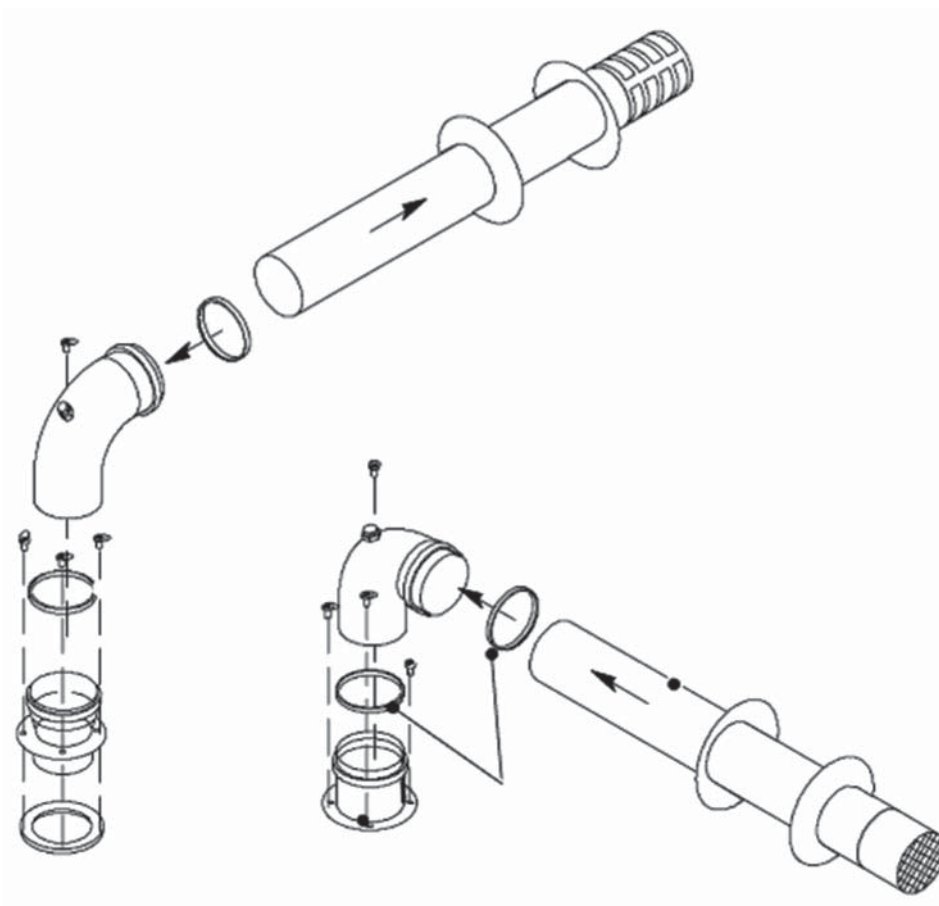

Figure 18.1

Description	Order Number
Twin pipe kit	10999.0393.0

18. Vent Part Cont.

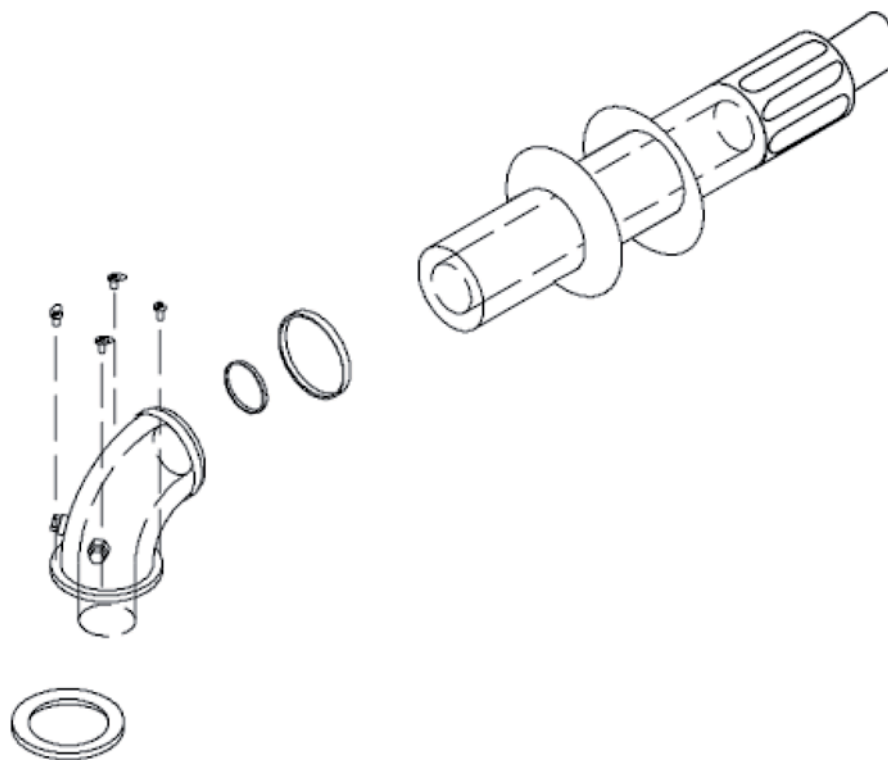

Figure 18.2

Description	Order Number
Coaxial flue kit	10999.0387.0

18. Vent Part Cont.

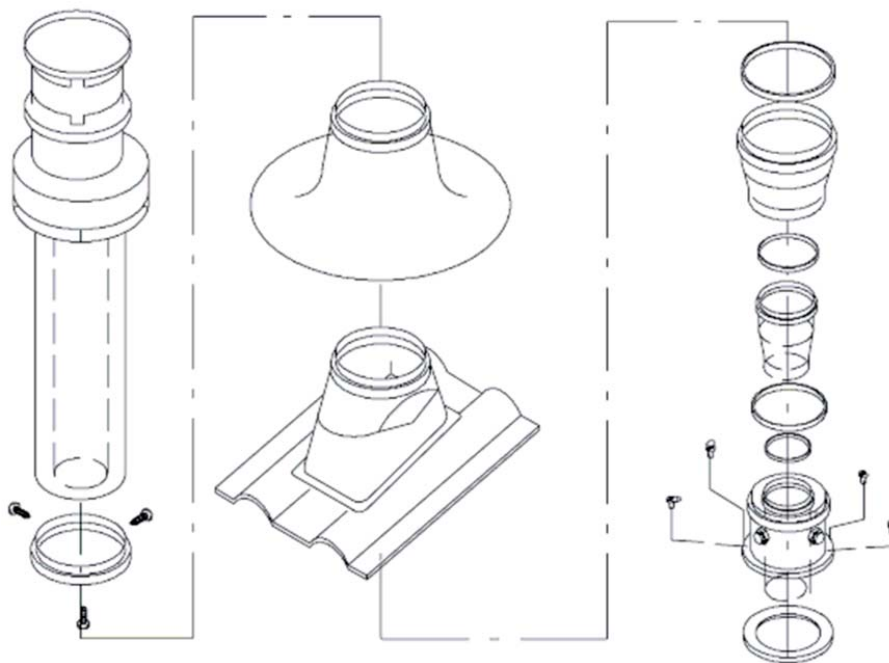

Figure 18.3

Part	Description	Order Number
A	Coaxial flue kit	10999.0387.0

For any spare parts, please contact QHT Inc. at 800-501-7697.

19. Installer Notes

System Checkout:

Boiler Model No. _____

Serial No. _____

Original Purchaser:

Installer:

Performance Tests:

GROSS STACK TEMPERATURE _____

ROOM TEMPERATURE (AMBIENT) _____

NET STACK TEMPERATURE _____

CO₂ _____

O₂ _____

SMOKE READING _____

COMBUSTION EFFICIENCY _____

COMMENTS _____



17962.1481.0 2508 (52A4)USA

