

# Owner's Manual

for **Polar Furnace®** Updraft Heater



**POLAR**  
**FURNACE**  
clean, simple heating with wood



**IMPORTANT: Read and fully understand this manual prior to installing and/or operating a Polar Furnace Heater.**

## **POLAR FURNACE UPDRAFT HEATER 25 YEAR LIMITED REPLACEMENT WARRANTY**

Polar Furnace Mfg. Inc. (The Company) warrants the heater identified herein to be free from defects in material and workmanship during normal use for a period of two years from the date of original purchase to the original purchaser of this heater. In year one and two The Company will cover the full cost of replacing or repairing the heater onsite or at our factories including materials, parts, travel and labour. Electric and electronic components are limited to a 12-month 100% replacement warranty. In years 3, 4 and 5 this warranty is limited to 80% of cost of repair at The Company's then current rates and is limited to the cost of labor, material and parts required for repair only. Only the manufacturer at address on this certificate will determine in its sole and absolute discretion all warranty issues, and work claimed under warranty must be approved in writing by The Company prior to any repairs being started.

If repair is not feasible for any reason as judged by The Company our obligations under this warranty are limited to providing a replacement heater per the following schedule. For the 25-year warranty period the following pro-rated replacement charge will apply.

Schedule of charges for replacement of the complete heater.

From 1 through 2 years	Company's then current list price less 100%
From 3 through 4 years	Company's then current list price less 90%
From 5 through 6 years	Company's then current list price less 65%
From 7 through 10 years	Company's then current list price less 35%
From 11 through to 25 years	Company's then current list price less 5%

All replacement heaters are FOB our factory unless otherwise specified in this warranty.  
The warranty period on any replacement heater is from the date of the sale of the original heater.

### General Conditions.

The warranty contained herein shall be voided if the heater is not installed and operated as instructed in the owner manual. The hand over checklist must be signed by the customer and dealer and submitted along with the warranty registration for this warranty to be valid. Heater must never be pressurized and pressurizing the heater voids this warranty. A properly qualified tradesperson/s should perform all installations. If chimney needs be extended an appropriately certified and approved insulated chimney must be used. Your dealer may charge you for a service call to do warranty work. Parts will be replaced on an even exchange basis. Polar Furnace updraft heaters are not intended to be the only source of heat. A backup system should be in place to prevent resultant damage due to a lack of heat. Door seals, light bulbs, fire tending tools, heat shields and any other wear items are not covered under this warranty. The insulated chimney is not covered under this warranty. High temperature refractory materials are warranted for 1 year under this warranty. In use, small cracks can occur in high temperature refractory and will not affect the performance of the heater. Damaged caused by abuse, accidents, improper use, improper installation, excess creosote buildup, overheating, freezing, corrosion, negligence, accidents in transit, and pressurization are not covered under this warranty. Damage resulting from modifications or alterations will not be covered under this warranty. If the serial number on the equipment is defaced, altered or removed this warranty is void. Damage caused by

burning flammable materials (such as petroleum products) or any other material besides properly prepared wood will void this warranty. This warranty is limited to defective parts repair and/or replacement only, and excludes any incidental and consequential damages. Only nontoxic antifreeze that meets and/or is approved per all applicable regulations and standards may be used. The Company will not be responsible for any environmental damages or charges resulting from use of toxic and or unapproved types of antifreeze. Antifreeze will breakdown over a period of time and therefore should be tested annually. Always dispose of antifreeze per federal, state, provincial, local or any applicable laws and regulations. Loss of antifreeze under any situation and condition is not covered under this warranty. The Company is not responsible for replacement of water, water treatment, antifreeze, removal, disposal, costs of transportation, or shipping charges. Warranty does not include any plumbing, boiler piping, valves, controls or any other component or system external to the boiler package. WARNING, The Company will not warranty the inside of the fire drum due to ash corrosion. Rotation of ashes and/or stirring of firebox corners must be performed as per the operator manual instructions and as displayed on the maintenance list located on the side of the heater. WARNING, The Company will not warranty the water jacket due to corrosion from corrosive or improperly treated water. An appropriate water treatment must be added and receipt retained for proof of use to establish any warranty claims. We will not be liable to any contingency beyond our control including war, strikes, floods, government restrictions or short supply of material. We will not be liable for any labor cost, except above schedule. This warranty replaces and supersedes any and all other warranties, expressed or implied, directly and or indirectly whether at law, common law, equity and/or statute and constitutes the only warranty of The Company and the only liability of The Company. This warranty constitutes the entire agreement between the parties with respect to the subject matter and supersedes all prior agreements, negotiations, discussions, undertakings, representations, warranties and understandings, whether written or verbal. This Warranty is governed by, and is to be construed and interpreted in accordance with the laws of Manitoba and the federal laws of Canada applicable in Manitoba. The purchaser and The Company each irrevocably agree to submit to the jurisdiction of the courts of Manitoba. The Company's limitation of liability pursuant to any warranty shall be equivalent in all respects to the sum of \$1.00.

## **WARRANTY VOID IF NOT REGISTERED**

**POLAR FURNACE MFG. INC.  
UPDRAFT HEATER**

**WARRANTY REGISTRATION FORM**

Customer's Name: \_\_\_\_\_

Dealership Name: \_\_\_\_\_

Address: \_\_\_\_\_

Address: \_\_\_\_\_

City, State/Prov. Code: \_\_\_\_\_

City, State/Prov. Code:: \_\_\_\_\_

Phone: (\_\_\_\_) \_\_\_\_\_

Serial No. \_\_\_\_\_

Date of Purchase: \_\_\_\_/\_\_\_\_/\_\_\_\_

**DELIVERY CHECKLIST**

- \_\_\_\_\_ Review owner's manual.
- \_\_\_\_\_ Describe installation methods and recommendations.
- \_\_\_\_\_ Review warranty and service requirements.
- \_\_\_\_\_ Identify safety hazards and demonstrate proper operation.
- \_\_\_\_\_ Explain required maintenance schedule.
- \_\_\_\_\_ Describe possible problems from using different types of wood.
- \_\_\_\_\_ No warranties are validated unless this form and registration are completed and returned.

**CUSTOMER ACCEPTANCE**

I have inspected the Polar Furnace heater with the customer and reviewed all items on the delivery checklist. I have thoroughly instructed the customer on the equipment identified herein and thoroughly reviewed the operator's manual. The customer has accepted responsibility for the operation and maintenance of the product identified herein.

Date: \_\_\_\_\_

Dealer's Rep. Signature: \_\_\_\_\_

The dealer rep. and I have inspected my new Polar Furnace heater and reviewed all items on the delivery checklist. The dealer rep. has reviewed the operator's manual with me and has thoroughly instructed me on the equipment herein. I assume full responsibility for the operation and maintenance of the product identified herein.

Date: \_\_\_\_\_

Owner's Signature: \_\_\_\_\_

A nominal fee may be charged for service calls. All sales are final. Heater approved for use with well-seasoned wood only. Suitability of use is the customer's decision. The customer is responsible for insuring conformance to local bylaws and regulations. A backup heating system is strongly recommended.

White—Polar Furnace copy	Yellow—Dealer copy	Pink—Customer copy
--------------------------	--------------------	--------------------



## TABLE OF CONTENTS

1. Warranty Details	3
2. Heater Delivery Checklist	5
3. Introduction	9
4. Warnings & Cautions	11
5. Responsible Wood Burning	13
6. Heater Components	15
7. Heater Installation & Setup	19
8. Heater Controls (RG-5)	23
9. Heater Controls (MD-9 & LG-15)	27
10. Heater Controls (COM-32)	29
11. Fire Safety	35
13. Operating Your Heater	37
14. Maintaining Your Heater	41
15. Heater Model Specifications	45
16. Electrical Diagrams	47
17. Installation Examples	51





This Polar Furnace Updraft Heater is an upwards-firing, forced draft, wood-fired, hydronic heater. Polar Furnace heaters combine simplicity with exceptionally rugged construction into a product which will provide heat for many years.

### **!! NOTICE !!**

The warranty registration and delivery acceptance form is located on page 5. This form must be thoroughly completed and the white copy returned to Polar Furnace Mfg. Inc. to ensure product support and warranty activation.

This Model has been tested and approved by CSA INTERNATIONAL to  
CSA/CSA-366.1-M91 and UL2523

### **SAVE THESE INSTRUCTIONS**

---

Keep this manual for as long as you own your Polar Furnace heater. Read and understand these instructions before installing or operating this heater.



## WARNINGS & CAUTIONS

**!!WARNING!!** Read the manual carefully and follow instructions. Retain this manual for as long as you own your Polar Furnace heater.

**!!WARNING!!** All installations and operations must follow the applicable federal, provincial, state, and local codes for wiring, plumbing, chimney installation, chimney extension(if required) and firing of this unit. When the relevant local codes differ from this manual, the local codes take precedence.

**!!WARNING!!** Strictly maintain the following clearances around the heater to any combustibles including fuel storage. Front - 48", Rear - 6", Sides - 6", Top - 12", Flue - 6".

**!!WARNING!! DO NOT** burn garbage, gasoline, engine oil, coal, tires, railroad tiles or anything other than wood in your heater. Do not use chemicals or fluids to start the fire.

**!!WARNING!!** Burn wood only! Dry seasoned wood is preferable. The manufacturer does not recommend burning any treated or contaminated wood. (i.e. railroad ties or pressure treated lumber)

**!!WARNING!!** All Polar Furnaces operate at atmospheric pressure. DO NOT, in any way, obstruct, block or plug the overflow vent located on top of the heater. DO NOT install a pressure relief valve. Remove rear access cover before filling with water. This boiler should not be connected to an existing heating system unless a water to water or water to air heat exchanger is used.

**!!WARNING!!** Use of approved spark arrestor is strongly recommended.

**!!WARNING!!** Most Polar Furnace heaters are installed outdoors. All clearances on door panel should be observed. Always keep area around and in front of fire door cleared from combustible materials. DO NOT store fuel within clearances listed on label.

**!!WARNING!!** Polar Furnace heaters are CSA certified for outdoors and indoors. When used indoors special care must be take to insure the installation conforms to local installation requirements. Plan for make up air, ventilation of smoke when opening door, chimney clearances and heights, and clearances from combustibles. Consult local professionals. Field installations must satisfy CSA CAN/CSA-B365 installation code for solid fuel burning appliances as well as any other applicable standards or regulations. If extended chimney height is needed, use an insulated chimney system.

**!!WARNING!!** Installation should be completed by appropriately qualified individuals.

**!!WARNING!!** Never let small children play near or tamper with the heater. Only responsible adults should operate the heater. Fuel door surfaces may be hot during operation. Ensure children do not touch heater.

**!!WARNING!!** Keep fuel door tightly closed during operation.

**!!WARNING!!** Always turn fan switch off before opening door. Wait several minutes before opening door slowly while standing well back and to the right of the door. Do not look into the fire chamber until 60 seconds have passed. Failure to do so may result in serious injury from flashbacks.

**!!WARNING!!** In case of a runaway fire, disconnect the heater from the electrical supply and be sure all doors are closed. Check to ensure that the solenoid damper is not stuck open. Check aquastat settings. Add water to ensure that the heater is not low on water.

**!!WARNING!!** DO NOT operate heater unless it is full of water. Water should be added until it runs out the top of the fill pipe located on top of the heater.

**!!WARNING!!** Insulate the distribution pipes to avoid excessive wood consumption. Use appropriate piping to avoid heat loss to ground water.

**!!WARNING!!** The air inlet, chimney, and chimney extension should be cleaned regularly to remove accumulated creosote and ash.

**!!WARNING!!** Cleaning the firebox, flue pipes, chimney and fan is especially important at the end of the heating season to minimize corrosion. All accumulated ash **MUST** be removed.

**!!WARNING!!** Care should be taken to avoid potential smoke problems in the neighbourhood. Use a chimney extension if required.

## **Minimize Smoke Emissions. Burn Wisely.**

---

- Consider prevailing wind direction when choosing a site location for your heater.
- Water can be piped a long distance with minimal heat loss. This is a good option to avoid smoke related problems.
- Don't use updraft heater in urban built up area. For urban areas consider a smoke free downdraft unit.
- Don't overload heater. Small amounts of wood are better to control smoke. Load twice daily instead of filling only once completely with wood.
- Don't burn garbage. Burn only well-seasoned firewood.

## **Safety First!**

---

- Keep ground around heater clear.
- Use non-combustible cement blocks, patio blocks or cement base under heater.
- Install the rain cap on the chimney. Use an approved spark arrestor.
- Use a good quality pipe for hot water distribution.
- Only use environmentally friendly glycol solution. Ethylene glycol is not environmentally friendly and is not recommended. Do not use antifreeze or recycled glycol. If using glycol, do NOT use boiler treatment. Use a glycol mixture with a rust inhibitor included. Mix the propylene glycol with water according to the manufacturer's instructions. Check with manufacturer to insure glycol is intended for heating purposes and is compatible with all your system components including all distribution piping.
- **ALWAYS HIRE APPROPRIATELY QUALIFIED INSTALLERS.**



**RG-5 – Main Components**

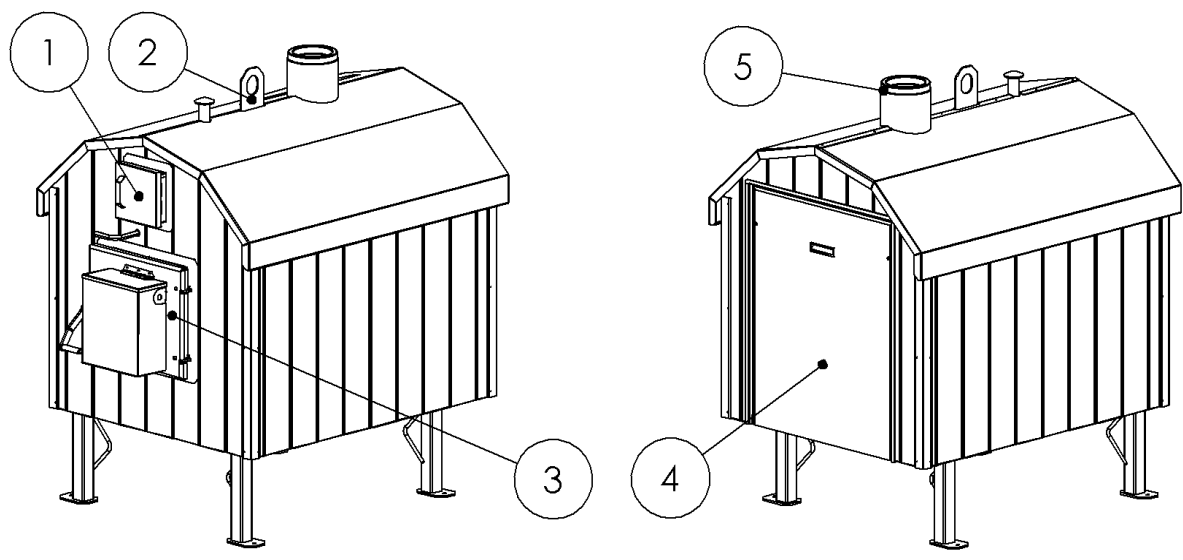

Item #	Description
1	Controls enclosure. Includes light and fan on/off switch, temperature gauge and sight glass.
2	Lifting/handling hook.
3	Fire chamber loading door.
4	Rear access panel for water and electrical hookup as well as access to combustion control aquastat and high limit shutdown aquastat.
5	Chimney connector.

## MD-9 & LG-15 – Main Components

---

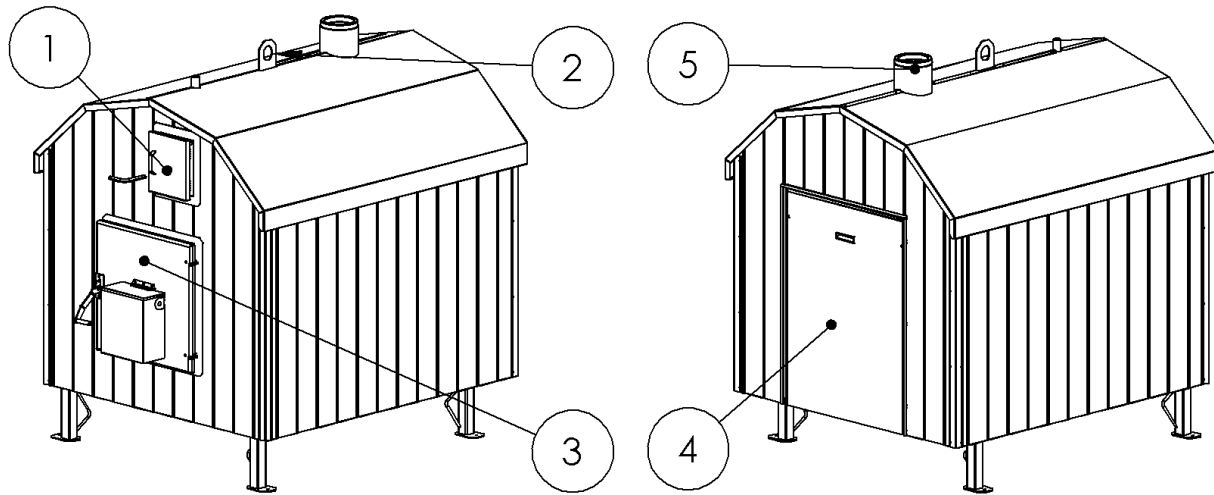

Item #	Description
1	Controls enclosure. Includes light and fan on/off switch, temperature gauge, sight glass, control aquastat, high temperature shutdown aquastat.
2	Lifting/handling hook.
3	Fire chamber loading door.
4	Rear access panel for water and electrical hookup.
5	Chimney connector.



## COM-32 – Main Components

---

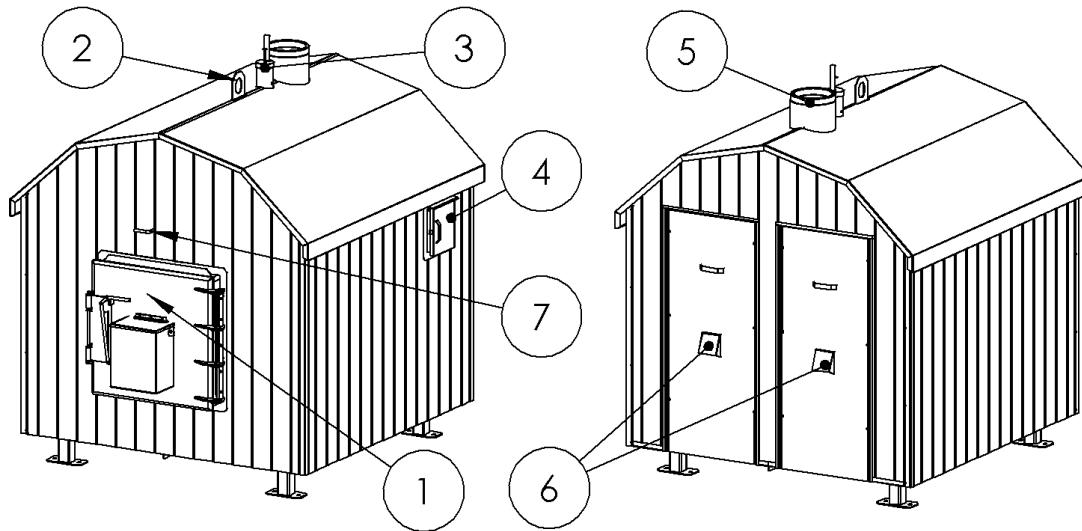

Item #	Description
1	Fire chamber loading door.
2	Lifting/handling hook.
3	Water level indicator
4	Controls enclosure.
5	Chimney connector.
6	Rear access panels to rear fan assemblies and plumbing and electrical hookup.
7	Bypass damper pullrod.



**All installation work must be completed by appropriately qualified personnel and must conform to all applicable standards, regulations and local codes (e.g. CAN/CSA-B365 Installation Code for Solid Fuel Burning Appliances).**

### Heater Fire Clearances

---

All Polar Furnaces are CSA approved to the following fire clearances. No combustibles should be stored within these measurements.

Front	48"
Back	6"
Left Side	6"
Right Side	6"
Top	12"
Chimney	6"

Consult with your insurance company to ensure that the boiler to building clearances are acceptable. Failure to do so may void insurance. The manufacturer assumes no liability in the event of damages to personnel or buildings.

### Indoor Installation

---

Polar Furnaces are CSA certified for both indoor and outdoor installation. However, care must be taken whenever a heater is near or inside a building. When installed indoors, proper air supply is required for combustion and ventilation. Continuous air supply is mandatory.

### Chimney

---

Chimney installations must conform to all applicable regulations and standards. All chimney extensions must be completed with approved prefabricated chimney pipe. The rain cap with spark arrestor must be installed at all times. Chimney extensions may require periodic cleaning.

# Heater Placement

## Foundation—Base Dimensions

**Note:** The foundation can be made from cement, crushed rock, packed A-base or patio bricks. The water supply and return lines must be installed so that they are protected against damage from an outside occurrence and protected against sunlight, freezing and fire.

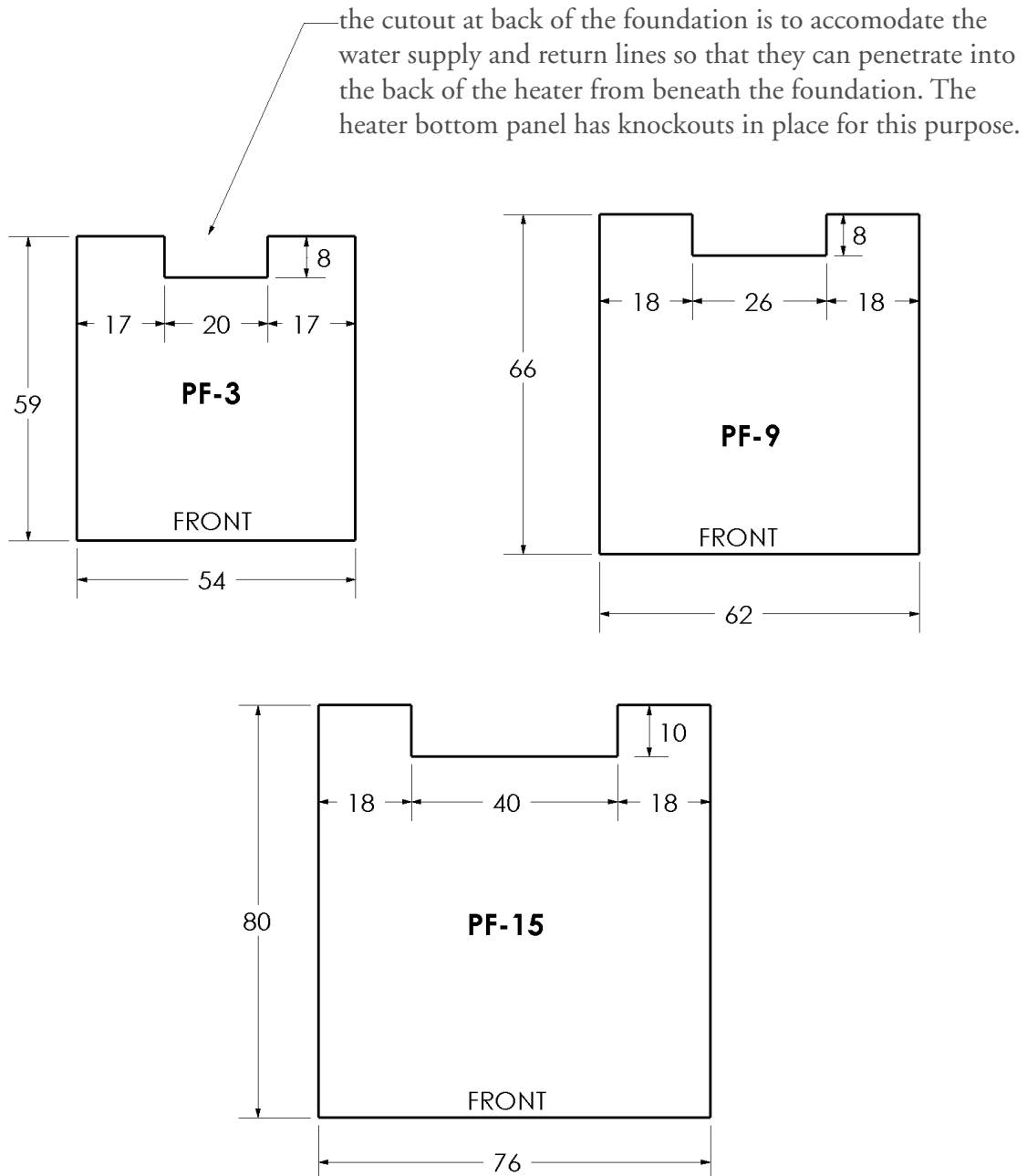

## Electrical Requirements

---

Electrical Rating: 120V AC, 6 amps, 60Hz. Installation must meet federal, provincial and local codes and must be completed by qualified personnel only. Wire must be rated and approved for direct burial if is to be included in the same trench as the water lines. Heater power connection box is located at rear of heater inside rear access panel. Minimum supply conductor ampacity is 15 amps. Maximum over current device is 15 amps. Use copper conductors only.

## Distribution Trench

---

An 18” deep ditch is recommended. When passing under a driveway or traffic area a 36” to 48” ditch is preferable. Prevent the underground pipe from lying in water.

## Waterline Hookups In Buildings

---

Do **NOT** connect to an existing system unless a water to water or water to air heat exchanger is used. We recommend a qualified installer complete the installation.

## Filling the Water Jacket

---

### **!! WARNING !!**

**Do NOT start a fire in the heater before filling the heater water jacket with water. Starting a fire in the heater without first filling the water jacket can damage or destroy your heater.**

### **!! DANGER!!**

**Do not pressurize your heater. All Polar Furnaces are designed with an open system type water jacket. Pressurizing the heater could result in damage to the heater, damage to property, and could cause severe bodily injury and death.**

This Polar Furnace hydronic heater heats water in the water jacket part of the heater. The water jacket must be filled with water or a water/glycol mixture before operating the heater. Filling the water jacket can be achieved by hooking the supply to the drain/fill valve located inside the rear access panel. Alternately, the water jacket can be filled by adding water into any part of the hot water distribution piping. Fill the heater until water starts showing up in the sight tube or until water starts coming out of the overflow pipe on top of the heater. The sight tube is located inside the controls enclosure except for the COM-32. The COM-32 model has a sight gauge on top of the heater.

## **Water Treatment**

---

See instructions included with water treatment kit.

## **Using the Water Level Sight Tube**

---

The sight tube is located at the top of the water jacket. Before firing the heater for the first time, fill the water jacket until the water level starts showing up in the sight glass. When the heater is up to operating temperature add water until it comes out of the overflow pipe on top of the heater. During operation check the water level in the sight gauge daily and keep the heater as full of water as possible. Add water as needed.

## **Heater Delivery**

---

Wash heater thoroughly immediately following delivery to remove salt and dirt from shipping. Inspect the furnace for shipping damage. If damaged, make note of it on carrier shipping paperwork. Check to insure all of the following items were shipped with your furnace: outdoor light globe, 12" insulated chimney extension, rain cap, water treatment kit, owners manual. If any items missing make note on carriers paperwork of missing items.

## RG-5 – Controls Overview

(See page 15 for location for this model's controls.)

### Inside Front Enclosure:

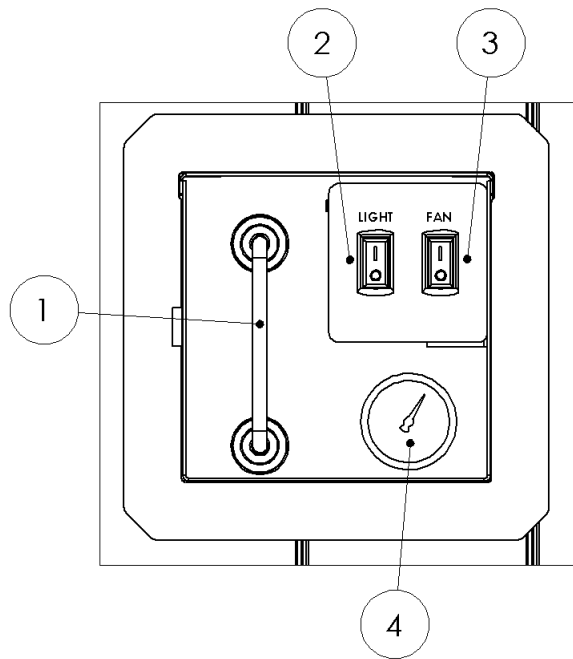

Item #	Name	Function Description
1	Sight Gauge	Shows the water level in water jacket.
2	Light Switch	Used to switch work light ON or OFF.
3	Fan Switch	Used to switch fan ON or OFF.
4	Temperature Gauge	Shows temperature of water in water jacket.

## Inside Rear Access Panel:

---

The Control Aquastat and High Temperature Aquastat are located inside the rear plumbing enclosure at the rear of the heater.

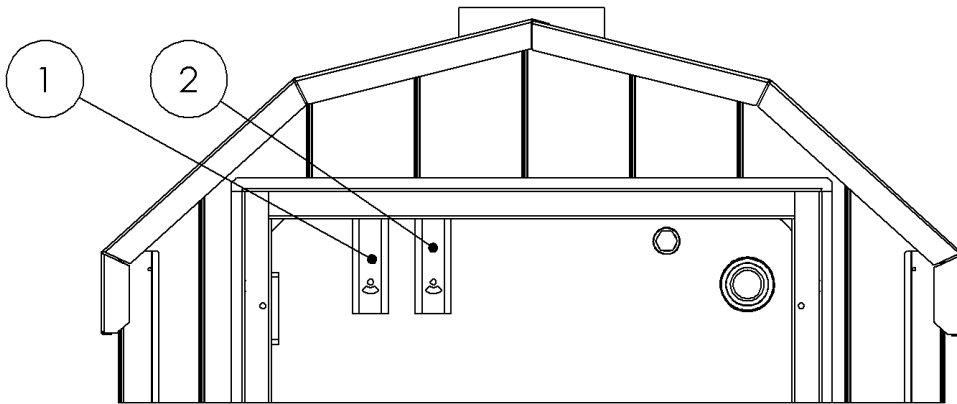

Item #	Name	Function Description
1	Control Aquastat	Controls heater combustion fans.
2	High Temperature Aquastat	High temperature shutdown protects heater against over-heating.



## RG-5 – Controls & Functionality

---

### Fan ON/OFF Switch

This switch turns the combustion fans on or off. When the switch is in the “OFF” position, the fans remain off even when the controller is signaling the fans to switch on. When the switch is in the “ON” position, the fans switch on but only if the temperature control aquastat is also signaling the fans to switch on.

### Light Switch

Used to switch the outdoor work light ON or OFF.

### Control Aquastat

The Control Aquastat is used to set the water temperature at which the heater switches the combustion fan off and at which water temperature the combustion fan switches on during normal operation. The Control Aquastat is set to 180°F with a 20°F differential at the factory. In most installations this setting will work well. The Control Aquastat should never be set higher than 185°F or lower than 175°F.

### High Temperature Aquastat

The High Temperature Aquastat is used to protect the heater against over-heating if the Control Aquastat should fail. If the high temperature set point is reached the fans are switched off. The High Temperature Shutdown Aquastat is factory set to 195°F. It should never be set higher than 195°F and should be at least 8°F degrees higher than the Control Aquastat set point.



## HEATER CONTROLS (MD-9 & LG-15)

### MD-9 & LG-15 – Controls Overview

(See page 16 for location for these models' controls.)

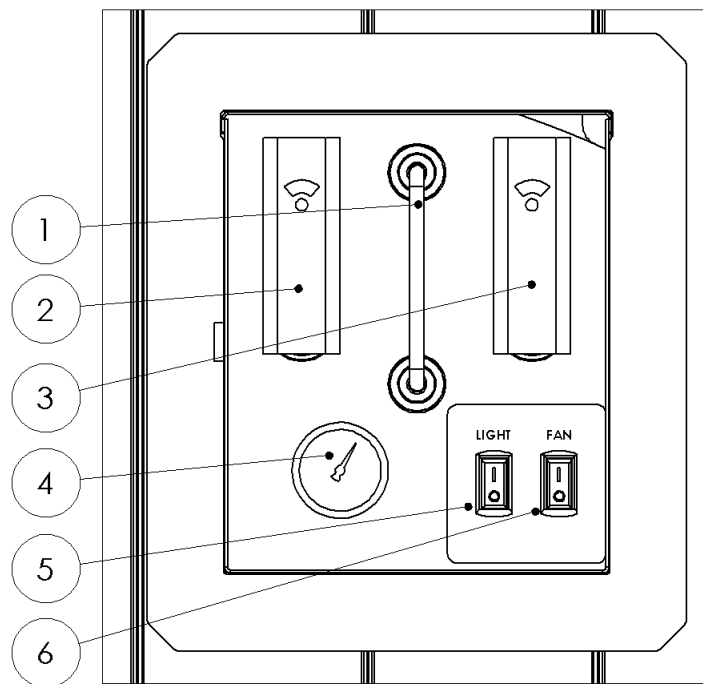

Item #	Name	Function Description
1	Sight Gauge	Shows the water level in water jacket.
2	Control Aquastat	Controls heater combustion fan.
3	High Temperature Aquastat	Protects heater from overheating if Control Aquastat fails.
4	Temperature Gauge	Shows temperature of water in the water jacket.
5	Light Switch	Used to switch light ON or OFF.
6	Fan Switch	Used to switch fan ON or OFF.

## MD-9 & LG-15 - Controls Functionality

---

### Fan ON/OFF Switch

This switch turns the combustion fans on or off. When the switch is in the “OFF” position, the fans remain off even when the controller is signaling the fans to switch on. When the switch is in the “ON” position, the fans switch on but only if the temperature control aquastat is also signaling the fans to switch on.

### Light Switch

Used to switch the outdoor work light ON or OFF.

### Control Aquastat

The Control Aquastat is used to set the water temperature at which the heater switches the combustion fan off and at which water temperature the combustion fan switches on during normal operation. The Control Aquastat is set to 180°F with a 20°F differential at the factory. In most installations this setting will work well. The Control Aquastat should never be set higher than 185°F or lower than 175°F.

### High Temperature Aquastat

The High Temperature Aquastat is used to protect the heater against over-heating if the Control Aquastat should fail. If the high temperature set point is reached the fans are switched off. The High Temperature Shutdown Aquastat is factory set to 195°F. It should never be set higher than 195°F and should be at least 8°F degrees higher than the Control Aquastat set point.

## COM-32 – Controls Overview

(See page 17 for location for this model's controls.)

### HEATER CONTROLS (COM-32)

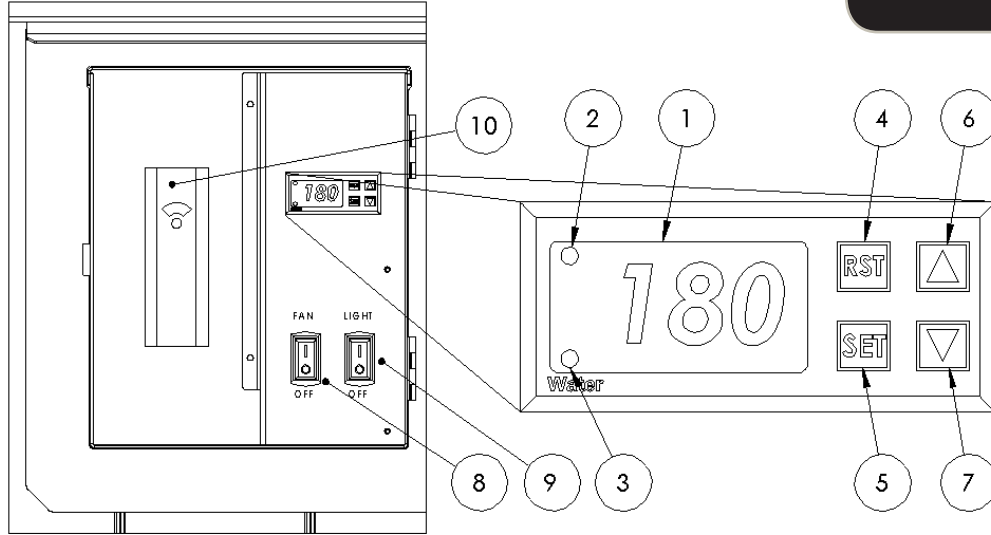

Item #	Name	Function Description
1	Display	During normal operation this shows the temperature of the water in the water jacket. During programming this shows the various parameters that can be modified.
2	Low Temperature Indicator	Light off—indicates normal operating temperature. Light blinking on/off—indicates a low temperature shutdown condition.
3	Low Water Indicator (optional)	Light off—indicates normal water level. Light on—indicates a low water level.
4	RESET	Used to Start and Restart the Furnace. Also used to temporarily bypass a low temperature shutdown condition.
5	SET	Used to store settings after making a change when programming the controller.
6	UP	Used to navigate up in a menu when programming the controller.
7	DOWN	Used to navigate down in a menu when programming the controller.
8	Fan Switch	For switching fan ON or OFF. In the ON position the fans will only turn on when the controller is also calling for heat.
9	Light Switch	For switching light ON or OFF.
10	High Temperature Aquastat	Switches fans off if controller fails and boiler overheats.

## COM-32 – Controls Functionality

---

### Fan switch

This ON/OFF switch switches the combustion fans on or off. When the switch is in the “OFF” position the fans remain off even when the controller is signaling the fans to switch on. When the switch is at the “ON” position the fans switch on but only if the Temperature Control Aquastat is also signaling the fans to switch on.

### Light Switch

Used to switch the outdoor work light ON or OFF.

### Digital Controller

The COM-32 heater is equipped with a Digital Controller that provides the following functionality:

- **Combustion Control**

The controller will switch the primary and secondary combustion fans on and off as is required to start and stop combustion in the heater.

- **Low Temperature Shutdown**

The digital controller has a built in Low Temperature Shutdown feature. This feature shuts down the combustion fans when the unit has run out of wood. The controller senses this condition by monitoring the water jacket temperature. When the wood in the fire chamber is used up, the temperature in the water jacket continues to fall even though the controller switches on the fans to try and start combustion. When the temperature of the water drops below a programmed temperature set point, the controller switches the fans off and switches on a blinking low temperature indicator light on the digital controller.

- **Low Water Level Indicator**

The controller will indicate a low water condition by switching on an indicator light on the controller. This warning helps protect your heater from being damaged by overheating as well as your water circulation pumps from running dry.

## COM-32 – Operating the Controller

---

Once the controller is programmed at the factory there isn't much you need to do on the controller to run your heater through the heating season. The controller is intelligent enough that it will manage the combustion process automatically while there is wood and fire in the fire chamber. The only time you need to press a button on the digital controller during normal daily operation is when the digital controller signals a low temperature condition and shuts off the combustion fans. When a low temperature condition occurs, the RST or RESET button on the controller needs to be pressed once and held for several seconds. When the RESET button is pressed and held, the controller will ignore the low temperature condition for 90 minutes or until the temperature of the water has climbed 5 degrees over the Low Temperature Set Point which is factory set to 150°F. If, after 90 minutes the temperature of the water in the water jacket has not climbed to 150°F + 5°F or 155°F, the low temperature condition will again become active and the fans will shut off again.

### COM-32 - Controller Programming Parameters and Descriptions

---

	Description	Factory Settings
HSP	Set point at which the fans shut down on a satisfied water temp.	180
LSP	Set point at which the fans shut off due to low water temperature (Low Fuel/Cold Water).	150
<b>r0H</b>	<b>Differential between HSP and the lower temperature at which fans come on during normal combustion.</b>	<b>15</b>
r0L	Differential between LSP and the higher temperature at which fans will remain on after resetting a low temperature condition.	5
r1	Lowest possible temperature setting for HSP.	160
r2	Highest possible temperature setting for HSP.	190
r3	Lowest possible temperature setting for LSP.	130
r4	Highest possible temperature setting for LSP.	155
t1	Time (minutes) Low Set Point (LSP) is inactive after reset (RST) is pressed.	90
H5	Access code to parameters.	00

## COM-32 - Adjustments to the Digital Controller Settings

---

### **NOTE:**

The digital controller is preset at the factory to a cut-out temperature of 180°F and a differential of 15°F. With these settings the combustion fans will cut-in (start) at 165 °F and cut-out (stop) at 180°F.

### **To change the temperature cut-out setting (fan STOPS during normal combustion)**

- Press **SET**. *HSP* text will appear on the display.
- Press **SET** again. The set value is shown on the display.
- The value can be modified with the **UP** and **DOWN** arrow keys.
- Press **SET** to enter any new values.
- Press **SET** and **DOWN** at the same time to quit programming or wait one minute and the display will automatically exit programming mode.

### **To change the temperature differential (fan STARTS during normal combustion)**

- Press **SET** for 8 seconds.
- The access code value 00 is shown on the display. (Unit comes from factory with access code set to 00).
- Press **SET** to enter the code. If the code is correct, the first parameter label is shown on the display (**SP**).
- Press the **UP** or **DOWN** arrow keys until (**r0H**) is displayed on the screen.
- Press **SET** to view the currently set differential.
- The value can be modified with the **UP** and **Down** arrows.
- Press **SET** to enter the value and exit to text parameter.
- Press **SET** and **DOWN** at the same time to quit programming or wait one minute and the display will automatically exit programming mode.



## The LSP and r0H Parameters

---

### **!! IMPORTANT !!**

The LSP Parameter is NOT used to set the lower temperature at which the combustion fans turn on. The lower temperature at which the fans turn on during normal combustion is defined by the r0H parameter. Please review parameters and descriptions on page 31.

### **!! IMPORTANT !!**

The r0H parameter is used to set the temperature at which the combustion fan/s turns on. If the r0H setpoint is modified to increase the differential or temperature spread over which the heater operates, the Low Water Temperature Setpoint (LSP) needs to be lowered an equal amount or more.

### **COM-32 – The High Temperature Shutdown Aquastat**

The High Temperature Shutdown Aquastat is factory set to 195°F and should never be set higher than this setting.

### **COM-32 – The Controls Circuits Protection Fuse**

The control circuits are protected by a slow blow 8 amp fuse. In the event of an electrical problem this fuse may burn out and need to be replaced. The fuse should be replaced with another one of identical specifications. Failure to use the proper fuse can result in electrical damage to components making up the heater controls. The fuse holder is located inside the controls enclosure on the side of the digital controller mount plate. To replace a blown fuse, twist the top part of the fuse holder counter clockwise. Place the new fuse in position and recap the holder.

### **COM-32 - Water level indicator**

The COM-32 model is equipped with a highly visible water level indicator assembly mounted on the roof of the heater (see pg. 17 item #3). Check water level daily. Add water as needed to keep the indicator near the FULL position.



**!! WARNING !!** Maintain minimum distances between heater and combustibles.

**!! WARNING!!** Have a clearly understood plan of how to handle a chimney fire.

**!! WARNING!!** Keep area around heater clear of combustibles.

## **Flashbacks**

---

### **!! CAUTION !!**

ALWAYS KEEP BODY AND FACE WELL AWAY FROM LOAD DOOR, ACCESS DOORS AND CLEANOUT DOORS WHILE OPENING THEM. FAILURE TO DO SO CAN RESULT IN SERIOUS BODILY INJURY FROM FLASHBACKS.

When opening any access panels on the heater there is a danger of flashbacks. It is important to understand what causes flashbacks before operating the heater. Read the following explanations carefully and be sure to understand what flashbacks are before attempting to operate the heater.

### **Cause of Flashbacks**

The root cause of flashbacks is the accumulation of oxygen-starved hot gases inside the fire chamber. These gases cannot combust without oxygen. Opening the load door allows fresh air and oxygen to mix with the hot gases causing them to ignite, burn suddenly or explode.

### **Conditions Causing Flashbacks**

There are some combustion conditions that greatly increase the risk of flashbacks. It is important to understand these conditions. They are explained below. However, it is important to note that flashbacks can happen at any time the load door is opened and are not only limited to the combustion conditions described below!

## The Combustion Fans Have Just Shut Off

---

Once the heater reaches the point where the water temperature is high enough, the controller shuts off the combustion fans. When the fans stop blowing, actuators also close off the air supply openings. This stops any new air and oxygen from getting into the fire chamber. At this point the fire chamber is still extremely hot. The heat in the fire chamber continues to bake the wood and it continues to break down into combustible smoke and gases. Without oxygen these combustible hot gases do not burn off and accumulate in the fire chamber. When a door is opened, fresh air and oxygen mix with the hot combustible gases which then ignite and explode. **Always keep face and body well away from door when opening the load door.**

## Hot Surfaces

---

There are surfaces on the boiler that get very hot. These surfaces are labeled with hot surface labels. Always wear protective leather gloves when working on or around the heater. This includes when loading the heater and when performing maintenance on the heater.

## Smoke Inhalation / Eye Irritation

---

Burning wood produces smoke. Avoid inhaling smoke. Whenever there is smoke, wait until smoke has cleared before proceeding to load your heater or perform maintenance work.

### Before You Begin

---

Do not use any flammable liquid (gasoline, lighter fluid, diesel, etc) to help start or maintain a fire in your heater as this can result in serious bodily injury and damage to your heater and property.

Do not burn anything other than properly prepared wood in your heater. Do not burn garbage, treated wood, plastic, oil, coal or anything other than properly prepared fire wood.

Be sure to keep all combustibles outside of the fire clearances as specified. See page 19 of this manual for fire clearances.

The heater is designed to have an open or unpressurized water jacket. Pressurizing the heater can cause damage your heater, property and/or cause bodily harm.

### Wood Fuel Considerations

---

Dry firewood is the recommended fuel source for the Regular Series heaters. The optimum moisture content of the wood used to fuel the heater should be between 15% and 26%. The best way to determine wood moisture content is with a moisture meter, although with practise, moisture content can be estimated accurately without a moisture meter. As a general rule, hardwood cut, split and stacked for one year under cover will usually have dried to within the 15%-26% moisture content level. Wood that has been properly stored for two years is best. The manufacturer cannot be responsible for problems related to using wood that is not adequately dry. Using fuel types that are freshly cut may result in unpredictable operation, poor efficiency and a shortened heater life.

### Starting and Operating the Heater the First Time

---

Before starting your heater for the first time, the installation should be inspected and approved by an individual with appropriate qualifications (electrician, plumbing and/or heating contractor etc.) The heater and all heating system piping must be properly filled with water.

When starting the heater for the first time after purchasing or when starting for the first time at the beginning of a heating season, follow the following steps:

1. Place the fan switch to the OFF position.
2. Pull the bypass damper out approximately 10”.
3. Place a layer of small pieces of wood, kindling and newspaper into the fire chamber.
4. Light the newspaper.
5. Leave the door open until the kindling has caught fire well.
6. Turn the fan(s) on and close the load door.
7. After 15 minutes, add more pieces of wood.
8. Add wood as needed.

**Note: During the initial startup keep circulator turned off until heater reaches 180°F.**

---

## Stoking the Heater

---

When stoking the heater, don't fill the fire chamber completely with wood. Fill the fire chamber approximately  $\frac{3}{4}$  of the way to the pipes on the top of the heater. Filling the fire chamber completely with wood will often cause the heater to smoke excessively for a long period of time. If filled only  $\frac{1}{2}$  or  $\frac{3}{4}$  full the heater will smoke much less.

---

## Managing the Ash/Coal Bed

---

After using your heater for a few days you will notice a buildup of ash and coals at the bottom of the fire chamber. This layer should not be removed and creates an insulating layer between the fire and water jacket surface. This allows the fire to burn hotter and cleaner. This ash/coals layer can be several inches thick. If the buildup becomes excessive, part of it can be removed. Leave an inch or two in place to insulate the next fire.

---

## Shutting Down the Heater

---

The heater can be turned off manually by switching the fans switch to the OFF position. Or, the heater will switch off when the water temperature in the water jacket gets too low (COM-32 only).

## Operating Temperature

---

The water temperature in the water jacket should always be above 150°F. Maintaining proper water temperature in the heater is important for two reasons:

1. Proper combustion—cool water cools the combustion process which reduces the combustion efficiency.
2. Heater longevity—cool water cause condensation to form on the fire-side surfaces. This condensation results in creosote buildup throughout the heater. Moisture or water mixed with ashes is corrosive and will shorten the life of your heater.

## Air Gate Setting

---

Beneath the fan(s) is a slider or damper which can be pushed upwards to choke off the air supply to the heater. This will reduce the fire size and rate of burn in the chamber and will reduce the amount of BTUs the unit generates. To adjust the slider, loosen the two bottom screws holding the fan in place and tap the slider upwards or downwards. Once the desired adjustments are made, retighten the screws holding the fan in place.

## Disposal of Ashes

---

Ashes should be placed in a metal container with a tight fitting lid. The closed container of ashes should be placed on a non-combustible floor or on the ground well away from all combustible materials.

## Creosote

---

Excessive creosote should be removed from the fire chamber, horizontal tubes and the chimney. Excessive creosote in the chimney can lead to a chimney fire. The chimney should be inspected at least monthly and any excessive creosote should be removed.

## Recommendations

---

Add dry wood twice a day instead of large amounts once a day. Use dry wood instead of wet wood. Dry wood will deliver more BTUs per cord than wet wood.





## **General Maintenance**

---

Proper maintenance of your heater is important for reliable, efficient and safe operation. Proper maintenance will also result in a longer service life of your heater. There are daily maintenance guidelines, monthly guidelines and end of season guidelines that should be understood and followed.

## **Tools Needed for Operation and Cleaning**

---

To effectively operate and maintain the heater the following tools are needed.

- A poker or rod.
- A shovel.

## **Weekly Maintenance**

---

Check Water level. Keep heater as full of water as possible. Pull the bypass pull rod out the whole way to remove fly ash from upper chamber. Remove the ashes and coals from the front of the fire chamber and pull ashes/coals from the rear of the fire chamber towards the front of the fire chamber.

## **Monthly Maintenance**

---

Remove accumulated ash as required. Maintain an ash bed depth of no more than 8-10 inches. Ashes should be stored in a steel container with a tight fitting lid.

## End of Heating Season / Yearly Maintenance

---

After all heating seasons, **ALL** ashes must be removed from fire chamber. Inspect and clean the firebox, horizontal tubes, air bypass and chimney to ensure there is no accumulated creosote or ash. After cleaning, rub new, unused motor oil on the inside surfaces of the heater to protect against moisture. Ensure water, rain, or moisture cannot enter firebox through chimney as ashes and moisture can create a very corrosive environment. Inspect fan to ensure blower is turning freely. Check fresh air solenoid to ensure free movement. Check door gasket and replace as needed. Test and maintain water with water treatment kit. Turn off electrical power at end of season.

## Maintaining Tight Door Seals

---

Maintaining tight door seals will help keep the front of your heater looking good. The fiberglass rope used to seal the fire chamber door should be inspected regularly. If a glass rope becomes too flattened and/or worn it should be replaced.

A leaking door seal results in slow but steady combustion of wood during the off cycle. This results in more wood being used which reduces the overall efficiency of your heater.

## Off Season Preparation

---

Creosote and/or ash mixed with water produces a corrosive acid. This acid can form inside the fire chamber of the heater during the off season. It is important that the boiler be properly prepared for the off season period (when the heater is idle) to avoid formation of this acid. All the ash and coals at the bottom of the chamber should be removed. Any excessive buildup of creosote on the heater walls and tubes should be scraped off. (It is not necessary to clean the creosote off down to the bare metal. Hard baked creosote will actually protect the steel against corrosion). If possible the chimney should be sealed off with a plastic cap or wrap to insure no water gets into the heater. Check the fire chamber regularly to insure there is no water building up in the fire chamber.

### **!!REMEMBER!!**

ASH + MOISTURE = CORROSIVE ACIDS.

ACID WILL CORRODE AND DAMAGE YOUR HEATER. REMOVE ALL THE ASH AND CREOSOTE FROM THE FIRE CHAMBER WHENEVER THE HEATER IS SHUT DOWN FOR MORE THAN 2 WEEKS. SEAL THE CHIMNEY.

## Anode Rod

---

Your heater is protected by a sacrificial anode rod. A sacrificial anode rod works by “sacrificing” itself and corroding first before the heater steel corrodes. Over time corrosion will wear the anode rod down until it is completely sacrificed or used up. In order to keep protecting your heater from corrosion, the anode rod needs to be replaced. The length of time the anode rod will help protect your heater will vary depending on the chemistry of your water. It is recommended that you check your anode rod every 2 years and replace it if it has worn down to about a ½” diameter.

### Checking and Replacing the Anode Rod

The anode rod(s) are located inside the rear plumbing compartment. On some models it is necessary to remove the two pieces of sheet metal on the sides of the rear access panel to expose the anode rods. When the anode rod is removed, water will leak and then pour from the hole. The following are some tips to replace the anode rod without making a huge mess and losing a lot of water from the water jacket.

- 1. Do not attempt to check or replace the anode rod without having a new anode rod nearby.**  
The anode rod may be so corroded and thin that it could bend upon removal and it might be very difficult or impossible to replace the old rod.
2. Hang a large pail on the mounting stud into which the anode rod is screwed before removing the rod. This pail will collect any water that will drip/flow from the mounting stud when the anode rod is loosened.
3. Before completely removing the anode rod from the mounting stud, cover the area with a large rag. When the anode rod is completely removed, keep your hand and rag over the mounting stud opening to stop/slow the water flow and to direct the water down into the pail.
4. Have the spare anode rod nearby so you don't have to remove your hand from the mounting stud to pick up the new replacement rod.
5. Using the rag and your hand to deflect water downwards, slide the new rod into the mounting stud and tighten.



## HEATER MODEL SPECIFICATIONS

### Heater Specifications

Specifications*	U of M	RG-3	MD-9	LG-15	COM-32
Overall Height	A-inch	70	78	87	111
Overall Width	B-inch	48	56	69	94
Overall Length	C-inch	67	75	87	109
Wood Load Door Opening (W x H)	inch	16.5 x 16.5	19.5 x 19.5	23.5 x 26.5	35 x 35
Max. Wood Length	inch	37	44	55	72
Diameter of Supply and Return Fittings	inch	1.5	1.5	1.5	1.5 (2)
Chimney Connection (Approx. Height)	F-inch	70	78	87	106

*\*Specifications subject to change without notice*

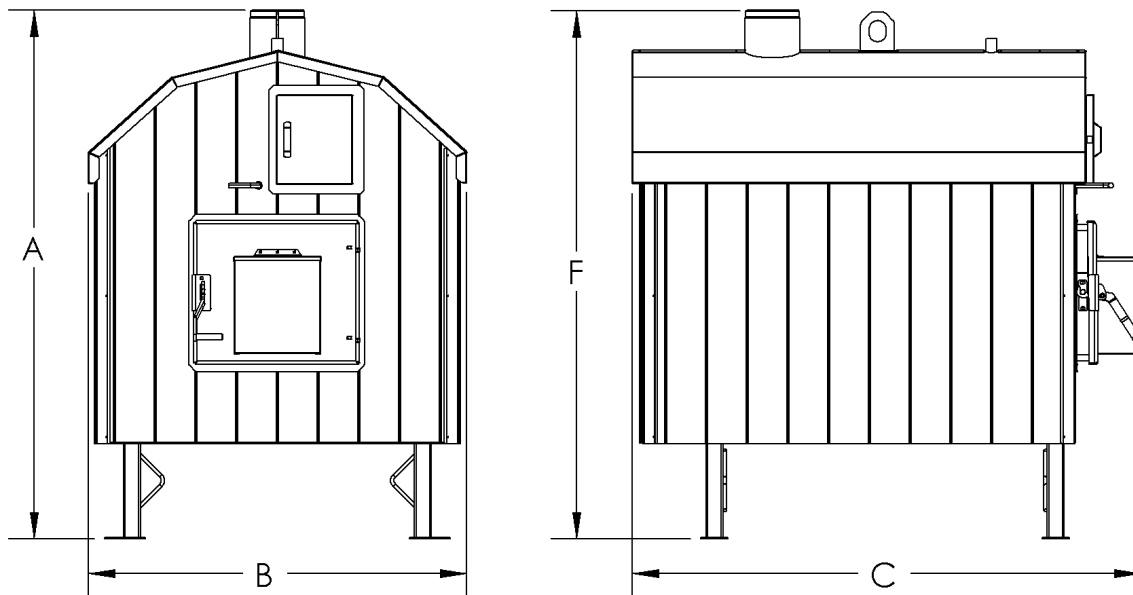



**RG-5 Electrical Diagram**

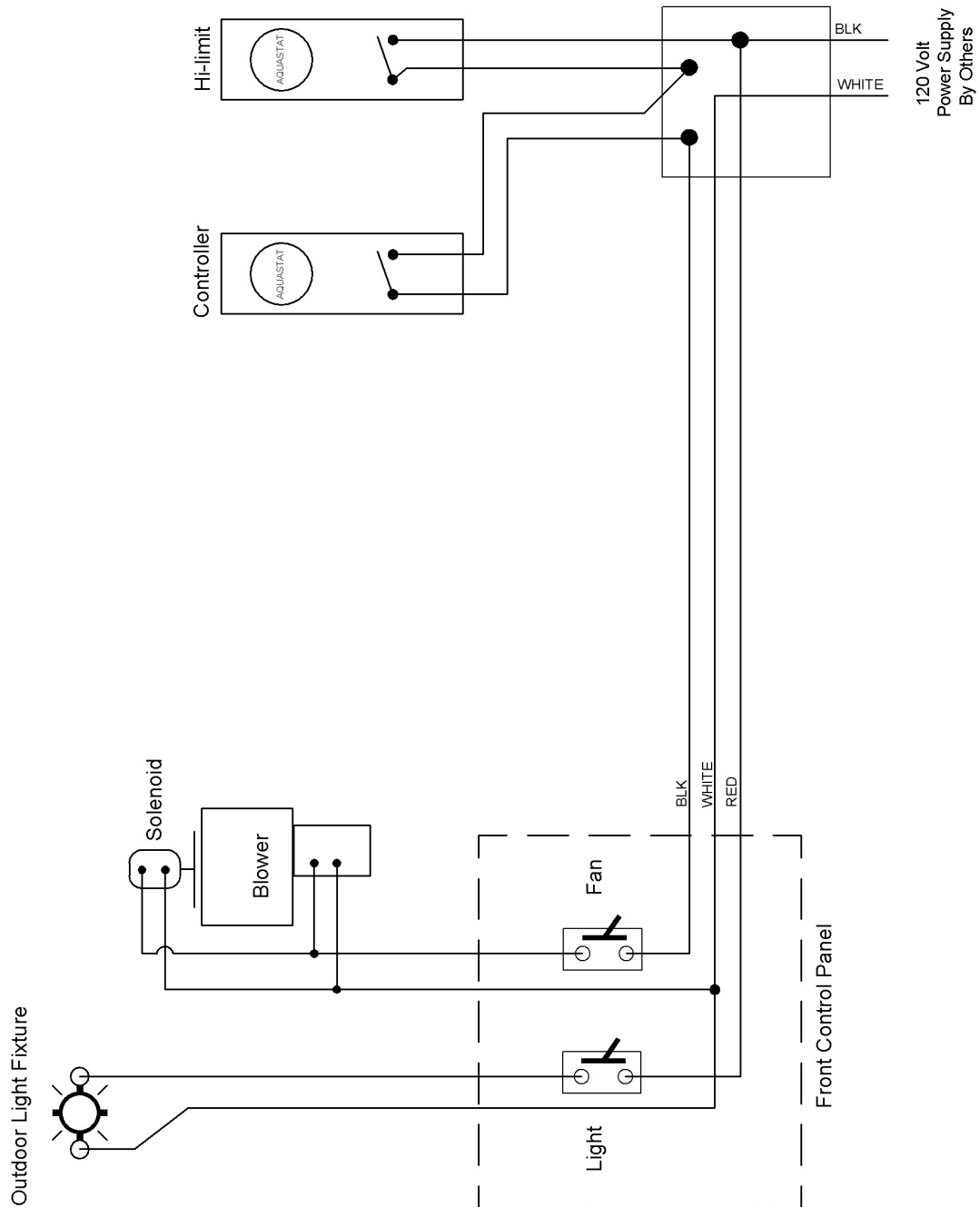

# MD-9 & LG-15 Electrical Diagram

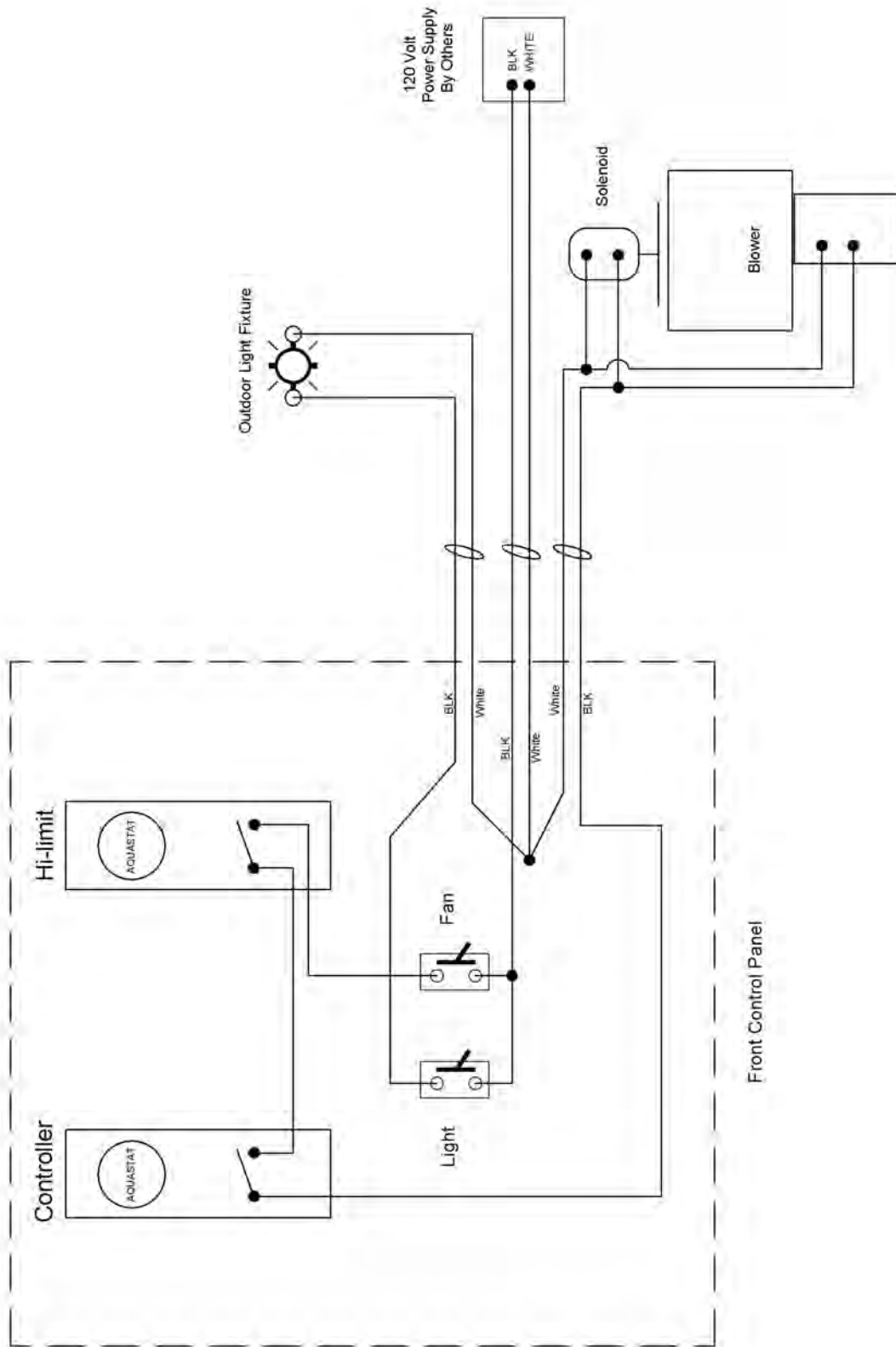



# COM-32 – Electrical Diagram

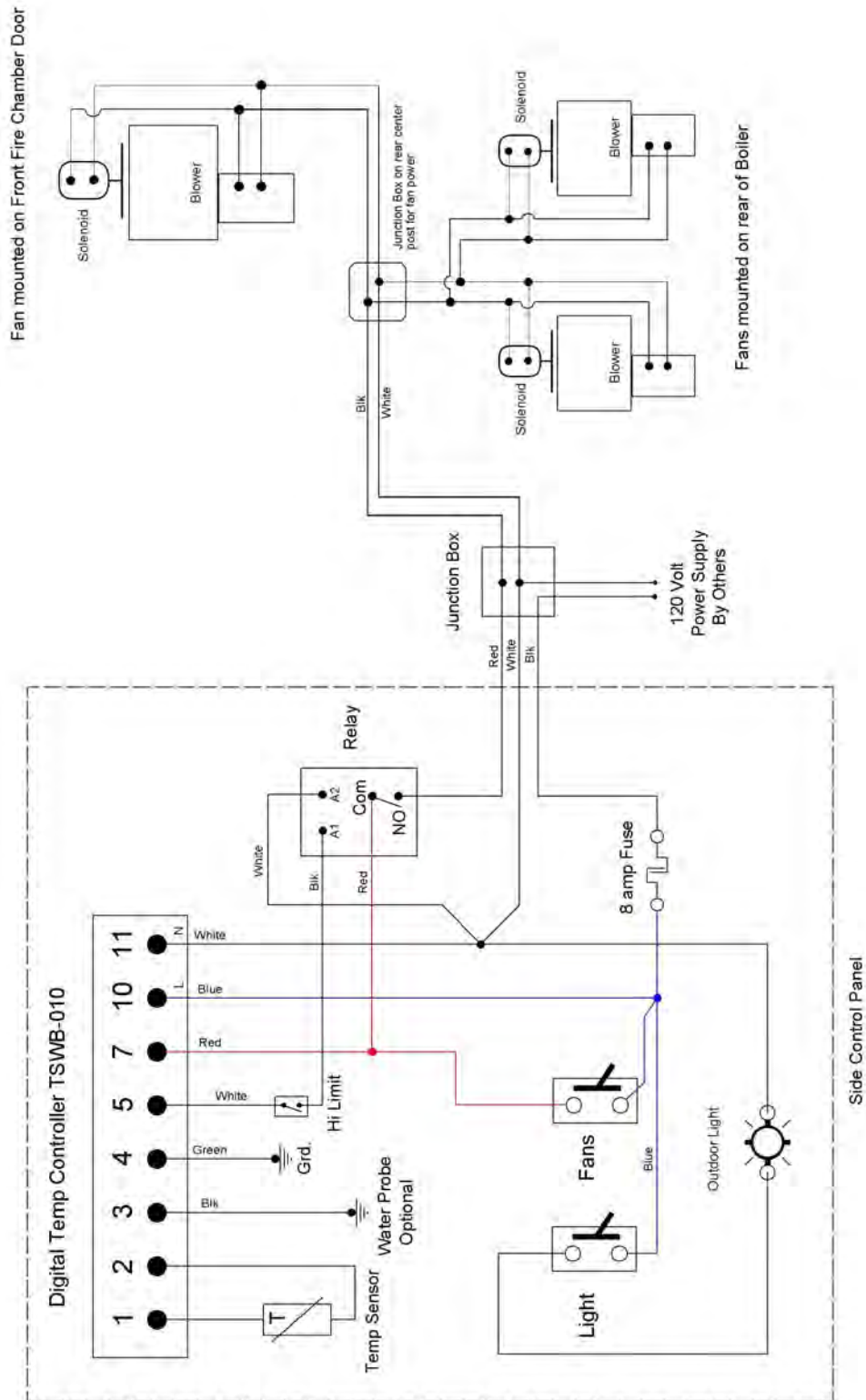



# INSTALLATION EXAMPLES

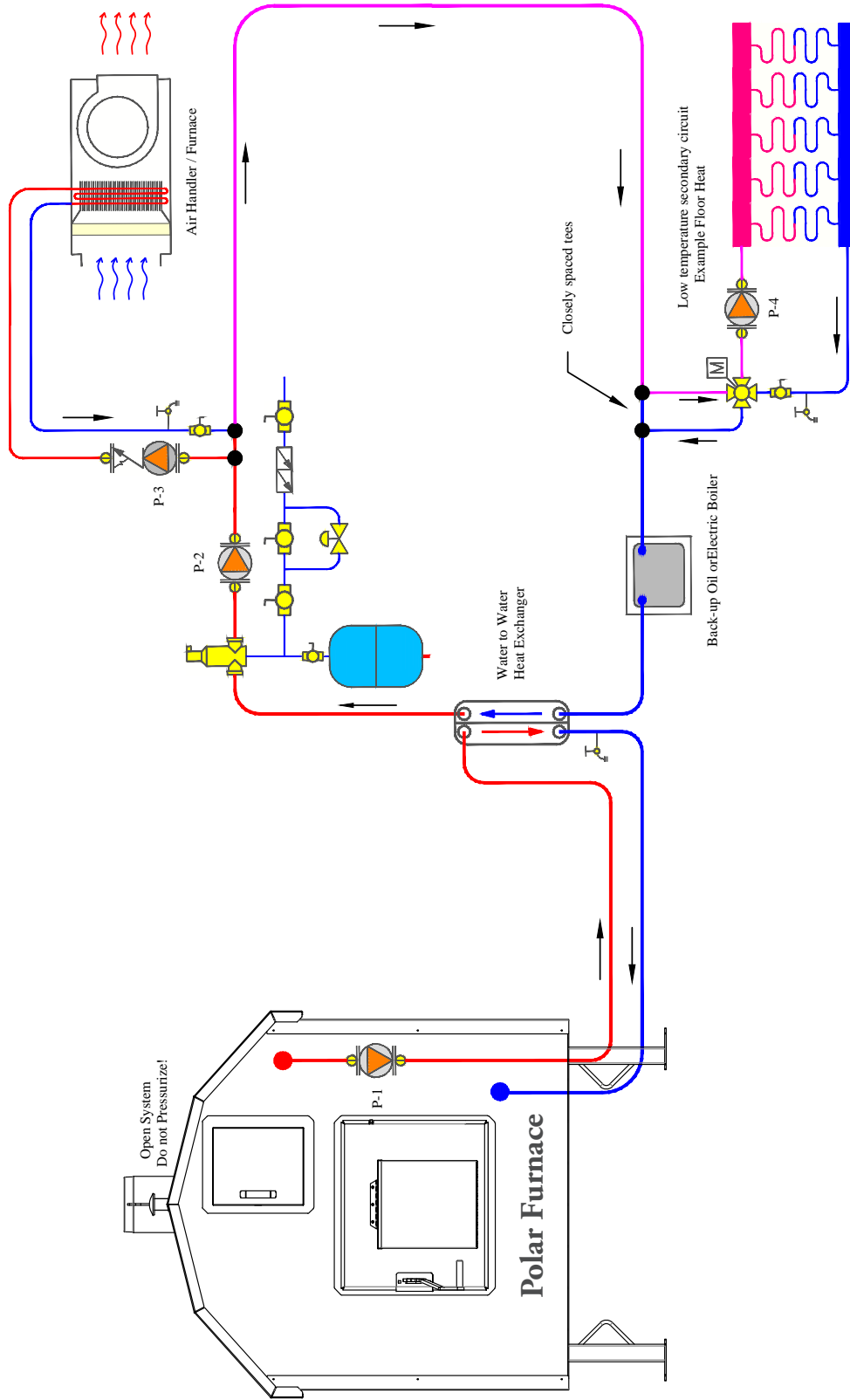

- P-1 Circulates constantly
- P-2 Circulates constantly
- P-3 Circulates on thermostat call
- P-4 Circulates on thermostat call

NOTES:  
 Installer must comply with all applicable codes and regulations.  
 For illustration purposes only.

# In-House Piping Example for Forced Air

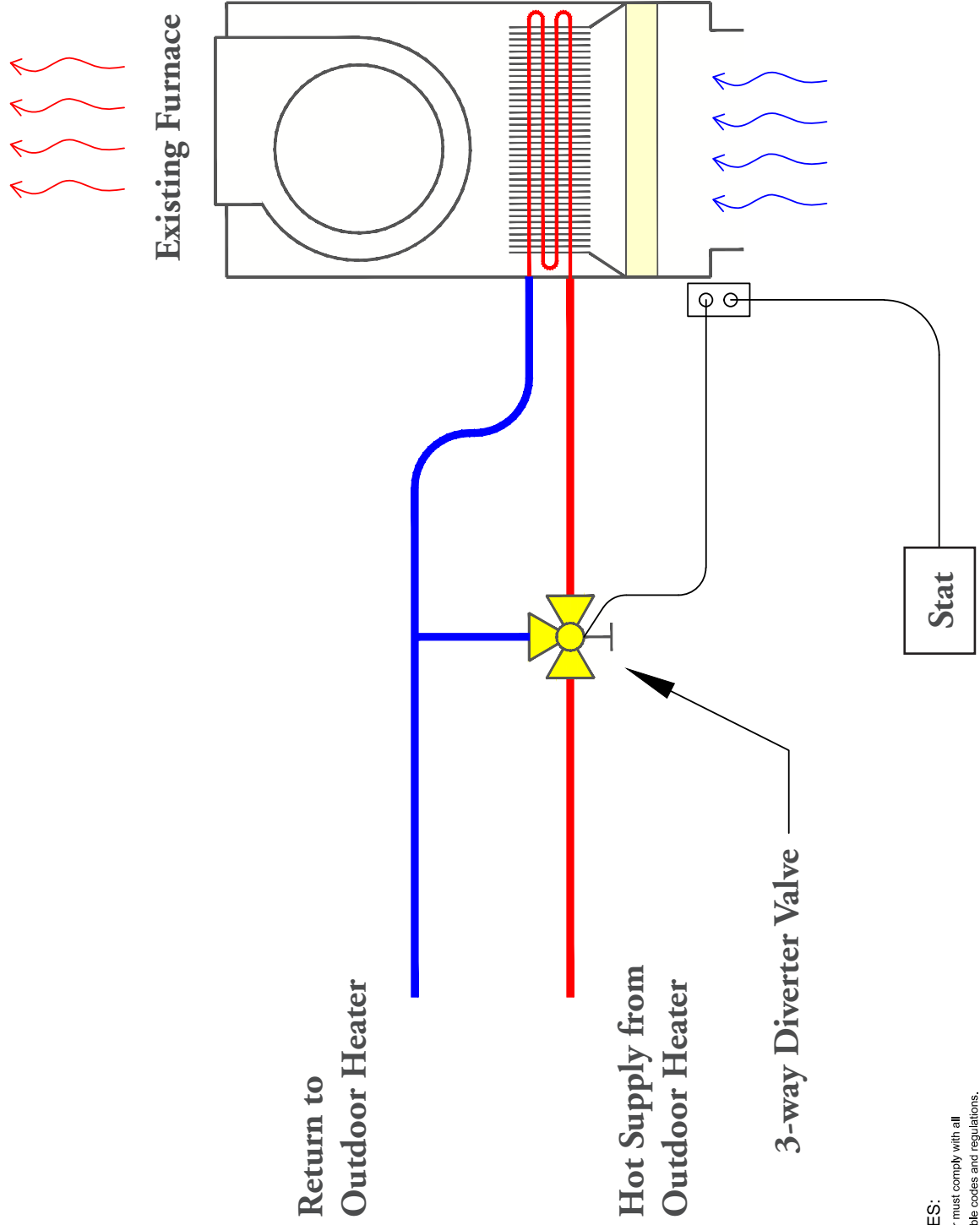

**NOTES:**  
Installer must comply with all applicable codes and regulations.  
For illustration purposes only.

# Electric Hot Water Tank: Sidearm Installation Example

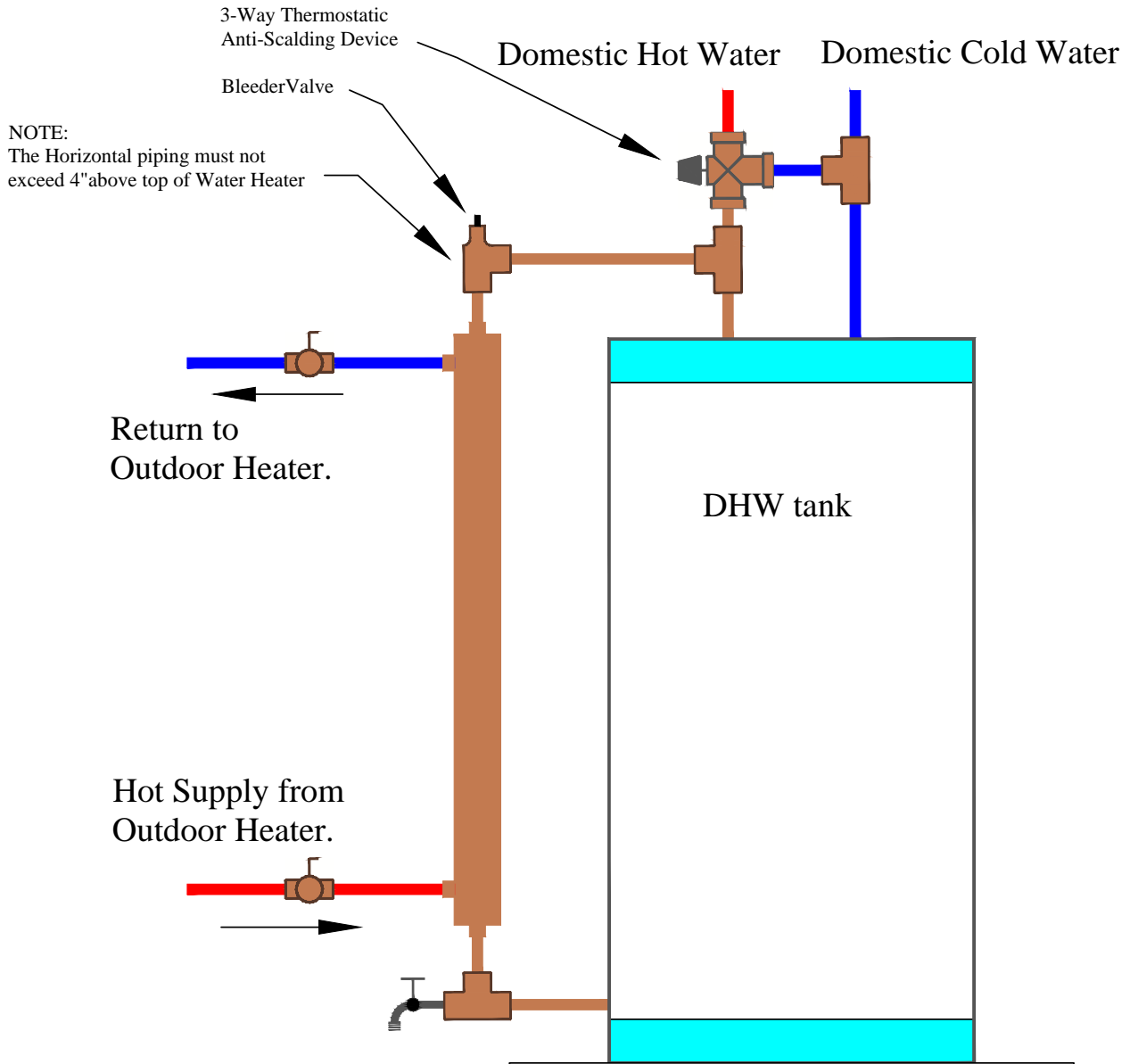

NOTE:  
The Horizontal piping must not exceed 4" above top of Water Heater

NOTE:  
It is recommended that water heater is raised on a stand to get maximum length of side arm heater.

NOTES:  
Installer must comply with all applicable codes and regulations.  
For illustration purposes only.

# Hot Water Tank Side Arm and Existing Furnace Installation Example

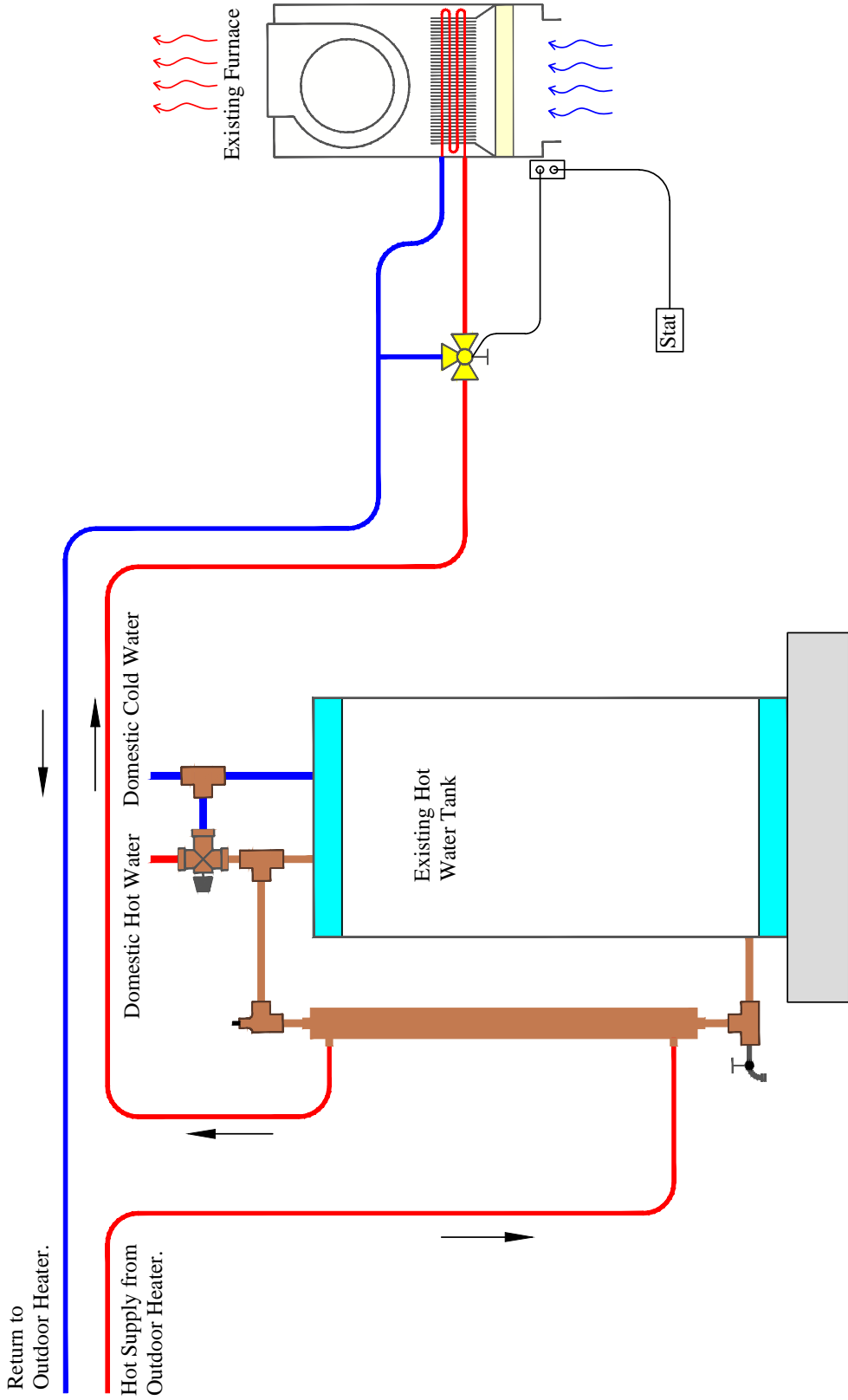

NOTES:  
 Installer must comply with all applicable codes and regulations.  
 For illustration purposes only.



**Polar Furnace Mfg. Inc.**  
**Box 157**  
**Sperling, Manitoba**  
**R0G 2M0**

ph: 1.204.626.3381

f: 1.204.626.3326

e: [support@polarfurnace.com](mailto:support@polarfurnace.com)



**POLAR**  
**FURNACE**  
clean, simple heating with wood