

# Installation & Operating Manual

## The Harman SF 250 Coal Stove



We suggest that our hearth products be installed and serviced by professionals who are certified in the U.S. by the National Fireplace Institute (NFI) as NFI Specialists.



R2

### SAFETY NOTICE

READ THIS ENTIRE MANUAL BEFORE YOU INSTALL OR OPERATE YOUR HEARTH. FAILURE TO FOLLOW THESE INSTRUCTIONS MAY RESULT IN PROPERTY DAMAGE, PERSONAL INJURY, OR EVEN DEATH.

FOR INFORMATION ONLY: CANADA: NOT BUILT TO MEET CANADIAN STANDARDS.

THIS HEARTH STOVE IS NOT PROPERLY INSTALLED IF A WARNING LABEL ON THE FRONT PANEL IS FOLLOWING THESE INSTRUCTIONS.

CONTACT YOUR LOCAL BUILDING OR FIRE OFFICIALS ABOUT RESTRICTIONS AND PERMITS AND INSPECTION REQUIREMENTS IN YOUR AREA.

CONTACT YOUR LOCAL AUTHORITY (SUCH AS THE POLICE, FIRE DEPARTMENT, FIRE DEPARTMENT, FIRE DEPARTMENT, ETC.) TO OBTAIN THE NECESSARY PERMITS.

SEE THE GUIDE TO UTILISATION OF HEARTH STOVES FOR MORE INFORMATION. CONTACT HARMAN STOVE COMPANY.

SAVE THESE INSTRUCTIONS.

Page 2 of 10 70733



## TABLE OF CONTENTS

Safety Considerations .....	4
Assembly .....	5
Installation .....	6
Chimney & Venting .....	7
Operating Instructions .....	9
Preventative Maintenance .....	10
Optional Hot Water Coil .....	11
Warranty .....	13
Testing Label .....	14

# SAFETY CONSIDERATIONS

## CAUTION

- **Keep Children Away**
- **May Cause Serious Burns**
- **All Surfaces of stove are hot. Do not touch.**
- **Keep children away.**
- **Serious burns will result if touched.**

## Fuel/Firing Warnings

### Danger

**Do not use chemicals or fluids to start or "freshen up" a fire. Severe body burns or a fire in your home could result.**

**Do not burn garbage, gasoline, thinners, drain oil or engine oil, kerosene, or fuel oil, etc. An explosion, a house fire, or personal injury could result. Keep all such liquids well away from the stove while in use.**

**Never burn materials other than coal. A chimney fire or heat exchanger failure could result. This includes large amounts of corrugated boxes, wood shavings, paper scraps, garbage or other burnable materials.**

**If chimney pipes or connectors reach 500 degrees fahrenheit (maximum temperature), the stove is being over-fired. We recommend the purchase of a Magnetic Temperature Gauge to monitor the stove and stack temperatures relative to the amount of draft the customer permits the stove to operate.**

**It has been verified that creosote will ignite at 650 degrees fahrenheit. It is the owner's responsibility to follow these recommendations.**

**This stove consumes air when it is burning. If your house is tightly sealed and insulated, it is advisable that a window in the vicinity be opened slightly while the stove is burning. Information contained in this manual is manufacturer's recommendations and if there is any difference between our recommendations and local code requirements, we suggest following local code requirements.**

## Curing Paint

During the first few hours of burning, a blue smoke will be observed rising from the painted surface of the stove. It is advisable to increase the amount of fresh air (open window) in the room during this breaking-in period. Do not be alarmed, this is normal and does not cause harm.

## Mobile Homes

This Harman Stove is not approved for installation in mobile/manufactured homes.

**SPECIAL WARNING: NEVER OPERATE YOUR STOVE WITH THE FIRE OR ASH DOOR OPEN!**

## Keep Ash Pan Empty.

Excessive ash buildup will block the airflow around the grates. This, and only this, will cause the grates to warp and sag. Neglect is not covered by your stove's warranty.

# ASSEMBLY

## Blower

The blower slides into the channel bracket on the rear of the stove as shown at right. Plug the blower into a properly grounded receptacle.

## Shaker Handle

The shaker handle installs onto the shaker handle mount using the two hex-bolts and washers provided.

## Firebricks

The SF250 uses 14 "standard" firebricks, as shown below. These standard firebricks measure 9" X 4½" X 1¼" each. The firebricks are already installed in the stove but can be removed to lighten the stove for moving. The doors can also be removed by simply lifting them off of the hinges.

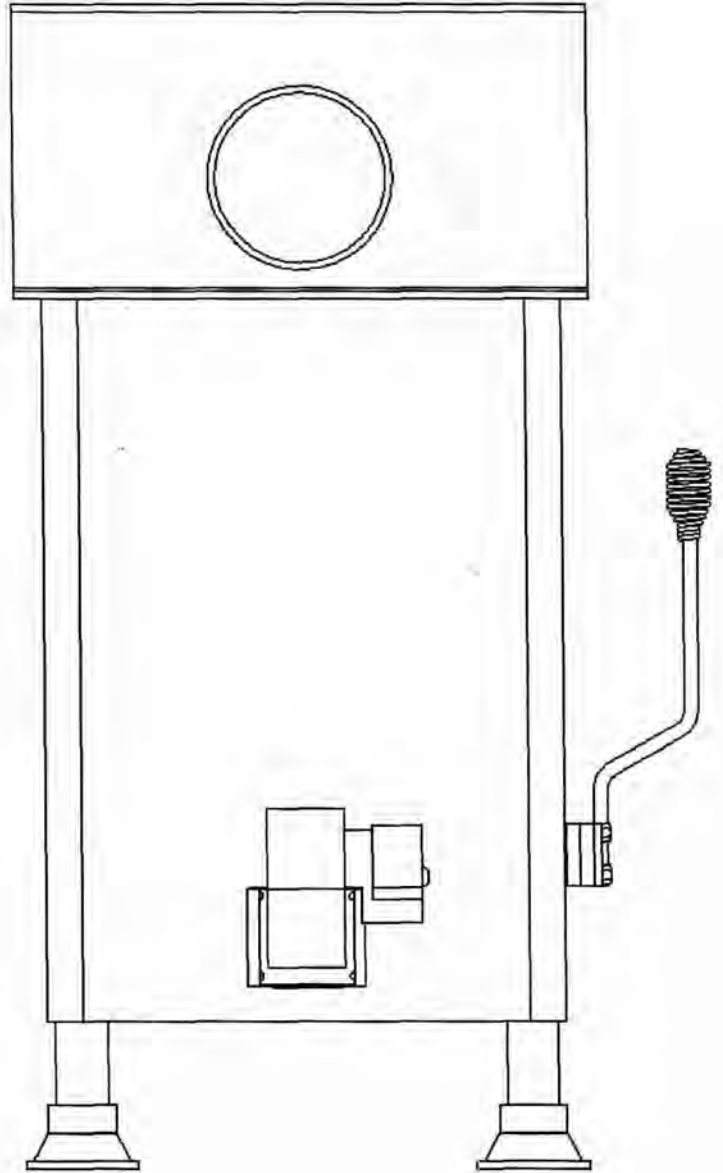

**Firebrick Diagram**

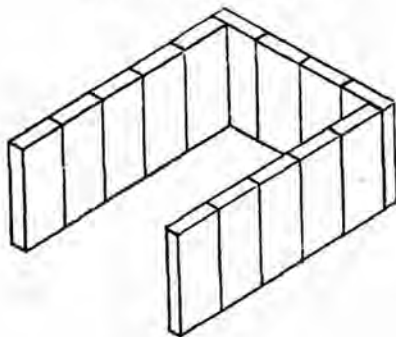

# INSTALLATION

**WARNING:** This stove must be installed in accordance with all state and local building code requirements.

## Locating the stove

Locate the stove as close to the chimney or flue as possible, while still maintaining the clearances to combustibles.

Locate the stove where there is sufficient air supply for ventilation and proper combustion.

## Clearance to Combustibles

Safe stove clearance to combustible walls is 24" to the rear and 36" to the sides and front. Do not place furniture and the like directly in front of the stove.

## Floor Protection

Floor protection for a combustible floor should consist of 3/8" millboard or a stove board providing equal protection ( $k=.84$ ,  $R=.45$ ). The floor protection should extend 8" to the rear and either side and 16" in front of the stove. The floor protection should also extend 2" to either side of the chimney connector, to the wall where the connector enters the flue.

## Adjustable Leveling Feet

To accommodate an un-even hearth surface, the SF250 is equipped with adjustable leveling feet. Each foot can be turned in or out of the leg to lower or raise that corner of the stove.

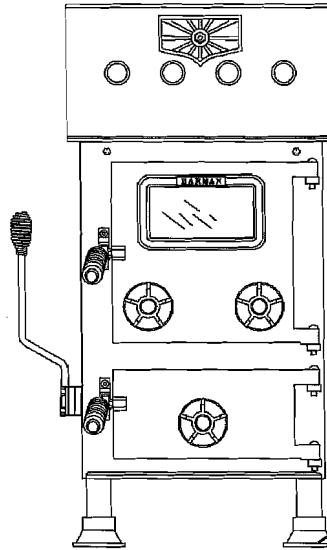

Turn the round foot in or out to level each corner of the stove.

It is recommended that you have your unit installed and serviced by professionals who are certified by the National Fireplace Institute (NFI) as NFI Specialists.

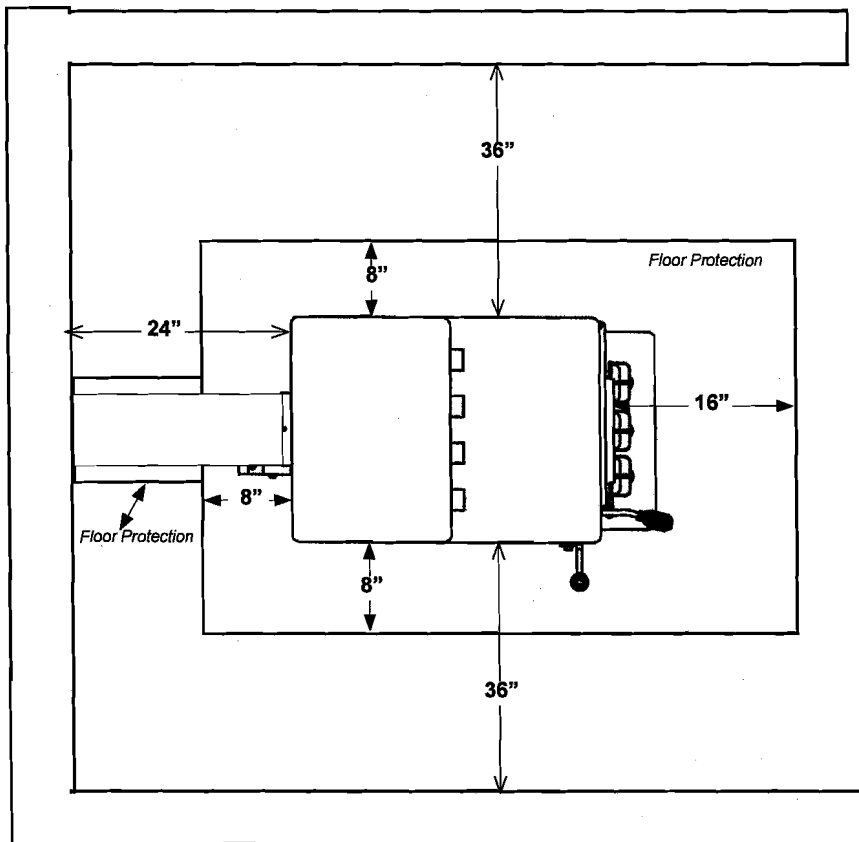

# CHIMNEY & VENTING

## Types Of Chimneys

The chimney is one of the most important, yet most neglected and misunderstood portions of any solid fuel burning stove installation. Do not connect this stove to a chimney flue serving another heating device.

**THE STOVE MUST BE CONNECTED TO ITS OWN TILE-LINED FLUE. A MINIMUM FLUE SIZE OF 8" X 8" IS NECESSARY FOR PROPER OPERATION.**

**UNDER NO CIRCUMSTANCES SHOULD A MANUAL FLUE DAMPER BE INSTALLED IN THE SMOKE PIPE BETWEEN THE STOVE AND THE CHIMNEY.**

**NO DAMPER, HEAT SAVER OR AUTOMATIC VENT DAMPER DEVICE SHOULD BE INSTALLED IN OR ON THE SMOKE PIPE.**

**CAUTION: THE CHIMNEY MUST BE A CLASS "A" CHIMNEY, IN GOOD OPERATING AND CLEAN CONDITION.**

**NOTE: THE USE OF ALUMINUM TYPE "B" GAS VENT FOR SOLID FUELS IS UNSAFE AND PROHIBITED BY THE NATIONAL FIRE PROTECTION AGENCY CODE.**

### There are three types of class "A" chimneys:

1. Masonry with tile liner, to include brick or stone. It must be supported on grade level foundation.
2. Insulated, manufactured chimney, listed or certified by a national test agency.
3. Triple-wall metal class "A" chimney, listed or certified by a national test agency.

If your masonry chimney has not been used for some time, have it inspected by a qualified person. If a listed or certified manufactured chimney is to be used, make certain it is installed in accordance with the manufacturer's instructions and all local and state codes.

The minimum recommended height for solid fuel chimneys is 16 feet from the stove collar. The chimney must be two feet higher than anything within ten feet. It also must extend three feet above the point where it intersects or exits the roof line.

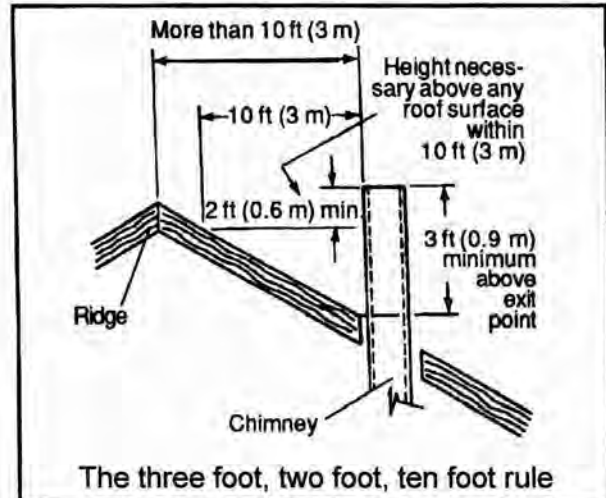

In order to have a properly operating solid fuel heating system, the chimney must be capable of providing the necessary draft. The minimum required draft is .06 inches of water column (W.C.). This must be measured using a draft gauge. If the chimney cannot supply this constant draft, the stove will not operate properly. A barometric damper may be used and properly adjusted to compensate for excessive draft only.

**IMPORTANT:** When you measure the the draft, the stove must be operating with sufficient time given for the stove and chimney to warm. Burn for at least thirty minutes. The draft reading is best taken 18" up from the center of the flue outlet, in the connector pipe. Drill a hole in the pipe for the meter tube, and fill it with a screw or silicone when done with the test.

**IMPORTANT:** The connector pipe must be 24 gauge or thicker.

When connecting the flue pipe to the stove, the first section should be installed inside the stove collar. It should be secured to the collar with, at least, three screws or rivets.

Do not pass the connector pipe through a wall or ceiling without first checking with your local codes. If allowed, use only approved pass-thru methods.

**NOTE:** All horizontal runs of venting should have a 1/4 inch of rise per foot of length.

Use no more than two 90° elbows in the connector. If a barometric damper is needed, to compensate for excessive draft, install it only in a vertical section of vent pipe.

# CHIMNEY & VENTING

## **Possible causes of insufficient draft;**

**A. Chimney Leaks** - Air leaking in around a loose fitting cleanout door, flue pipe joints and/or seams not secured, improper plug openings or defective masonry.

**B. Chimney Too Short** - The general rule for chimneys; 16 feet tall, three feet above the roof exit, and two feet taller than anything within ten feet.

**C. Blocked Chimney** - Have the chimney cleaned and inspected prior to installation and before each heating season.

**D. Trees Or Other Topographical Barriers** - Impeding on the chimney's operation or causing a down draft situation. This can also be caused by adjacent buildings or another roof of the same structure giving air currents a downward swirl.

**NOTE:** The chimney on the illustrated house is too low, it should be raised to compensate for down draft potential.



dimensions of the liner be at least as large as the appliance flue outlet and no larger than 125% of the collar for a round flue. An example, a 8" flue collar is 50 square inches. Increased by 25% would be 63 square inches, or approximately a 9" round flue. In general for round liners, it is recommended that they not be increased by more than one inch from that of the stove collar. This will help ensure proper draft with the lower flue temperatures.

**REMEMBER;** A solid fuel burning stove can only perform as well as its venting system will allow it to.

THE MOST IMPORTANT THING TO REMEMBER ABOUT CHIMNEYS IS THEIR NEED FOR MAINTENANCE AND CLEANING. IF A CHIMNEY IS NOT CLEANED ON A FREQUENT BASIS, IT WILL AFFECT THE DRAFT AS WELL AS BEING A CONTRIBUTING CAUSE TO A POSSIBLE CHIMNEY FIRE.

## **IF YOU HAVE A CHIMNEY FIRE:**

1. GET EVERYONE OUT OF THE HOUSE.
2. CALL THE FIRE DEPARTMENT.
3. CLOSE THE DRAFT CONTROL KNOBS ON THE STOVE.

DO NOT USE THE CHIMNEY UNTIL IT HAS BEEN THOROUGHLY CLEANED AND INSPECTED BY A QUALIFIED PERSON.

**E. Chimney Size** - The chimney can not be smaller than the flue exit from the appliance. Too large of a chimney could stay too cool to promote adequate draft.

**F. Chimney Offsets** - Offset chimneys should be avoided. The offset area can collect debris and cause a blockage.

**G. Elbow restrictions** - There should be no more than two 90° elbows or the equivalent used in connecting the stove to the chimney flue.

**H. Shared Flue** - No more than one appliance shall vent into a single flue.

The most common cause of poor draft is an improperly sized flue liner. It is recommended that the inside

# OPERATING INSTRUCTIONS

**The SF250 is approved for use with coal only. Burning wood or other such fuels in this stove, except for the purpose of igniting a coal fire, is prohibited.**

## **Starting A Fire**

Begin by opening the draft control knobs on both the load door and the ash door. Open both doors. Be sure all items have been removed from the ash pan (i.e. touch-up paint, warranty registration, etc...) Place approximately eight sheets of newspaper, crumpled, on top of the grates. Lay some kindling on top of the crumpled paper. This kindling should be dry and no larger than 3/4 in. diameter. It should be layered in a criss-cross fashion to allow good air flow. Now place some slightly larger pieces of wood (about 2" diameter) on top of the kindling. Using a match or grill lighter, ignite the paper at the bottom just inside the door. Close both doors and allow the the kindling and larger wood to catch fire. After around five minutes, open the load door slightly, for a few seconds and then open completely. This is a good practice to get into as it will allow any smoke and gases to clear away from the door opening. Add small compact pieces of wood when the kindling is burning hot. When a substantial bed of hot wood coals is established, start adding coal in small amounts at a time. Allow a few minutes between coal loadings to be sure that what you've added is ignited. You can keep the ash door open through this process, but **NEVER LEAVE THE STOVE UNATTENDED WITH A DOOR OPEN**. Once you have a bed of burning coal, you can load coal into the stove to the top of the firebricks. Always make sure there is some flame showing through the coal. This will ensure the gases are being burned and not accumulating in the firebox. After a good coal ignition, set the draft controls on the load door to about 1/4 turn open. The draft control on the ash door is used to control the rate of burn. After starting a fire, keep it about 2 full turns open for about 30 minutes. Then, adjust further closed to the proper output level. Normal operation will be between cracked and one turn open. Since coal responds slowly to draft adjustments, make only small adjustments and allow time in between.

## **Loading**

Coal should only be added when there is a reasonably hot fire. The coal bed should be bright and vigorous. If the fire is burning hot and there is a deep bed of coals, full loads can be added. If it is not as described, add coal in small batches only.

## **Increasing Heat From A Low Fire**

Every effort should be made not to let a coal fire burn so long that it has started to die. This will cause the reloading process to be much longer, and there is a good possibility of losing the fire.

Do not shake or stir a low fire.

Open the draft control all the way until the fire gets as hot as possible. Start adding small batches of coal and follow the instructions for starting a fire.

Once there is a good bed of burning coals, the grates may be shaken to remove ashes.

## **Shaking Ashes**

Shaking should be done only when there is a hot fire burning. The frequency of shaking will depend on the degree of burning. Shaking should be done at least once per day, preferably twice.

The best results from shaking will occur when short choppy strokes are used, rather than long, even strokes. Grasp the shaker handle with one hand and shake it, only moving the actual handle 1/2 inch or less. Do this until you start to see hot coals falling into the ash pan, then stop. Do not rock the grates, as this will allow burning coal to fall through, and you'll lose the fire.

## **Ashes**

The ashes should never be allowed to accumulate in the ash pan. Excess ash will block the required airflow through the grates and cause them to warp and sag.

Neglect is not covered by your stove's warranty.

**Ashes should be placed in a metal container with a tight fitting lid. This closed container of ashes should be placed on a noncombustible floor or on the ground, well away from any combustible materials, pending final disposal. If the ashes are disposed of by burial in soil, or otherwise locally dispersed, they should be retained in the closed container until all cinders have thoroughly cooled.**

## **Fuel**

The SF250 is approved for burning anthracite coal. Pea, Nut, and Stove sized coal are all suitable.

## **Grates**

The functions of a grate system are to support the fuel load, while allowing air flow to the fire in a balanced amount. Another function is to allow for ash removal without losing the fire. The SF250 grate system provides for all of this and can be removed with no tools required.



# MAINTENANCE

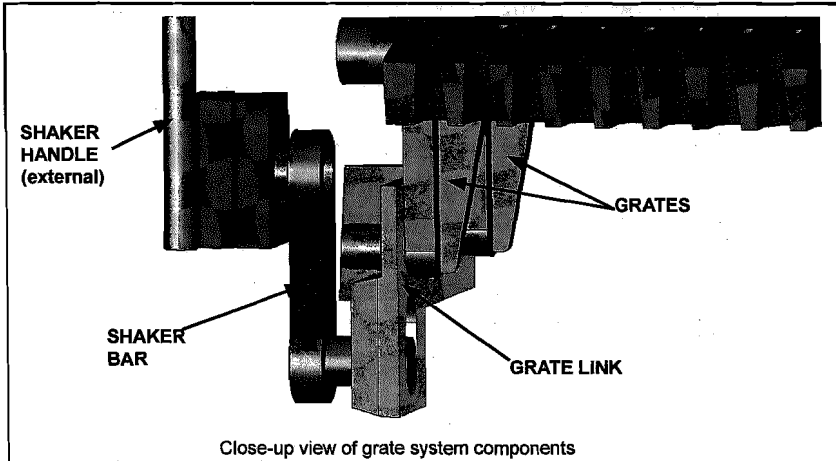

## Periodic and Normal Everyday Maintenance

Blower Motor- Oil twice yearly.

Grates- Keep ash pan empty.

**CAUTION: BEFORE CLEANING THE CHIMNEY AND SMOKE PIPE, BE SURE THE FIRE IS OUT AND THE STOVE IS COOL.**

Avoid Chimney Fires. On a regular schedule, check for creosote and soot buildup in the chimney, smoke pipe, and spiral chamber. These areas must be kept clean. Keep a professional chimney sweep in mind.

Steel brushes are the safest for cleaning metal surfaces. Salt solutions and some chemical cleaners may damage the flue liner.

To clean the chimney, obtain a stiff brush with an extendable handle. Insert the brush into the chimney from the top. Continue brushing and sweeping downward until the entire length of the chimney is cleaned. After cleaning the chimney, any debris will be at the bottom by the clean-out door. Open the clean-out and vacuum the loose debris.

Clean the smoke pipe, from the chimney to the stove, using a metal brush.

Cleaning of the spiral chamber - Remove clean-out plate from the front of the stove. Using a 3/4" wrench, loosen the clean-out bolt approximately 2 turns. Slide the clean-out plate to one side and remove it from the opening. Scrape the spiral chamber with a putty knife or similar tool. The residue will fall down to the bottom of the chamber and can be removed through the flue opening on the back of the stove by means of a vacuum cleaner or a small scoop.

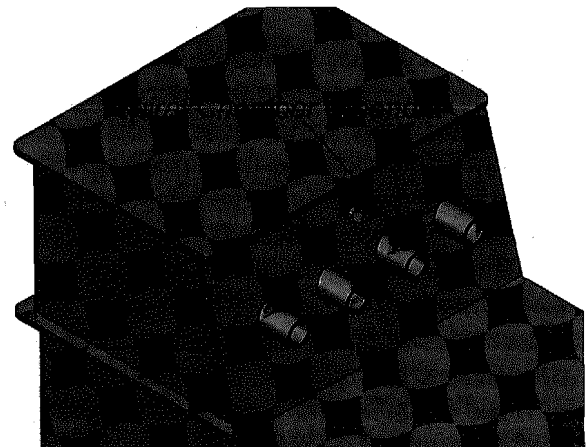

In the firebox, remove all ashes and vacuum the entire firebox. Inspect and replace any cracked firebricks. Since coal and coal ashes will draw moisture, it is important to thoroughly clean the firebox at the end of the heating season. Some users apply a thin coating of oil or other rust inhibitor to the inside workings, over the summer. The main thing is that you remove all of the ash.

# WATER COIL OPTION

## Water Coil Installation

Use a hole saw and the template supplied with the coil to make two holes through the side wall of the stove. Keep the coil holes above the firebrick, and away from the loading door. Place one of the supplied nuts on each leg of the coil. Place the coil through the holes in the stove, and adjust the nuts so that the pipes stick out about 1¼" to 1½" from the sidewall of the stove. Put flat washers and nuts on the outside, and tighten within ¼ inch. Place fiberglass gasket around each pipe at the washers and tighten securely. You are now ready to run pipes according to one of the following examples.

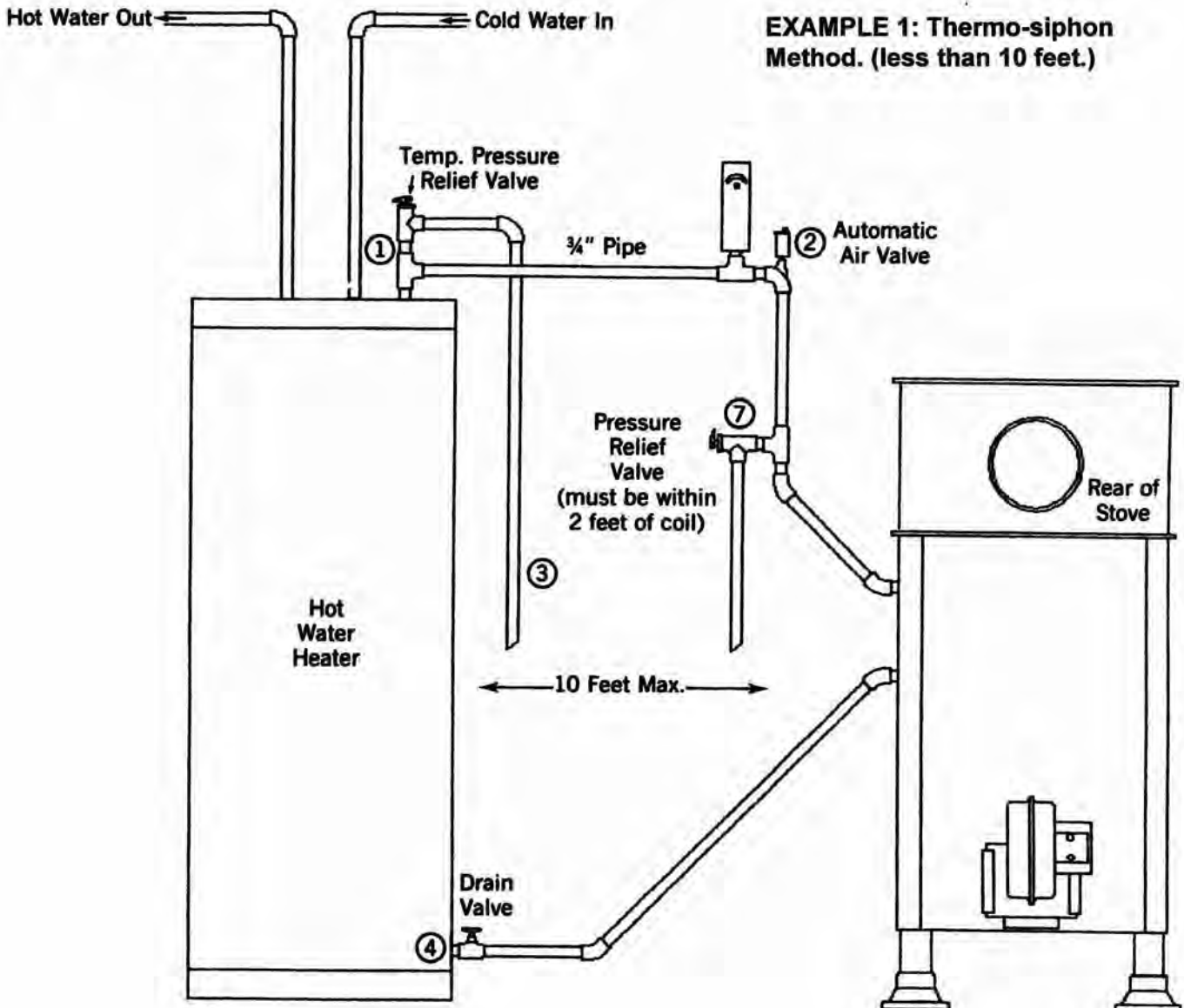
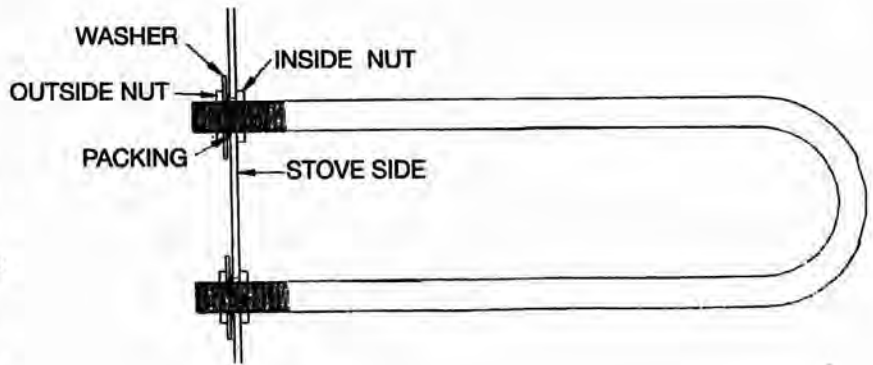

# WATER COIL OPTION

**Example 1: Thermo-siphon Method.** This is the simplest and most economical method, providing the existing water heater (storage tank) is within 10 feet of the stove. The water inlet, where the Temp/Pressure relief valve is located, must be higher than the top leg of the water coil. The storage tank should be elevated, if necessary, to allow for proper thermo-siphon action.

- A). Turn off the water heater and the water supply to it. Drain the tank completely.
- B). Remove the Temp/Pressure relief valve and discard. Install a short  $\frac{3}{4}$ " nipple and tee (1) along with a new Temp/Pressure relief valve.
- C). Run  $\frac{3}{4}$ " copper tubing, along with the necessary fittings, between the storage tank and the top leg of the coil. Install a  $\frac{3}{4}$ " vent elbow and automatic "float type" air vent (2) in the high point of the line. Within two feet of the top leg of the coil, install a 150 lb. pressure relief valve (7). Run  $\frac{3}{4}$ " tubing from the release exit of both relief valves, downward (3) so that the hot water may escape in the event of over-heating.
- D). Remove the drain valve, at the bottom of the storage tank. Install a  $\frac{3}{4}$ " nipple and tee, and reinstall the drain valve to the tee (4). Run  $\frac{3}{4}$ " copper tubing, with the necessary fittings, between the drain/tee combination and the lower leg of the coil.

After all of the connections are completed, you can refill the tank. Restore power to the water heater ONLY after the tank has been completely refilled.

## EXAMPLE 2: Circulator Method. (more than 10 feet.)

**Example 2: Circulating pump method.** Used when the distance is more than ten feet or when the stove is on a higher level than the existing water heater. In addition to a circulator, you may want to add a aquastat to control the pump according to water temperature. This is not necessary if the circulator is left run continuously. Another option is a gate valve placed near the circulator to control the rate of flow.

- A). Turn off the water heater and the water supply to it. Drain the tank completely.
  - B). Remove the Temp/Pressure relief valve and discard. Install a short  $\frac{3}{4}$ " nipple and tee (1) along with a new Temp/Pressure relief valve.
  - C). Remove the drain valve, at the bottom of the storage tank. Install a  $\frac{3}{4}$ " nipple and tee, and reinstall the drain valve to the tee (4).
  - D). Install a circulating pump (6) as shown. Run  $\frac{3}{4}$ " copper tubing from the circulator to the lower leg of the coil. This is where the optional gate valve (5) can be installed.
  - E). Install a  $\frac{3}{4}$ " tee and a 150 lb. pressure relief valve (7) in the top leg within 2 feet of the top outlet of the water coil.
  - F). Complete the copper line by running it back to the tee at the top of the water tank, making sure to install a vent elbow and automatic air vent (2) at the high point of the line. The optional aquastat can be installed in this line a maximum of six feet from the stove. The aquastat must be a "close on temperature rise" type and must be wired and set to turn on the circulator when the water temperature reaches 120° Fahrenheit.
- The system is now ready to be refilled and power restored to the water heater ONLY after the tank is filled.

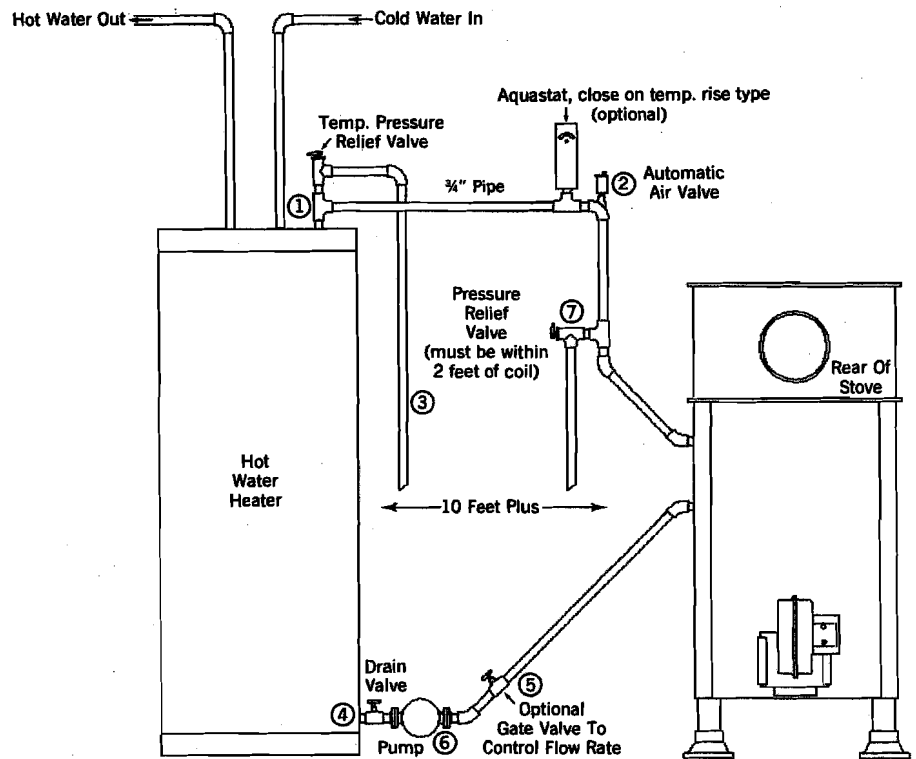

# WARRANTY

## **HARMAN GOLD WARRANTY 6 YEAR TRANSFERABLE LIMITED WARRANTY (Residential) 1 YEAR LIMITED WARRANTY (Commercial)**



Harman Stove Company warrants its products to be free from defects in material or workmanship, in normal use and service, for a period of 6 years from the date of sales invoice and for mechanical and electrical failures, in normal use and service, for a period of 3 years from the date of sales invoice.

If defective in material or workmanship, during the warranty period, Harman Stove Company will, at its option, repair or replace the product as described below.

The warranty above constitutes the entire warranty with respect to Harman Stove Company products. HARMAN STOVE COMPANY MAKES NO OTHER WARRANTY, EXPRESSED OR IMPLIED, INCLUDING "ANY" WARRANTY OF MERCHANTABILITY, OR WARRANTY OF FITNESS FOR A PARTICULAR PURPOSE. No employee, agent, dealer, or other person is authorized to give any warranty on behalf of Harman Stove Company. This warranty does not apply if the product has been altered in any way after leaving the factory. Harman Stove Company and its agents assume no liability for "resultant damages of any kind" arising from the use of its products. In addition, the manufacturer and its warranty administrator shall be held free and harmless from liability from damage to property related to the operation, proper or improper, of the equipment.

**THERE ARE NO WARRANTIES WHICH EXTEND BEYOND THE DESCRIPTION ON THE FACE HEREOF.**

**THESE WARRANTIES APPLY** only if the device is installed and operated as recommended in the user's manual.

**THESE WARRANTIES WILL NOT APPLY** if abuse, accident, improper installation, negligence, or use beyond rated capacity causes damage.

**HOW TO MAKE A CLAIM** - Any claim under this warranty should be made to the dealer from whom this appliance was purchased. Then contact is made with manufacturer, giving the model and serial numbers, the date of purchase, your dealer's name and address, plus a simple explanation of the nature of the defect. Extra costs such as mileage and overtime are not covered. Nuisance calls are not covered by these warranties.

**THIS WARRANTY IS LIMITED TO DEFECTIVE PARTS - REPAIR AND/OR REPLACEMENT AT HARMAN STOVE COMPANY'S OPTION AND EXCLUDES ANY INCIDENTAL AND CONSEQUENTIAL DAMAGES CONNECTED THEREWITH.**

**WARRANTY EXCLUSIONS:** Failure due, but not limited to, fire, lightning, acts of God, power failures and/or surges, rust, corrosion and venting problems are not covered. Damage and/or repairs including but not limited to; remote controls, filters, fuses, knobs, glass, ceramic brick panels, ceramic fiber afterburners, door packing, tile, ceramic log sets, paint, batteries or battery back-up and related duct work are not covered. Also excluded from this warranty are consumable or normal wear items including but not limited to; flame guides, grates, coal bars, afterburner hoods, fire brick, gaskets. Additional exclusions for corn stoves are burnpot housing weldment, burnpot grate weldment (pellet or corn), burnpot front plate (pellet or corn), burnpot front plate lock, corn auger extension, grain caps, ceramic insert, and ceramic insert plate. Additional or unusual utility bills incurred due to any malfunction or defect in equipment and the labor cost of gaining access to or removal of a unit that requires special tools or equipment are not covered. Maintenance needed to keep the stove in "good operating condition" is not covered. This includes, but is not limited to, cleaning, adjustment of customer controls and customer education. Labor, materials, expenses and/or equipment needed to comply with law and/or regulations set forth by any governmental agencies are not covered.

This Warranty provides specific legal rights and the consumer may have other rights that vary from state to state.

In the event of change in ownership, the remaining portion of this warranty may be transferred to the new owner by sending the new owner information and a transfer fee of \$25.00 US to the Harman Stove Company.

**PLEASE READ THE LITERATURE BY THE MANUFACTURER FOR THE VARIOUS ACCESSORY DEVICES. THE MANUFACTURER WARRANTS THESE ACCESSORY DEVICES, NOT HARMAN STOVE COMPANY OR THEIR WARRANTY ADMINISTRATOR. FURTHERMORE, THESE ACCESSORY DEVICES MUST BE INSTALLED AND USED ACCORDING TO THE RECOMMENDATIONS OF THE MANUFACTURER.**

**REMEDIES** - The remedies set forth herein are exclusive and the liability of seller with respect to any contract or sale or anything done in connection therewith, whether in Contract, in tort, under any warranty, or otherwise, shall not, except as herein expressly provided, exceed the price of the equipment or part of which such liability is based.

**CLARIFY** - The above represents the complete warranty, which is given in connection with stoves, manufactured by Harman Stove Company. No other commitments, verbal or otherwise, shall apply except by a written addendum to this warranty.

# TESTING LABEL



## LISTED SOLID FUEL ROOM HEATER

MODEL: SF 350   
 SF 250   
 SF 150

TESTED TO UL 1482, AUGUST 1981

DO NOT REMOVE OR COVER THIS LABEL

WHI-

### MINIMUM CLEARANCES TO COMBUSTIBLE MATERIALS:

A.	UNIT TO SIDEWALL	36"
B.	UNIT TO BACKWALL	24"
C.	CHIMNEY CONNECTOR TO SIDEWALL	44"
D.	CHIMNEY CONNECTOR TO BACKWALL	18"
E.	FLOOR PROTECTOR, SIDE AND REAR	8"
H.	FLOOR PROTECTOR, FRONT	16"

CHIMNEY CONNECTOR TO COMBUSTIBLES 18" MINIMUM  
 FLOOR PROTECTION: UNIT MUST BE PLACED ON NON-COMBUSTIBLE FLOOR OR USE A 3:8 ASBESTOS MILLBOARD PROTECTOR OR EQUIVALENT EXTENDING OUT 8" TO THE SIDE AND REAR, 16" IN FRONT

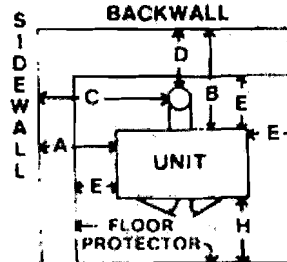

USE CLASS "A" CHIMNEY & CLASS "A" 7 IN. CHIMNEY CONNECTOR. SPECIAL METHODS ARE REQUIRED WHEN PASSING THROUGH A COMBUSTIBLE WALL OR CEILING. SEE INSTRUCTIONS AND LOCAL BUILDING CODES.

INSTALL AND USE ONLY IN ACCORDANCE WITH THE MANUFACTURER'S INSTRUCTIONS AND LOCAL BUILDING CODES. CONTACT LOCAL BUILDING OR FIRE OFFICIALS ABOUT RESTRICTIONS AND INSTALLATION INSPECTION IN YOUR AREA.

FUEL: COAL

ELECTRICAL RATING: 115 VOLTS, 2 AMPS, 60 HZ.

DO NOT OBSTRUCT SPACE UNDER HEATER.

KEEP DOORS CLOSED WHILE IN OPERATION.

**DO NOT CONNECT THIS UNIT TO A CHIMNEY FLUE SERVING ANOTHER APPLIANCE.**

PREVENT HOUSE FIRES.

CHIMNEY CONNECTOR 7" X 24" G PIPE.

DO NOT OVERFIRE - IF FIREPLACE STOVE OR CHIMNEY CONNECTOR GLOWS, YOU ARE OVERFIRING. INSPECT AND CLEAN CHIMNEY FREQUENTLY. UNDER CERTAIN CONDITIONS OF USE, CREOSOTE BUILDUP MAY OCCUR RAPIDLY.

HARMAN STOVE AND WELDING, INC.  
 352 MTN. HOUSE ROAD  
 HALIFAX, PA 17032

