

Z-VENT

MODEL SVE SERIES III **INSTALLATION AND MAINTENANCE** **INSTRUCTIONS**

3" & 4"

SPECIAL STAINLESS STEEL VENTING SYSTEM
FOR GAS BURNING APPLIANCES
CATEGORY I, II, III, & IV



TESTED AND LISTED BY
UNDERWRITERS LABORATORIES INC.
UL 1738 & BH636

Note the following before installation of Z-Vent

- * Examine all components for possible shipping damage prior to installation. *
- * The Z-Vent system must be free to expand and contract. Pipe must be properly supported. *
- * Proper joint assembly is essential for a safe installation. Follow these instructions exactly as written. Check severeness of joints upon completion of assembly. *
- * Check for unrestricted vent movement through walls, ceilings and roof penetrations. *
- * Different manufacturers have different joint systems and adhesives. Do Not Mix Pipe, Fittings or Joining methods from different manufacturers. *

FLEXMASTER CANADA LTD
452 ATTWELL DR.
M9W 5C3
ETOBICOKE, ONTARIO
(416) 679-0045

Z-FLEX US, INC.
20 COMMERCE PARK, NORTH
BEDFORD, N.H.
03110-691
1(800) 654-5600

Visit our web site at www.z-flex.com

SPECIAL STAINLESS STEEL VENTING

For use with Category I, II, III, IV appliances

Contact Local Building or Fire Officials about Restrictions and Installation Inspections in your area as well as National codes: USA - National Fuel Gas Code ANSI-Z223.1/NFPA 54, CANADA -CAN\CGA-B149.1 or .2 Fuel Burning Installation Code

Please refer to appliance manufacturers' instructions to determine proper sizing and connection of venting system to appliance, including maximum horizontal length, maximum height, and installation clearances (air spaces). The proper operation of the vent system and appliance requires parts specified by Z-FLEX with no deletions or substitutions.

Z-FLEX recommends that an experienced professional who works with venting systems on a regular basis perform the installation. These instructions are intended as a guide to assist a professional installer.

When the Z-VENT system is installed, the following should be observed:

1. A venting system that exits the structure through a sidewall or the like, shall terminate not less than 12 inches (254 mm) above the ground (see illustration # 2, page 4).
2. The termination of a system shall be located above the snow line in geographical areas where snow accumulates. The termination area should be kept clear of snow and ice at all times.
3. The vent shall not terminate less than 7 ft. (2.13 m) above a paved sidewalk or driveway.
4. The termination shall be 6 ft. (1.8 m) or more from the combustion air intake of any appliance.
5. The system shall terminate more than 3 ft. (.91 m) from any other building opening, gas utility meter, service regulator or the like.
6. Exterior mounted venting systems should be enclosed below the roof line with a chase to limit condensation and protect against mechanical failure.

NOTES:

A. The Z-FLEX SPECIAL STAINLESS VENT SYSTEM is for use only with appliances having a positive vent pressure of 8" of water column or less.

B. Except for installation in one and two family dwellings, a venting system that extends through any zone above that on which the connected appliance is located shall be provided with an enclosure having a fire resistance rating equal to or greater than that of the floor or roof assemblies through which it passes

C. Do not place any type of insulation in any required air spaces surrounding the venting system.

D. A termination must be used on all installations to assure proper operation and to prevent debris from entering the venting system.

E. Vertical runs must use firestops as lateral support at each ceiling level and at least one support collar at the base of the vertical run. For vertical runs exceeding 16' (4.88 m), a support collar is required at 16' (4.88 m) intervals. Horizontal runs require a loose fitting metal strap or similar support at each joint.

JOINT PROCEDURE
(see illustration #1 below)

The female end of each Z-Vent III component incorporates a silicone sealing gasket. Examine all components to insure that gasket integrity has remained during shipping. Gaskets must be in the proper position or flue gases could leak resulting in carbon monoxide poisoning.

1. Align pipes and push them together as far as they will go (to indent or at least 1.75 inches).
2. Tighten gear clamp to a minimum torque of 40 in/lbs. and a maximum of 50 in/lbs. Gear Clamp is not required on 6" system.

NOTE: Some flue collars may require the use of high temperature silicone sealant to make a positive pressure gas tight seal.

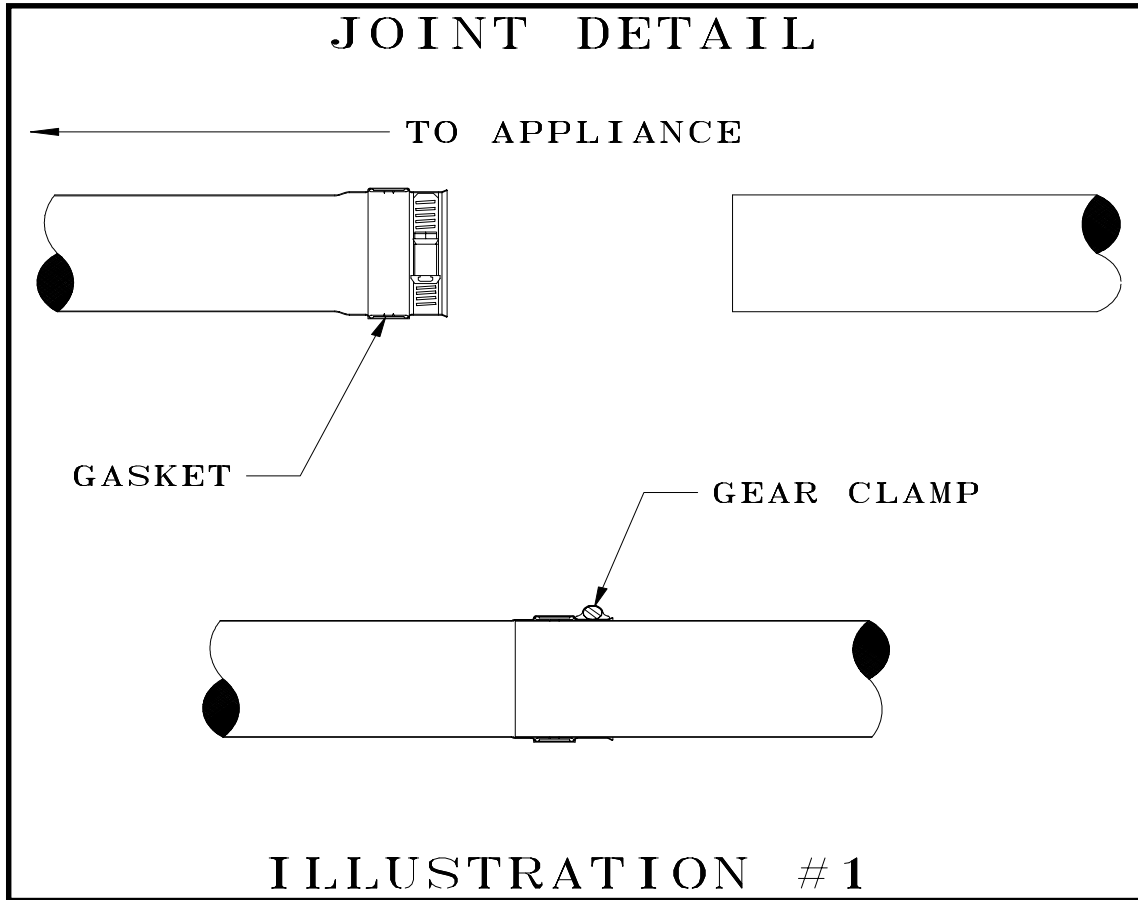

CLEARANCE TO COMBUSTIBLES

SYSTEM OPERATING TEMPERATURE	CLEARANCE ENCLOSED		CLEARANCE UNENCLOSED	
	HORIZONTAL	VERTICAL	HORIZONTAL	VERTICAL
300°F (149°C)	8" (200 mm)	4" (100 mm)	1" (25 mm)	1" (25 mm)
480°F (249°C)	8" (200 mm)	4" (100 mm)	1" (25 mm)	1" (25 mm)

SIDE WALL VENTING INSTALLATION

(see illustration #2 below)

1. Penetrating a combustible wall requires the use of a wall thimble. The pipe may be mortared in directly without using a wall thimble, if the wall is non-combustible. Install wall thimble into wall, observing the aforementioned rules and/or local building codes. Select the point of wall penetration where the minimum 1/4" per foot of slope (6.4 mm per 305 mm) can be maintained. A framed opening is required to insert the thimble halves. The thimble is adjustable for different wall thicknesses. Caulk around outside edge of plates as necessary and fasten to wall using suitable screws or nails. The vent pipe must be sealed at wall thimble as per code regarding continuous vapor barrier.
2. The system can now be assembled through the thimble (attach the termination first - note "UP" arrow) and then back to the appliance as per illustration using JOINT PROCEDURE as described on page #3. A gear clamp (or locking band) must be installed around the pipe on the inside of wall to trap pipe in position so that the system cannot be moved in or out of wall. This applies to both combustible and non-combustible walls
3. The system must be supported along its horizontal length at all elbow locations and joints (every forty-eight inches or less) using straps around pipes maintaining clearance to combustibles as per table on page 3.
4. The horizontal distance of the system from the appliance flue collar to the outside of the Horizontal termination cannot be greater than that specified in the manufacturer's installation instructions and not be less than four (4) feet unless the vent is through a non-combustible wall.

Any horizontally installed portion of a venting system shall have a slope (upwards for Category II, III, or IV appliances or downwards for Category III or IV appliances) not less than 1/4" (6.4 mm) every 12 inches (305 mm) to prevent collection of condensate at any location in the assembly. Fasteners must not penetrate the components of the system either when joining pipes and fittings or using support straps. The lengths of pipe may be cut on non-expanded end using aviation snips or a hacksaw (24 tpi). The cut end must be filed or sanded smooth before joining. When installing the condensate tube be sure to form a trap by means of a 3" (76.2 mm) loop filled with water. This tube must be 3/8" ID high temperature silicone for at least the first 6 inches (152 mm) and attached with a gear clamp or hose clamp. The effluent must be disposed of according to local regulations.

NOTE: Z-FLEX recommends using a neutralizer kit when using a condensate trap. A condensate pump may be required.

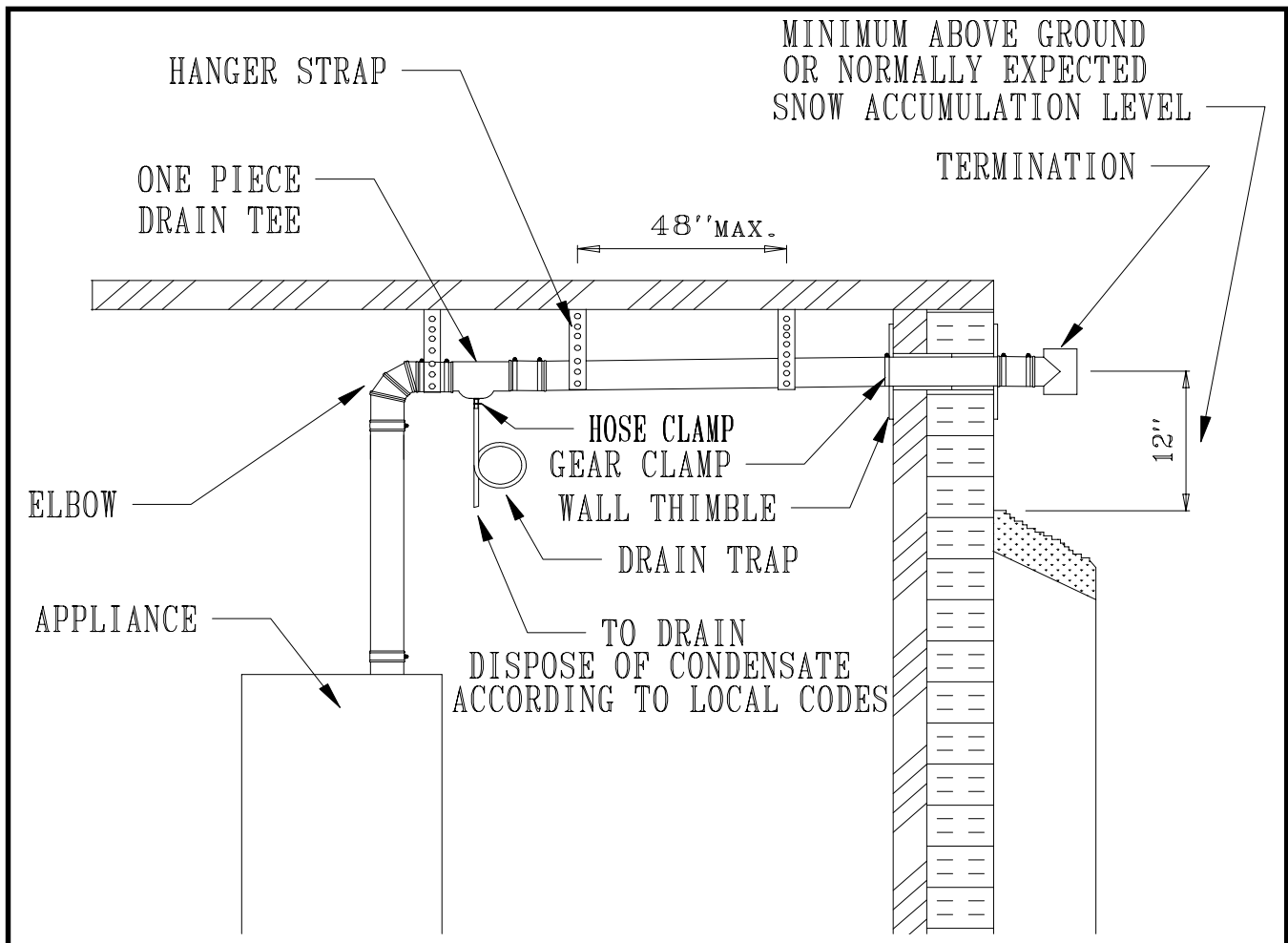

VERTICAL VENTING

(see illustrations #3 & 4)

NOTE: The vent termination above the roof line shall consist of a continuous section of vent pipe only (without any joints) and must be at least 3 ft. (1 m) to a maximum of 6ft. above the roof line and 2 ft. (.61 m) higher than any part of a structure within 10 ft. (3.1 m). The total vertical distance of the vent system from appliance flue collar to the rain cap termination and the maximum length of offsets shall not exceed that specified in the appliance manufacturer's installation instructions. No continuous vertical run shall be longer than sixty feet (18.3 m). All horizontal sections must observe the rules for **HORIZONTAL VENTING**. The clearance to combustibles inside a chase shall be no less than 4" (100 mm).

1. Prior to beginning the installation loosely assemble all parts required to make sure all parts are present.
2. Locate position for venting system and proceed to cut holes for firestop support and firestop spacers. All vertical installations require the use of a support. Frame the opening of the floor using lumber, which is dimensionally consistent with the structural members. Insert the support from beneath the framed opening and secure with nails or screws as required.
3. Refer to **JOINT PROCEDURE** (illustration #1) before assembling system.
4. Install system joining pipe as required up through roof (illustration page 7). Tighten gear clamp on firestop support to hold vent system. **NOTE:** A firestop must be provided when a vent passes through a combustible floor or ceiling. The opening must be framed for the support since the support also serves as a firestop.
5. The roof flashing can now be installed. Where the vent passes through the roof a flashing must be used to maintain the required clearances and to protect from the elements. The framed opening must be large enough to provide the necessary clearances to combustibles, taking into account the slope of the roof. The flashing can be used on slopes from flat to 6/12 pitch. Install the flashing while holding the pipe centered in the opening. Fasten the flashing to the roof under the roofing material upslope from the pipe and above the roofing material below the pipe. Seal as required using high temperature silicone.
6. Install Top Support around pipe and against flashing collar. (illustrations #3,4,5,6)
7. Attach rain cap using **JOINT PROCEDURE** (illustration #1)
8. The vertical section is connected by an elbow joined to the horizontal run and then through a drain tee (see page 4 for details) to the appliance. Elbows are joined to pipe using the **JOINT PROCEDURE** (illustration #1).

NOTE: If there is no solid anchor point in the system below the roof (ie Firestop Support etc.) then a Z-Vent Guy Band must be used below the roof as follows. (see illustration #6)

- a. Attach the Guy Band at any point above an elbow or tee in the vertical section within 20 feet of the roof.
- b. Fasten stainless steel or galvanized cable with a minimum capacity of 500 lbs. to each of the four anchor holes.
- c. Anchor the cables to a rigid building member using an appropriate fastening method.

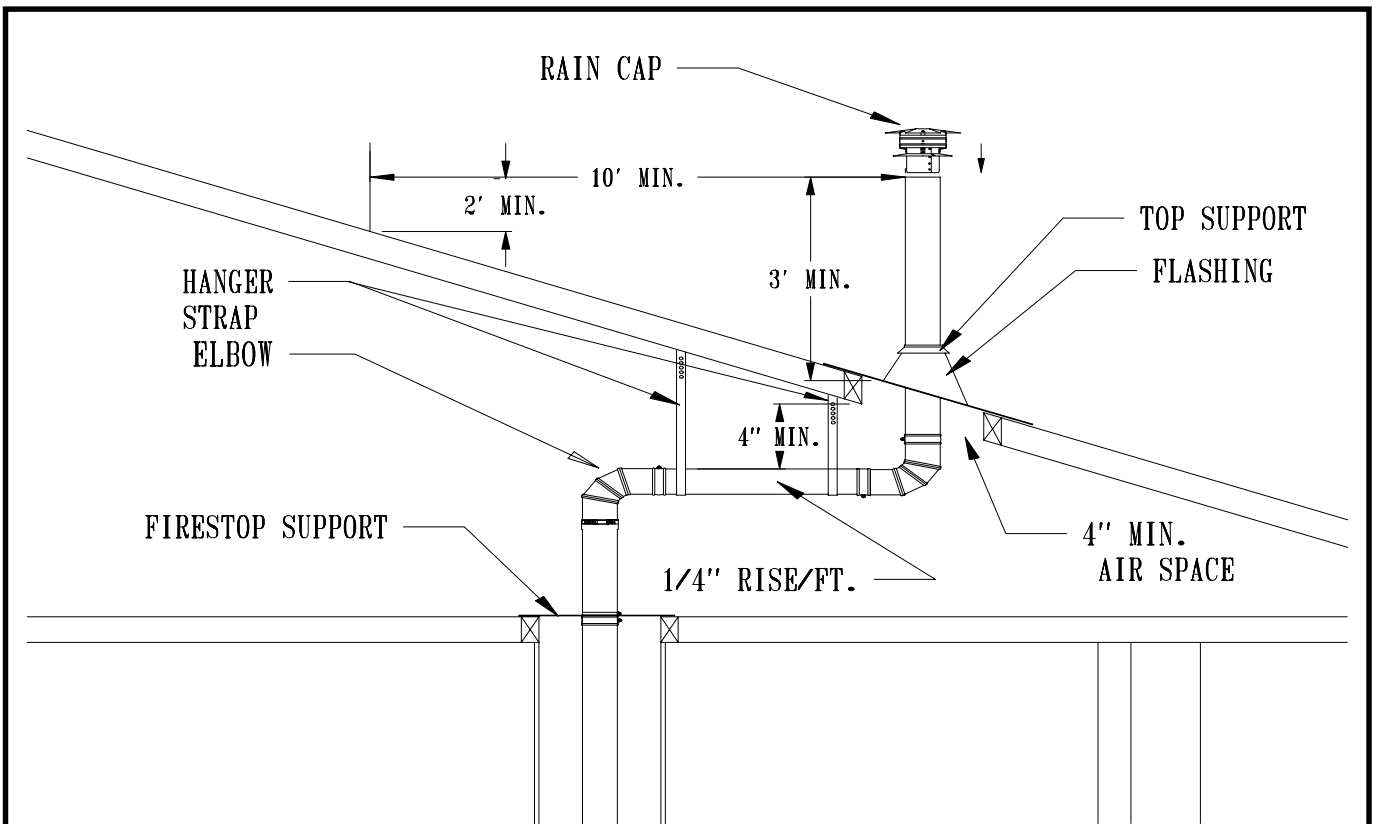

ILLUSTRATION #3

ABOVE THE ROOF

(see illustration #6)

NOTE: When Z-Vent must be extended above the roof line more than six (6) feet the Guy Band must be used to support the system.

1. Install the Guy Band below the Rain Cap using the 10-24 screw and nut provided.
2. Attach stainless steel or galvanized cable with a minimum rated capacity of 500lbs. to each of the four anchor holes.
3. Anchor the cables to a rigid building member using an appropriate fastening method

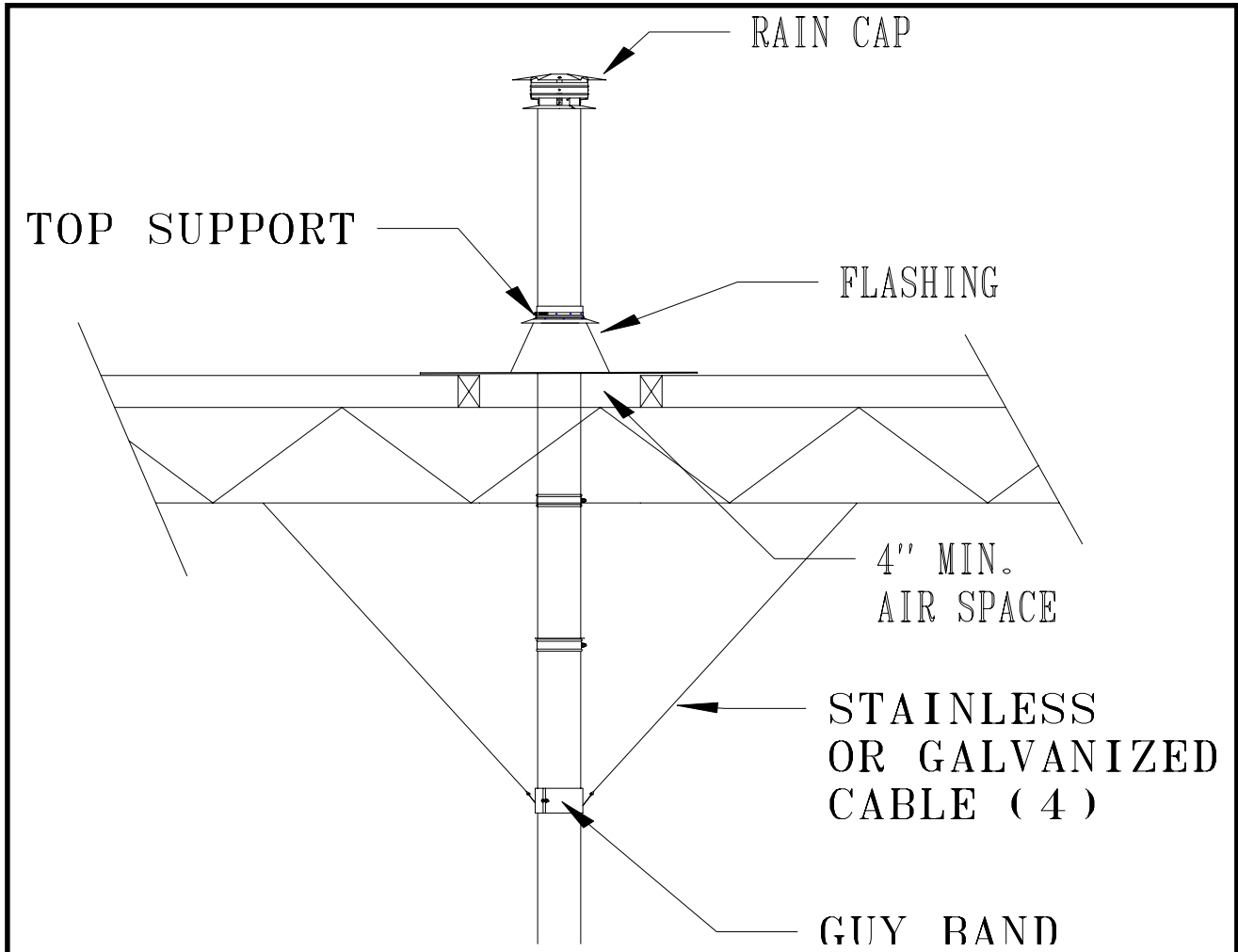

EXISTING MASONRY CHIMNEY

(see illustration #5)

NOTE: A masonry chimney flue may be used to route Z-VENT if no other appliance vents directly into the same flue without a liner. Prior to beginning the installation, be sure that the existing chimney meets all national and local building codes. The chimney must be cleaned, removing all soot, debris and creosote before installing Z-VENT.

1. Using the JOINT PROCEDURE, (illustration #1) join pipe lengths as they are lowered down the chimney until bottom end lines up with opening in chimney. (A rope may be used to facilitate lowering of pipe).
2. Install flashing over last pipe length and attach top support to pipe. Leave 6" (150 mm) of pipe protruding from flashing so that rain cap may be installed and to allow for any adjustment to line up base tee properly.
3. Fasten flashing to chimney top using caulking and/or screws. If the top clay tile is still in place, the corners of the flashing must be notched and flashing plate formed down around clay tile.
4. The rain cap may now be installed using the JOINT PROCEDURE (illustration #1).
5. Where required a drain tee should be installed to a pipe as per JOINT PROCEDURE (illustration #1).
6. The remainder of the horizontal installation to the appliance can be done the same as for side wall venting on page 4 observing rules for HORIZONTAL VENTING.
7. Final adjustment may be made to the top support if necessary.

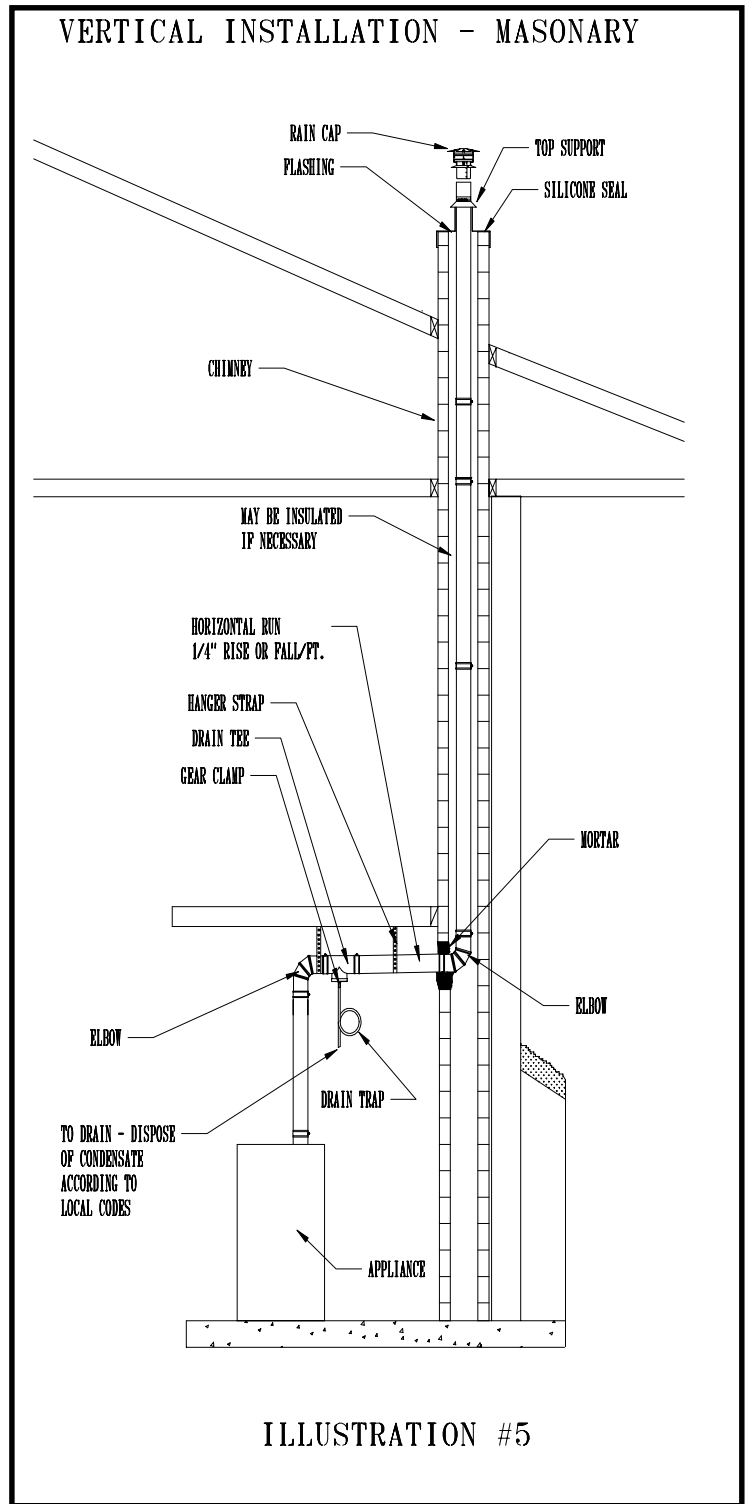
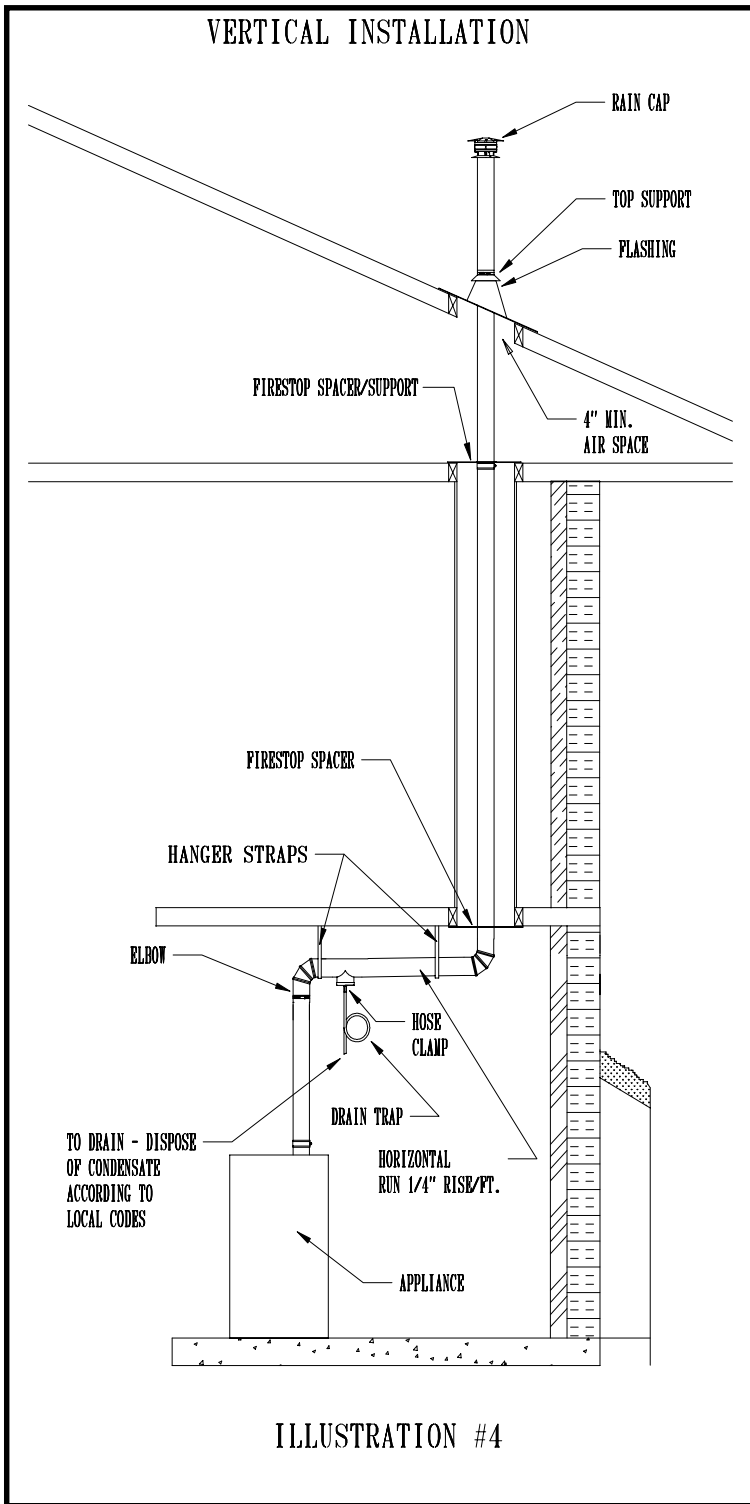

APPLIANCE CONNECTION

Refer to the appliance manufacturer's installation manual for proper method of joining Z-VENT to the appliance collar. An appliance adapter to suit specific requirements may be obtained from Z-FLEX.

IMPORTANT NOTICE

When any of the previous installation procedures are completed, be sure to go over the entire system to make sure all joints are secure and sealed correctly. The seams and joints must be checked for tightness prior to using the venting system.

A qualified inspector must check the entire system at least once annually following initial installation to maintain the Z-FLEX warranty.

The installation must conform to the requirements of the appliance manufacturers' instructions, The National Fuel Gas Code and local codes and regulations.

Z-FLEX® LIMITED LIFETIME WARRANTY

Z-FLEX® ("Seller") extends the following LIMITED WARRANTY for Z-VENT (the "Z-Vent"):

Seller warrants that at the time of purchase, the Z-Vent will be free of manufacturer's defects in material and/or workmanship. This warranty shall extend to the original purchaser of the Z-Vent or, if purchased by a contractor, to the end user. This warranty is valid for a period of fifteen (15) years from the date of purchase, provided that the Z-Vent has been installed according to Z-Flex® installation instructions. Deviating from the installation and use instructions included with the Z-Vent will void the warranty.

Under this Limited Warranty, Seller's sole responsibility and liability shall be to replace the Z-Vent and/or accessories, if found by Seller to be defective according to the terms of the warranty, and shall not include replacement installation or other costs.

IMPORTANT: The Z-Vent is designed for use with Category II, III and IV furnace and boiler venting and should not be used with any other type of furnace and boiler venting. Use of the Z-Vent with any other type of furnace and boiler venting other than those recommended by Seller for use with its Z-Vent will void the warranty.

WARNING: CONDENSATION WITH HIGH ACID CONTENT MAY BE PRODUCED DUE TO UNFORESEEN CONDITIONS. YOUR HEATING APPLIANCE AND VENTING SYSTEM SHOULD BE INSPECTED BY A LICENSED CONTRACTOR ON AN ANNUAL BASIS FOR POSSIBLE SIGNS OF DETERIORATION DUE TO RUSTING OR PIN HOLES. CONDENSATION WITH HIGH ACID CONTENT MAY CAUSE LEAKAGE OF HARMFUL GASES WHICH CAN CAUSE NAUSEA, FAINTING OR DEATH. IF DETERIORATION IS DETECTED CEASE USE OF HEATING SYSTEM AND CALL FURNACE/BOILER INSTALLER FOR REMEDIAL ACTION.

To activate the warranty, the end-user must complete and return the Z-Flex® Warranty Registration Card within ninety (90) days of installation of the Z-Vent. Upon written notice of any defects, Z-Flex® reserves the right to examine or establish reasonable proof of defective material or workmanship justifying replacement.

NO OTHER EXPRESS WARRANTY HAS BEEN MADE OR WILL BE MADE ON BEHALF OF SELLER WITH RESPECT TO THE Z-VENT OR THE INSTALLATION OR REPLACEMENT OF THE Z-VENT. SELLER SHALL NOT BE LIABLE FOR ANY SPECIAL, INCIDENTAL, INDIRECT OR CON-SEQUENTIAL DAMAGES.

As some jurisdictions do not allow the exclusion or limitation of incidental or consequential damages, the above limitations or exclusions may not apply to you.

IMPLIED WARRANTIES, INCLUDING ANY WARRANTY OF MERCHANTABILITY OR FITNESS FOR A PARTICULAR PURPOSE, IMPOSED ON THIS SALE UNDER STATE LAW, ARE LIMITED TO THE PERIOD DURING WHICH THIS WARRANTY IS IN EFFECT. AS SOME JURISDICTIONS DO NOT ALLOW LIMITATIONS ON THE LENGTH OF AN IMPLIED WARRANTY, THE ABOVE LIMITATION MAY NOT APPLY TO YOU.

Claims under this Warranty must be made within the warranty period in writing and directed to: In the USA; Warranty Claims, Z-Flex®(US) Inc., 20 Commerce Park North, Bedford, New Hampshire 03110, (603) 669-5136 or (800) 645-5600. In Canada; Warranty Claims, Z-Flex® Inc., 452 Attwell Drive, Etobicoke, Ontario, M9W 5C3, (416) 679-0045.

This Warranty gives you specific legal rights, and you may also have other rights that vary in different States and Provinces.



WARRANTY REGISTRATION CARD: Z-FLEX®

For this warranty to be effective, this card must be completed upon purchase of the covered Z-Vent and returned to Z-Flex® within ninety (90) days of installation of the Z-Vent.

Original end-user's name: _____

Address of premises in which the Z-Vent is installed: _____

Z-Vent purchased from: _____

Date of Installation: _____

Type of Heating System into which Z-Vent installed: _____

I understand and agree to the Warranty as stated: _____

Signature

Date

Flexmaster Canada Limited
Model SVEIII Instructions Ver. 4.0 Jan. 23, 2003