



# Woodburning Range



## SAFETY NOTICE

**PLEASE READ THIS ENTIRE MANUAL BEFORE YOU INSTALL AND USE YOUR NEW COOK STOVE. FAILURE TO FOLLOW INSTRUCTIONS MAY RESULT IN PROPERTY DAMAGE, BODILY INJURY OR EVEN DEATH. SAVE THESE INSTRUCTIONS FOR FUTURE REFERENCE.**

**IF THIS APPLIANCE IS NOT PROPERLY INSTALLED, A HOUSE FIRE MAY RESULT. FOR YOUR SAFETY, FOLLOW THE INSTALLATION DIRECTIONS. CONTACT LOCAL BUILDING OR FIRE OFFICIALS ABOUT RESTRICTIONS AND INSTALLATION INSPECTION REQUIREMENTS IN YOUR AREA.**

**THIS APPLIANCE MUST BE CONNECTED TO A LISTED, HIGH-TEMPERATURE RESIDENTIAL TYPE AND BUILDING HEATING APPLIANCE CHIMNEY OR AN APPROVED MASONRY CHIMNEY WITH FLUE LINER.**

**THE COMPLETE INSTALLATION MUST BE DONE IN ACCORDANCE WITH CURRENT STANDARDS AND LOCAL CODES. IT SHOULD BE NOTED THAT THE REQUIREMENTS AND THESE PUBLICATIONS MAY BE SUPERSEDED DURING THE LIFE OF THIS MANUAL.**

**THIS APPLIANCE IS HOT WHILE IN OPERATION AND RETAINS ITS HEAT FOR A LONG PERIOD OF TIME AFTER USE. CHILDREN, AGED OR INFIRM PERSONS SHOULD BE SUPERVISED AT ALL TIMES AND SHOULD NOT BE ALLOWED TO TOUCH THE HOT WORKING SURFACES WHILE IN USE OR UNTIL THE APPLIANCE HAS THOROUGHLY COOLED.**

**MANUFACTURED BY: WATERFORD STANLEY (MARKETING) LTD., BILBERRY, WATERFORD, IRELAND.**

**ASSEMBLY INSTALLATION AND OPERATING INSTRUCTIONS**

---

# TABLE OF CONTENTS

	<b>PAGE</b>
Assembly . . . . .	2
Installation . . . . .	4
Installation Clearances to Combustibles . . . . .	4
Reduced Clearances . . . . .	4
Rear Exit . . . . .	4
Floor Protection . . . . .	5
Chimney . . . . .	5
Chimney Types USA . . . . .	5
Chimney Type Canada . . . . .	5
Chimney Connector . . . . .	5
Chimney Connector USA Only . . . . .	5
Connecting to Masonry Chimney . . . . .	6
Thimbles . . . . .	6
Chimney Connector Systems, Thimbles & Clearances From Combustible Walls . . . . .	6
Masonry Fireplace . . . . .	7
Ventilation & Combustion Air Requirements . . . . .	8
Spillage Test . . . . .	8
Maintenance . . . . .	9
Efficient Economical Use Of Wood . . . . .	9
Creosote - Formation & Need For Removal . . . . .	9
Disposal Of Ashes . . . . .	10
Hints On Fire Safety . . . . .	10
Fuels . . . . .	10
Lighting The Fire . . . . .	10
Controlling The Fire . . . . .	10
The Hotplate . . . . .	11
The Oven . . . . .	11
Overnight Burning . . . . .	11
Riddling . . . . .	11
Flue Cleaning . . . . .	11
Chimney Cleaning . . . . .	11
Use Of Tools . . . . .	11
Vitreous Enamel Cleaning . . . . .	11
Warming Shelf - Left or Right Hand Location . . . . .	12
Assembly Instructions - Warming Oven . . . . .	13
Exploded View . . . . .	14
Warranty . . . . .	15

## ASSEMBLY

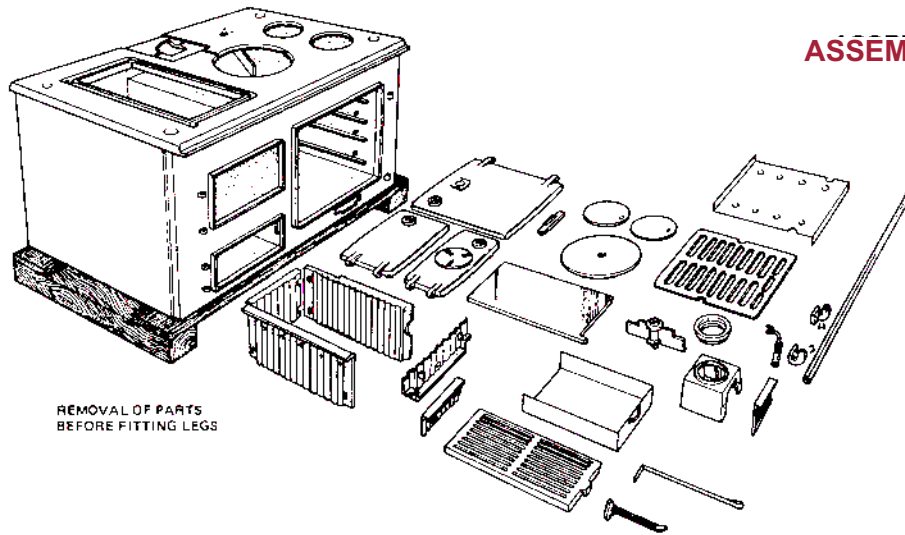

Fig.1

1. Remove packing strip from the top of the range. Place the sheet steel back plate to one side. Remove all loose components from the top of the range and firebox and the oven. Remove the oven door. Spread the components on the floor so you can identify them easily.
6. Fit the complete skirting under the front of the range inside the front legs using a screw and nut to secure it to each leg.
7. Move the range into position for installation. CAREFUL: Do not break a leg!

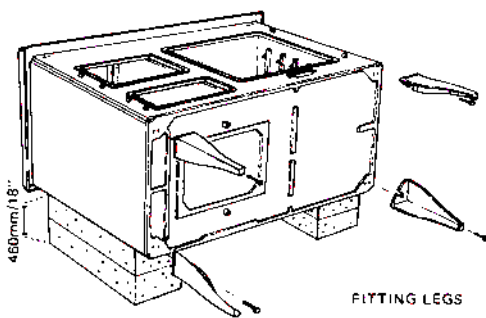

Fig.2

2. Place cement blocks or other strong supports about 458mm (13") high behind the range. Space the supports behind it and lay the cooker on its back.
3. Fit the four legs (Part no. 36) to the four base corners (Part no. 13) using the hexagon-head bolts and washers. Note that each of the front legs (No. 36) has a screw hole in the front.
4. Lift the range off the supports. Stand it upright without putting any strain on the legs.
5. Join the two sections of the front skirting together (Part Nos. 37 and 38) by screwing the name plate (Part No. 51) with its back fixing strip (Part No. 54) into position between the two sections and secure the two sections tightly to the name plate.

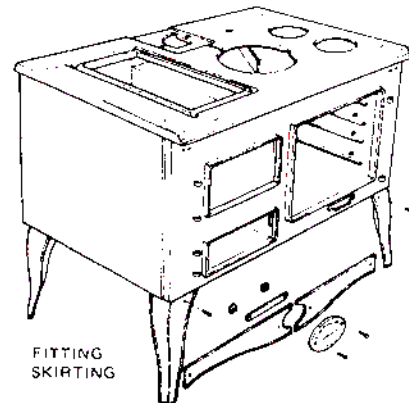

Fig.3

8. Ensure that the cast iron fire liners (part nos.44,46,47,48 & 49) are secure in the firebox at the front, sides and back.
9. Place the oven damper in position (Part No. 63) on top of the oven and place the round hotplate (Part No. 20) in position above it. Place the oblong hotplate (Part No. 19) and the two round cleaning cups (Part No. 15) in position to complete the cooker top.
10. Place the top flue outlet (Part No. 55) in position and fit its front cleaning door (Part no. 56) in position.
11. Screw the towel rail brackets (Part Nos. 25 and 26) to the top front of the range (Part No. 1) and fix the towel-rail (Part No.78) in position between the brackets. Tighten up the screws.

12. Hang the fire door (Part No. 57) and the ashpit door (Part No. 3) on their hinges.
13. Place the oven shelves in position (Part No.12) the cast iron shelf below the sheet steel shelf.
14. Place the cleaning door (Part No. 59) in position beneath the oven door (Part No. 2).
15. Screw the splashback (Part No. 67) to its two supports (Part Nos. 61 & 62) keeping the folded end to the bottom. Screw the plate rack (Part No. 88) to the splashback. Screw the complete assembly on to the cooker top (Part No. 18).

The Waterford Stanley Woodburning Range is equipped for top flue connection. Should you wish to vent the range to the rear the following modifications must be undertaken:

1. Remove the top flue collar (item 1) and seal the opening with the blanking plate (item 2) provided.
2. Remove the small panel (item 3) from the back of the range and the blanking plate (item 4) which will now be visible.
3. Screw the rear flue collar (item 5) provided to the back of the range.

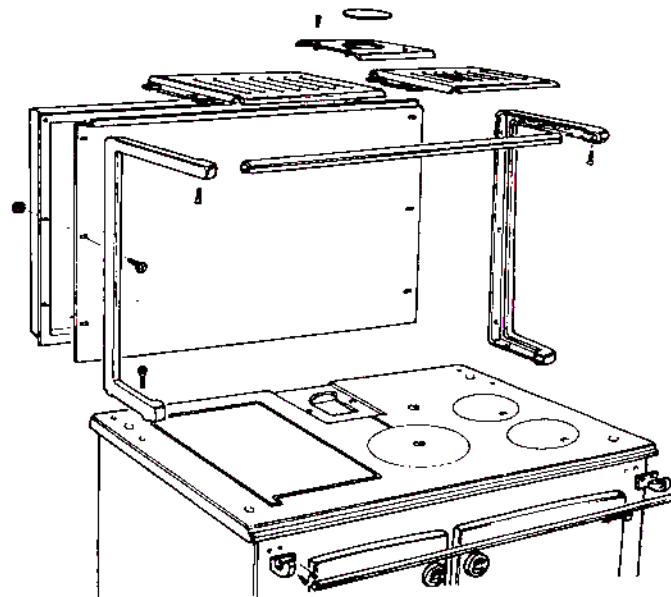

Fig.5

**Note:** Platerack and Splashback is an optional extra, not supplied as standard.

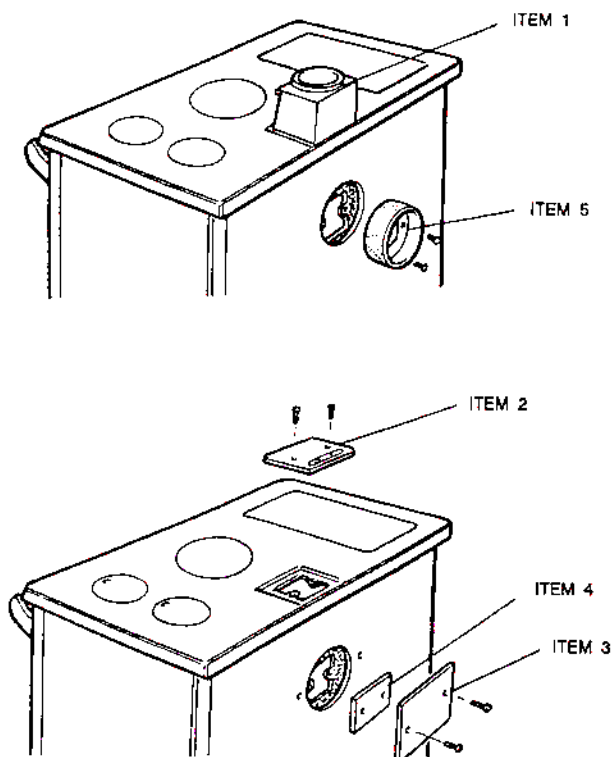

Fig.4

# INSTALLATION

When installing, operating and maintaining a solid fuel heater, respect basic standards of fire safety. Read these instructions carefully before commencing the installation. Failure to do so may result in damage to persons and property. Consult your local municipal office, Fire Department and your insurance representative to determine what regulations are in force.

## INSTALLATION CLEARANCES TO COMBUSTIBLES

Front	48"	1220mm
Back	16"	400mm
Oven Side	6"	150mm
Oven Side with Optional Shelf Fitted	10"	250mm
Firebox Side	12"	300mm
Single Wall Flue Pipe	18"	460mm

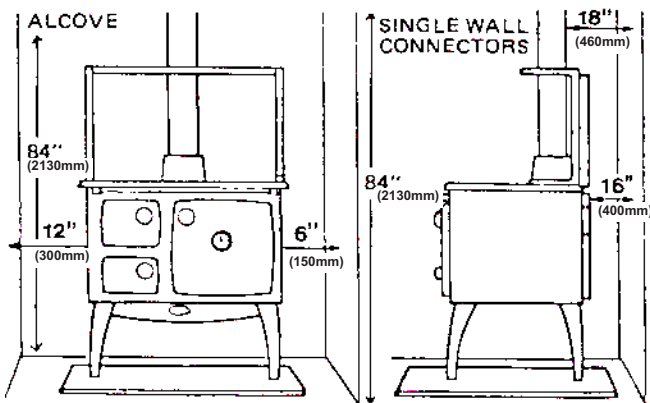
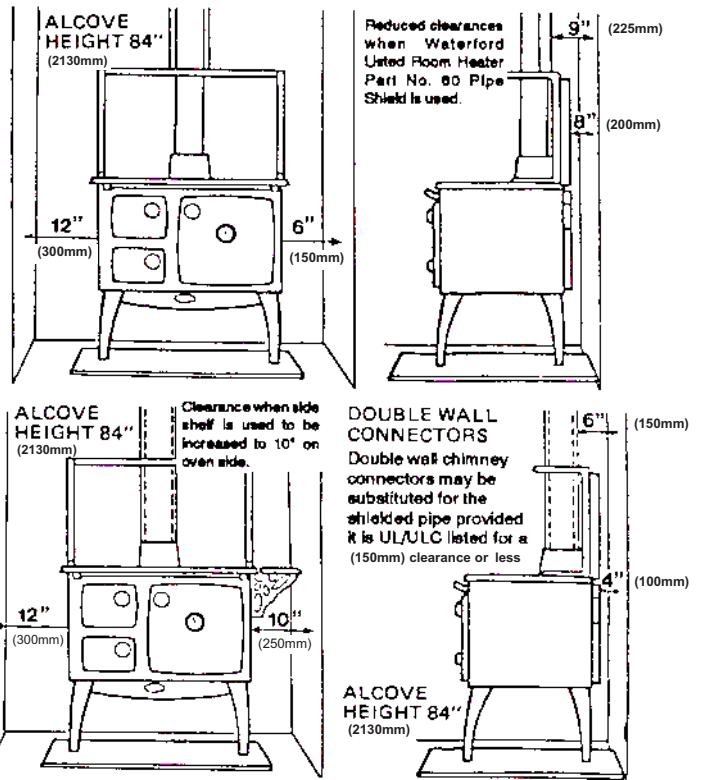
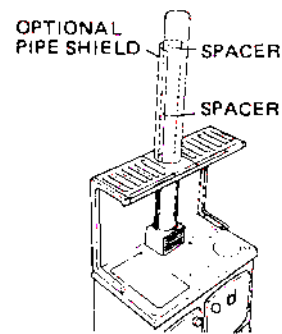

Fig. 6

## REDUCED CLEARANCES

These clearances may be reduced by the application of protection to combustible walls and ceilings. ULC/UL Labelled Heat Shields installed in accordance with the manufacturers instructions or shields complying with the requirements of "Installation Code for Solid Fuel Fired Appliances CAN31336" or "Standard for Chimneys, Fireplaces and Vents NFPA No. 211."

Fig. 7



## REAR EXIT

Back	6"	150mm
Oven side	6"	150mm
Firebox Side	12"	300mm

Fig. 8

## REAR EXIT

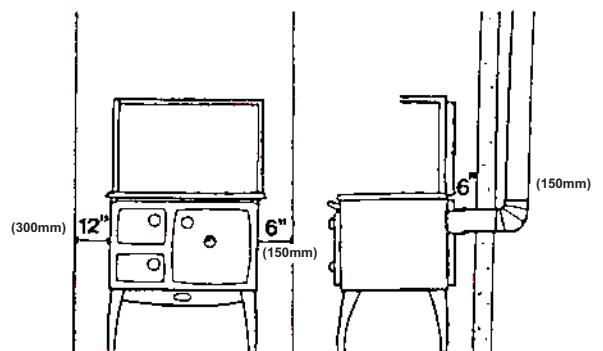

## FLOOR PROTECTION

When installing the Waterford Stanley Woodburning Range on a combustible floor, a floor protector consisting of a layer of non-combustible material at least 3/8" (9mm) thick of 1/4" (6mm) thick covered with a 1/8" (3mm) sheet of metal is required to cover the area under the heater and to extend to at least 18" (460mm) at the front and 8" (200mm) to the sides and back of stove. This will provide protection from sparks and embers which may fall out from the door when stoking or refuelling.

Floor Protection and Location

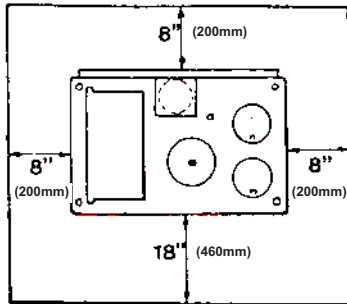

Fig.9

To be used for all installations

## CHIMNEY

The Waterford Stanley Woodburning Range must be connected to a Factory-Built Chimney, installed in accordance with the manufacturer's instructions or a lined masonry chimney, acceptable to the authority having jurisdiction. An existing masonry chimney should be inspected and if necessary repaired by a competent mason or be relined using an approved relining system.

**THE CHIMNEY SERVING THE WATERFORD STANLEY WOODBURNING RANGE SHOULD NOT SERVE ANY OTHER APPLIANCES.** If you intend to use a fireplace chimney, the fireplace opening must be sealed. The overall height of the chimney, measured from the floor on which the Range is installed must be at least 4.572 meters (15ft). Do not use more than two elbows.

## CHIMNEY TYPES USA

The Residential Type Chimney may be:

- FACTORY-BUILT U.L. Listed Residential Type HT and Building Heating Appliance chimney (ANSI/UL103) and acceptable to the local building core or,
- MASONRY, Constructed in accordance with NFPA 211 code.

## CHIMNEY TYPE CANADA

This Waterford Stanley Woodburning Range must be connected to an Underwriters Laboratories of Canada Labelled factory Built 650°C Chimney, installed in accordance with the manufacturer's instructions or a lined masonry chimney acceptable to the authority having jurisdiction.

## CHIMNEY CONNECTOR

Single wall stove pipe, used to connect the appliance to the chimney must be installed with the crimped end towards the stove. This will ensure that condensing moisture from the burning wood will flow back into the fire chamber. Each joint in the stove pipe must be secured with a least 3 sheet metal screws.

Connectors should be 6" 153mm in diameter and crimped into the fire outlet collar. Corrosion-resistant steel, 24 gauge or heavier, is recommended. (Cheap metal pipes are easily damaged by flue gas acids).

A minimum clearance of 450mm (18") is required for a single wall connector.

## CHIMNEY CONNECTOR USA ONLY

Connectors should maintain a pitch or rise of at least 1/4" (6mm) to the foot from this cook stove to the chimney. It should be installed so as to avoid sharp turns or other construction features that would create excessive resistance to the flow of flue gasses. It should be securely supported with joints fastened with sheet-metal screws, rivets or other approved means. The entire length of a connector should be readily accessible for inspection, cleaning and replacement.

The connector may pass through walls or partitions constructed of combustible materials provided the connector is either listed for wall pass-through or is routed through a device listed for a wall pass-through and is installed in accordance with the conditions of the listing. Any unexposed metal that is used as part of a wall pass-through system is exposed to flue gasses shall be constructed of stainless or other equivalent material that will resist corrosion, softening, or cracking from flue gas at temperatures up to 982° C.

Where passage through a wall, or partition of combustible construction is desired, the installation shall conform to CAN/CSA - B 365, Installation Code for Solid Fuel Burning Appliance & Equipment.

## CONNECTING TO MASONRY CHIMNEY

The connector to a masonry chimney must extend through the wall to the inner face or liner but not beyond, and must be firmly cemented to masonry.

The connector may pass through walls or partitions constructed of combustible material to a masonry chimney provided the connector system selected is installed in accordance with the proper clearances and conditions.

## THIMBLES

Thimbles for chimneys or vent connectors should be of fire clay (ASTM C 315, specifications for Clay Flue Linings), galvanized steel of minimum thickness of 24 gauge, or material of equivalent durability. Thimbles should be installed without damage to the liner. The thimble should extend through the wall to, but not beyond, the inner face of the liner and should be firmly cemented to masonry.

Thimbles should be located to provide adequate pitch or rise of chimney or vent connectors and, where the ceiling above the appliance is constructed of combustible material, the location of the thimble should provide minimum clearance required for the connector as specified in section under Minimum Clearances to Combustibles.

Insulation material used as part of wall pass-through system should be of non-combustible material and should have a thermal conductivity of 1.0 Btu. in./ft.F (4.88kg.cal/hr.m.c) or less. All clearances and thicknesses are minimums; larger clearances and thicknesses are acceptable. Any material used to close up the opening for the connector should be of non-combustible material. A connector to a masonry chimney, except for System 2 (under heading Chimney Connector System, Thimbles and Clearances), shall extend to piece through the wall pass-through system and the chimney wall to the inner face of the flue liner, but not beyond.

## CHIMNEY CONNECTOR SYSTEMS, THIMBLES AND CLEARANCES FROM COMBUSTIBLE WALLS

1. Minimum 3 1/2" (90mm) thick brick masonry wall framed into combustible wall with a min. of 12" (305mm) brick separation from clay liner to combustibles. Fire clay liner (ASTM C315 or equivalent) min. 5/8" (16mm) wall thickness, should run from outer surface of brick wall to, but not beyond, the inner surface of chimney flue liner and should be firmly cemented in place.

Fig.10

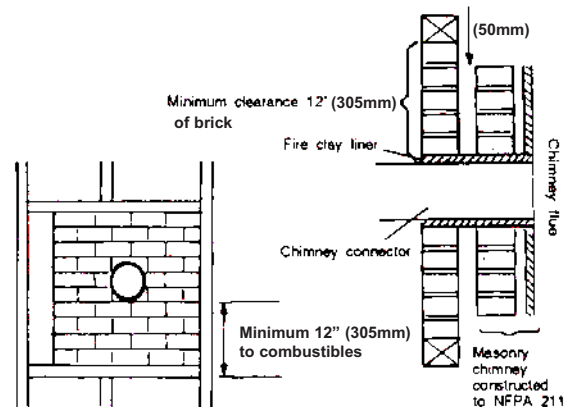

2. Solid insulated listed factory-built chimney length of the same inside diameter as the chimney connector and having 1" (25mm) or more of insulation with a min. 9" (230mm) air space between the outer wall of the chimney length and combustibles. The inner end of the chimney length shall be flush with the inside of the masonry chimney flue and shall be sealed to the flue and to the brick masonry penetration with non water-soluble refractory cement. Supports should be securely fastened to wall surfaces on all sides. Fasteners between supports and the chimney length shall not penetrate the chimney liner.

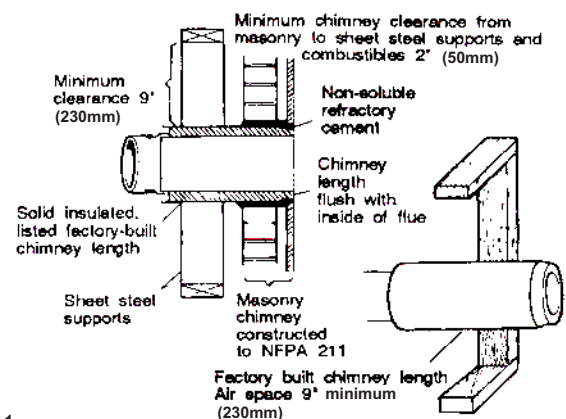

Fig.11

- Sheet steel chimney connector, min. 24 gauge in thickness, with a ventilated thimble, min. 24 gauge in thickness, having two 1" (25mm) air channels, separated from combustibles by a min. of 6" (150mm) of glass fibre insulation. Opening should be covered and thimble supported with a sheet steel support, min. 24 gauge in thickness. Supports should be securely fastened to wall surfaces on all sides and should be sized to fit and hold chimney section. Fasteners used to secure chimney sections should not penetrate chimney flue liner.

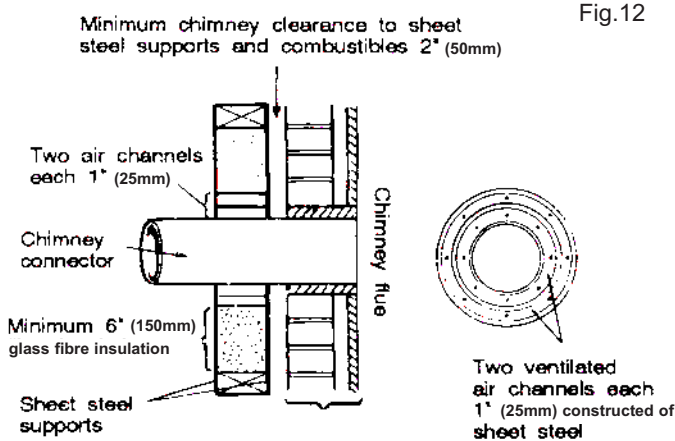
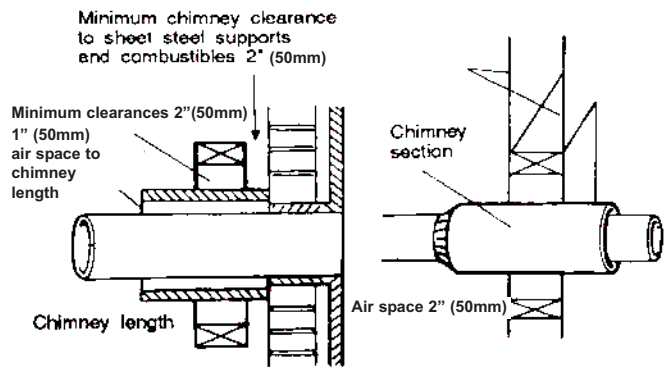

Fig.12

- Solid insulated listed factory-built chimney length with an inside diameter 2" (50mm) larger than the chimney connector and having 1" (25mm) or more of insulation, serving as a pass-through for a single wall sheet steel chimney connector of min. 24 gauge thickness, with a min. 2" (50mm) air space between the outer wall of chimney section and combustibles. Min. length of chimney section shall be 12" (305mm). Chimney section concentric with and spaced 1" (25mm) away from connector by means of sheet steel support plates on both ends of chimney section. Opening shall be covered and chimney section supported on both sides with sheet steel supports of min. 24 gauge thickness.

Supports should be securely fastened to wall surfaces on all sides and shall be sized to fit and hold chimney section. Fasteners used to secure chimney sections should not penetrate chimney flue liner.

Fig.13



## MASONRY FIREPLACE

Before the installation the entire fireplace system should be inspected for condition and code compliance prior to connecting to the fireplace chimney. Older fireplaces and chimneys may not have been constructed to current-day codes.

The fireplace and chimney should be in, or brought up to, acceptable conditions and proper clearances should be met before connecting to the fireplace chimney.

The size of the flue must be considered. If the fireplace chimney is too large, a relining system may be installed using an approved relining system.

Fig.14

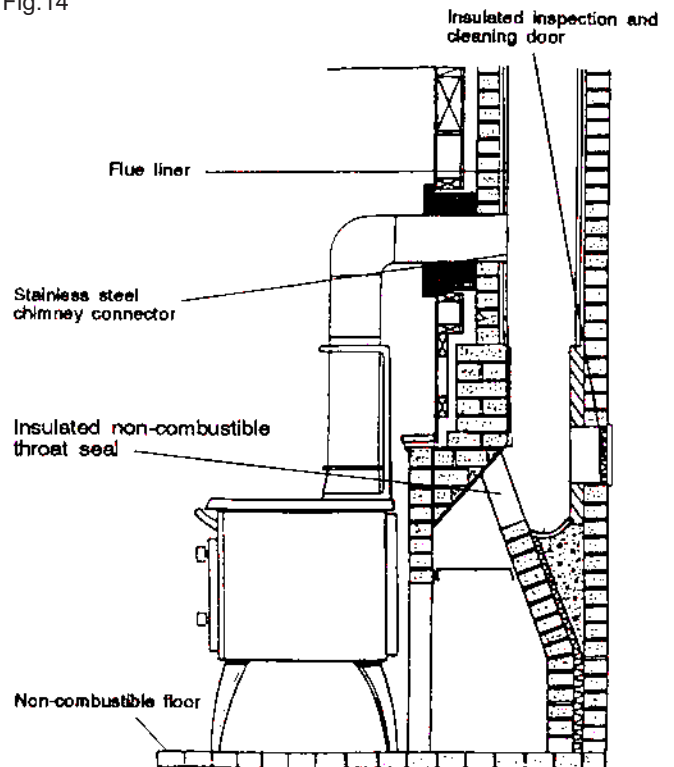
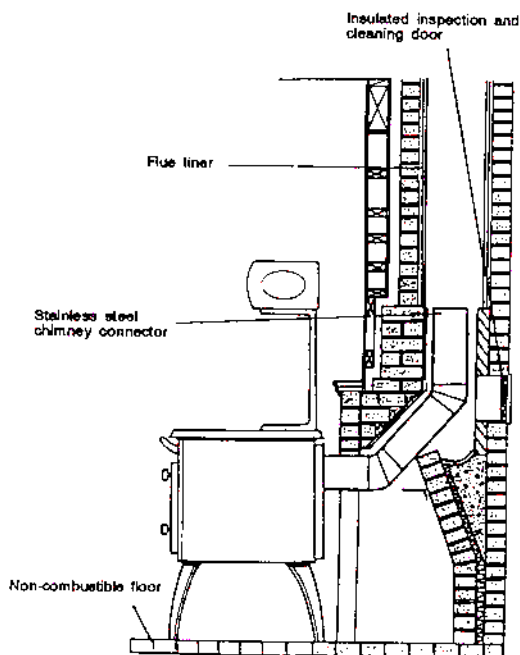



Fig.15



Connection to a masonry chimney may be done by breaching into the chimney from the front of the fireplace, no less than 8" (200mm) above the bottom of the first flue tile, by installing a stainless steel or other listed chimney connector from the appliances flue outlet up through the fireplace damper and smoke chamber, terminating at the first flue tile, or by installing a stainless steel or other listed relining system from the flue outlet up the entire length of the chimney, where necessary.

## VENTILATION & COMBUSTION AIR REQUIREMENTS

Provision for outside combustion air may be necessary to ensure that fuel-burning appliances do not discharge products of combustion into the house. Guidelines to determine the need for additional combustion air may not be adequate for every situation. If in doubt, it is advisable to provide additional air.

Outside combustion air may be required if:

1. The solid-fuel-fired appliance does not draw steadily, smoke rollout occurs, fuels burns poorly, or back drafts occur whether or not there is combustion present.
2. Existing fuel-fired equipment in the house, such as fireplaces or other heating appliances, smell, do not operate properly, suffer smoke roll-out when opened, or back-draft whether or not there is combustion present.
3. Opening a window slightly on a calm (windless) day alleviates any of the above symptoms.

4. The house is equipped with a well-sealed vapour barrier and tight fitting windows and/or has any powered devices that exhaust house air.
5. There is excessive condensation on windows in the winter.
6. A ventilation system is installed in the house.

If these or other indications suggest that infiltration air is inadequate, additional combustion air should be provided from the outdoors. Outside combustion air can be provided to the appliance by the following means:

1. Indirect method: for an appliance not certified for direct connection of outside combustion air, the outside air is ducted to a point no closer than (12") 300mm from the appliance, to void affecting the performance of the appliance.
2. A mechanical ventilation system: if the house has a ventilation system (air change or heat recovery):
  - a. The ventilation system may be able to provide sufficient combustion make-up air for the solid-fuel-fired appliance.
  - b. The householder should be informed that the ventilation system might need to be re-balanced by a ventilation technician after installation of the appliance.

## SPILLAGE TEST

In all installations a spillage test should be carried out to ensure there is sufficient combustion air and the flue system is:

1. Light/burn appliance under normal conditions in accordance with this installation manual.
2. Close all doors and windows.
3. Operate all appliances requiring air at full rate (eg. extraction hoods, tumble dryers etc).
4. Check for spillage.

---

## MAINTENANCE

### **WARNING: DO NOT CLEAN STOVE WHEN HOT.**

To ensure that the Waterford Stanley Woodburning Range will operate safely and with maximum efficiency, the entire installation must be properly maintained. During periods of use, the range, chimney connectors, joints and the main flue itself must be kept clean and in good working condition. You can clean the connectors manually. Use an approved chimney cleaner to clear creosote deposit and repeat as often as necessary. If you use only seasoned hardwoods, then only occasional chimney cleaning will be necessary.

During the off-season the range may be stored in a dry, covered area, but before storing it, remove the ashes and thoroughly clean out the fire chamber and oven flues. Touch up the black Senotherm finish as required with similar heat-resistant finish. If such are not readily available apply a suitable oil to prevent rust spots, so your Stanley will stay in good condition until you need it again.

### **EFFICIENT ECONOMICAL USE OF WOOD**

Wood combustion occurs in three stages. First the moisture is evaporated (converted to steam), then the volatiles are distilled and finally the fixed carbon (charcoal) is burned. All stages of combustion can occur at the same time, such as when fresh fuel is added to the glowing embers.

Moisture must be evaporated and dispersed before wood will burn. Consequently, wood should be cut and dried for a period of several months (preferably a year) before it is used. The moisture content of some trees may be as high as 100%, i.e. equal in volume to the wood itself. After dry storage over six to ten months the moisture content will usually range from 15% to 25%. Splitting the wood prior to storage reduces drying time and this results in more even burning. It minimises condensation of the water vapour and volatile distillates, that in turn creates creosote deposits in chimney flues.

It is apparent that greater efficiency and safety will ensure from burning moderate quantities of dry wood in a hot fire than using green or wet wood that only smoulders.

The Waterford Stanley Woodburning Range ensures that air enters the fire chamber over and around the sides of the fire. This assures complete combustion which in turn minimises heat losses up the flue and reduces the amount of unburned gasses and distillates to the flue. If you have no

alternative but to use soft wood, like elder, spruce or pine, or when green wood has to be used, then the result will be low heat and the formation of much creosote. In these conditions the fire must receive plenty of draught which will help to prevent creosote forming. The Waterford Stanley Woodburning Range is sealed to prevent air leaks at the joints, consequently, wood will burn evenly by day and overnight, because of the control you can exercise over the rate of burning.

Cut your wood to size: 406mm (16") logs, which will fit the Waterford Stanley Woodburning Range fire chamber. The longer the logs the better and more enduring the fire will be.

Hardwoods are best for heat. These include: Beech, Cherry, Ash, Oak, Hickory, Hard (Sugar) Maple, Birch, Larch (Tamarack) and Elm. Elm is hard to split but is fine for a slow burning fire, and like all other woods, it is all the better for seasoning. Your hardwood ashes will benefit the garden; they contain valuable minerals including carbon, potash, phosphorus, copper, manganese etc. reference to the characteristics of wood are quoted from NFPA No. H8- I, 1974 (U.S.A).

### **CREOSOTE- Formation and Need for Removal**

When wood is burned slowly, it produces tar and other organic vapours, which combine with expelled moisture to form creosote. The creosote vapours condense in the relatively cool chimney flue of a slow-burning fire. As a result, creosote residue accumulates on the flue lining. When ignited this creosote makes an extremely hot fire. We suggest the chimney connector and chimney should be inspected at least twice monthly during the heating season to determine if a creosote build-up has occurred. If creosote has accumulated it should be removed to reduce the risk of a chimney fire.

Inspect the chimney connector frequently. Tap the connector with your finger when the pipe is cool. If you hear a dull echo, the pipe may need cleaning. Disassemble the chimney connector and clean the sections. Replace corroded pipe sections. The fitting of a slip-joint in the stove pipe makes the dismantling easy for cleaning and inspection of chimney and stove.

When inspecting a masonry chimney, start at the clean-out door, normally found in the basement, at the base of the chimney, or on the outside. If your chimney does not have a clean-out door it must be inspected and cleaned by removing stove from chimney.

## DISPOSAL OF ASHES

Ashes should be placed in a metal container with a tight-fitting lid. The closed container of ashes should be placed on a non-combustible floor or on the ground well away from all combustible materials pending final disposal. If the ashes are disposed of by burial in soil or otherwise locally dispersed they should be retained in the closed container until all cinders have thoroughly cooled.

## HINTS ON FIRE SAFETY

To provide reasonable fire safety the following should be given serious consideration:

1. The installation of smoke detectors.
2. A conveniently located Class A fire extinguisher.
3. A practical evacuation plan.
4. A plan to deal with chimney fire as follows:
  - (a) Notify the fire department
  - (b) Prepare occupants for immediate evacuation.
  - (c) Close all openings into the stove
  - (d) While awaiting fire department, watch for ignition of adjacent combustibles from overheated stove pipe or hot embers or sparks from the chimney.

**NOTE:** Inspect the chimney flue weekly until a safe frequency is established.

## FUELS

Wood logs up to 406 mm (16").

## LIGHTING THE FIRE

Open the fire door (Part no. 57), lay a few crumpled sheets of paper on the bottom grate (Part no. 41) then a few small dry pieces of sticks or kindling. Open the spin wheel (Part no. 58) fully by rotating it in an anti-clockwise direction. Turn the direct damper (Part no. 63) to open by using the operating tool. Now light the paper, close the fire door (Part no. 57) when the kindling has caught fire (allow 15 minutes for this to happen) add larger pieces of dry wood, until the fire box is half filled. When the larger pieces of wood have caught fire, add full sized logs.

**IMPORTANT: UNDER NO CIRCUMSTANCES SHOULD ANY FLAMMABLE LIQUID, GASOLINE KEROSENE, LIGHTER FLUID OR CHARCOAL-STARTERS BE USED TO LIGHT OR "FRESHEN UP" THE FIRE. NEVER USE MANUFACTURED LOGS. OPERATE APPLIANCE ONLY WITH FUELLING DOOR AND ASHPIT DOOR CLOSED.**

**"KEEP ALL SUCH LIQUIDS WELL AWAY FROM STOVE WHILE IN USE"**

**OPERATE APPLIANCE ONLY WITH FUELLING DOOR AND ASHPIT DOOR CLOSED.**

Fig. 16

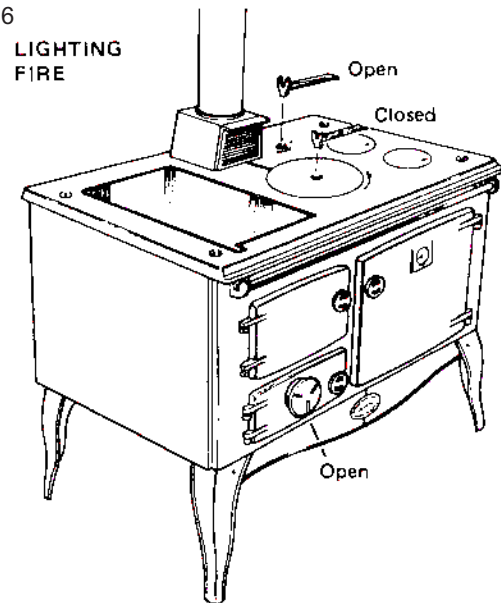

## CONTROLLING THE FIRE

The chimney damper must be kept closed except when lighting the fire. Combustion is governed by using the spin-wheel (Part No. 58) which controls both primary and secondary air supply to the firebox. The oven damper (Part No. 63) under the round hot-plate (Part No. 20) reduces the chimney draught. You will get to know how to use the spin-wheel (Part No. 58) and the oven damper (Part No. 63) in conjunction for the best results. Remember NOT to try to get a quick temperature increase by opening the chimney damper. Keep the ashpit door (Part No. 3) closed securely except when de-ashing the fire. Keep the fire door (Part No. 57) closed securely except when fuelling from the front. Loading frequency of the fuel depends on burn rate. Once they are well alight, logs need little draught to maintain combustion.

**KEEP ALL COMBUSTIBLE MATERIALS AT LEAST 1220mm (4 feet) AWAY FROM THE RANGE.**

They include rugs, fabrics, furnishings, papers, fire-wood, etc. **NEVER** dry clothing on or within 1220mm (4 feet) of the range.

## THE HOTPLATE

Use the hotplate and the cooking-top of the range for boiling, simmering, frying, grilling, braising, etc. Best results can be obtained by using flat bottomed utensils. The lacquer which was applied to protect the surface-ground hotplates will burn off. Keep the hotplates clean with a wire brush. Over a short period you will quickly adapt to the best ways and means of using the cooker-top in order to obtain utmost satisfaction and efficiency.

## THE OVEN

When the oven is required for baking, roasting, or casseroles, open the oven dampers (Part No. 63) and the spin-wheel (Part No. 58) until the oven thermometer (Part No. 74) shows a temperature of about 25 C below that required. Then adjust the oven damper (Part No. 63) to reach the required temperature without exceeding it. A little practice will soon show how much adjustment is necessary.

## OVERNIGHT BURNING

The correct setting for the spin-wheel (Part No. 58) and the oven damper (Part No. 63) for overnight burning can be found by experimenting. The following routine should give the requirement. (If it does not, the spin-wheel or the damper can be closed more for another attempt). Open the spin-wheel (Part No. 58) a quarter of a turn and close the oven damper (Part No. 63) to one quarter of its maximum opening. Lightly riddle the fire bottom bar and re-fuel with logs until the firebox is full. In the morning open the spin-wheel (Part No. 58) and oven damper (Part No. 63). Lightly riddle the fire. When the fire is burning well, top up with logs.

## RIDDLING

Open the ashpit door (Part No. 3). Use the operating tool (Part No. 30) to lightly move the bottom grate (Part No. 41) to and fro. Empty the ash pan (Part No. 70) as required. Always close the ash-pit door tightly.

## FLUE CLEANING

Open the oblong hot plate (Part No. 19). Remove the simmering/oven hob cleaning cups (Part No. 15), open the direct damper (Part No. 14). Brush deposits on the oven top into the fire box, brush downwards the deposits in the space both behind and at the side of the oven. Remove the cleaning door (Part No. 59) from below the oven door (Part No. 2). Rake the deposits through from underneath the oven towards the front and out through the cleaning aperture in the cooker front (Part No. 1) into a container.

## CHIMNEY CLEANING

Inspect the chimney connector frequently. Tap the connector with your finger when the pipe is cool. If you hear a dull echo, the pipe may need cleaning. Disassemble the chimney connector and clean the sections. Replace corroded pipe sections, the fitting of a slip-joint in the stove pipe makes the dismantling easy for cleaning and inspection of chimney and stove.

When inspecting a masonry chimney, start at the clean-out door, normally found in the basement, at the base of the chimney, or on the outside. If the chimney does not have a clean-out door it must be inspected and cleaned by removing the stove from the chimney.

## USE OF TOOLS

Fig. 17

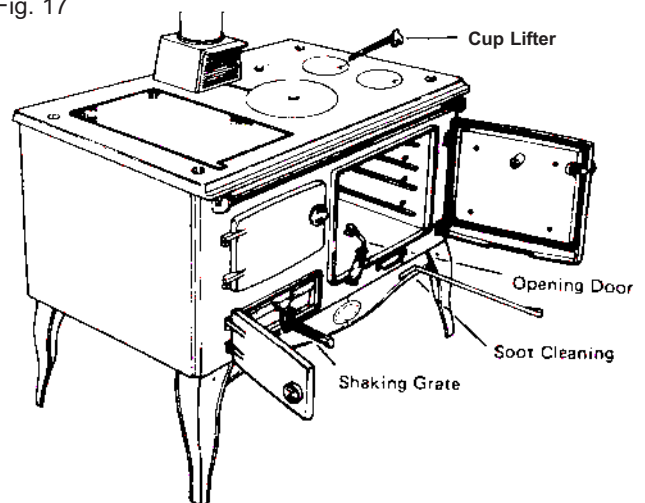

## VITREOUS ENAMEL CLEANING

**General cleaning must be carried out when the stove is cool.**

If this stove is finished in a high gloss vitreous enamel, to keep the enamel in the best condition observe the following tips:

1. Wipe over daily with a soapy damp cloth, followed by a polish with a clean dry duster.
2. For stubborn deposits a soap impregnated pad can be carefully used on the vitreous enamel.
3. **DO NOT USE ABRASIVE PADS OR OVEN CLEANSERS CONTAINING CITRIC ACID ON ENAMELLED SURFACES. ENSURE THAT THE CLEANSER MANUFACTURERS INSTRUCTIONS ARE ADHERED TO.**

# WARMING SHELF - LEFT OR RIGHT HAND LOCATION

## ASSEMBLY INSTRUCTIONS

1. Remove the  $\frac{1}{4}$ " (6mm) x  $\frac{1}{4}$ " (6mm) round head screws (2 off) from the hob and  $\frac{1}{4}$ " (6mm) x  $\frac{1}{4}$ " (6mm) round head screw (1 off) from the front and dispose of (used for packing purposes only).
2. Bolt the bracket (2) to the Warming Shelf (1) using the  $1\frac{1}{2}$ " (38mm) x  $\frac{1}{4}$ " (6mm) csk screw (6) and the 1" (25mm) x  $\frac{1}{4}$ " (6mm) hex head bolt (9) and  $\frac{3}{8}$ " washers (10 provided).
3. Place the Warming Shelf beside the hob (3) keeping the top face flush with the hob top and in line with the front of the hob.
4. Attach Warming Shelf to hob with  $\frac{1}{2}$ " (12mm) x  $\frac{1}{4}$ " (6mm) hex head bolts (8) provided and fit 1" (25mm) x  $\frac{1}{4}$ " (6mm) round head screw (7) to front.
5. Tighten all screws.

## CONTENTS

1. Warming Shelf (1 off).
2. Bracket to Shelf (1 off).
3. Hob of Stove.
4. Front of Stove.
5. Side of Stove.
6.  $1\frac{1}{2}$ " (38mm) x  $\frac{1}{4}$ " (6mm) csk chrome plated (1 off).
7. 1" (25mm) x  $\frac{1}{4}$ " (6mm) R.H. chrome plated (1 off).
8.  $\frac{1}{2}$ " (12mm) x  $\frac{1}{4}$ " (6mm) hex head bolts (2 off).
9. 1" (25mm) x  $\frac{1}{4}$ " (6mm) hex head bolts (1 off).
10.  $\frac{3}{8}$ " (9mm) Washers (2 off).

Fig. 18

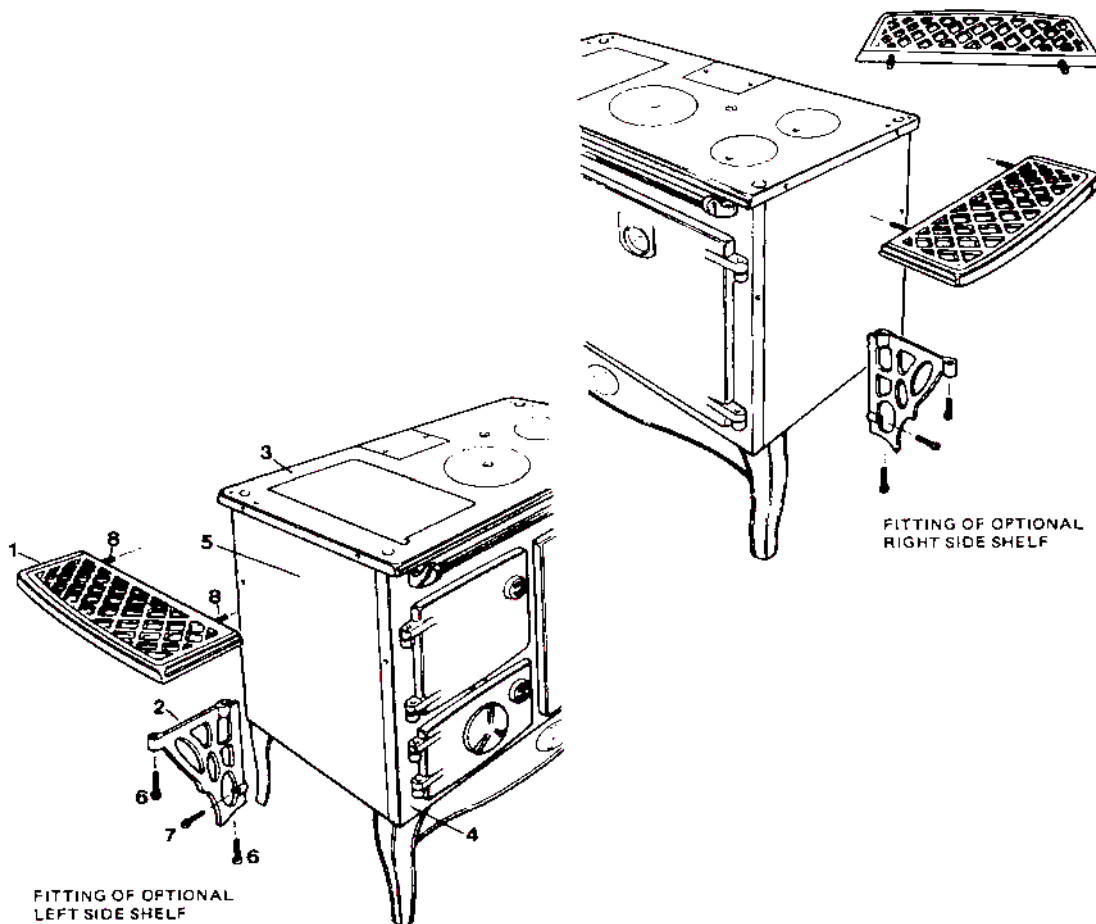

## ASSEMBLY INSTRUCTIONS - WARMING OVEN

1. Your warming oven is supplied in a part assembled condition.
2. The oven is complete and the splashback, top rail, top rail brackets and side brackets are separate components complete with 4 No. short (M5 x 12) set screws and 4 No. long (M5 x 20) set screws all with washers.
3. To assemble on a WOODSTANLEY already installed with a top flue outlet proceed as follows:
  - (a) Remove the inside top bolts of the warming oven and fit the top rail between the brackets. Place the brackets on top of the warming oven and replace the bolts.
  - (b) Dismantle, clean and remove flue pipe.
  - (c) Remove the four screws from the hob and place the side brackets, with the flat surfaces outwards, on the hob. Replace the screws but do not tighten them.
  - (d) Slide flue through warming oven and loosely fit warming oven to brackets using long set screws (M5 x 20). Reassemble flue.
  - (e) Remove the two small set screws (M5 x 12) from both sides of back of warming oven and fit splash back using the extra set screws (M5 x 12) to bolt splash back to side brackets.
  - (f) **TIGHTEN ALL BOLTS.** Your warming oven is now ready for use.

Fig. 19

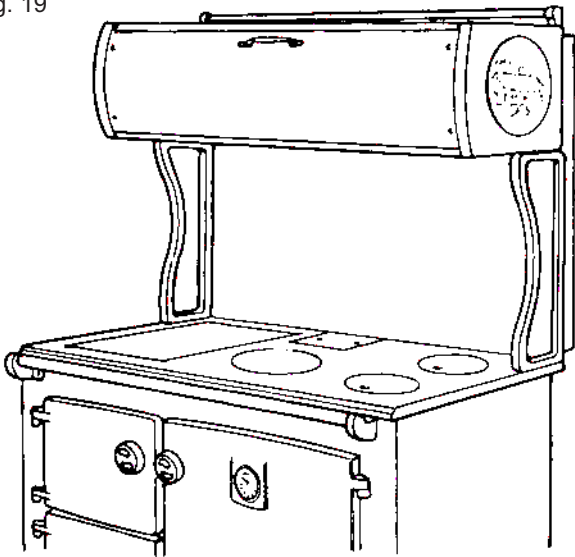
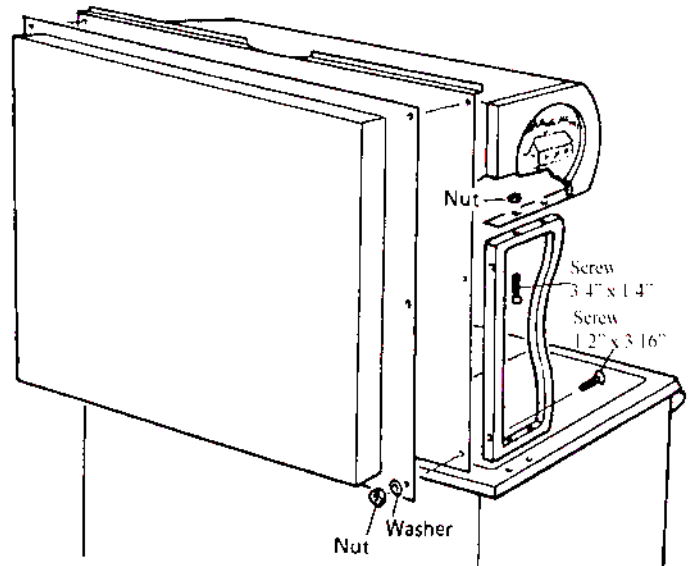
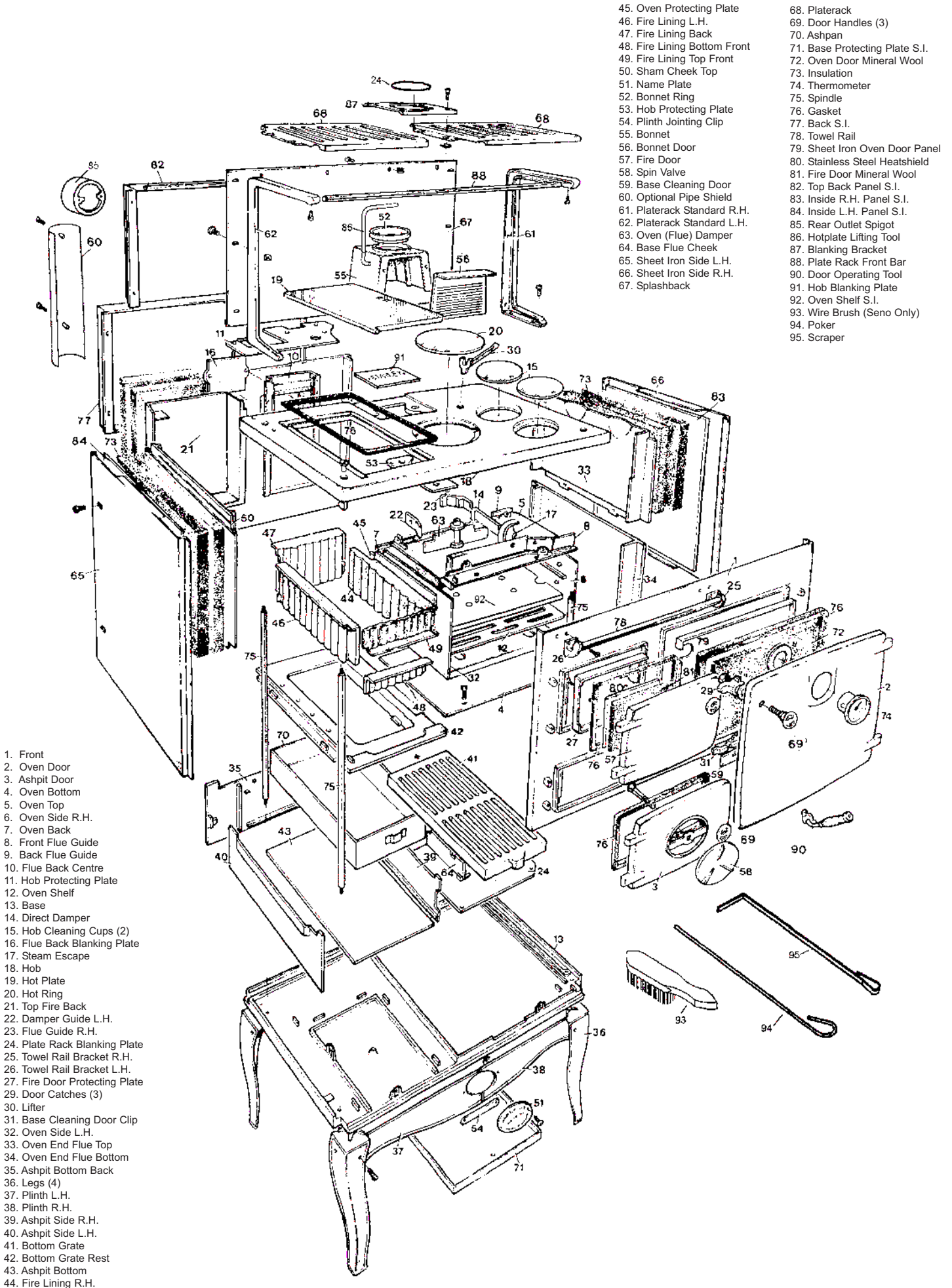

Fig. 20



# EXPLODED VIEW



# WARRANTY

## CONDITIONS OF WARRANTY

Your Stanley cooker is guaranteed against any part that fails (under normal operating conditions) from the date of installation of the appliance. If the unit is not installed within six months of date of purchase, the warranty will commence six months from the date of purchase. The warranty is given only to the original consumer/purchaser only and is non-transferable. The appliance must be installed by a suitable qualified person and installed as per the requirements of this manual. Failure to comply with the installation requirements will void your warranty. Waterford Stanley reserve the right to replace any part due to manufacturing defect that fails within the warranty period under the terms of the warranty. All Oil & Gas appliances must be commissioned by an authorised Stanley Engineer to validate your warranty. The unit must be used for normal domestic purposes only and in accordance with manufacturer's operation instructions.

## LIMITS OF LIABILITY

*The warranty does not cover:*

- \* Special, incidental or consequential damages, injury to persons or Property, or any other consequential loss.
- \* Any issue with caused by negligence, misuse, abuse or circumstances beyond Waterford Stanley's control.
- \* Any issue with wear and tear, modification, alteration, or servicing by anyone other than an authorised service engineer.
- \* Installation and operational related problems such as draught related issues external to the cooker, inadequate venting or ventilation, excessive flue offsets, negative air pressure caused by insufficient burning of improper fuel.
- \* Damage caused to the unit while in transit.
- \* Enamel discolouration due to over firing, enamel damage caused by impact, damage to baffles caused by over firing and fading of surface finish on casting.
- \* Stress fractures on bricks.
- \* Rust on cast iron parts unless reported prior to unit being installed.

**Note:** Adequate clearance must be maintained around the appliance to ensure the ease of part removal in the possible event of their damage/failure. Waterford Stanley are not responsible for any costs incurred in the removal of items installed in the vicinity of the appliance that have to be moved to facilitate a part replacement.

All warranty claims must be reported to the Waterford Stanley Service Department and must be submitted with the product serial number (located on the front casting), date of purchase, proof of purchase (if requested) and details of the specific nature of the problem.

**Manufactured by**  
**Waterford Stanley Ltd.,**  
Unit 210, IDA Industrial Estate, Cork Road,  
Waterford, Ireland.  
Tel: (051) 302300 Fax (051) 302315  
Website: [www.waterfordstanley.com](http://www.waterfordstanley.com)

