

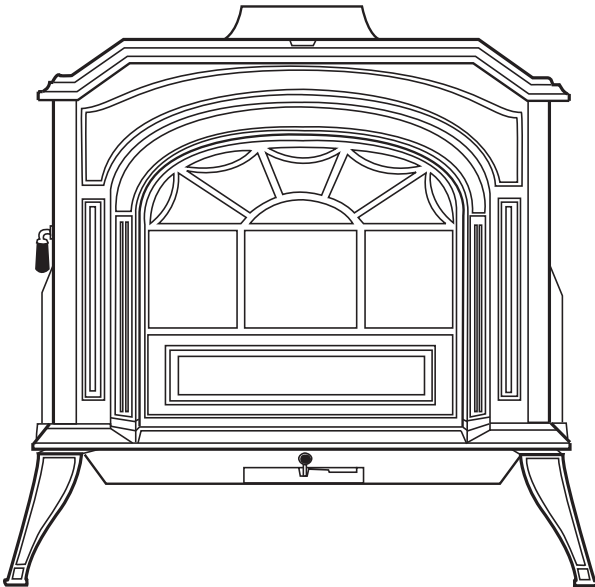

# Resolute® Acclaim Woodburning Stove



**Model 2490**

## Homeowner's Installation and Operating Manual

For use in the  
United States and Canada

**SAFETY NOTICE: IF THIS APPLIANCE IS NOT PROPERLY INSTALLED, OPERATED AND MAINTAINED, A HOUSE FIRE MAY RESULT. TO REDUCE THE RISK OF FIRE, FOLLOW THE INSTALLATION INSTRUCTIONS. FAILURE TO FOLLOW INSTRUCTIONS MAY RESULT IN PROPERTY DAMAGE, BODILY INJURY OR EVEN DEATH. CONTACT LOCAL BUILDING OFFICIALS ABOUT RESTRICTIONS AND INSTALLATION INSPECTION REQUIREMENTS IN YOUR AREA.**

**NATIONAL  
FIREPLACE  
INSTITUTE**



**CERTIFIED**  
[www.nficertified.org](http://www.nficertified.org)

We recommend that our woodburning hearth products be installed and serviced by professionals who are certified in the U.S. by the National Fireplace Institute® (NFI) as NFI Woodburning Specialists or who are certified in Canada by Wood Energy Technical Training (WETT).



**Do Not Discard This Manual: Retain for Future Use**

## Introduction

Thank you for choosing a Vermont Castings Resolute Acclaim.

Your stove is one of the finest available. It features high efficiency, non-catalytic performance, using space-age refractory material and the precisely calibrated delivery of air to a concentrated charcoal bed to promote secondary combustion in a controlled environment.

If treated properly and operated according to the guidelines in this manual it will provide years of safe, dependable, and economical heating.

The Resolute Acclaim is listed by OMNI-Test Laboratories of Portland, Oregon. The test standards are ANSI/UL-1482 and 737 for the United States and ULC S627 for Canada.

The Resolute Acclaim is listed for burning wood. Do not burn other fuels.

The Resolute Acclaim is listed and approved for installation in mobile homes only in the United States and only with use of Vermont Castings Mobile Home Installation Kit #3249.

The Vermont Castings Resolute Acclaim is in compliance with the standards set forth by the Federal Environmental Protection Agency, 40 CFR Part 60.532(b)(2), as stated on the permanent label attached to each stove.

In addition to directions on installation and operation, this manual includes directions on maintenance and assembly.

We recommend that you hire a professional solid fuel stove installer to install your stove, or to advise you on the installation should you attempt to install it yourself.

### Save These Instructions.

#### Table of Contents

Specifications .....	3
Installation .....	4
Operation.....	17
Maintenance.....	24
Replacement Parts.....	29

**Proposition 65 Warning:** Fuels used in gas, woodburning or oil fired appliances, and the products of combustion of such fuels, contain chemicals known to the State of California to cause cancer, birth defects and other reproductive harm.  
California Health & Safety Code Sec. 25249.6

#### Accessories

Warming Shelf  
#0064 Classic Black  
#1385 Biscuit  
#1395 Brown Majolica  
#1397 Bordeaux  
  
#0184 Rear Heat Shield  
#0246 Bottom Heat Shield  
#0133 Sparkscreen  
#3255 Outside Air Adapter (for 3" ducting)  
#3249 Mobile Home Kit - includes: Rear and Bottom Heat Shields, Outside Air Adapter, Ducting and Leg Clips  
#0574 Stove Surface Thermometer  
#3421 Gasket Kit  
#4360 Griddle Handle Kit

# Specifications

## Resolute Acclaim Model 2490

Range of heat output.....	9,500-33,900 BTU/hr.*
EPA Emissions Rating.....	3.4g/hr*
Maximum heat output.....	40,000 BTU/hr.**
Area heated***.....	Up to 1600 sq. ft. (148 sq m)
Fuel size/type.....	16" (410 mm) wood splits
Fuel capacity.....	30 lbs. (13.6 kg)
Loading.....	Front or top
Chimney connector.....	6" (152 mm) diameter
Chimney flue size.....	Min. 6" (152 mm) or 8" (203 mm)
Flue exit position.....	Reversible, top or rear
Primary air.....	Manual
Secondary air.....	Preset
Ash handling system.....	Removable ash pan
Glass panel.....	High-temperature ceramic
Weight.....	425 lbs. (192 kg)
Width (leg-to-leg).....	26" (660 mm)
Depth (leg-to-leg).....	19" (480 mm)
Height to top of flue collar:	
w/Regular legs.....	27½" (699 mm) top exit
.....	25" (635 mm) rear exit
w/Short legs.....	25½" (648 mm) top exit
.....	23" (584 mm) rear exit

\*Under specific conditions used during EPA emissions testing.

\*\*This value can vary depending on how the unit is operated, and the type and moisture content of the fuel used. Figure shown is based on maximum fuel consumption obtained under laboratory conditions and on average efficiencies.

\*\*\*These values are based on operation in building code-conforming homes under typical winter climate conditions in New England. If your home is of non-standard construction (e.g., unusually well-insulated, not insulated, built underground, etc.) or if you live in a more severe or more temperate climate, these figures may not apply. Since so many variables affect performance, consult your Vermont Castings' Authorized Dealer to determine realistic expectations for your home.

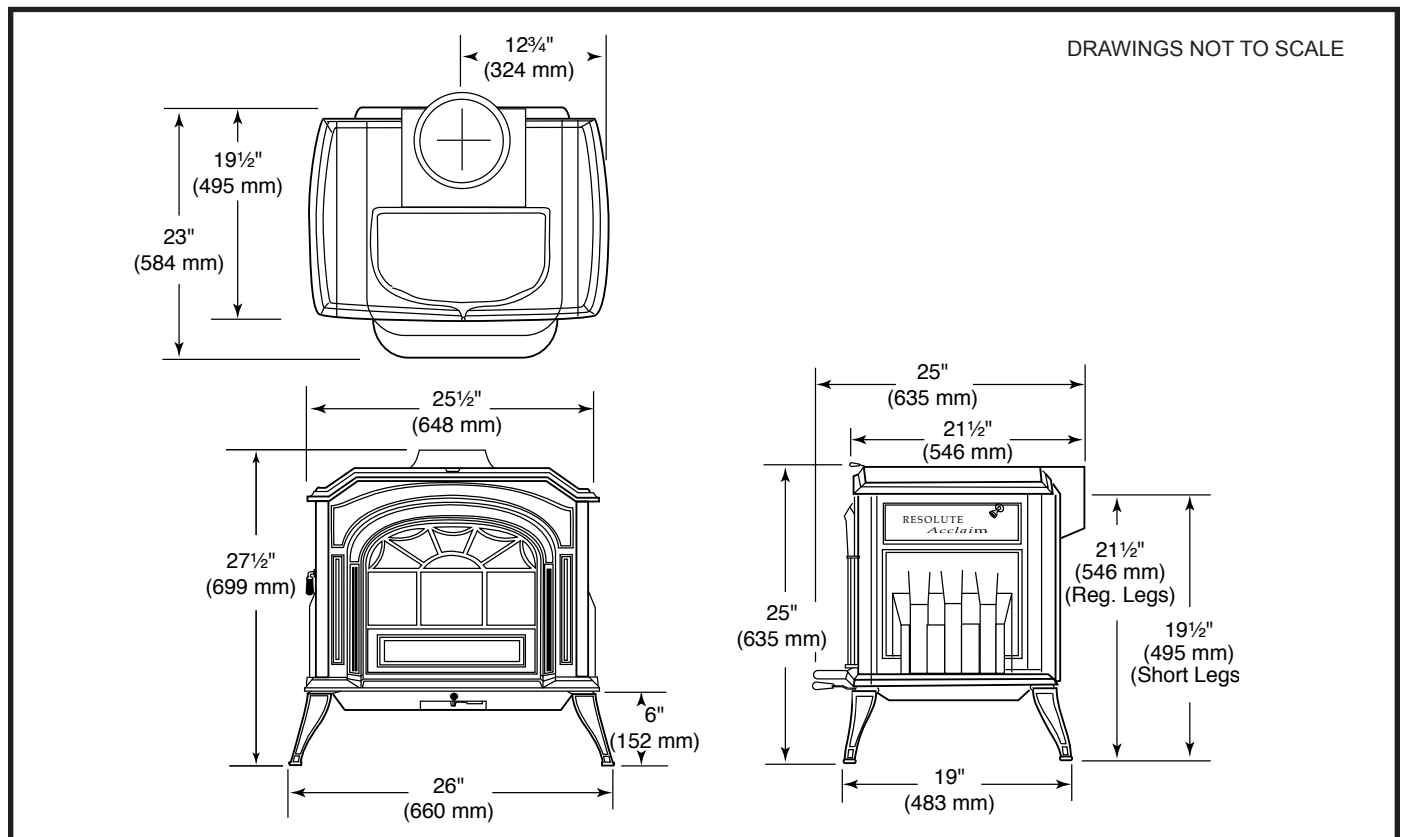

Fig. 1 Resolute Acclaim dimensions.

# Installation

**SAFETY NOTICE: IF YOUR RESOLUTE ACCLAIM IS NOT PROPERLY INSTALLED, OPERATED AND MAINTAINED, A HOUSE FIRE MAY RESULT. FOR SAFETY, FOLLOW ALL INSTALLATION, OPERATION AND MAINTENANCE DIRECTIONS. CONTACT LOCAL BUILDING OFFICIALS ABOUT RESTRICTIONS AND INSTALLATION INSPECTION REQUIREMENTS IN YOUR AREA.**

Before you begin an installation, review your plans to see that:

- Your stove and chimney connector will be far enough from combustible material to meet all clearance requirements.
- The floor protector is large enough and is constructed properly to meet all requirements.
- You have all necessary permits from local authorities.

Your local building official is the final authority for approving your installation as safe and determining that it meets local and state codes.

The metal label permanently attached to the back of every Vermont Castings stove indicates that it has been tested to current UL and ULC standards, and gives the name of the testing laboratory. Clearance and installation information is also printed on the label. Local authorities generally will accept the label as evidence that, when the stove is installed according to the information on the label and in this manual, the installation meets codes and can be approved.

Codes vary in different areas, however. Before starting the installation, review your plans with the local building authority. Your local dealer can provide any additional information needed.

For any unresolved questions about installation, refer to the National Fire Protection Association's publication ANSI/NFPA 211-1988 Standard for Chimneys, Fireplaces, Vents and Solid Fuel Burning Appliances. In Canada, the equivalent publication is CSA CAN-B365, Installation Code for Solid Fuel Burning Appliances and Equipment. These standards are the basis for many national codes. They are nationally recognized and are accepted by most local authorities. Your local dealer or your local building official may have a copy of these regulations.

**IMPORTANT: FAILURE TO FOLLOW THESE INSTALLATION INSTRUCTIONS MAY RESULT IN A DANGEROUS SITUATION, INCLUDING A CHIMNEY OR HOUSE FIRE. FOLLOW ALL INSTRUCTIONS EXACTLY AND DO NOT ALLOW MAKESHIFT COMPROMISES TO ENDANGER PROPERTY AND PERSONAL SAFETY.**

## What Kind of Chimney to Use

Your Resolute Acclaim may be connected either to a sound masonry chimney that meets local codes, to a relined masonry chimney that meets local codes, or to an approved prefabricated metal chimney. Whatever kind you use, the chimney and chimney connector must be in good condition and kept clean.

If you use an existing masonry chimney, it must be inspected to ensure safe condition before the stove is installed. Your local professional chimney sweep, building inspector, or fire department official will be able to make the inspection or to direct you to someone who can.

The chimney should extend at least 3' (914 mm) above the highest point where it passes through a roof, and at least 2' (610 mm) higher than any portion of a building within 10' (3m). (Fig. 2)

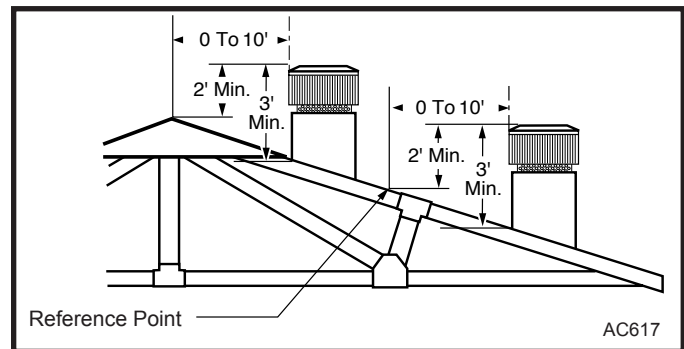

Fig. 2 The 2'-3'-10' rule for chimneys.

For proper draft and good performance, any chimney used with a Resolute Acclaim should extend at least 16' (5m) above the flue collar of the stove.

## Masonry Chimneys

An inspection of the chimney must confirm that it has a lining. Do not use an unlined chimney. The chimney also should be examined for cracks, loose mortar, other signs of deterioration, and blockage. Repair any defects before the chimney is used with your stove.

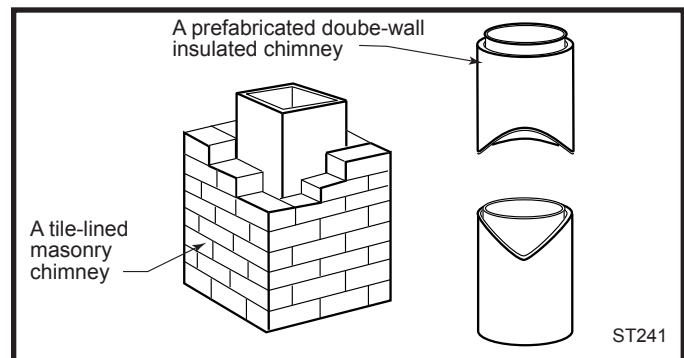

Fig. 3 Standard chimney types.

Unused openings in an existing masonry chimney must be sealed with masonry to the thickness of the chimney wall, and the chimney liner should be repaired. Openings sealed with pie plates or wallpaper are a hazard and should be sealed with mortar or refractory cement. In the event of a chimney fire, flames and smoke may be forced out of these unused thimbles.

The chimney should be thoroughly cleaned before use.

A newly-built masonry chimney must conform to the standards of your local building code or, in the absence of a local code, to a recognized national code. Masonry chimneys must be lined, either with code-approved masonry or precast refractory tiles, stainless steel pipe, or a code-approved, "poured-in-place" liner. The chimney's clean-out door must seal tightly to help ensure a good draft.

### Prefabricated Chimneys

A prefabricated metal chimney must be one tested and listed for use with solid-fuel burning appliances to the High-Temperature (H.T.) Chimney Standard UL-103-1985 (2100°F.) for the United States, and High Temperature (650°C) Standard ULC S-629 for Canada.

**DO NOT CONNECT THIS UNIT TO A CHIMNEY FLUE SERVING ANOTHER APPLIANCE.**

### Chimney Size

A Resolute Acclaim is approved for venting into a masonry chimney with a flue size of 8" x 8" (203 x 203 mm), and into a round flue size of 8" (203 mm) or 6" (152 mm).

It may be vented into larger chimneys as well. However, chimneys with liners larger than 8" x 12" (203 x 305 mm) may experience rapid cooling of smoke and reduction in draft, especially if they are located outside the home. These large chimneys may need to be insulated or to have their flues relined for proper stove performance.

Accessories to help make the connection between stainless steel chimney liners and your Resolute Acclaim are available through your local dealer.

### Chimney Connector Guidelines

A chimney connector is the double-wall or single-wall pipe that connects the stove to the chimney. The chimney itself is a masonry or prefabricated structure that encloses the flue. Chimney connectors are used only to make the connection from the stove to the chimney. They are for interior use only.

Double-wall connectors must be tested and listed for use with solid-fuel burning appliances. Single-wall connectors should be made of 24 gauge or heavier steel, and should be 6" (152 mm) in diameter. Do not use galvanized chimney connector; it cannot withstand the high temperatures that can be reached by smoke and exhaust gases, and may release toxic fumes under high heat.

If possible, do not pass the chimney connector through a combustible wall or ceiling. If passage through a combustible wall is unavoidable, refer to the recommendations in the section following on Wall Pass-Throughs. Do not pass the connector through an attic, a closet or any similar concealed space. The whole chimney connector should be exposed and accessible for inspection and cleaning.

Install the chimney connector not less than 23" (584 mm) from the ceiling. Keep it as short and direct as possible, with no more than two (2) 90° turns. If possible, use 45° elbows. Slope horizontal runs of connectors upward 1/4" per foot (20 mm per meter) going from the stove toward the chimney. The recommended maximum length of a horizontal run is 3' (914 mm), and the total length of chimney connector should be no longer than 8' (2.5 m).

In cathedral ceiling installations, extend the prefabricated chimney downward to within 8' (2.5 m) of the stove.

**SAFETY NOTE: ALWAYS WEAR GLOVES AND PROTECTIVE EYEWEAR WHEN DRILLING, CUTTING OR JOINING SECTIONS OF CHIMNEY CONNECTOR.**

### Double-wall Chimney Connectors

The listing for the Resolute Acclaim in the U.S. and Canada includes use of double-wall chimney connectors that have been tested and listed for use with solid-fuel burning appliances by a recognized testing laboratory.

Information on assembling and installing double-wall connectors is provided by the manufacturer of the double-wall pipe. Follow the manufacturer's instructions exactly as you assemble the connector and attach it to the stove and chimney. Using chimneys and connectors from the same manufacturer helps make the assembly and installation straightforward.

**NOTE: For installations using double-wall connectors, minimum clearances must conform to the listed clearances in the clearance chart on Page 12.**

### Single-wall Chimney Connectors

- Beginning at the flue collar of the stove, assemble the chimney connector. Insert the first crimped end into the stove's flue collar, and keep each crimped end pointing toward the stove. Using the holes in the flue collar as guides, drill 1/8" (3mm) holes in the bottom of the first section of chimney connector and secure it to the flue collar with three (3) #10 x 1/2" sheet metal screws.

- Secure each joint between sections of chimney connector, including telescoping joints, with at least three (3) sheet metal screws. The predrilled holes in the top of each section of chimney connector serve as guides when you drill 1/8" (3 mm) holes in the bottom of the next section.

- Secure the chimney connector to the chimney. Instructions for various installations follow.

- Be sure the installed stove and chimney connector are correct distances from nearby combustible material.

**NOTE:** Special slip pipes and thimble sleeves that form telescoping joints between sections of chimney connector are available to simplify installations. They often eliminate the need to cut individual connector sections. Consult your local dealer about these special pieces.

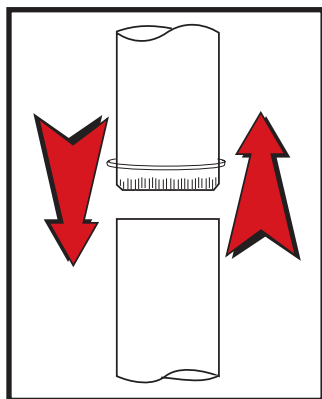

**Fig. 4** The crimped end of the connector points toward the stove.

### Securing the Single-wall Connector to a Prefabricated Chimney

Follow the installation instructions of the chimney manufacturer exactly as you install the chimney. The manufacturer of the chimney will supply the accessories to support the chimney, either from the roof of the house, at the ceiling of the room where the stove is installed, or from an exterior wall.

Special adapters are available from your local dealer to make the connection between the prefabricated chimney and the chimney connector. The top of such adapters attach directly to the chimney or to the chimney's ceiling support package, while the bottom of the adapter is screwed to the chimney connector.

These adapters are designed so the top end will fit outside the inner wall of the chimney, and the bottom end will fit inside the first section of chimney connector. When assembled in this way, any soot or creosote falling from the inner walls of the chimney will stay inside the chimney connector.

### Securing the Single-wall Connector to a Masonry Chimney

Both freestanding masonry chimneys and fireplace masonry chimneys may be used for installation of your Resolute Acclaim.

### Freestanding Installations

If the chimney connector must pass through a combustible wall to reach the chimney, follow the recommendations in the Wall Pass-Through section that follows. The opening through the chimney wall to the flue (the "breach") must be lined with either a ceramic or metal cylinder, called the "thimble", which is securely cemented in place. Most chimney breeches incorporate thimbles, but the fit must be

snug and the joint between the thimble and the chimney wall must be cemented firmly. (Fig. 5)

A special piece called the "thimble sleeve," slightly smaller in diameter than standard connector and most thimbles, will facilitate the removal of the chimney connector system for inspection and cleaning. Thimble sleeves should be available from your local dealer.

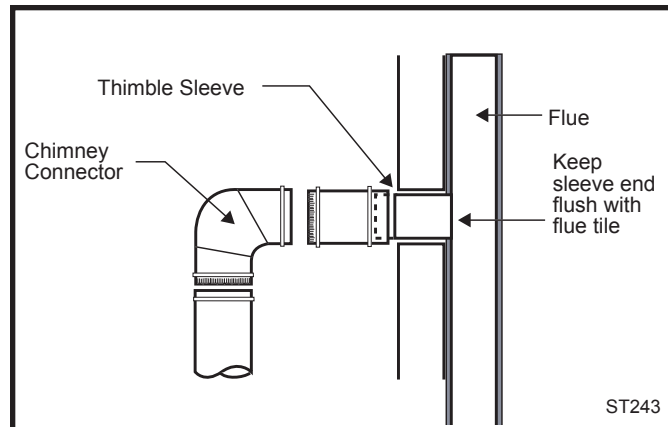

**Fig. 5** The thimble, made of either ceramic or metal, must be cemented securely in place.

To install a thimble sleeve, slide it into the breach until it is flush with the inner flue wall. Do not extend it into the actual flue passage, as this could interfere with the draft.

The thimble sleeve should protrude 1-2" (25-50 mm) into the room. Use furnace cement and thin gasketing to seal the sleeve in place in the thimble. Secure the chimney connector to the outer end of the sleeve with sheet metal screws.

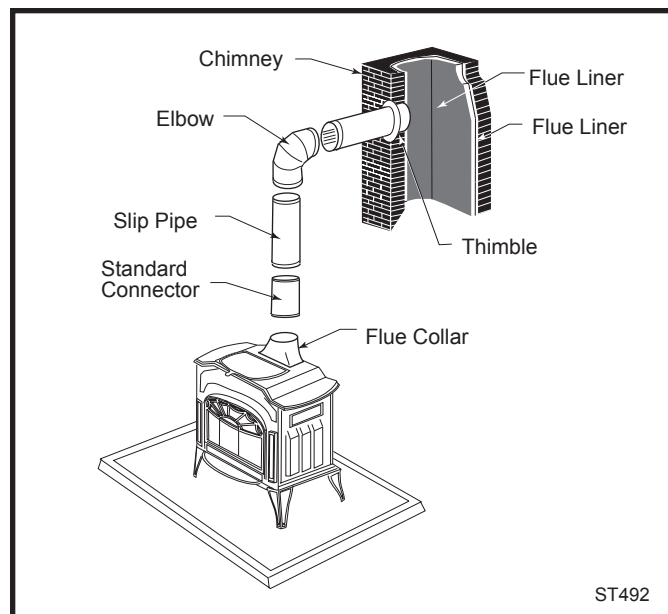

**Fig. 6** Chimney connection is a freestanding installation.

## Above A Fireplace

In this installation, the chimney connector rises from the stove, turns ninety degrees, and goes back into the fireplace chimney. (Fig. 7) The liner of the fireplace chimney should extend at least to the point at which the chimney connector enters the chimney. Follow all the guidelines for installing a chimney connector into a freestanding masonry chimney, and pay special attention to these additional points:

- If there is a combustible mantel or trim, check the stove and chimney connector clearances. Use the necessary combination of mantel, trim, and connector heat shields to provide the required clearances.
- Double-check connector clearance from the ceiling.
- The fireplace damper must be closed and sealed to prevent room air from being drawn up the flue, reducing the draft. However, it must be possible to reopen the damper to inspect or clean the chimney.

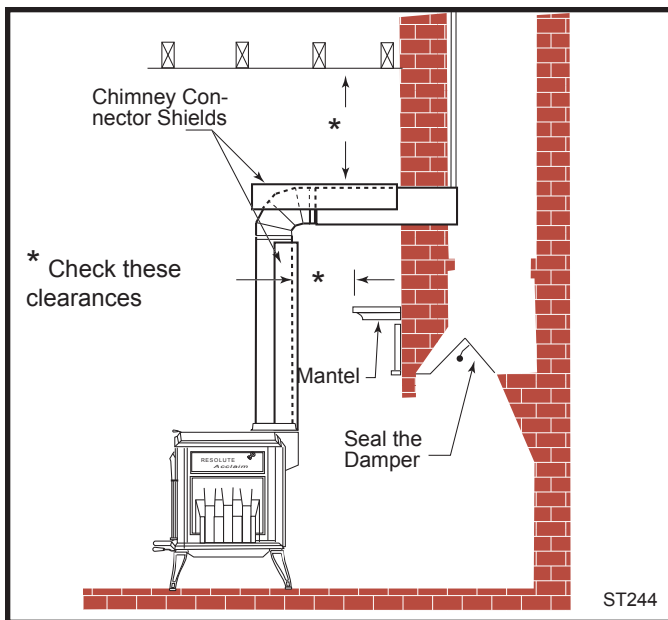

Fig. 7 Chimney connector enters chimney above the fireplace.

## Through A Fireplace

If your fireplace opening height is at least 23" (584 mm)\*, you may install a Resolute Acclaim through the opening using a "positive connection" kit available from your local dealer. These kits provide a secure connection between the stove flue collar and the chimney flue. (Fig. 8) If it is necessary to reverse the flue collar from the top exit to the rear exit position, follow the directions on Page 10.

Fireplace installations, whether connected to the flue above or through the fireplace opening, have special clearance requirements to adjacent trim and the mantel. You'll find the required safe clearances for Resolute Acclaim fireplace installations on Page 11.

Floor protection requirements also apply to fireplace installations. Floor protection is discussed on Page 9.

2000893

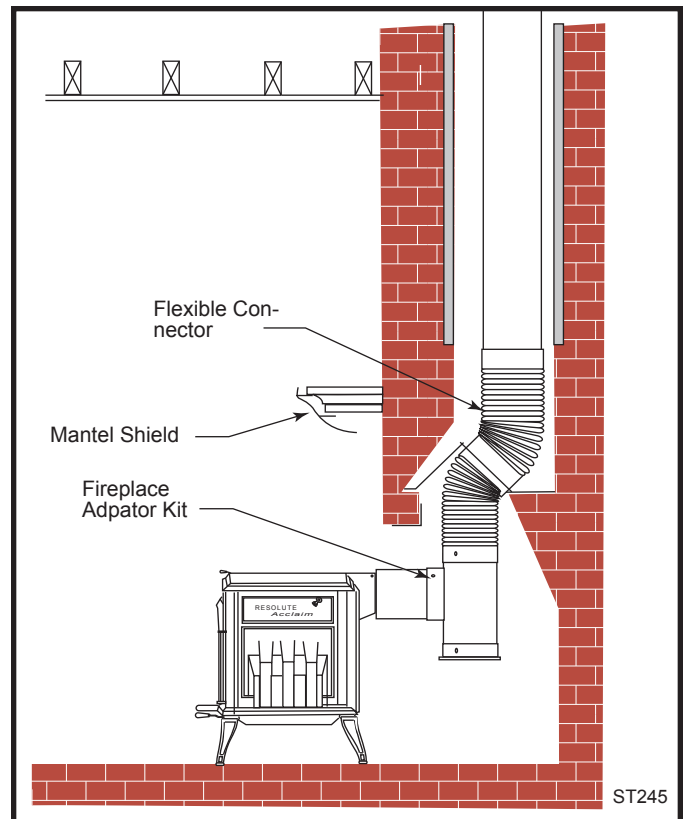

Fig. 8 Chimney connector enters chimney through the fireplace opening.

## Wall Pass-Throughs

Whenever possible, design your installation so the connector does not pass through a combustible wall. If you are considering a wall pass-through in your installation, check with your building inspector before you begin. Also check with the chimney connector manufacturer for any specific requirements.

Accessories are available for use as wall pass-throughs. If using one of these, make sure it has been tested and listed for use as a wall pass-through.

**U.S.: In the United States, the National Fire Protection Association (NFPA) has established guidelines for passing chimney connectors through combustible walls. Many building code inspectors follow these guidelines when approving installations.**

The following illustration shows one NFPA-recommended method. All combustible material in the wall is cut away a sufficient distance from the single-wall connector to provide the required 12" (305 mm) clearance for the connector. Any material used to close up the opening must be noncombustible.

Three other methods are also approved by the NFPA. These are:

- Using a section of double-wall chimney with a 9" (229 mm) clearance to combustibles.

- Placing a chimney connector pipe inside a ventilated thimble, which is then separated from combustibles by 6" (152 mm) of fiberglass insulating material.
- Placing a chimney connector pipe inside a section of 9" (229 mm) diameter, solid-insulated, factory-built chimney, with 2" (51 mm) of air space between the chimney section and combustibles.

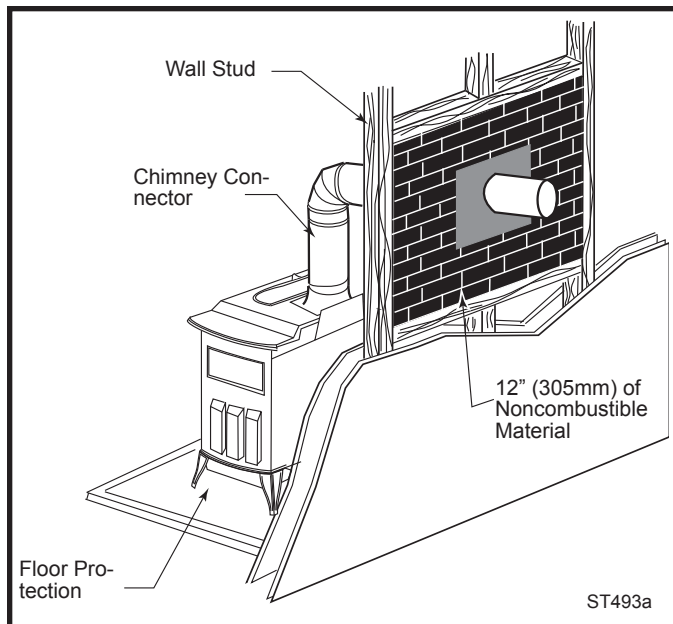

Fig. 9 An approved wall pass-through for the United States.

**Canada: The Canadian Standards Association has established different guidelines. The illustration below shows one method, in which all combustible material in the wall is cut away to provide the required 18" (457 mm) clearance for the connector. The resulting space must remain empty. A flush-mounted sheet metal cover may be used on one side only. If covers must be used on both sides, each cover must be mounted on noncombustible spacers at least 1" (25 mm) clear of the wall. Your local dealer or your local building inspector can provide details of other approved methods of passing a chimney connector through a combustible wall.**

In Canada, this type of installation must conform to CAN/CSA-B365, Installation Code for Solid Fuel Burning Appliances and Equipment.

**NOTE: Do not vent your Resolute Acclaim into a factory-built (zero-clearance) fireplace under any circumstances. The Resolute Acclaim has not been specifically tested and listed for this type of installation.** These appliances and their chimneys are specifically designed as a unit for use as fireplaces. It may void the listing or be hazardous to adapt them for any other use.

**DO NOT CONNECT THE RESOLUTE ACCLAIM TO ANY AIR DISTRIBUTION DUCT OR SYSTEM.**

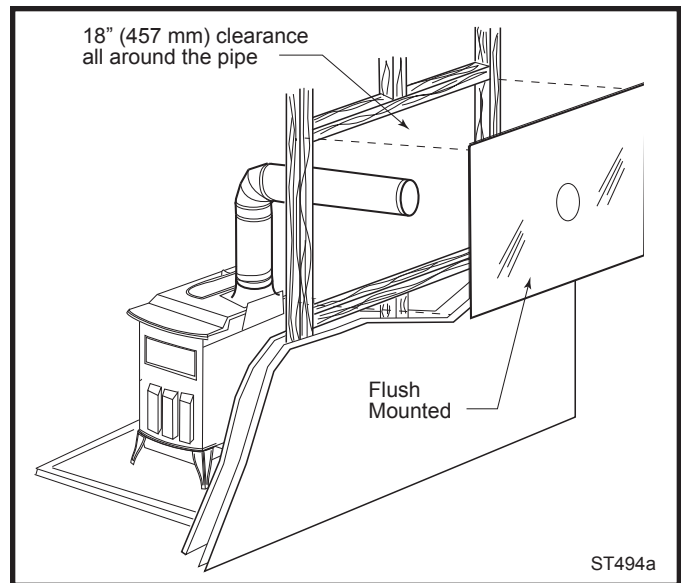

Fig. 10 An approved wall pass-through for Canada.

## Floor Protection

A tremendous amount of heat radiates from the bottom plate of your Resolute Acclaim. The floor area directly under and around the stove will require protection from radiant heat as well as from stray sparks or embers that may escape the firebox.

Heat protection is provided through the use of a Vermont Castings Bottom Heat Shield #0246. Spark and ember protection must be provided by a floor protector constructed with noncombustible material as specified.

Most installations will require that the bottom heat shield be attached. Only when the stove is placed on a completely noncombustible surface such as unpainted concrete over earth may it be used without the heat shield.

Even when the bottom heat shield is installed, you must provide special protection to the floor beneath. For installations with the heat shield attached, use a noncombustible floor protector such as 1/4" non-asbestos mineral board or equivalent, or 24 gauge sheet metal. The floor protector may be covered with a noncombustible decorative material if desired. Do not obstruct the space under the heater.

Protection requirements vary somewhat between the United States and Canada as follows:

**U.S. installations** the floor protector is required under the stove and must extend at least 16" from the front of the stove ("C", Fig. 11), and at least 6" from the sides and rear ("D" and "E", Fig. 11). It must also extend under the chimney connector and 2" to either side ("F", Fig. 11).

To meet these requirements, a floor protector must be at least 38" wide and 42" deep.

**In Canada,** a noncombustible floor protector is required under the heater also. The floor protector must extend 18" (457 mm) to the front ("C", Fig. 11), and 8" (203 mm) from the sides and rear ("D" and "E", Fig. 11).



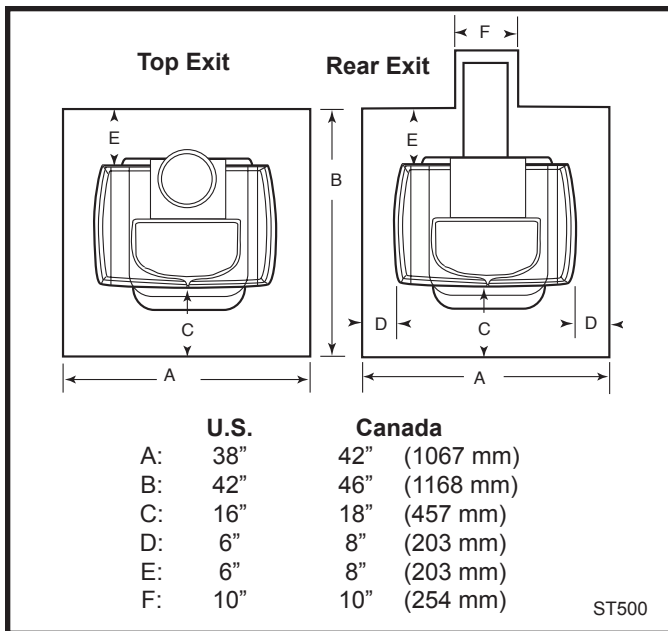

Fig. 11 Required floor protector dimensions.

To meet these requirements, a floor protector must be at least 42" (1067 mm) wide and 46" (1168 mm) deep.

### Floor Protection for Fireplace Installation

Do not assume that your fireplace hearth is completely noncombustible

Many fireplace hearths do not satisfy the "completely non-combustible" requirement because the brick or concrete in front of the fireplace opening is supported by heavy wood framing as in Figure 12. Because heat passes readily through brick or concrete, it can easily pass through to the wood. As a result, such fireplace hearths can be a fire hazard and are considered a combustible floor.

For all fireplace installations, follow the floor protection guidelines described above.

Keep in mind that many raised hearths will extend less than the required clearance from the front of the heater when it is installed. In such cases, sufficient floor protection as described above must be added in front of the hearth to satisfy the minimum floor protector requirement from the front of the stove: 16" (410 mm) from the front in the United States and 18" (457 mm) from the front in Canada.

Hearth rugs do not satisfy the requirements for floor protection as they are not fire proof.

Fireplace installations also have special clearance requirements to the side walls, side decorative trim, and fireplace mantel. Refer to the information on fireplace and mantel trim shields in this section.

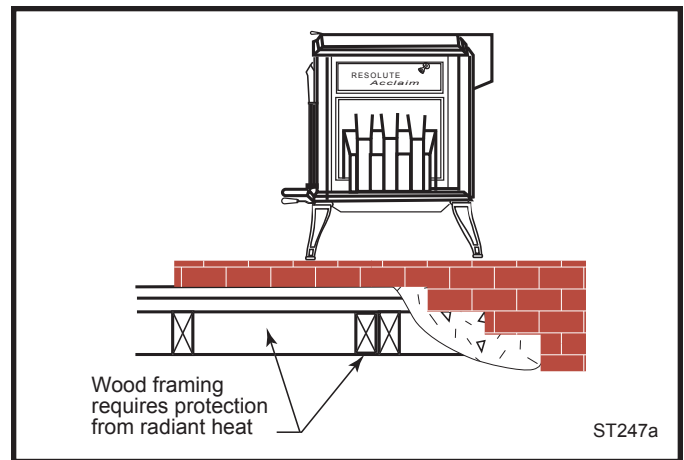

Fig. 12 Supporting timbers under fireplace hearth are considered to be combustible

### Keep the Stove a Safe Distance From Surrounding Materials

Both a stove and its chimney connector radiate heat in all directions when operating. A safe installation requires that adequate clearance be maintained between the stove and nearby combustible materials to ensure that such materials do not overheat.

Clearance is the distance between either your stove or chimney connector, and nearby walls, floors, the ceiling, and any other fixed combustible surface. Keep furnishings and other combustible materials away from the stove as well. In general, a distance of 48" (1220 mm) must be maintained between the stove and moveable combustible items such as drying clothes, furniture, newspapers, firewood, etc. Keeping those clearance areas empty assures that nearby surfaces and objects will not overheat.

### Safe Ways to Reduce Clearances

Your stove has special clearance requirements that have been established after careful research, and testing to UL and ULC standards.

Clearance requirements have been established to meet most installation possibilities, and they involve the combination of four basic variables:

- When the stove has no listed heat shield mounted on it.
- When the stove has a listed heat shield mounted on it.
- When the wall has no listed heat shield mounted on it.
- When the wall has a listed heat shield mounted on it.

In general, the greatest clearance is required when you are placing a stove with no heat shield near a wall with no heat shield. The least clearance is required when both the stove and the wall have heat shields. Reducing a stove clearance may require a listed heat shield on the chimney connector as well.

Clearances may be reduced only by means approved by the regulatory authority, or in accordance with the clearances listed in this manual.

## Wall Shields

Wall shields should be constructed of 24 gauge or heavier sheet metal, or another noncombustible material such as 1/2" (13 mm) insulation board or common brick "laid on flat," with the 3 1/2" (89 mm) side down. (Fig. 13)

Shields must be spaced out from the combustible surface 1" (25 mm) on noncombustible spacers. The spacers should not be directly behind the stove or chimney connector.

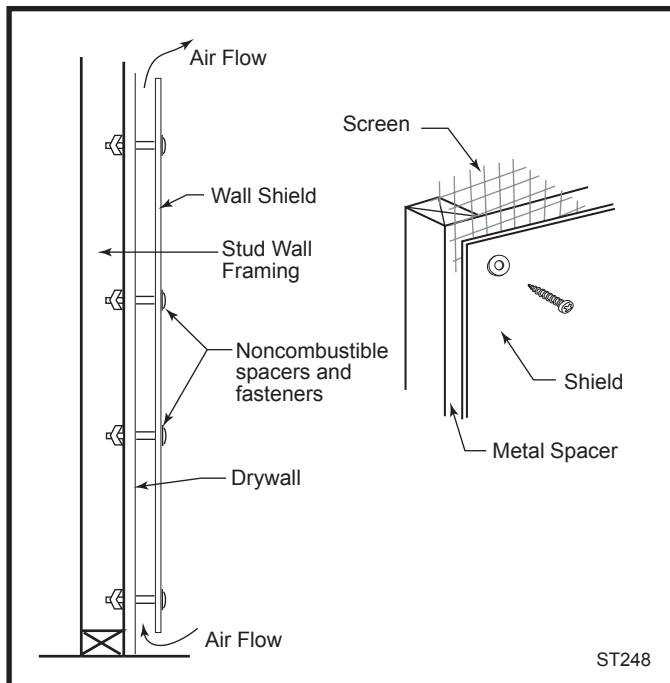

Fig. 13 Approved wall shield construction.

Air must be able to flow between the wall and the shield. At least 50% of the bottom 1" (25 mm) of the shield should be open and the shield must be open at the top.

When calculating clearance, always measure from the top plate of the stove, or, from the chimney connector itself, to the adjacent combustible surface. Do not measure from the heat shields of the stove or connector to the combustible surface.

## Reversing the Flue Collar

Your Resolute Acclaim is shipped with the flue collar in the top exit position. Depending on your requirements, you may wish to reverse the flue collar and extension plate to the rear exit position. The only tool necessary is a 7/16" wrench.

To reverse the flue collar position:

1. Remove the four (4) fasteners that hold the collar and extension plate. The fasteners are accessible by reaching through the flue collar of the stove.

2. Remove the flue collar and extension plate.
3. Examine the exposed gasket; contact your Vermont Castings Authorized Dealer if the gasket needs to be replaced.
4. Position the extension plate and flue collar in the appropriate orientation, making sure the gasket remains in place. The notched edge of the extension plate should be next to the griddle.
5. Secure the extension plate and flue collar with the fasteners removed in the first step. Run the bolts in only finger-tight. Adjust the fit of the extension plate and/or flue collar if necessary. Tighten all four (4) fasteners, but do not overtighten them. Test the action of the griddle; make any needed adjustments by loosening the hardware, repositioning the flue collar and extension plate, retesting the griddle action, and retightening the hardware.

## Fireplace Installations

A fireplace installation requires special clearance between the side of the stove and the right and left walls, the side of the stove and the decorative side trim on the fireplace face, and the top of the stove and the mantel.

Ventilated shields (noncombustible) installed on noncombustible spacers 1" (25 mm) away from the combustible surface may be used to reduce clearances. (Fig. 14) A mantel shield for the Resolute Acclaim must be at least 48" (1219 mm) long, centered over the stove. Side trim shields must extend the full length of the trim. (Fig. 15)

An unprotected mantel ("A", Fig. 15) must have a minimum clearance of 36" (914mm), measured from the stove's top plate. With a ventilated shield the clearance may safely be reduced to 30" (762 mm). Maximum depth of the mantel is 9" (229 mm).

Unprotected top trim (B) protruding 1 1/2" (38 mm) or less from the face of the fireplace must be a minimum of 28" (711 mm) from the stove's top surface. This clearance may not be reduced by shielding. If top trim protrudes more than 1 1/2" (38 mm) the mantel clearances of 36" (915mm) unshielded and 30" (762 mm) shielded must be used.

Side trim must have a minimum clearance of 8" (203 mm), measured from the stove's top side edge. In this case, ventilated shielding will not provide protection to allow clearance reduction.

In addition, a fireplace installation must observe the floor protection guidelines discussed previously.

The charts and sample installations on the following pages list the clearances required for various installation configurations of the Resolute Acclaim.

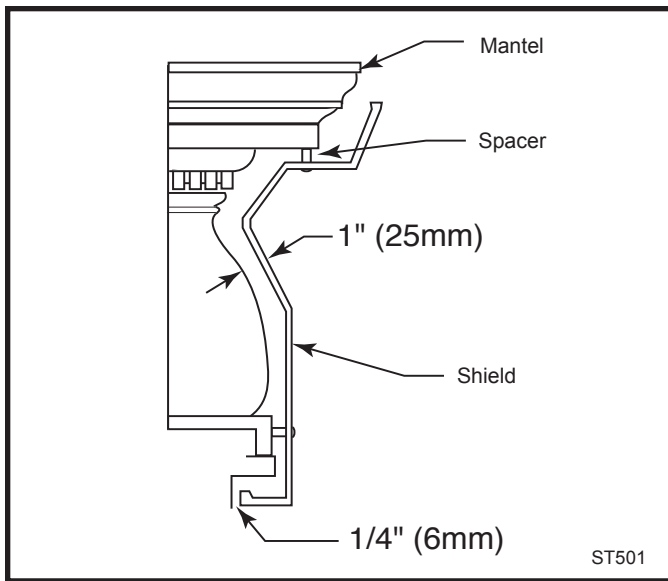

Fig. 14 A custom-formed mantel shield.

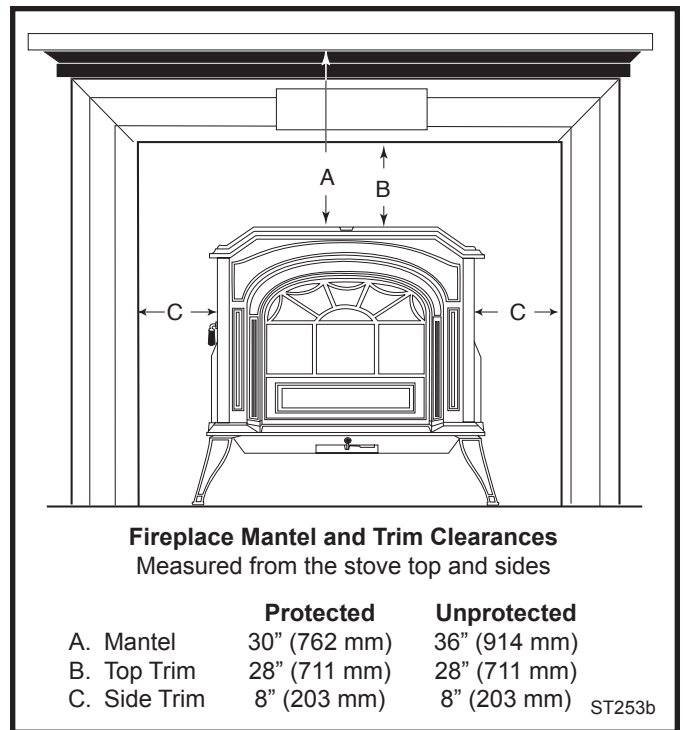

Fig. 15 Maintain clearances to combustible components of the mantelpiece.

## Resolute Acclaim Clearance Chart

<b>Stove Clearance</b>	<b>Unprotected Surface</b>			<b>Protected Surface</b>		
	<b>Parallel Installation</b>		<b>Corner Installation</b>	<b>Parallel Installation</b>		<b>Corner Installation</b>
	Side	Rear	Corner	Side	Rear	Corner
No heat shields	(A) 15" (380 mm)	(B) 24" (610 mm)	(C) 15" (380 mm)	(D) 8" (203 mm)	(E) 13" (330 mm)	(F) 8" (203 mm)
Top exit, rear heat shield only <sup>1</sup>	(G) 15" (380 mm)	(H) 24" (610 mm)	(I) 15" (380 mm)	(J) 8" (203 mm)	(K) 13" (330 mm)	(L) 8" (203 mm)
Rear exit, rear heat shield only	(M) 15" (38 mm)	(N) 10" (254 mm)	N/A	(O) 8" (203 mm)	(P) 7" (180 mm)	N/A
Top exit, rear h.s., single-wall connector, connector shields <sup>1,2</sup>	(Q) 15" (380 mm)	(R) 15" (380 mm)	(S) 15" (380 mm)	(T) 8" (203 mm)	(U) 9" (23 mm)	(V) 8" (203 mm)
Top exit, rear h.s., double-wall connector <sup>1,3</sup>	(Q) 15" (380 mm)	(R) 17" (432 mm)	(S) 15" (380 mm)	*		
<b>Chimney Connector Clearance</b>						
No Heat Shields	23" (580 mm)			12" (305 mm)		
Chimney connector heat shields <sup>2</sup>	14" (360 mm)			8" (203 mm)		
Double-wall connector <sup>3</sup>	16" (410 mm)			*		
<b>Front Clearance to Combustibles**</b>	All Installations 48" (1220 mm)					
<p>* Clearances with double-wall connectors and protected surfaces have not been tested for the Resolute Acclaim.</p> <p>** A distance of 48" must be maintained between the stove and moveable combustible items such as drying clothes, furniture, firewood, etc.</p> <p><sup>1</sup> When a rear heat shield is installed on a top exit stove, the shield insert must be attached to the shield so the area behind the flue collar on the stove is protected.</p> <p><sup>2</sup> Chimney connector heat shields must extend exactly 28" (710 mm) above the flue collar of the stove. No shielding can be used on the connector above 28" (710 mm). The unshielded chimney connector above the 28" (710 mm) point will be 14" (360mm) from an unprotected wall or 8" (203 mm) from a protected wall.</p> <p><sup>3</sup> In top exit installations, this clearance requires the use of the rear stove heat shield with the shield insert installed.</p>						

Unprotected Surfaces		Protected Surfaces	
Stove Installed Parallel to Wall	Stove in Corner	Stove Installed Parallel to Wall	Stove in Corner
<b>Top Exit, No Heat Shields</b>			
<b>Top Exit, Rear Heat Shield Only</b>			
<b>Rear Exit, Rear Heat Shield Only</b>			
	N/A		N/A
<b>Top Exit, Rear Heat Shield and single-wall connector w/shields, or double-wall connector</b>			

ST600

## Minimum Wall Shield Requirements for Common Installations

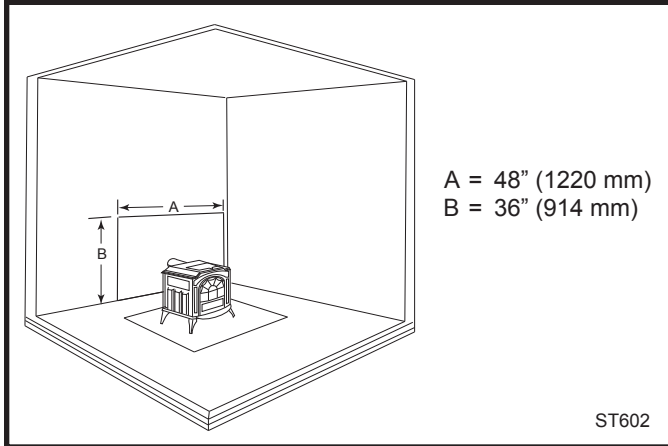

Fig. 16 A rear-exit stove with reduced rear wall clearance only.

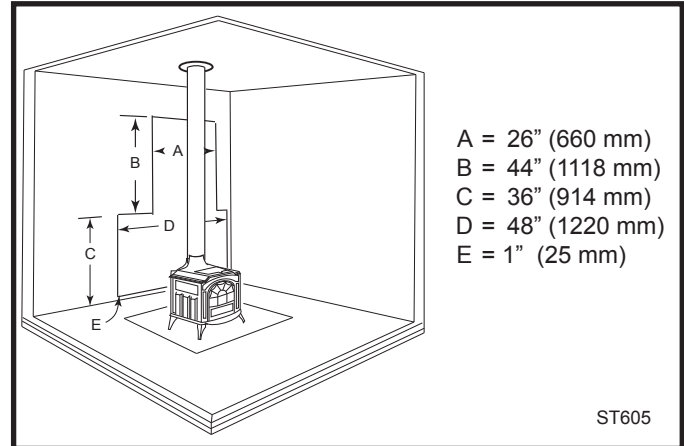

Fig. 19 A top-exit stove with a wall shield only (no pipe or stove heat shields). A 26" wide section of rear wall shield must be centered behind the connector.

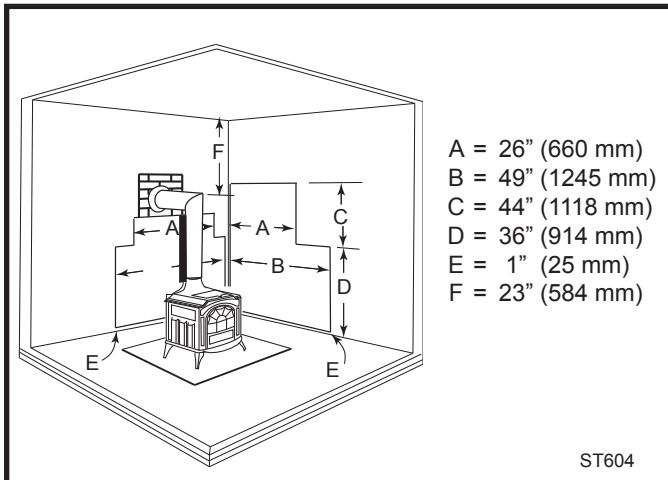

Fig. 17 A top-exit stove with 90° elbow and no stove or connector heat shields. Note clearance between chimney connector and ceiling.

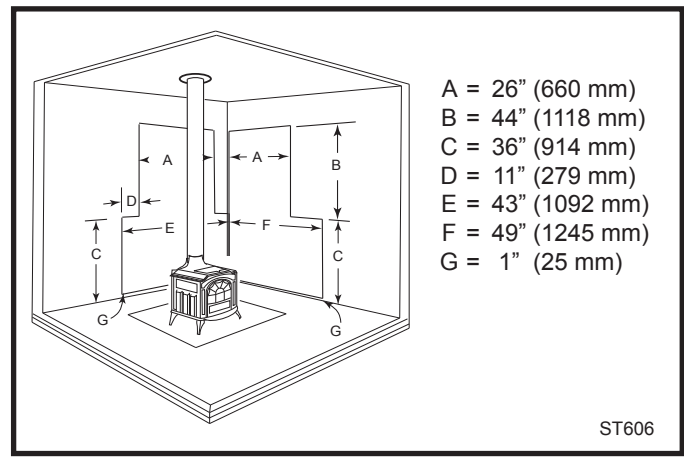

Fig. 20 A top-exit stove with reduced rear and side wall clearances. Note that rear wall shield must extend completely to corner.

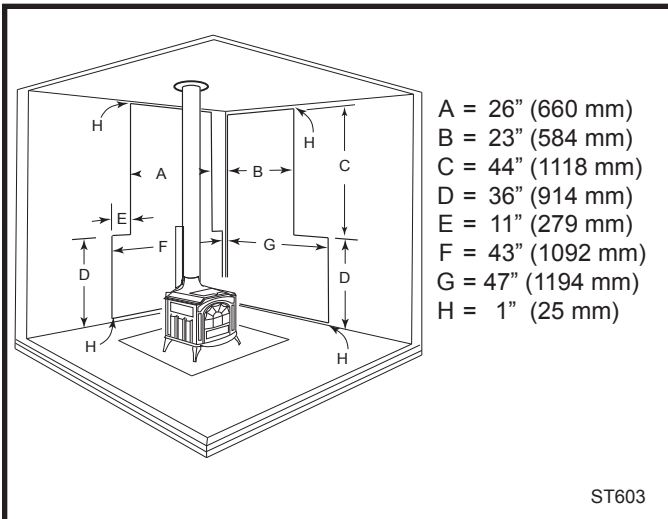

Fig. 18 A top exit stove with heat shields on both the stove and chimney connector. Reduced rear and side wall clearances. The chimney connector heat shield must be exactly 28". Note that rear and side wall shields meet at corner.

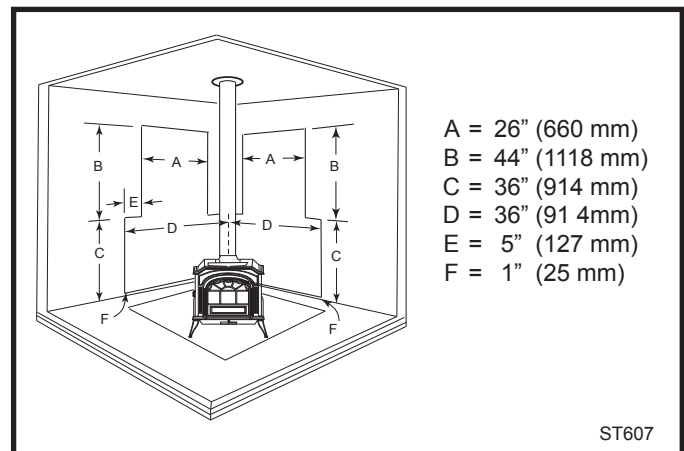

Fig. 21 A top-exit stove with reduced rear and side wall clearance. Wall shields must meet at corner.

## Distance from the Center of the Flue Collar to the Wall in Top-Exit Installations

The information on this page is helpful in planning stove placement for top-exiting installations, particularly those installations with chimneys that pass through the ceiling. However, this is not a clearance chart. Final stove clearances must adhere to the guidelines stated in the Clearance Chart on Page 12.

Resolute Acclaim: WITHOUT Stove and Chimney Connector Heat Shields					
Unprotected Surfaces			Protected Surfaces		
Parallel Installations		Corner Installations**	Parallel Installations		Corner Installations**
Side (A)	Rear (B)	Corner (C)	Side (D)	Rear (E)	Corner (F)
27½" (699 mm)	26" (660 mm)	25½" (648 mm)	20½" (521 mm)	15" (381 mm)	18½" (470 mm)

\* This distance, from the center of the flue collar to the front edge of the hearth, is the same for all installations on this page: 35" in the United States and 37" (940mm) in Canada.

Resolute Acclaim: WITH Stove and Chimney Connector Heat Shields					
Unprotected Surfaces			Protected Surfaces		
Parallel Installations		Corner Installations**	Parallel Installations		Corner Installations**
Side (A)	Rear (B)	Corner (C)	Side (D)	Rear (E)	Corner (F)
27½" (699 mm)	17" (432 mm)	25½" (648 mm)	20½" (521 mm)	11" (279 mm)	18½" (470 mm)

\*\*To locate center of flue collar for corner installation, add 10½" (270mm) to the clearance distance from stove corner to wall. Mark off the resulting distance from the corner along both walls. Next, measure the same distance from these two points out from the walls. These last two measurements will meet at a point representing the center of the flue collar. Refer to the diagrams above.

## Alcove Installations

Because of their restricted air flow and heat retention characteristics, specific construction requirements and special clearances apply to installations into alcoves. No stove or chimney connector heat shields are used in alcove installations. Bottom heat shield requirements remain the same as for other installations.

**ALCOVE INSTALLATION OF THE RESOLUTE ACCLAIM IS NOT PERMITTED IN CANADA.**

### Construction Requirements

Showing noncombustible ceiling framing and maximum and minimum permitted dimensions.

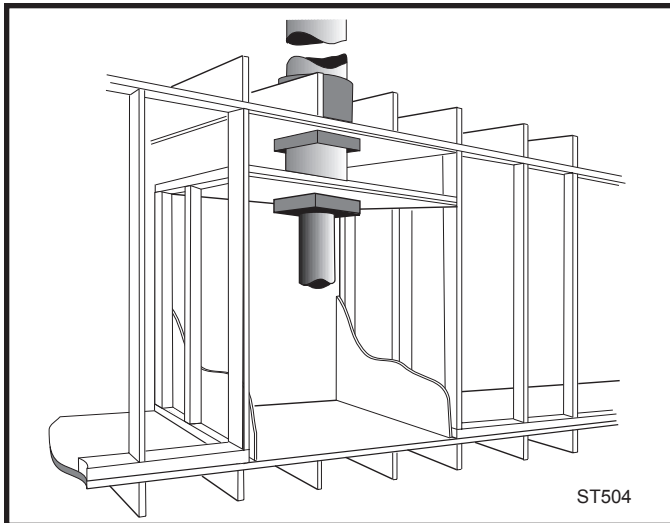

Fig. 22 Cutaway perspective of alcove installation.

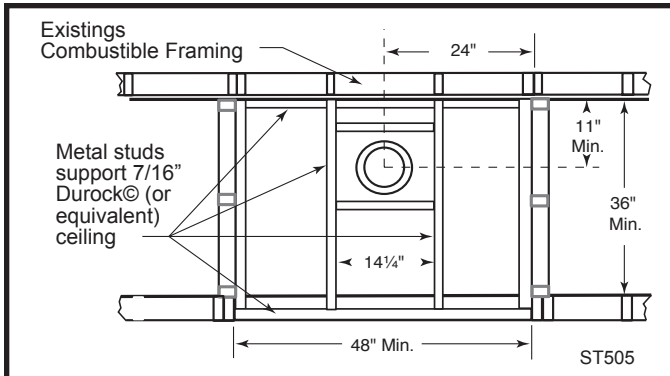

Fig. 23 Reflected ceiling plan.

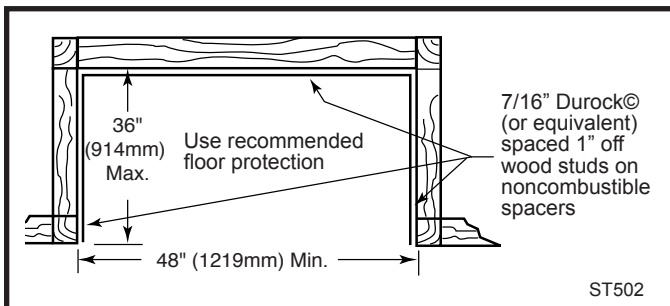

Fig. 24 Floor plan. Sheetrock on front face butts to Durock® (or equivalent) alcove lining.

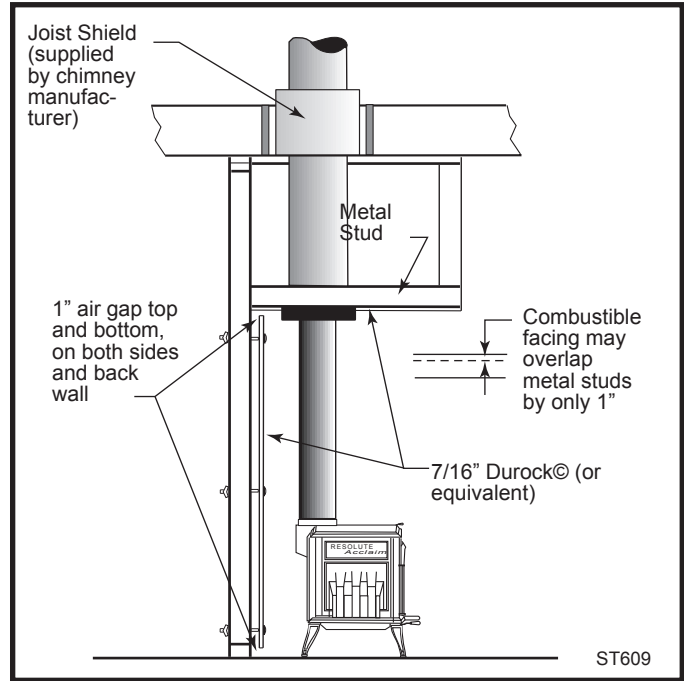

Fig. 25 Alcove side section.

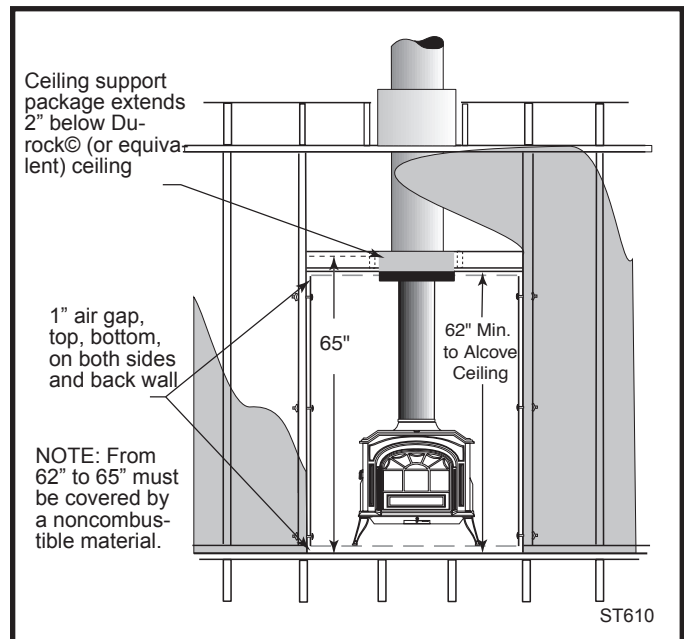

Fig. 26 Front section: 65" minimum clearance to combustibles on front face. Combustible facing may overlap metal studs by only 1". It should not extend below the height of the noncombustible ceiling.



## Operation

You will need the following tools to assemble the Acclaim:

- 9/16" open end wrench
- safety glasses & gloves
- flat head screwdriver
- power drill w/ 1/8" (3 mm) bit
- stub handle phillips screwdriver

### Unpack the Stove

1. Remove the shipping straps and plastic wrap.
2. Inspect the stove and contents for shipping damage or missing parts. Immediately notify your dealer of any damage. Do not install this stove if any damage is evident or any parts are missing.

#### Hardware Bag contents:

- Stove Legs, 4
- 3/8-16 x 1 1/4" hex head Leg Bolts with washers, 4
- Owner's Registration Card
- Touch-up Paint (Porcelain enamel stoves)

### Install Stove Legs

Remove and discard the four large slot-head screws from the stove bottom. Install the stove legs using the hex head bolts from the parts bag. (Fig. 26a) Use 3/8" washers with all four legs. Tighten the bolts firmly.

**CAUTION:** Overtightening can strip tapped threads.

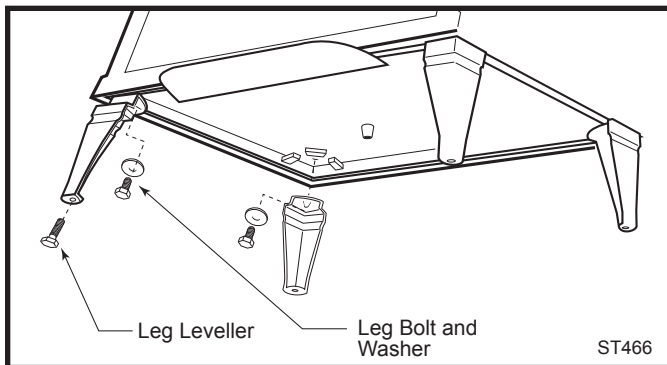

Fig. 26a Attach stove legs and leg levers.

### Stove Controls

#### Two Controls Operate the Stove

The **primary air control lever**, located beneath the ashlip, regulates how much heat the stove produces by controlling the amount of air received by the fire. The more air supplied, the hotter the fire. (Fig. 27)

With a travel range of about 6" (159 mm), the air control is closed when the lever is fully left. Maximum heat is produced when the lever is fully right. It may also be set anywhere between a "start-up" position and the high and low extremes to achieve a desired heat output. A directional arrow cast into the Acclaim's ash lip serves as a reminder of the correct "open" and "closed" positions.

The **damper handle** is located on the right side of the stove and controls air flow within the stove. (Fig. 27) The damper is open when the handle is toward the rear of the stove, and the combustion gases exit directly out the flue collar. When the handle is pulled forward and locked, the damper is closed, secondary combustion occurs, and the stove operates most efficiently.

The damper must be fully open or fully closed. There are no intermediate positions for the damper handle.

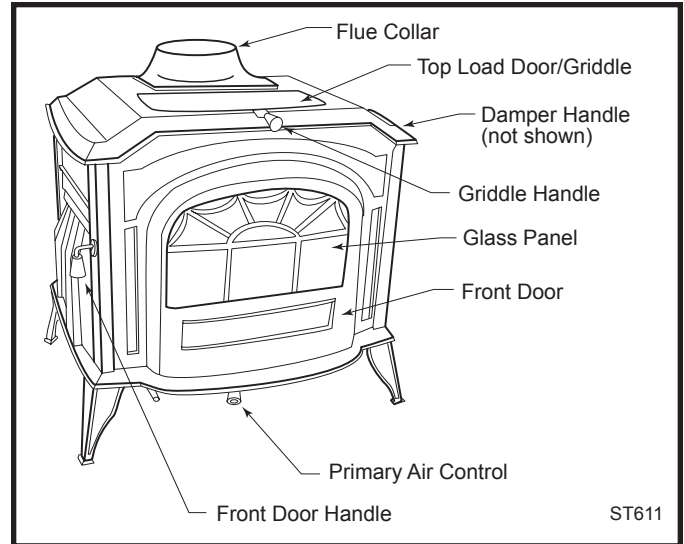

Fig. 27 The Resolute Acclaim controls are conveniently located and easy to use.

#### Two Ways to Add Logs and a Choice of Fire Views

Convenient top-loading of wood through the Acclaim's stovetop griddle supplements traditional fireplace-style loading through the front door.

The griddle simply lifts to open.

The front door employs a rotating cam and a door latch tab to secure it. The handle points down when the door is closed.

To open the front door, pull on the handle to release the cam. To close it, push the door until the latch engages. Double-check the latch by pushing lightly on the handle. When the latch is properly secured, the door will remain closed.

For clear fire viewing, the front door features a large, self-cleaning glass panel. The front door may be opened (or even removed) and the optional spark screen clipped in place for open-fire viewing as well.

## Removable Andirons For Greater Front-Loading Convenience

The **andirons** slip into pockets cast into the front of the bottom grate and can be removed when loading through the front door. (Most Acclaim owners, however, prefer the convenience of “smokeless” top loading.)

**IMPORTANT:** The andirons must be in place during operation. (Fig. 28) They not only help keep the **glass door panel** clear for fireviewing, but they assure proper placement of the fuel load for efficient clean-burning operation.

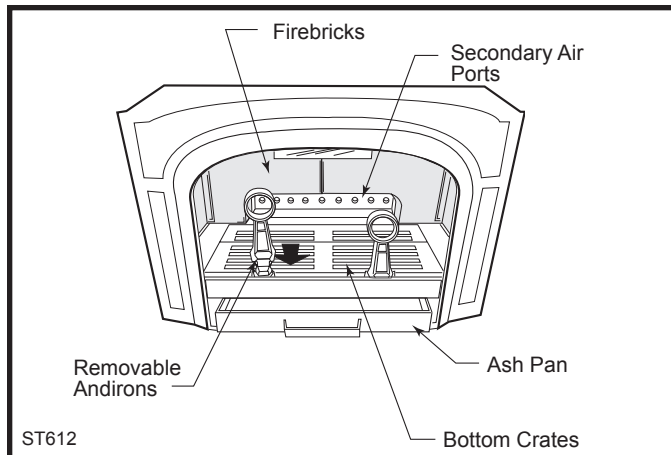

Fig. 28 A look inside the firebox of the Resolute Acclaim.

## Two Rules For Success

Burning wood is said to be more of an art than a science. You'll easily master the art if you start by using good, dry fuel, and understand how the stove's air supply system operates.

### Burn Only High-Quality Fuel

This heater is designed to burn natural wood only; do not burn fuels other than those for which this heater was designed.

Higher efficiencies and lower emissions generally result when burning air-dried, seasoned woods as compared to softwoods or freshly cut hardwoods. Avoid burning “green” wood that has not been properly seasoned. Also, do not use construction materials or trash as fuel; the chemicals, coatings and hardware that may be present can cause damage to the refractory material.

The best hardwood fuels include oak, maple, beech, ash, and hickory that has been split, stacked, and air-dried outside under cover for at least one year. Avoid burning cordwood that is over 2 years old as such fuel can contribute to short burn times, backpuffing and over-firing.

For areas that do not have a supply of hardwood, some of the better softwoods that are commonly burned include tamarack, yellow pine, white pine, Eastern red cedar, fir, and redwood. They too should be properly dried. The length

of the wood should be 16” (406 mm). Use of wood shorter than 16” may result in decreased burn times.

Wood should be stored under cover to maintain dryness. Even for short-term storage, keep wood a safe distance from the heater and keep it out of the areas around the heater used for refueling and ash removal.

## Use the Air Control Settings That Work Best for You

No single control setting will fit every situation. Each operation will differ depending on the quality of the fuel, the amount of heat desired, and how long you wish the fire to burn.

Control settings also depend on your particular installation's “draft,” or the force that moves air through the stove and up through the chimney. Draft is affected by such things as the length, type, and location of the chimney, local geography, nearby obstructions, and other factors.

Too much draft may cause excessive temperatures in the stove. On the other hand, too little draft can cause backpuffing into the room and/or insufficient heat.

How do you know if your draft is excessively high or low? Symptoms of too much draft include an uncontrollable burn or a part of the stove or chimney connector glowing red. Inadequate draft is indicated by smoke leaking into the room through the stove or chimney connector joints.

In some newer homes that are well-insulated and weather-tight, poor draft may result from insufficient air in the house. In such cases it may be necessary to duct combustion air to the stove directly from outside. In fact, in some areas, outside combustion air is required for stove installations in all new construction.

Your Resolute Acclaim is designed to easily incorporate outside combustion air with a Vermont Castings Outside Air Duct Adapter #3255 available from your local dealer.

When first using the stove, keep track of the air control settings. You will quickly find that a specific setting will give you a fixed amount of heat. It may take a week or two to determine the amount of heat and the length of burn you should expect from various settings.

Most installations do not require a large amount of combustion air, especially if adequate draft is available. Do not for any reason attempt to increase the firing rate of your heater by altering the air control adjustment range outlined in these directions.

Use the following air control settings as a starting point to determine the best settings for your needs.

## Primary Air Settings

Air Setting	Air Control Position
CLOSED	Fully Left
LOW	Approximately 1" (25 mm) to the right of CLOSED.
HIGH	Approximately 3" (80 mm) to the right of CLOSED, where the lever hits the stop.
START-UP	Fully Right

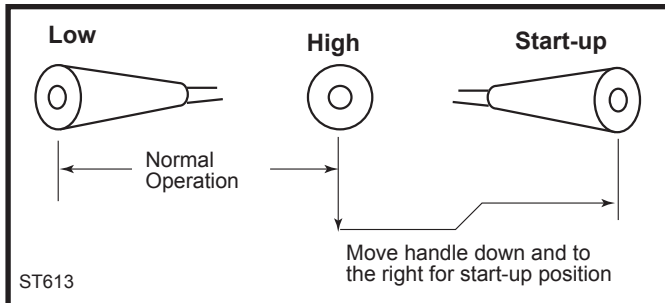

**Fig. 29** Variable settings for the primary air control between the open and closed positions provide a range of heat output.

## How to Build and Sustain a Wood Fire

You can load wood into your Resolute Acclaim through either the top or front loading door. Front-loading is useful for kindling a new fire, but we recommend top loading as the most convenient way of regularly adding several logs at a time.

Your Resolute Acclaim may be operated with the front door open for fireplace-style viewing as well as closed. Always be certain the stove damper is open when the door is open and always use the optional firescreen for fire viewing.

## Starting and Maintaining A Wood Fire

A new stove needs to be "broken in." Since cast iron plates expand and contract in response to temperature change, let them adjust gradually to heating and cooling. To properly break in your stove, follow Steps 1-3 below only for your first three or four fires. After that, you may go on to Step 4 and normal operation of the stove.

The stove paint and cement will emit a slight odor during the first few fires. We suggest that you provide extra ventilation near the stove by partially opening a door or window when the odor is present.

**WARNING: Operate only with doors fully open or doors fully closed. If doors are left partly open, gas and flame may be drawn out of the fireplace stove opening, creating risks of both fire and smoke.**

1. Open the stove damper, and open the primary air control fully to the Start-up position.
2. Lay some crumpled newspapers in the stove. Place six or eight pieces of dry kindling split to a finger-width

size on the paper, and on the kindling lay two or three larger sticks of split dry wood approximately 1-2" (25-50 mm).

**Do not use chemicals or fluids to start the fire. Do not burn garbage or flammable fluids such as gasoline, naphtha or engine oil.** Also, never use gasoline-type lantern fuel, kerosene, charcoal lighter fluid, or similar liquids to start or "freshen up" a fire in this heater. Keep all such liquids well away from the heater while it is in use.

3. Light the newspaper and close the door. The fire soon will be well-established and you may gradually build it up by adding a few sticks at a time of a progressively larger size.

For your initial three or four break-in fires, let the fire burn brightly for a short time, then let it die out.

**NOTE:** Some chimneys need to be "primed," or warmed up, before they will draw sufficiently to start a fire. To correct this situation, roll a couple of pieces of newspaper, place them on top of the kindling and toward the back of the stove, light them, and close the doors. This should get the smoke moving in the right direction.

Once the draft is established, open the front door and light the rest of the fuel from the bottom. Do not light the main bed of fuel until the chimney begins drawing, and repeat the procedure as often as necessary if the initial attempt is unsuccessful.

**NOTE: CONTINUOUS OPERATION WITH THE AIR CONTROL IN THE START-UP (FULLY OPEN) POSITION MAY SHORTEN THE LIFE OF THE INTERNAL CASTINGS.**

4. Once the fire is burning steadily, continue adding fuel until a thick ember bed has been established on the grate. The bed must be about 4" (102 mm) deep at the back of the grate and about 1" (25 mm) deep at the front, and should cover the throat opening into the secondary combustion chamber that is located in the center of the lower fireback.

If your wood is well-seasoned, the damper may be closed when the griddle temperature reaches 500° F (260°C). Depending on the type of wood being burned and its moisture content, it may take several hours to establish and then maintain the ember base that is required for high-efficiency operation.

5. Once the ember bed is formed, prepare the stove for high-efficiency operation. Load it with fuel, first with smaller splits of wood and then larger ones.

Close the damper and set the primary air control lever to the "HIGH" position. Operate the stove for 15 - 20 minutes at this maximum air setting to guarantee the new load of fuel has fully ignited. Once the fuel is burning steadily, you may adjust the primary air supply to provide the desired heat output.

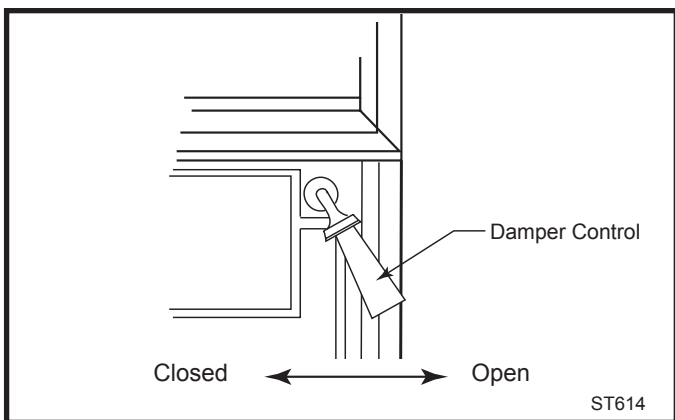

**Fig. 30** With the damper closed, secondary combustion takes place and the Acclaim operates most efficiently.

You'll soon find this stove is **HOT WHILE IN OPERATION! KEEP CHILDREN, CLOTHING, AND FURNITURE AWAY. CONTACT MAY CAUSE SKIN BURNS.**

**DO NOT OVERFIRE THIS HEATER.** Overfiring can result in permanent damage to the stove. If an exterior part of the stove or the chimney connector glows, you are overfiring.

### Reloading and Reviving a Wood Fire

Reload your stove while it is still hot and there are plenty of embers to re-ignite the fire quickly. Include some smaller pieces of wood in the new load of fuel to help the stove regain high temperatures quickly.

Follow this procedure when you reload your stove:

- Open the damper and move the primary air lever to the "HIGH" position.
- Open the front door and check the ash level on the grates and in the ash pan. Clear excess ash from the grates, particularly at the rear area. Level the ember bed. Empty the ash pan if necessary.
- Replace the ash pan and close the front door.
- Load wood, smaller pieces first, and close the loading door.

**NOTE:** If the ember bed has burned down to the extent the fire cannot be revived easily, it may be necessary to set the air control to the "Start-up" position until the fire has been re-established.

- Allow the stove to regain its "thermal momentum" before closing the damper. This may take 15 - 20 minutes, and will be confirmed by a temperature on the griddle of at least 500°F (260°C).
- Close the damper, and set the primary air lever for the desired heat output.

**NOTE:** If the remaining charcoal bed is relatively thick and if your fuel is well seasoned, it is possible to add fresh fuel (smaller pieces first), close the door and damper, and reset the primary air within 5 minutes.

### A Surface Thermometer is a Guide to Performance

Until you are familiar with how your stove works, monitor the griddle surface temperature frequently. Use these temperature ranges as general indicators of heat output:

Low to medium	350-500°F (177-260°C)
Medium	500-600°F (260-318°C)
High	600-750°F (318-399°C)

Continuous operation at griddle temperatures higher than 750°F (399°C) may damage the cast iron parts or the porcelain enamel finish of your Resolute Acclaim.

A surface thermometer can also tell you when to adjust the controls and when to refuel the stove. (Fig. 31)

During start-up and after re-loading, for example, a thermometer reading of at least 500°F (260°C) signals the stove is hot enough to close the damper and shift into the high-efficiency mode.

Readings lower than 350°F (177°C) announce the stove needs loading or it is time to increase the air supply for a higher burn rate.

At the other extreme, a temperature over 750°F (399°C) is a warning to slow the burn rate.

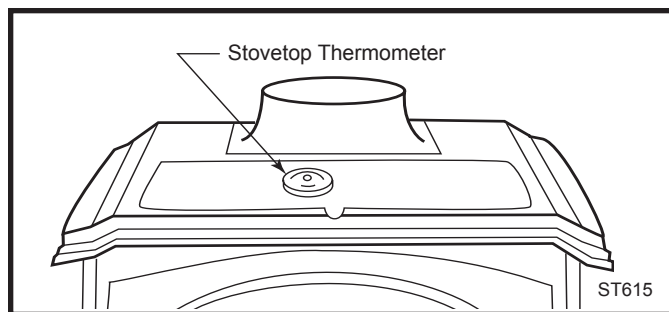

**Fig. 31** A thermometer gives temperature readings that help you to operate your stove safely and effectively.

### Rules for Open Fire Viewing

**WARNING: FOR SAFETY AND GREATEST EFFICIENCY, OPERATE YOUR STOVE ONLY WITH ALL DOORS/GRIDDLES FULLY CLOSED. THE TEST STANDARD FOR YOUR STOVE WHEN IT IS OPERATED IN THIS MODE IS UL 1482.**

**YOUR STOVE MAY BE USED AS A FIREPLACE WITH THE FRONT DOOR OPEN OR REMOVED ONLY WHEN THE SPARK SCREEN IS PLACED CORRECTLY IN THE OPENING TO PROTECT AGAINST THE POSSIBILITY OF SPARKS AND EMBERS LEAVING YOUR STOVE. THE TEST STANDARD FOR YOUR STOVE WHEN IT IS OPERATED IN THIS MODE IS UL 737.**

**USE ONLY THE RESOLUTE ACCLAIM SPARK SCREEN, PART #0133, WITH YOUR ACCLAIM .**

**RESOLUTE ACCLAIM SPARK SCREENS ARE AVAILABLE FROM YOUR VERMONT CASTINGS' AUTHORIZED DEALER.**

The damper must be open as well whenever you operate the Resolute Acclaim in the open-fire mode. This will prevent smoke and combustion gases from entering the room.

The spark screen fits inside the arch of the inner stove front and is held in place by a top bail and two side clips. (Fig. 32) To insert the screen, place the top bail between the inner front and the air manifold. Push with an even pressure on the sides until the clips snap into place.

The front door may be left on or taken off. To remove it, open it and retract the spring-loaded upper hinge pin. Tilt the door slightly and lift it off the lower hinge pin.

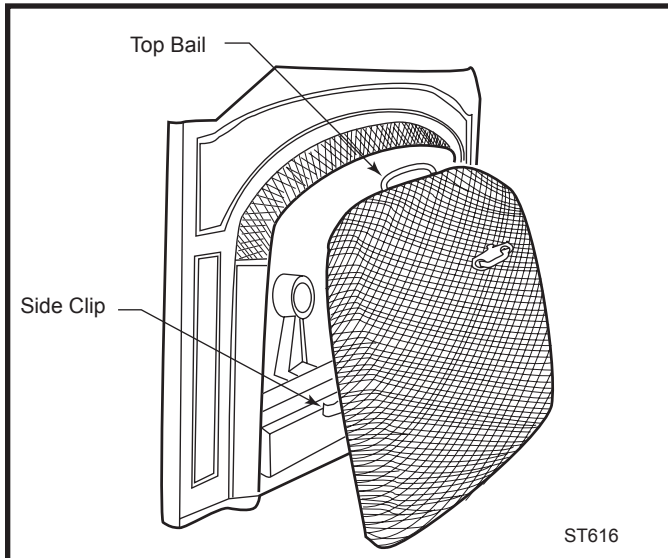

**Fig. 32** Angle the screen to seat the top first, then push the bottom straight in until the clips snap into place.

### Clear the Ash Frequently

The slanted grate is designed to shape the charcoal bed to promote high temperatures near the entrance to the secondary combustion chamber. The grates must be kept free of heavy ash accumulation. Clear ash manually every six to eight hours of operation or before you reload.

To clear the ash, “hoe” the ash and charcoal forward with a stove shovel or similar fireplace tool so they drop through the grate. **CAUTION:** Do not put any tool up into the secondary combustion chamber or you will risk damaging the refractory package.

### Remove and Store Ash Safely

Check the ash pan before reloading the stove. If the ash is close to the top, empty the pan. Before replacing the ash pan, clear away any ash that has spilled over the sides and back of the pan.

When burning wood, empty the ash drawer regularly, typically every one to three days. The frequency will vary depending on how hot you run your stove: the hotter the fire, the more wood you burn, and the faster ash will accumulate.

The ash pan is located in the ash drop chamber with a handle attached to the front and one to the rear. Always use stove gloves when handling the ash pan. Keep it level, and carry it outside for disposal. Empty the ash into your ash disposal container. When you are finished, slide the pan back into the stove.

Ash may contain hot coals and must be treated with extreme care. It should be removed frequently and placed outdoors in a metal container with a tight-fitting lid. The closed container of ash should be placed on a noncombustible floor or on the ground, well away from all combustible materials, pending final disposal.

If the ash is disposed of by burial in soil or otherwise locally dispersed, it should be retained in the closed container until all cinders have thoroughly cooled. Wood ash may be used as a garden fertilizer.

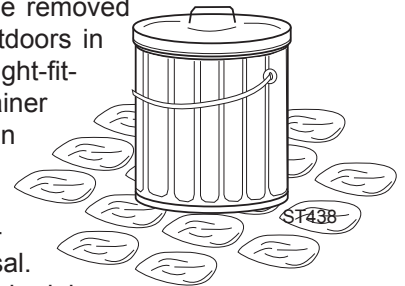

**CAUTION: NEVER USE A VACUUM CLEANER TO REMOVE ASH FROM THE STOVE; ALWAYS REMOVE AND DISPOSE OF THE ASHES PROPERLY.**

## Draft Management

A stove is part of a system, which includes the chimney, the operator, the fuel, and the home. The other parts of the system will affect how well the stove works. When there is a good match between all the parts, the system works well.

Wood stove operation depends on natural (unforced) draft. Natural draft occurs when the smoke is hotter (and therefore lighter) than the outdoor air at the top of the chimney. The bigger the temperature difference, the stronger the draft. As the smoke rises from the chimney it provides suction or 'draw' that pulls air into the stove for combustion. A slow, lazy fire with the stove's air inlet fully open indicates a weak draft. A brisk fire, supported only by air entering the stove through the normal inlet, indicates a good draft. The stove's air inlet is passive; it regulates how much air can enter the stove, but it doesn't move air into it.

Depending on the features of your installation - steel or masonry chimney, inside or outside the house, matched to the stove's outlet or oversized - your system may warm up quickly, or it may take a while to warm up and operate well. With an 'airtight' stove, one which restricts the amount of air getting into the firebox, the chimney must keep the smoke warm all the way to the outdoors. Some chimneys do this better than others. Here's a list of features and their effects.

### Masonry Chimney

Masonry is a traditional material for chimneys, but it can perform poorly when it serves an 'airtight' stove. Masonry is a very effective 'heat sink' - it absorbs a lot of heat. It can cool the smoke enough to diminish draft. The bigger the chimney, the longer it takes to warm up. It's often very difficult to warm up an outdoor masonry chimney, especially an oversized one, and keep it warm enough to maintain adequate draft.

### Steel Chimney

Most factory-made steel chimneys have a layer of insulation around the inner flue. This insulation keeps the smoke warm. The insulation is less dense than masonry, so the inner steel liner warms up more quickly than a masonry chimney. Steel doesn't have the good looks of masonry, but it performs much better.

### Indoor/Outdoor Location

Because the chimney must keep the smoke warm, it's best to locate it inside the house. This uses the house as insulation for the flue and allows a little heat release into the home. An indoor chimney won't lose its heat to the outdoors, so it takes less heat from the stove to get it warm and keep it warm.

### Flue sizing

The inside size of a chimney for an 'airtight' stove should match the size of the stove's flue outlet. When a chimney serves an airtight, more is not better; in fact, it can be a disadvantage. Hot gases cool off through expansion; if we vent a stove with a six-inch flue collar (28 square inch area) into a 10 x 10" flue, the gases expand to over three times their original size. This cools the gases, which weakens draft strength. If an oversized flue is also outside the house, the heat it absorbs gets transferred to the outdoor air and the flue usually stays cool.

It's common for a masonry flue, especially one built for a fireplace, to be oversized for an airtight stove. It can take quite a while to warm up such a flue, and the results can be disappointing. The best solution to an oversized flue is an insulated steel chimney liner, the same diameter as the stove or insert's flue outlet; the liner keeps the smoke at its original volume, and the result is a stronger draft. An uninsulated liner is a second choice - the liner keeps the smoke restricted to its original size, but the smoke still must warm up the air around the liner. This makes the warm-up process take longer.

### Pipe & Chimney Layout

Every turn the smoke must take in its travel from the stove to the chimney top will slow it down. The ideal pipe and chimney layout is straight up from the stove, to a completely straight chimney. If you're starting from scratch, use this layout if possible. If the stovepipe must elbow to enter a chimney, locate the thimble about midway between the stove top and the ceiling. This achieves several goals: it lets the smoke speed up before it must turn, it leaves some pipe in the room for heat transfer, and it gives you long-term flexibility for installing a taller stove without relocating the thimble.

There should be no more than eight feet of single-wall stove pipe between the stove and a chimney; longer runs can cool the smoke enough to cause draft and creosote problems. Use double-wall stove pipe for long runs.

### Single Venting

Each 'airtight' stove requires its own flue. If an airtight stove is vented to a flue that also serves an open fireplace, or a leakier stove, it's easier for the chimney draft to pull air in through those channels than it is to pull air through the airtight, and performance suffers. Imagine a vacuum cleaner with a hole in the hose to see the effect here. In some cases the other appliance can even cause a negative draft through the airtight, and result in a dangerous draft reversal.

## Creosote

Creosote is a by-product of slow wood-burning. It's an organic tar that can condense in the flue if it's dense in the smoke, and slow-moving, and cools off to less than 290°F. Condensed creosote is volatile, and can generate chimney fires if it gets hot enough. All the features that affect chimney draft also affect creosote condensation - so use whatever combination of installation features and operational steps will encourage good draft and minimize creosote production.

Because letting the smoke cool off and slow down is one of the keys to creosote production, it makes sense to line a chimney to match the stove's outlet size, for safety reasons as well as performance. Canadian law requires a matching liner to serve any stove or insert vented through a fireplace chimney; in the US, the National Fire Protection Association recommends one if the flue is more than three times bigger (in square area) than the outlet on the stove or insert. Some localities enforce the NFPA guidelines as part of their building codes.

## Fuel

Even the best stove installation will not perform well with poor fuel. The best fuel is hardwood that has air-dried 12-18 months. Softwood burns, but not as long as hardwood. Fairly 'green' wood has a good amount of moisture in it; it will burn, but some of the heat potential is used to drive the remaining moisture off the wood. This reduces the amount that reaches your home and can contribute to a creosote problem. There are moisture meters available for firewood; you can also judge your wood by its appearance and weight. If you get it green, lift a piece and get a sense of its weight; it can lose a third or more of its weight as it dries. Also look at the ends of a log; as it dries it shrinks and often cracks. The more weathered and cracked a piece is, the drier it is.

Dry wood burns readily with a good chimney draft. But with modern stoves, especially catalytic ones, the wood can be too dry. While extra-dry wood has little creosote in it, the remainder can 'gas out' from the wood quickly and densely enough to overload the catalytic burner. If you hear a rumbling or roaring noise, like a propane torch, from the stove, that is a sign that the catalyst is seriously overfiring. The catalyst is a platinum film on a ceramic base; the metal can get to higher temperatures than the ceramic can take, and overfiring the catalyst can break it. Dry wood can also burn out faster than you want. If your dry wood burns out too quickly or overloads the catalyst you can mix in greener wood to slow the fire down.

## Back-puffing

Back-puffing results when the fire produces volatile gases faster than the chimney draft pulls them out of the firebox. The gases back up in the firebox till they're dense enough and hot enough to ignite. If your stove back-puffs, you should open up the damper to let the smoke rise to the flue more quickly, let more air into the firebox, and avoid big loads of firewood. Run your stove with enough primary air so that you always see lively, dancing flames in the firebox; a lazy, smoky fire is inefficient and can contribute to creosote buildup in the chimney.

## Draft Testing

An easy way to test your chimney draft is to close the stove's damper, wait a few minutes to let the airflow stabilize, then see whether you can vary the strength of the fire by swinging the air control open and closed. Results are not always instant; you may need to wait a few minutes for a change in the air control setting to have an effect on the fire. If there's no change, then the draft isn't strong enough yet to let you close the damper, and you'll need to open it for a while longer and manage the fire with the air inlet until the draft strengthens. If you keep track of your burning habits and relate them to their effects on the stove's operation, you'll be rewarded with good performance and a safe system.

## Negative Pressure

Good draft also depends on a supply of air to the stove; a chimney can't pull in more air than is available to it. Sluggish draft results when a house is tight enough to prevent the ready flow of air to the stove, or by competition between the stove and other equipment that sends indoor air outside - especially power-driven equipment like range hoods, clothes dryers, etc. If the chimney draws well with all other equipment turned off (or sealed, in the case of fireplaces and/or other stoves), then you simply need to be careful with timing the use of the other equipment. If you need to crack a nearby window or door to enable the chimney to draw well, that's a sign that you should install an outside-air intake to bring combustion air directly to the stove. Vermont Castings Majestic Products Company dealers carry adapters to attach to the stove to connect an air duct for outdoor combustion air.

## Conclusion

Wood-burning is an art rather than a science. Once the stove and chimney system are in place, the stove user can only vary technique, mostly your timing, to achieve good results. If you keep track of your burning habits and relate them to their effects on the stove's operation, you'll be rewarded with good performance and a safe system.

## Maintenance

### Keep Your Stove Looking New and Working Its Best

#### Care of the Cast Iron Surface

An occasional dusting with a dry rag will keep the painted cast iron of your Resolute Acclaim looking new. A damp cloth may be used as well, but only when the stove is cool. Make sure no water remains on the stove surface.

If the paint needs retouching, allow the stove to cool completely. Wire-brush areas needing to be painted. Remove non-painted components such as air controls or cover them with masking tape. Touch up the stove with high temperature stove paint available from your local dealer. Apply the paint sparingly. Two light coats are better than one heavy one.

#### Care of the Porcelain Enamel Surface

Use a dry rag or a soft brush. Do not use water or other liquids. Fingerprints usually can be buffed off with a dry, soft rag. If marks remain, allow the stove to cool completely, then buff with a damp, soft rag. Dry completely before starting a fire so that water drops or wet streaks will not leave marks. Never use abrasives or harsh chemical cleaners on the porcelain enamel finish.

To remove stains or spills from porcelain enamel, first make sure that the stove is completely cool. Use only a kitchen appliance cleaner or polish recommended for enamel surfaces. Apply sparingly with a soft rag and buff away all traces of the cleaner.

#### Cleaning the Glass

Most of the carbon deposits on the glass will burn off regularly during hot fires. If you wish to clean the glass more thoroughly, follow this procedure:

- Let the stove and glass cool completely.
- Wash the glass with warm water, and a soft paper towel or rag.
- Rinse and dry thoroughly.
- Never use abrasives, ashes, or harsh chemicals to clean your Resolute Acclaim glass.

For stubborn deposits, use a ceramic glass cleaner available from your Vermont Castings' Authorized Dealer. Do not allow the cleaner to touch brass ornaments or porcelain finish.

#### Clean the Exhaust Channels

The firebricks and sealing plates should be removed and the exhaust area on either side of the secondary combustion package should be vacuumed carefully at least once a year, or after every 60 days of sustained burning. Follow these steps:

- Remove the ashpan, the griddle and the andirons.
- Remove the left and right side firebrick by lifting them approximately 1/2" and swinging the front edge in toward the firebox center. Inserting a flat screwdriver blade underneath the brick and lifting will make the removal easier.

**WARNING: Handle firebrick with care. Protruding steel reinforcement wires could cause injury. Rough handling could break firebricks.**

- Remove the two rear firebricks by leaning them forward, removing the retainer clip and lifting them out through the griddle opening.
- Remove both grate sections.
- Remove the sealing plates by removing the 7/16" hex head bolts and pulling the plate forward.

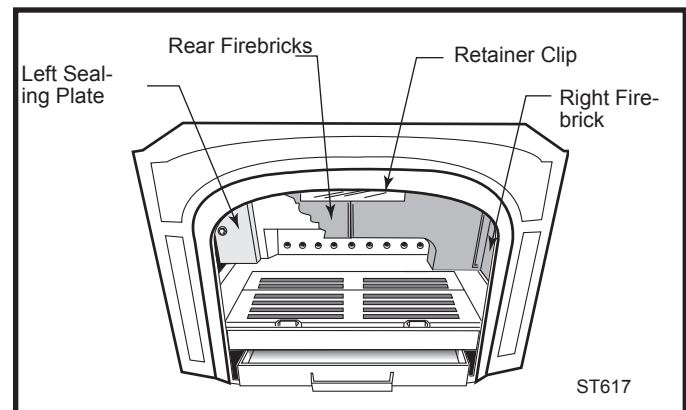

**Fig. 33** Remove left and right sealing plates.

- Vacuum debris from both sides of the exposed refractory combustion package, being careful not to impact the fragile refractory material.
- Check the gasket which the sealing plates seal against. Replace if necessary following the directions for gasket replacement that follow.
- Replace the grate sections.
- Replace the sealing plates, rear firebricks, retainer clip and the side firebricks in that order.



## Repair Air Leaks to Prevent Overheating and Excessive Fuel Consumption

### Adjust the Door Latch

The door gasket will compress after use. To restore a tight seal, adjust the tension on the latch:

- Remove the Allen head button screw that attaches the door latch tab to the stove front. (Fig. 34)
- Remove one of the washers that separates the tab from the front (save it for future use.)
- Replace the remaining washers and the door latch tab.
- Remove another washer if necessary.
- Test the seal by closing the door on a slip of paper and attempting to pull the paper free. If the paper is freed without tearing, the gasket isn't snug enough at that spot.

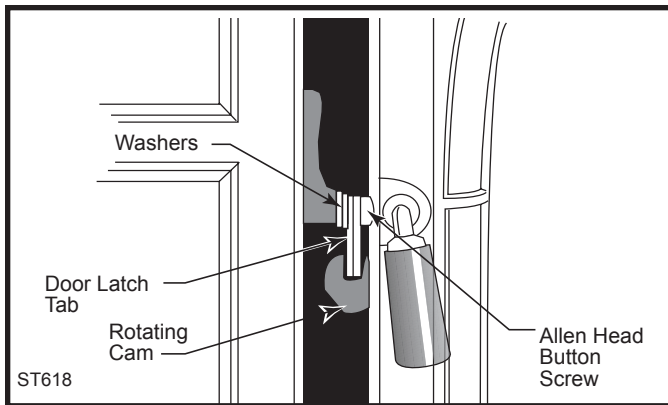

**Fig. 34** The front door seal can be adjusted simply by adding or removing washers.

If the paper indicates a low spot in a specific area, try “adjusting” the gasket in that area. Pack more cement or a smaller diameter gasket into the channel beneath the gasket so that the main gasket is raised and makes contact with the door frame. This procedure should solve the problem. If it doesn't, replace the gasket following these steps:

- Wearing safety goggles and a dust mask, remove the original gasket by grasping an end and pulling firmly.
- Use a wire brush or the tip of a screwdriver to clean the channel of any remaining cement or bits of gasket.
- Apply a thin bead of stove cement in the newly-cleaned groove.
- Pack the gasket into the groove. Wait until you are a couple inches from the end before you cut it.
- Test the gasket by closing the door on a slip of paper such as described above. Adjust the gasket in any areas where an inadequate seal is evident.

### Adjust the Door

Although it is unlikely that adjusting it will be necessary, the height of the Resolute Acclaim's front load door is adjustable. The lower door hinge pin has a shoulder that lifts or lowers the door as you screw the pin up or down.

### Repair Missing Cement in Seams

The cement in the stove seams may deteriorate over time and fall out in places. Just as with the stove doors, it is necessary to keep the seam seals in good condition. Spot-fix with furnace cement (available from your local dealer) any areas where the cement seal is visibly deteriorated. Allow 24 hours for the new cement to dry.

### Adjust the Damper as Needed

The tension of the Resolute Acclaim's torsion bar is adjustable to compensate for compression of the gasket that seals the damper to the damper frame. To adjust the damper:

- Loosen the lock nut on the set screw in the center of the damper. (Fig. 35)
- Turn the set screw approximately one half-turn clockwise.
- Re-tighten the lock nut and test the damper mechanism.

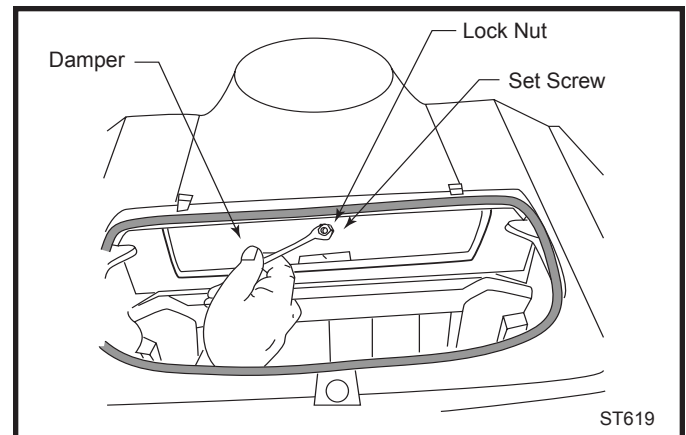

**Fig. 35** When the damper's gasket becomes compressed after prolonged use, the damper should be adjusted to regain a tight seal.

### Avoid Damaging the Glass

Do not abuse the glass in the front door by slamming the door shut or by striking the glass with a piece of wood, and never operate your stove if it has damaged or broken glass. If you need to replace the glass, use only glass provided by Vermont Castings Group.

## Replace Broken Glass Immediately

Do not operate the Resolute Acclaim if the glass is damaged. Use the following procedure for glass replacement. **NOTE:** Replace glass with Vermont Castings Group replacement glass only, available from your local dealer.

- Open the door and carefully remove the glass by removing the two (2) clips (one per side) that hold the glass panel against the gasket in the arched door opening. Each clip is held in place with two (2) Phillips truss-head machine screws. (Fig. 36)

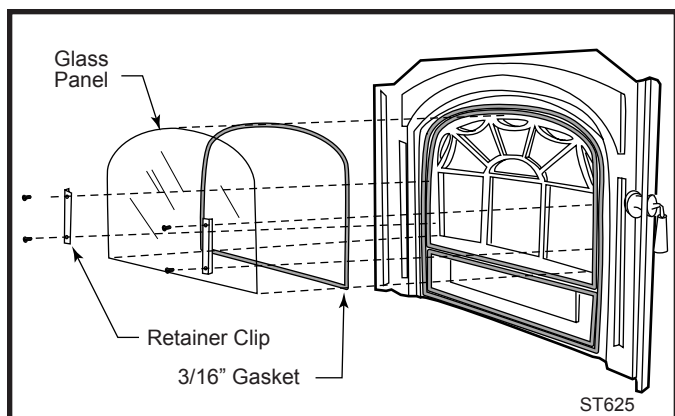

Fig. 36 Glass replacement.

- Examine the gasket that seals the glass to the door frame. Replace if necessary with gasket obtained from your local Vermont Castings' Authorized Dealer.
- The glass used in your Resolute Acclaim is specially coated on one side with a heat reflecting material. Examine the replacement glass panel, and notice the markings along the edge.
- Center the replacement glass panel in the arched door opening, with the marked side of the glass panel facing the gasket. There should be a gap to allow for expansion and contraction between the edge of the glass panel and the cast iron.
- Replace the two retainer clips and fasten with the previously removed screws. Tighten the screws slowly and evenly; do not overtighten.

## How to Replace Gaskets

The Resolute Acclaim uses rope-type fiberglass gaskets to make a tight seal between some parts. With use, particularly on those parts that move, gaskets can become brittle and compressed and can begin to lose their effectiveness. These will need periodic replacement.

All of the gaskets used are made of fiberglass. The three sizes of replaceable gasket are listed below, along with their application.

## Resolute Acclaim Gaskets on Moving Parts

Gasket Size...	...And The Parts It Seals
3/16"	The glass to the load door frame
5/16" wire mesh	The griddle to the stove top
1/2"	The arch and bottom edge of the inner front stove panel to the front

load door  
 1/2" load door      The front of the grate to the front

Should you need to change a replaceable gasket, wait until the fire is out and the stove has cooled. Be sure to follow the standard safety procedure for working with dusty materials: wear safety goggles and a dust mask. The procedure for replacing gaskets is the same, regardless of the gasket location. Four easy steps are involved:

1. Remove the existing gasket by grasping an end and pulling firmly. (Fig. 37)
2. Use a wire brush or the tip of a screwdriver to clean the channel of any remaining cement or bits of gasket. Use a cold chisel for stubborn deposits.

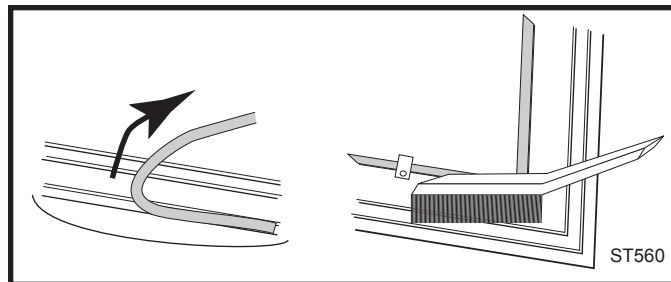

Fig. 37 Remove gasket, then clean channel with wire brush.

3. Apply a thin (1/8") unbroken bead of stove cement to the newly-cleaned groove.
4. Starting at one end, pack a new gasket into the groove. Where the two ends of the gasket meet, ensure a good joint before trimming any excess. Do not overlap or leave ragged edges. (Fig. 38)

Other gaskets form seals between non-moving parts, but these are not subject to the same wear and deterioration as gaskets on moving parts. It is unlikely that you will ever need to replace these gaskets unless the involved parts are disassembled and then put back together. In any event, this is a job that should be done only by qualified service personnel.

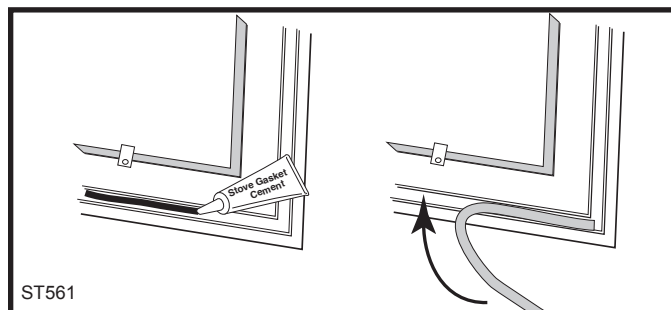

Fig. 38 Lay a bead of gasket cement then press gasket in place.

### Gaskets on Resolute Acclaim Stationary Parts

- 5/16" Between the flue collar and flue collar extension and the stove's top and back:
- 5/16" The seal between the upper fireback corners and the lower fireback:
- 5/16" The seal between the underside of the top plate and the upper edge of the upper fireback
- 5/16" The damper plate to the reverse side of upper fireback
- 5/16" The seal between the sealing plates and the vertical ribs of the stove back

**NOTE:** When replacing this last gasket after removing the upper fireback, place two (2) cap screws into the upper fireback mounting holes before you cement the channels and replace the gasket. The new gasket will run inside the cap screws. Remove the screws after the gasket cement dries.

### Replacing the Door Gaskets

- Lift off the door as described previously. Lay it face down on a padded surface.
- Follow steps 1-4 on gasket replacement as described previously.

### Replacing the Griddle Gasket

- To replace either the damper or the griddle gasket, follow Steps 1-4 on replacing gaskets described previously.

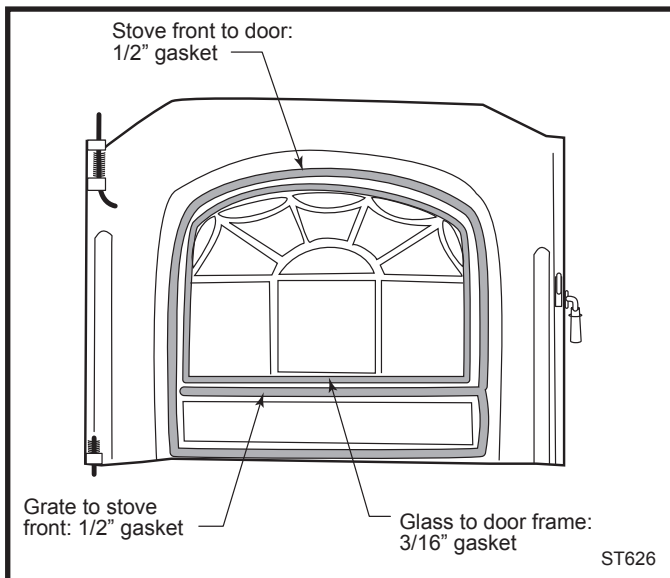

**Fig. 39** Two different gasket sizes are used to seal the front door.

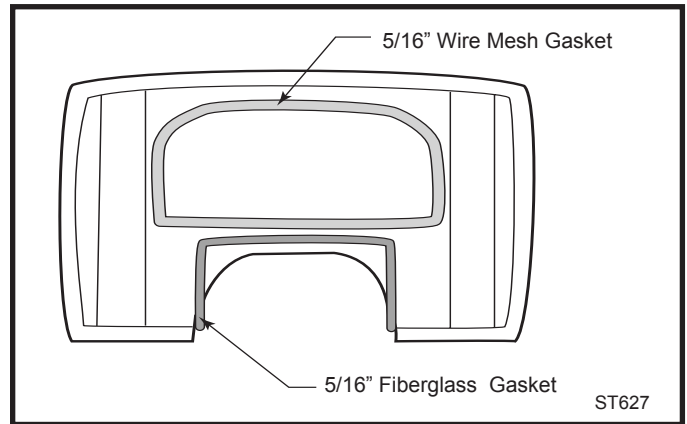

**Fig. 40** A 5/16" wire mesh gasket seals the griddle to the stove top. The flue collar is sealed with a 5/16" fiberglass gasket.

### Replace Broken Firebricks

If a firebrick breaks, replace only with Vermont Castings' custom firebricks, available from your local dealer.

Vermont Castings Group custom firebricks contain metal reinforcements that maintain the brick's integrity if it cracks. A brick that is cracked but still intact does not need to be replaced.

### A Clean Chimney System is Safer and Works Better

#### Learn to Recognize Creosote and Soot

When you first begin using the stove, check daily for creosote — a substance that can look like either thick tar or black, crisp flakes. Experience will show how often you need to clean to be safe. The frequency may even vary during the year. In the colder months when the hottest fires producing the least creosote are burned, you may need to clean less frequently. During the warmer months when creosote is more likely to result from cooler-burning fires and weaker draft, more frequent cleaning may be necessary.

At the very least, inspect the chimney and chimney connector twice monthly. Clean if necessary. Let the stove cool to check if a buildup of creosote or soot has occurred. If a significant layer of creosote has accumulated—1/8" (3mm) or more—it should be removed to reduce the risk of a chimney fire. Failure to keep the chimney and connector system clean can result in a serious chimney fire.

The conditions for a chimney fire develop like this: When wood is burned slowly, it produces tar and other organic vapors, which combine with expelled moisture to form creosote. The creosote vapors condense in the relatively cool chimney flue of a slow-burning fire. As a result, creosote residue accumulates on the flue lining. When ignited, this creosote makes an extremely hot fire within the flue system which can damage the chimney and overheat adjacent combustible material.

To reduce the amount of creosote that may form, remember to provide adequate air for combustion and to strive for small, intense fires rather than large, smoldering ones.

You can never be too safe. Contact your local fire authority for information on what to do in the event of a chimney fire, and have a clearly understood plan on how to handle one.

### **Inspect the Chimney Connector and Chimney Twice Monthly and Clean as Required**

Let the stove cool completely before you inspect the chimney. Then, use a strong light, and sight up through the flue collar into the chimney flue. If it is not possible to inspect the flue system this way, the stove must be disconnected to provide adequate viewing.

Clean the chimney using a specially designed chimney cleaning brush, the same size and shape as the flue liner, attached to flexible fiberglass rods designed for this purpose. Run the brush up and down the liner so that any deposits fall to the bottom of the chimney where they can be removed through the clean-out door. The chimney connector should be cleaned by disconnecting the sections, taking them outside, and removing any deposits with a stiff wire brush. Reinstall the connector sections after cleaning, being sure to secure the individual sections with three sheet metal screws per section.

If you are unable to inspect and/or clean the chimney system yourself, contact your local dealer or hire a qualified chimney sweep in your area to do the job.

### **Resolute Acclaim Maintenance Schedule**

#### **Stove:**

##### **Daily:**

- Ashes should be removed before they reach the top of the ash pan. Check at least once a day.
- Keep the area around the stove clear of any combustible material.

##### **Two Months:**

- Check door handle to be sure it is working properly. Gasketing becomes compressed after a period of time.
- Check leg bolts and heat shield screws; tighten if necessary.
- Vacuum exhaust area on either side of secondary combustion package.

##### **Yearly Spring Cleaning:**

- Check gasketing for wear, and replace if necessary.
- Vacuum exhaust area on either side of secondary combustion package.
- Remove ashes from the ash pan and replace with a moisture absorbing material (such as kitty litter) to keep the interior of the stove dry.
- Clean the dust from the inner sides of bottom, rear or pipe heat shields if your stove is equipped with them. Clean surfaces are better heat reflectors than dirty surfaces.
- Touch up the black paint.

##### **Chimney Connector:**

###### **Two Weeks:**

- Inspect the chimney connector and chimney. Clean if necessary.

###### **Two Months:**

- Inspect the chimney and chimney connector. Pay particular attention to the horizontal runs of chimney connector, and the elbows. Clean the system if necessary.

##### **Yearly Spring Cleaning:**

- Disassemble the chimney connector and take it outdoors for inspection and cleaning. Replace weak sections of connector.
- Inspect the chimney for signs of deterioration. Repairs to a masonry chimney should be made by a professional mason. Replace damaged sections of prefabricated chimney. Your local dealer or a chimney sweep can help determine when replacement is necessary.
- Thoroughly clean the chimney.

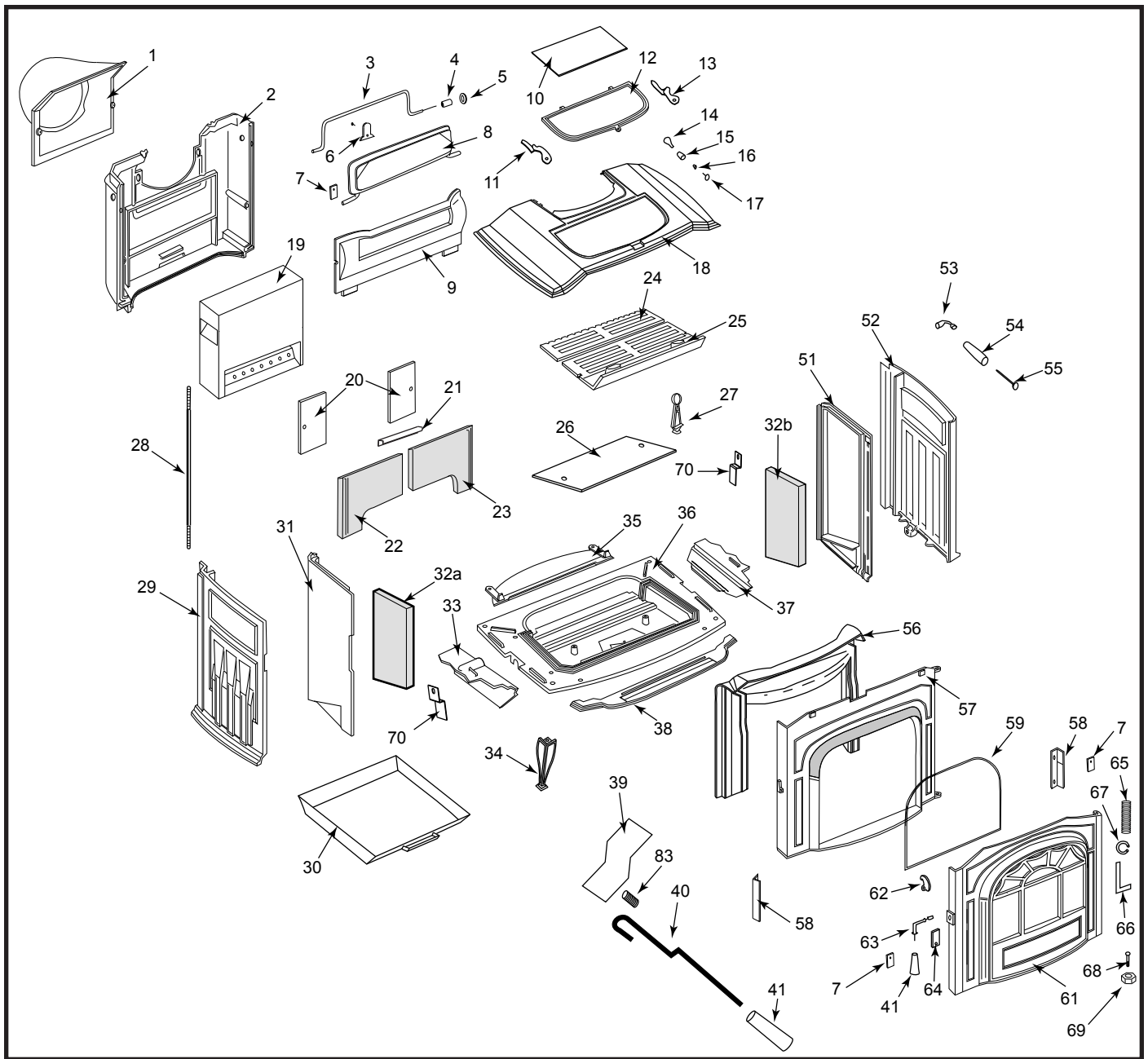

Vermont Castings Group reserves the right to make changes in design, materials, specifications, prices and discontinue colors and products at any time, without notice.

# Resolute Acclaim Woodburning Stove

## Model 2490

Item Description	Part Number
1. Flue Collar	See Chart Pg. 30
2. Back	1301860
3. Damper Rod	1600853
4. Spacer	1201780
5. Washer - 3/8"	1202488
6. Damper Ramp	1301811
7. Damper Tab	1601488
8. Damper	1301829
9. Upper Fireback	1301805

Item Description	Part Number
10. Flue Cover	See Chart Pg. 30
11. Left Griddle Quad (Pre-2010)	1301807
11a. Left Griddle Quad	30005118
12. Griddle	1306356
13. Right Griddle Quad (Pre-2010)	1301832
13a. Right Griddle Quad	30005119
14. Griddle Handle Stub	1600881
15. Griddle Knob	1600661
16. Bushing	1201900

# Resolute Acclaim Woodburning Stove

## Model 2490 (continued)

Item Description	Part Number
17. Griddle Handle Screw	1201308
18. Top	See Chart Pg. 30
19. Combustion Package	1602497
20. Sealing Plates (2)	1301859
21. Arch Brick Retainer	30006590
22. Left Arch Brick*	30006588
23. Right Arch Brick*	30006589
24. Rear Grate	1301851
25. Front Grate	1301852
26. Pit Plate	1301804
27. Andiron (2)	1301806
28. Tie Rod (4)	1601640
29. Left End	See Chart Pg. 30
30. Ash Pan	5005775
31. Left Inner Side	1301855
32a. Left Side Firebrick	1600153
32b. Right Side Firebrick	30004689
33. Left Shoulder Plate	1301863
34. Leg (4)	See Chart Pg. 30
35. Package Support Plate	1301809
36. Bottom	1301854
37. Right Shoulder Plate	1301864
38. Ashlip	See Chart Pg. 30

Item Description	Part Number
39. Air Valve	1301814
40. Air Valve Shaft	1600621
41. Air Valve Handle / Door Handle	1600663
51. Right Inner Side	1301856
52. Right End	See Chart Pg. 30
53. Damper Handle Stub w/ Set Screw	30002720
54. Damper Handle	1600664
55. Damper Handle Screw	1201310
56. Air Manifold	1301803
57. Front	1301861
58. Glass Retainer (2)	1601399
59. Glass	1401120
61. Door	See Chart Pg. 30
62. Door Hook	1600155
63. Door Handle Shaft	1600623
64. Latch Retainer	1201843
65. Compression Spring	1600551
66. Upper Door Pin	1600550
67. C-Clip	1600553
68. Pin, Hinge Bottom	1600419
69. Nut, Hex 5/16-18	1203279
70. Bracket, Side Brick (2)	30006591

**\*NOTE:** For stoves built before May 2013, order Brick Replacement Kit #30006595.

Shell Enamel Parts - Resolute Acclaim								
Enamel Color	Top	Left Side	Right Side	Flue Collar	Flue Cover	Ashlip	Door	Leg
Classic	1301862	1301857	1301858	1301816	1301817	1301819	1301865	1301833
Biscuit	30003118	30003119	30003120	30003121	30003122	30003117	30003123	30003116
Bordeaux	30006778	30006779	30006780	30006781	30006782	30006777	30006783	30006776
Brown Majolica	30004887	30004888	30004889	30004890	30004891	30004886	30004892	30004885

# Warranty

## Limited 3 Year Warranty

Vermont Castings Group warrants that this woodburning stove will be free of defects in material and workmanship for a period of three years from the date you receive it, except that the catalyst, thermostat assembly, handles, glass door panels, cement, and gasketing shall be warranted as described below.

Vermont Castings Group will repair or replace, at its option, any part found to be defective upon inspection by a Vermont Castings, Authorized Dealer. The customer must return the defective part or the stove, with shipping prepaid, to the Authorized Dealer or pay for any Authorized Dealer in-home travel fees or service charges for in-home repair work. It is the dealer's option whether the repair work will be done in the customer's home or in the dealer's shop. If, upon inspection, the damage is found to be the fault of the manufacturer, repairs will be authorized at no charge to the customer for parts and/or labor.

Any woodburning stove or part thereof that is repaired or replaced during the limited warranty period will be warranted under the terms of the limited warranty for a period not to exceed the remaining term of the original limited warranty or six (6) months, whichever is longer.

## Limited 1 Year Warranty

The following parts of the woodburning stove are warranted to be free of defects in material and workmanship for a period of one year from the date you receive it: The thermostat assembly, handles, glass door panels, cement, and gasketing. Any of these items found to be defective will be repaired or replaced at no charge, upon the return of the part with postage prepaid to a Vermont Castings Authorized Dealer.

Any part repaired or replaced during the limited warranty period will be warranted under the terms of the limited warranty for a period not to exceed the remaining term of the original limited warranty or six (6) months, whichever is longer.

## Limited Catalyst Warranty

The catalyst will be warranted for a six year period as follows: If the original catalyst or a replacement catalyst proves defective or ceases to maintain 70% of its particulate emission reduction activity (as measured by an approved testing procedure) within 24 months from the date the stove is received, the catalyst itself will be replaced free.

From 25 - 72 months a pro-rated credit will be allowed against a replacement catalyst and the cost of labor necessary for its installation at the time of replacement.

For stove purchases made after June 30, 1990, a third year (25 - 36 months) of no charge replacement will be made when combustor failure is due to thermal degradation of the substrate (crumbling of ceramic material). The customer must pay for any in-home travel fees, service charges, or transportation costs for returning the stove to the Authorized Dealer.

Amount of Time Since Purchase	Credit Towards Replacement Cost
0 - 24 months	100%
25 - 36 months	50 %
37 - 48 months	30%
49 - 60 months	20%
61 - 72 months	10%

Any replacement catalyst will be warranted under the terms of the catalyst warranty for the remaining term of the original warranty. The purchaser must provide the following information in order to receive a replacement catalyst under the terms of this limited warranty:

1. Name, address and telephone number.
2. Proof of original purchase date.
3. Date of failure of catalyst.
4. Any relevant information or circumstances regarding determination of failure.
5. In addition, the owner must return the failed catalyst.

## Exclusions & Limitations

1. This warranty is transferable; however, proof of original retail purchase is required.
2. This warranty does not cover misuse of the stove. Misuse includes overfiring which will result if the stove is used in such a manner as to cause one or more of the plates to glow red. Overfiring can be identified later by warped plates and areas where the paint pigment has burned off. Overfiring in enamel fireplaces is identified by bubbling, cracking, chipping and discoloration of the porcelain enamel finish. Vermont Castings Group offers no warranty on chipping of enamel surfaces. Inspect your woodburning stove prior to accepting it for any damage to the enamel.
3. This warranty does not cover misuse of the stove as described in the Owner's Guide, nor does it cover an stove which has been modified unless authorized by a Vermont Castings Group representative in writing. This warranty does not cover damage to the stove caused by burning salt saturated wood, chemically treated wood, or any fuel not recommended in the Owner's Guide.
4. This warranty does not cover a stove repaired by someone other than a Vermont Castings Authorized Dealer.
5. Damage to the unit while in transit is not covered by this warranty but is subject to a claim against the common carrier. Contact Vermont Castings Authorized Dealer from whom you purchased your stove or Vermont Castings Group if the purchase was direct. (Do not operate the stove as this may negate the ability to process the claim with the carrier.)
6. Claims are not valid where the installation does not conform to local building and fire codes or, in their absence, to the recommendations in our Owner's Guide.
7. The salt air environment of coastal areas, or a high-humidity environment, can be corrosive to the porcelain enamel finish. These conditions can cause rusting of the cast iron beneath the porcelain enamel finish, which will cause the porcelain enamel finish to flake off. This warranty does not cover damage caused by a salt air or high-humidity environment.
8. Vermont Castings Group shall have no obligation to enhance or update any unit once manufactured.

IN NO EVENT SHALL Vermont Castings Group BE LIABLE FOR INCIDENTAL AND CONSEQUENTIAL DAMAGES. ALL IMPLIED WARRANTIES, INCLUDING THE IMPLIED WARRANTIES OF MERCHANTABILITY AND FITNESS, ARE LIMITED TO THE DURATION OF THIS WRITTEN WARRANTY. THIS WARRANTY SUPERCEDES ALL OTHER ORAL OR WRITTEN WARRANTIES.

Some states do not allow the exclusion or limitations of incidental and consequential damages or limitations on how long an implied warranty lasts, so the above limitations may not apply to you. This warranty gives you specific rights and you may have other rights which vary from state to state.

## How to Obtain Service

If a defect is noted within the warranty period, the customer should contact a Vermont Castings Authorized Dealer or Vermont Castings Group if the purchase was direct with the following information:

1. Name, address, and telephone number of the purchaser.
2. Date of purchase.
3. Serial number from the label on the back.
4. Nature of the defect or damage.
5. Any relevant information or circumstances, e.g., installation, mode of operation when defect was noted.

A warranty claim will then start in process. Vermont Castings Group reserves the right to withhold final approval of a warranty claim pending a visual inspection of the defect by authorized representatives.

**Vermont Castings Group**

149 Cleveland Drive • Paris, Kentucky 40361  
[www.vermontcastingsgroup.com](http://www.vermontcastingsgroup.com)