



## INSTALLATION INSTRUCTIONS & MAINTENANCE GUIDE

**VENT CONNECTOR FOR PELLET FUEL APPLIANCES AND  
OTHER LOW TEMPERATURE APPLICATION**

**LISTED  
TO ULC-S609 & UL641**



**LISTED**



**LISTED**

**A MAJOR CAUSE OF VENT RELATED  
FIRES IS FAILURE TO MAINTAIN  
REQUIRED CLEARANCES (AIR SPACES)  
TO COMBUSTIBLE MATERIALS.**

**IT IS OF THE UTMOST IMPORTANCE  
THAT THIS VENTING BE INSTALLED  
ONLY IN ACCORDANCE WITH THESE  
INSTRUCTIONS.**



**PLEASE READ ALL INSTRUCTIONS BEFORE BEGINNING YOUR INSTALLATION.  
FAILURE TO INSTALL THIS SYSTEM IN ACCORDANCE WITH THESE  
INSTRUCTIONS WILL VOID THE CONDITIONS OF CERTIFICATION AND THE  
MANUFACTURERS WARRANTY. KEEP THESE INSTRUCTIONS IN A SAFE  
PLACE FOR FUTURE REFERENCE.**



Selkirk Corporation  
1301 W. Pres. George Bush Highway  
Richardson, TX 75080-1139  
Toll Free 1.800.992.VENT (8368)

[www.selkirkcorp.com](http://www.selkirkcorp.com)

Selkirk Canada Corporation  
P. O. Box 526, Depot 1,  
Hamilton, On, L8L 7X6  
Toll Free 1.888.SELKIRK (735.5475)

Model PL Vent is listed to Canadian Standards ULC-S609 for Low Temperature Vents Type L and ULC/ORD-C441 for Pellet Vents. It is also listed to the American Standard UL-641 for Type L Low Temperature Venting Systems. Model PL Vent is approved for venting listed pellet and corn stoves that do not exceed flue temperatures of 570° F (300° C).

## PLANNING AND LAYOUT

1. The minimum clearance required between the vent and combustible material is 25mm (1"). Do not fill this space with insulation or any other material. The air space is required for the safe operation of the vent.

2. Contact local building authority and your insurance provider before installation to determine if a permit and/or inspection is required.

3. If you choose to have your product professionally installed, we recommend these products be installed by professionals who are certified in Canada by WETT ( Wood Energy Technology Transfer) or by l'APC (l'Association des professionnels du chauffage) or in the U. S. by NFI (National Fireplace Institute).

4. When locating your appliance, consider the building structure to ensure the vent will not interfere with any ceiling joists, roof rafters, wall studs, water pipes or electrical wiring. It may be easier to relocate the appliance than to rework the building structure.

5. Read the appliance installation instructions for any further layout restrictions.

6. A Black Ceiling Support or Support Assembly will support up to 15.2m (50 ft) of vent.

7. The rain cap of a vertical (through the roof) installation must be at least 600mm (24") above the roof line when installed in the US and 900mm (36") when installed in Canada. See Figure 3.

8. If the Vent extends five feet or more above the roof penetration, Roof Brace Poles and a Roof Brace Band must be used to provide lateral support.

9. In geographical regions experiencing sustained low ambient temperatures it is recommended to enclose exterior vents below the roof line. This should help reduce condensation, soot accumulation, and poor drafting. Since corn has a higher moisture content than pellet, it is more susceptible to condensation formation in certain installations. Install the appliance with a minimum of vent exposed to the cold temperatures outside of the house envelope.

10. A vent must be enclosed in any inhabited space above the appliance. In a building other than a one or two family dwelling, the enclosure material shall have a fire resistance rating at least equal to the adjacent floor or ceiling material.

11. Most pellet burning appliances have powered exhausts and may be suitable for horizontal venting. However, a vertical vent will generally outperform a horizontal vent in exhausting flue gases.

12. For Horizontal Termination restrictions may apply. When installed in Canada ULC/ORD-C441 have specific restrictions (see Section 2.2).

When installed in the USA, refer to NFPA 211 for restrictions also shown in Section 2.3 of these instructions.

13. To ensure a good gas tight seal for positive pressure venting the application of an RTV high temperature silicone to the male collar of the joint is recommended (see Figure 1).

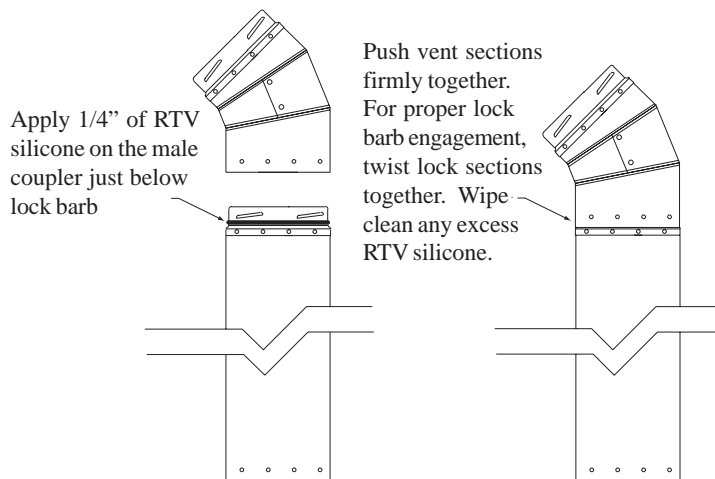

FIGURE 1

SELKIRK CANADA CORPORATION WILL NOT BE HELD LIABLE FOR ANY DAMAGES OR LOSSES ARISING OUT OF IMPROPER CARE, HANDLING, INSTALLATION OR USE OF THIS VENT.

TABLE 1 - FRAMING DIMENSIONS		
	3" Dia.	4" Dia.
Black Ceiling Support (BCS)	254mm x 254mm 10 x 10	279mm x 279mm 11 x 11
Support Assembly (SA)	254mm x 254mm 10 x 10	279mm x 279mm 11 x 11
Firestop (FS)	254mm x 254mm 10 x 10	279mm x 279mm 11 x 11
Thimble (THD, THDS)	254mm x 254mm 10 x 10	279mm x 279mm 11 x 11

## 1 INTERIOR VENT INSTALLATION

1.1 General VENT layout is shown in Figure 2.

1.2 Position the appliance in its desired location according to the appliance installation instructions.

1.3 Install a PIPE ADAPTOR or UNIVERSAL PIPE ADAPTOR onto the appliance's flue collar.

1.4 If the flue collar exits the appliance horizontally, a 90 degree ELBOW or TEE section must be used to turn the VENT vertical.

1.5 Use a plumb line to determine the location of VENT penetration at the ceiling.

1.6 Cut a hole in the ceiling and frame to the appropriate opening size (see Table 1). Framing material shall be the same as that of adjacent joist material.

1.7 Install the BLACK CEILING SUPPORT (BCS) from below the joist level and fasten with 4 x 1.5" spiral nails or screws (see Figure 2).

1.8 Alternatively, a SUPPORT ASSEMBLY (SA) may be used in place of the BCS. The SUPPORT ASSEMBLY fits into the ceiling opening from below and is fastened to joists with 4 x 1.5" spiral nails or screws (see Figure 3).

1.11 FIRESTOPS are required where the Vent penetrates a floor or ceiling. Cut a hole of the appropriate size in the ceiling/floor and install the FIRESTOP from above or below the joist. Fasten the FIRESTOP with nails through the corners as per Figure 2. An Attic Insulation Shield is also available where the venting passes into an attic space and is installed from above. When an Attic Insulation Shield is installed the Firestop installed from below is then optional as per Figure 2.

1.12 Where the vent system penetrates the air/vapour barrier, the barrier must be sealed to the ceiling joist or firestop.

1.13 Elbows may be used to offset the VENT when it becomes necessary in order to clear a joist or rafter. Keep use of elbows to a minimum as they reduce draft capacity of a vent.

1.14 Continue the VENT up through the roof line.

1.15 Slide the FLASHING over the Vent until it sits on the roof line. Slip the upper side of the FLASHING base under the roof shingles and lay the lower side over the shingles. Nail the FLASHING to the roof with a minimum of 8 roofing nails. Seal the FLASHING base with an appropriate roofing sealant. Ensure that the required 25mm (1") clearance is maintained to the vent.

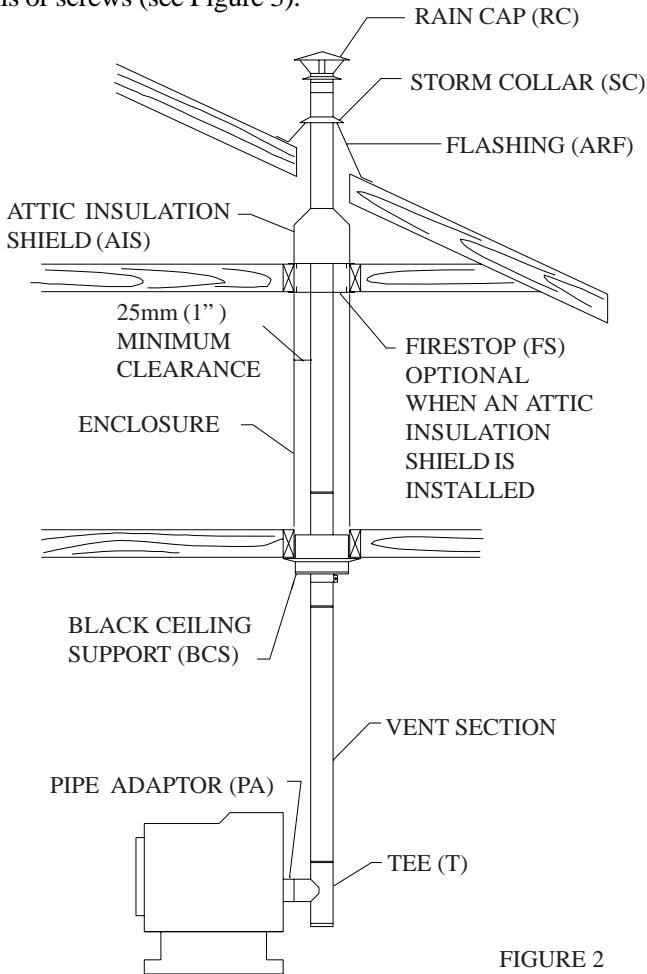

FIGURE 2

1.9 Insert the first VENT section through the SUPPORT and tighten the clamp screw. Additionally fasten the vent with four screws (max 1/2" long) through the support collar and into the vent skin.

1.10 Install the next VENT section(s) above the first. Apply 1/4" bead of RTV if necessary as per Figure 1. Twist lock sections together with a clock wise turn. Before twisting, push vent sections firmly together for proper lock barb engagement. Enough twisting force must be applied to ensure that the collars will compress the gasket material.

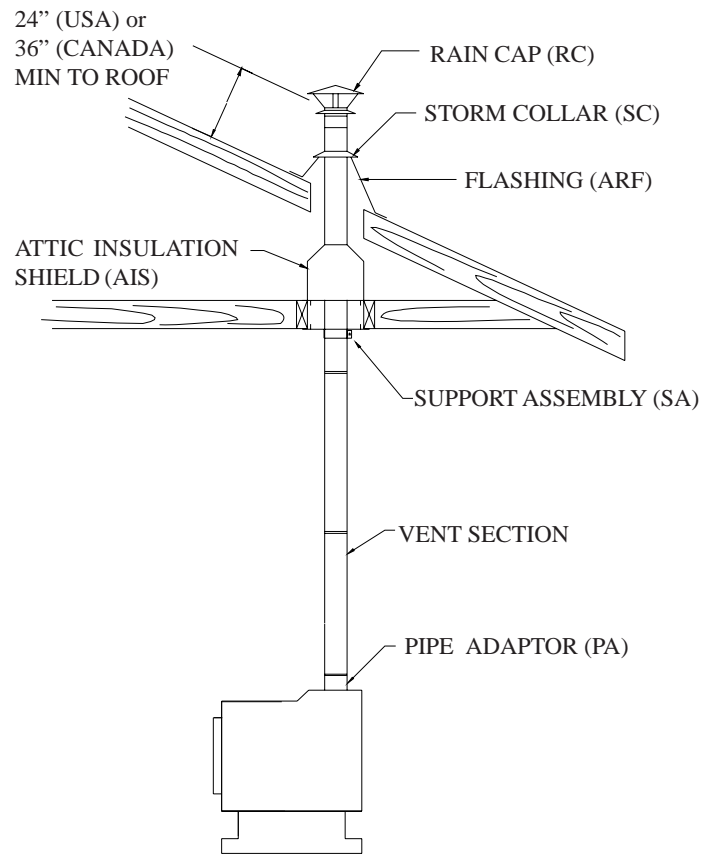

FIGURE 3

1.16 Slide the STORM COLLAR down the Vent until it sits on the FLASHING. Apply a bead of silicone around the top of the STORM COLLAR.

1.17 Set the RAIN CAP onto the top VENT section and twist lock it to the top VENT section (see Figure 3).

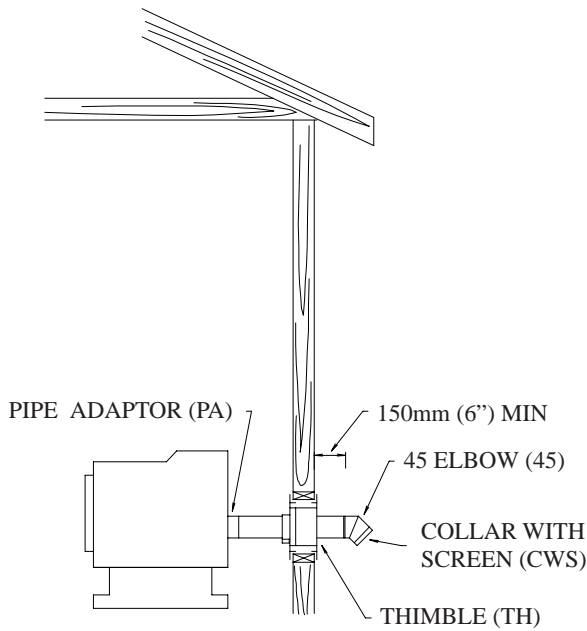

FIGURE 4

## 2 HORIZONTAL INSTALLATION

2.1 General VENT layout is shown in Figures 4 and 6.

In selecting the location for the appliance and the vent, it is necessary to take into account the rules of ULC/ORD-441 and NFPA 211.

2.2 When installed in Canada:

For a Horizontal Termination ULC/ORD-C441 has the following restrictions: Vent length must not exceed 1200mm (48"). The Termination must not be located:

- A) Within 1.8 m (6 ft) of a mechanical air supply inlet to a building.
- B) Above a gas meter/regulator within 900 mm (36") horizontally of vertical centre of the regulator.
- C) Within 1.8 m (6 ft) of a gas service regulator vent outlet.
- D) Less than 300 mm (12") above grade.
- E) Within 1 m (3 ft) of a building opening or air inlet of another appliance.

2.3 When installed in the USA, refer to NFPA 211 for rules for distance of exit terminal from windows and openings: The exit terminal of a mechanical draft system, other than a direct vent appliance (sealed combustion system appliance), shall be located accordance with the following:

- 1) Not less than 3 ft (1 m) above any forced air inlet located within 10 ft (3 m).
- 2) Not less than 4 ft (1200mm) below, 4 ft.(1200mm) horizontally from or 1 ft (300mm) above any door, window or gravity air inlet into any building, and
- 3) Not less than 2 ft (600mm) from an adjacent building and not less than 7 ft (1.2m) above grade when located adjacent to public walkways.

2.4 Position the appliance in the desired location and according to the appliance installation instructions.

2.5 Install a PIPE ADAPTOR or a UNIVERSAL PIPE ADAPTOR onto the appliance's flue collar.

2.6 Cut a hole in the building wall of the appropriate size for the VENT (see Table 1).

2.7 A WALL THIMBLE must be used when the VENT passes through a combustible wall. The THIMBLE splits into two sections. Install the section with the support clamp from inside the building. Install the other section from outside the building. Fasten the THIMBLE to the wall with nails or screws at the THIMBLE's corners. The WALL THIMBLE is to be used on walls ranging in width from 5" - 9". If a wall 9" to 18" (max) in thickness is to be passed through, it is permissible to field fabricate a WALL THIMBLE EXTENSION of galvanized sheet metal of 26 gauge (see FIGURE 5). The EXTENSION can be trimmed so that it overlaps each of the THIMBLE sleeves by at least 75mm (1"). It is to be attached to the female end (non crimped) of the THIMBLE with three (3) sheet metal screws. Proceed with the installation as described above.

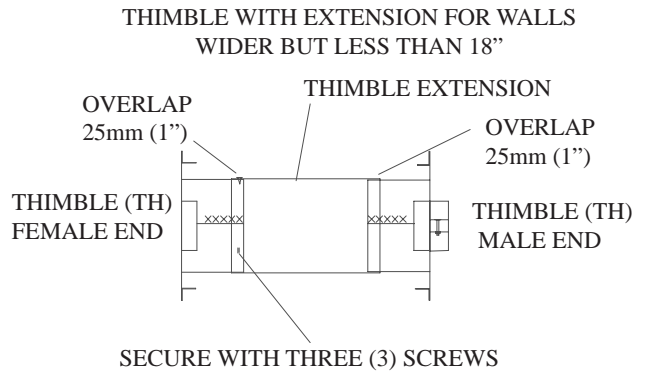

FIGURE 5

2.8 Insert the first VENT section through the THIMBLE and twist connect its female end to the PIPE ADAPTOR on the appliance.

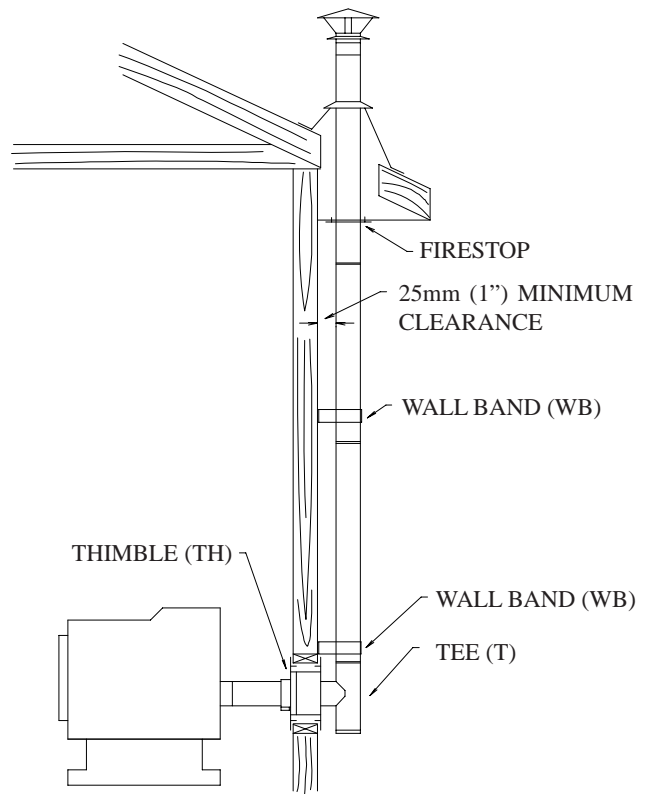

FIGURE 6

2.9 Use additional VENT sections as necessary. The VENT must extend at least 152 mm (6") outside of the combustible wall.

2.10 Tighten the THIMBLE's clamp screw to secure the VENT.

2.11 There are two alternative vent terminations. A 45 degree ELBOW may be used together with a COLLAR WITH SCREEN as shown in Figure 4, or as shown in section 4 and Figure 7.

### **3 EXTERIOR VERTICAL INSTALLATION**

3.1 Follow instructions 2.1 to 2.7 (see Figure 6).

3.2 Install a TEE section to the vent penetrating the wall.

3.3 Run the VENT vertically up the wall, ensuring to maintain a minimum of 25 mm (1") clearance between the wall and VENT.

3.4 A WALL BAND must be installed just above the TEE and at least every 1.8 m (6 feet) of VENT rise.

3.5 The VENT may be run up through a roof overhang. In this case, use a FLASHING, STORM COLLAR, and RAIN CAP as in instructions 1.15 to 1.17.

### **4 EXTERIOR - SHORT RISE INSTALLATION**

4.1 Follow instructions 3.1 to 3.4.

4.2 After a rise of at least 900mm (3ft) (consult appliance manufacturer's installation instructions for minimum vent rise), install a 90 DEGREE ELBOW aimed out from the building wall.

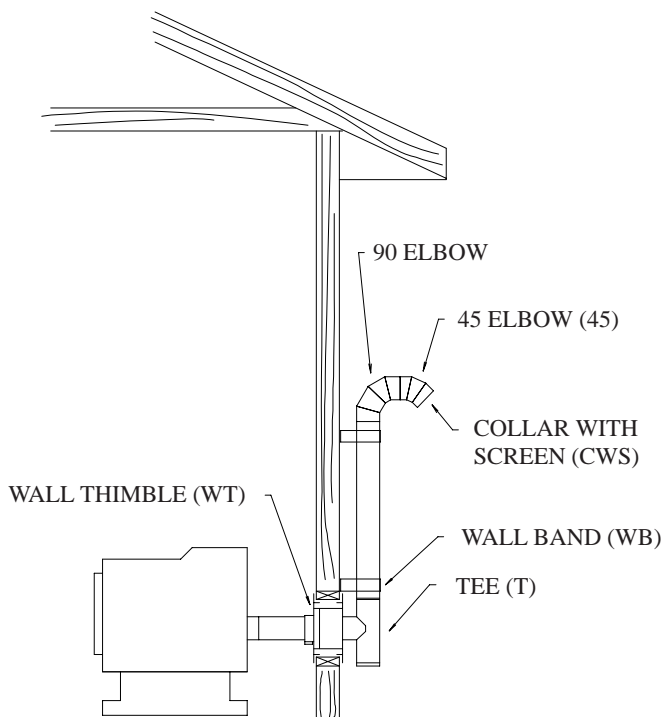

FIGURE 7

4.3 Attach a 45 DEGREE ELBOW to the 90 DEGREE ELBOW, aiming the second elbow down toward the ground. Terminate the vent with a COLLAR WITH SCREEN fastened to the 45 DEGREE ELBOW (see Figure 7).

4.4 This configuration will help prevent blockage of vent by snow drifts. Also the vertical rise will improve drafting and allow for easier cleaning of the TEE by removal of the cleanout.

4.5 Appliance manufacturers will recommend a minimum vent rise, check your appliance installation instructions for recommendations and/or requirements.

### **5 MAINTENANCE AND CLEANING INSTRUCTIONS**

5.1 With a new installation, the vent should be inspected frequently (every two weeks) to determine the rate of creosote formation. When familiar with the appliance and chimney characteristics, the vent should be inspected at least once every two months during the heating season to determine if a creosote or soot build-up has occurred. Accumulation of creosote or soot build-up of 1/16" or more, must be removed to reduce the risk of a chimney fire. The vent shall be inspected annually and cleaned as often as maybe necessary to keep the vent free from dangerous accumulation of combustible deposits.

5.2 Use a plastic brush to clean your vent. A metal brush may scratch the vent liner and lead to premature corrosion.

5.3 To reduce corrosion in the liner the vent must be thoroughly cleaned within 48 hours of shutting down the appliance for the season and all soot removed from the vent system. Vent deposits will have their most corrosive effect during humid summer weather. Ensure that only dry shelled corn at 14-15% moisture content or less is burn.

5.4 Vent installation must provide access for inspection and cleaning.

5.5 Do not use chemical cleaners in this vent system. They do not eliminate the need for manual cleaning and may be corrosive to vent materials. This is in conjunction with a complete evaluation and visual inspection of the system by a professional chimney sweep.

5.6 Vent exterior may be painted with a HEAT RESISTANT paint. This will extend its life and improve the appearance. To improve adhesion to the Vent, degrease, clean and prime before painting. Follow the paint manufacturers instructions.

5.7 Horizontal vent terminations may tend to distribute combustion by-products in a manner which leads to discolouring of building walls. This condition is caused by the system configuration and does not indicate a failure of the vent cap.

## INSTALLATION INFORMATION

Keep in a safe place for future reference

CHIMNEY MODEL: \_\_\_\_\_

TYPE OF APPLIANCE: \_\_\_\_\_

INSTALLATION DATE: \_\_\_\_\_

DESCRIPTION OF INSTALLATION (Chimney and Flue Pipe Configuration) \_\_\_\_\_

### ***PURCHASED FROM:***

DEALER NAME: \_\_\_\_\_

Address: \_\_\_\_\_

City: \_\_\_\_\_

Province/State: \_\_\_\_\_

### ***INSTALLED BY:***

TECHNICIAN NAME: \_\_\_\_\_

Address: \_\_\_\_\_

City: \_\_\_\_\_

Province/State: \_\_\_\_\_



## PRODUCT REGISTRATION

Please register your Chimney with the Manufacturer.

Mail to: Selkirk Canada Corporation,  
Product Registration, P.O. Box 256, Depot 1, Hamilton, ON L8L 7X6

**Register Online @: [www.selkirkcorp.com](http://www.selkirkcorp.com)**

Name: \_\_\_\_\_

Address: \_\_\_\_\_

City: \_\_\_\_\_

Province/State: \_\_\_\_\_ Postal Code/Zip Code: \_\_\_\_\_

Chimney Model: \_\_\_\_\_ Installation Date: \_\_\_\_\_

Technician Name: \_\_\_\_\_ Address: \_\_\_\_\_