

# Installation & Operating Manual

**NOTICE: SAVE THESE INSTRUCTIONS**



**Model(s):**

**TLC 2000 Coal/Wood Stove**

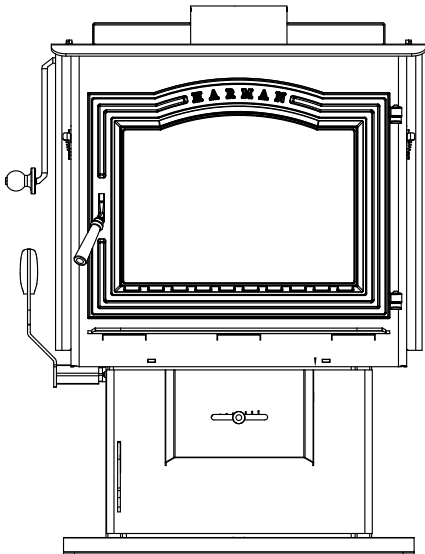

## WARNING



### HOT SURFACES!

Glass and other surfaces are hot during operation and cool down.

**Hot glass will cause burns.**

- Do not touch glass until it is cooled
- NEVER allow children to touch glass
- Keep children away
- CAREFULLY SUPERVISE children in same room as stove.
- Alert children and adults to hazards of high temperatures.

**High temperatures may ignite clothing or other flammable materials.**

- Keep clothing, furniture, draperies and other flammable materials away.

## NOTE

To obtain a French translation of this manual, please contact your dealer or visit [www.legacystoves.com](http://www.legacystoves.com)

Pour obtenir une traduction française de ce manuel, s'il vous plaît contacter votre revendeur ou visitez [www.legacystoves.com](http://www.legacystoves.com)

## SAFETY NOTICE

**PLEASE READ THIS ENTIRE MANUAL BEFORE YOU INSTALL AND USE YOUR NEW ROOM HEATER. FAILURE TO FOLLOW INSTRUCTIONS MAY RESULT IN PROPERTY DAMAGE, BODILY INJURY, OR EVEN DEATH.**

**FOR USE IN THE U.S. AND CANADA. DO NOT INSTALL IN A MOBILE HOME.**

**IF THIS STOVE IS NOT PROPERLY INSTALLED, A HOUSE FIRE MAY RESULT. FOR YOUR SAFETY, FOLLOW INSTALLATION DIRECTIONS.**

**CONTACT LOCAL BUILDING OR FIRE OFFICIALS ABOUT RESTRICTIONS AND INSTALLATION INSPECTION REQUIREMENTS IN YOUR AREA.**

**CONTACT YOUR LOCAL AUTHORITY (SUCH AS MUNICIPAL BUILDING DEPARTMENT, FIRE DEPARTMENT, FIRE PREVENTION BUREAU, ETC.) TO DETERMINE THE NEED FOR A PERMIT.**

**CETTE GUIDE D'UTILISATION EST DISPONIBLE EN FRANCAIS. CHEZ VOTRE CONCESSIONNAIRE DE LEGACY.**

**SAVE THESE INSTRUCTIONS.**



Please copy your serial number from the label on your stove to the box below.

**SERIAL NUMBER**

15.5"

**LEGACY STOVES™**  
Solid Fuel Burning Room Heater  
Model "TLC 2000"



Report #/ Report # 135-28-4  
Tested to / Testé à U.L. 182-2011, UL 737-2011, and U.L.C-S627-00

This appliance is approved for installation into a shop.

**"PREVENT HOUSE FIRES"**

Install and use only in accordance with manufacturer's installation and operation instructions. In the absence of local codes, installation must meet minimum requirements of NFPA 211 in U.S.A. In Canada, local codes and local codes for precautions required for passing chimney through a combustible masonry construction. Flue connector pipe must be 6" diameter, minimum 24 MSG blue steel. Chimney must be factory built masonry construction.

**Contact Local Building or Fire Officials About Restrictions and Installation Inspection In Your Area. DO NOT CONNECT THIS UNIT TO A CHIMNEY FLUE SERVING ANOTHER APPLIANCE. U.S.A. - FOR USE WITH SOLID WOOD (AS A FIREPLACE) OR COAL FUEL ONLY. CANADA - COAL AND/OR WOOD WHERE LOCAL CODES ALLOW.**

**WARNING: The Use of Any Other Fuels is Not Permitted. Refer to operation section of the appliance manual. DO NOT Overfire - If Heater or chimney Connector Glows, You Are Overfiring.**

**Optional Blower ASH # 0008643:** Electrical Rating: 115 V.A.C., 60Hz, 1 AMP Maximum. Replace Power Cord (New) From Unit. Power variable in option no. 1-00-08643. Securely mount. Replace glass only with same ceramic, available from your dealer.

**WARNING:** Risk of Smoke and Flame Spillage. Operate Only With Doors Fully Open or Fully Closed. Firescreen Must Be in Place When Burning With the Door Open.

**DANGER: Risk of Fire or Explosion - Do Not Burn Garbage, Gasoline, Drain Oil or Other Flammable Liquids.**

**WARNING: Risk of Fire:**

**Do Not Store Fuel or Combustibles Within Marked Clearance Area. Inspect and Clean Chimney Frequently. Under Certain Conditions of Use, Creosote Buildup May Occur Rapidly.**

**Do Not Install a Grade Rack or Otherwise Elevate the Fire Above the Factory Installed Grates.**



**CAUTION - HOT WHILE IN OPERATION - DO NOT TOUCH - KEEP CHILDREN AND CLOTHING AWAY - CONTACT MAY CAUSE SKIN BURNS. SEE NAMEPLATE AND INSTRUCTIONS. KEEP FURNISHINGS AND OTHER COMBUSTIBLE MATERIALS A CONSIDERABLE DISTANCE AWAY FROM THE APPLIANCE.**

**ATTENTION: CHAUD LORS DU FONCTIONNEMENT - NE TOUCHEZ PAS L'APPAREIL - GARDEZ LES ENFANTS ET LES VÊTEMENTS ÉLOIGNÉS - TOUT CONTACT PEUT ENTRAÎNER DES BRÛLURES DE LA PEAU. RÉFÉREZ-VOUS À LA PLAQUE SIGNALÉTIQUE ET AU MODE D'EMPLOI. GARDEZ LE MOBILIER ET LES AUTRES MATÉRIEAUX COMBUSTIBLES BIEN À L'ÉCART DE L'APPAREIL.**

**CLEARANCE TO COMBUSTIBLES / DISTANCES MINIMALES DE SECURITE:**

Parallèle Installation	Inches / Millimètres
A Back Wall / Entre mur arriéré et l'appareil	16 / 405
B Side Wall To Unit / Entre mur latéral et l'appareil	18 / 457
C Top / Entre Plaque / Entre tuyau et le mur arrière	18 / 457
D Front / Entre tuyau et le mur latéral	27 / 685

**Sample Label - Consult actual unit label for accurate information.**



Floor Protection Requirements	Inches / Millimètres
G Sides / Côtés	8 / 203
H Front from glass/Door, par rapport au verre - USA	16 / 405
H Front from glass/Door, par rapport au verre - Canada	18 / 457
J Rear / Arrière - USA and Canada	8 / 203

Floor protection must be of a non-combustible material. It also be placed under any horizontal member of the floor, and extend a minimum of 6" (152mm) beyond each side of the connector.

Pour protéger le plancher, il faut sous le poêle un matériau non-combustible. Qui doit aussi être placé sous les parties horizontales - l'our de la pièce de bois et le matériau doit s'étendre à 6" (152 mm) de part et d'autre à 31 mm (1 1/4") au-delà de latéral du tuyau.

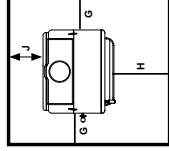

Made in U.S.A. of US and Imported parts. / Fabriqué aux États-Unis-d'Amérique par des pièces d'origine américaine et pièces importées.

**Date of Manufacture / Date de fabrication:**

2013 2014 2015 JAN FEB MAR APR MAY JUN JUL AUG SEP OCT NOV DEC

Manufactured by / Fabriqué par: Hearth and Home Technologies

Rev C

P.N. 3-90-06680

# Introduction

## Table of Contents

<b>Specifications</b> .....	6
<b>Operation</b> .....	8
<b>Building a Fire</b> .....	9-12
<b>Maintenance</b> .....	13-14
<b>Installation</b> .....	15-16
<b>Chimney System</b> .....	17-19
<b>Service Parts List</b> .....	20-22
<b>Warranty</b> .....	23-24
<b>Service &amp; Maintenance Log</b> .....	25

→ = Contains updated information

Please read this entire manual before you install and use your new room heater. Failure to follow instructions may result in property damage, bodily injury, or even death.

---

**DO NOT INSTALL IN A MOBILE HOME.**

---

SAVE THESE INSTRUCTIONS

**Appliance Certification.**

**Model:** TLC 2000

**Listed By:** OMNI-Test Laboratories, Inc

Report #: 135-S-28-4

**Type:** Solid Fuel Burning Room Heater

**Standard(s):** UL 1482-2011, UL 737-2011, ULC-S627-00

Note: This appliance is also approved for installation into a shop.



2393 Little Egypt Rd  
Harrisonville, PA 17228

# Carbon Monoxide (CO) Awareness

Carbon monoxide, referred to as CO, is a colorless, odorless gas that is produced during combustion of coal and other fuels. **CO fumes are toxic and can be fatal.**

The TLC 2000 is a natural draft system which relies on a properly designed chimney to remove CO and other combustion by-products from the stove.

Even though this stove is designed to be as safe as possible, it is important that you **install a CO detector**. This is true for oil, gas, or wood as well.

CO is not specifically heavier or lighter than air. Therefore, it is best to install the detector at table top level rather than on the ceiling like a smoke detector.

CO detectors are very sensitive and may sound an alarm for fumes other than CO or CO from sources other than the stove such as car or lawn mower exhaust.

If the alarm sounds

1. Increase ventilation by opening windows or doors.
2. Make sure the stove doors are closed and latched.
3. Check stove for normal operation.
4. Check for false alarm.
5. Have all occupants exit the building until the cause for the alarm is discovered and/or remedied.

## Never sleep in the same room with any coal burning stove

**NEVER USE GASOLINE, GASOLINE-TYPE LANTERN FUEL, KEROSENE, CHARCOAL LIGHTER FLUID, OR SIMILAR LIQUIDS TO START OR "FRESHEN UP" A FIRE IN THIS HEATER. KEEP ALL SUCH LIQUIDS WELL AWAY FROM THE HEATER WHILE IT IS IN USE.**

**DO NOT INSTALL A FLUE DAMPER IN THE EXHAUST VENTING SYSTEM OF THIS APPLIANCE.**

**DO NOT CONNECT THIS UNIT TO A CHIMNEY FLUE SERVING ANOTHER APPLIANCE**

**INSTALL VENT AT CLEARANCES SPECIFIED BY THE VENT MANUFACTURER.**



### CAUTION

**FAILURE TO FOLLOW THE INSTALLATION INSTRUCTIONS IN THIS MANUAL, OR USING MAKESHIFT COMPROMISES DURING INSTALLATION MAY RESULT IN PROPERTY DAMAGE, PERSONAL INJURY OR EVEN DEATH.**

**DO NOT CONNECT TO ANY AIR DISTRIBUTION DUCT OR SYSTEM.**

**DO NOT USE CHEMICALS OR FLUIDS TO START THE FIRE.**

**DO NOT BURN GARBAGE OR FLAMMABLE FLUIDS SUCH AS GASOLINE, NAPHTHA, OR ENGINE OIL**

**HOT WHILE IN OPERATION. KEEP CHILDREN, CLOTHING AND FURNITURE AWAY. CONTACT MAY CAUSE SKIN BURNS.**

**WHEN INSTALLING IN A TIGHTLY CONSTRUCTED HOME, A SOURCE OF FRESH AIR TO THE ROOM MAY BE NECESSARY FOR PROPER OPERATION OF THIS APPLIANCE.**

# Specifications

Weight . . . . . 462 lbs

Flue Size . . . . . 6 Inch

**Fuel:**

**USA:** Pea, Nut, or Stove coal, Cordwood with optional spark screen

**Canada:** Wood, or coal as above. Wood alone as local codes allow

Log Length Recommended . . . . . 16" with 18" Max

BTU/Hour Input . . . . . 72,000

\*Heating Capacity . . . . . 1,200 - 3,000 sq. ft

Blower Size (Optional) . . . . . 135cfm (Variable Speed)

**\*Heating capacity to be used as a guide only. See your local dealer for help in determining the product that best suits your heating needs based on climate and home efficiency.**

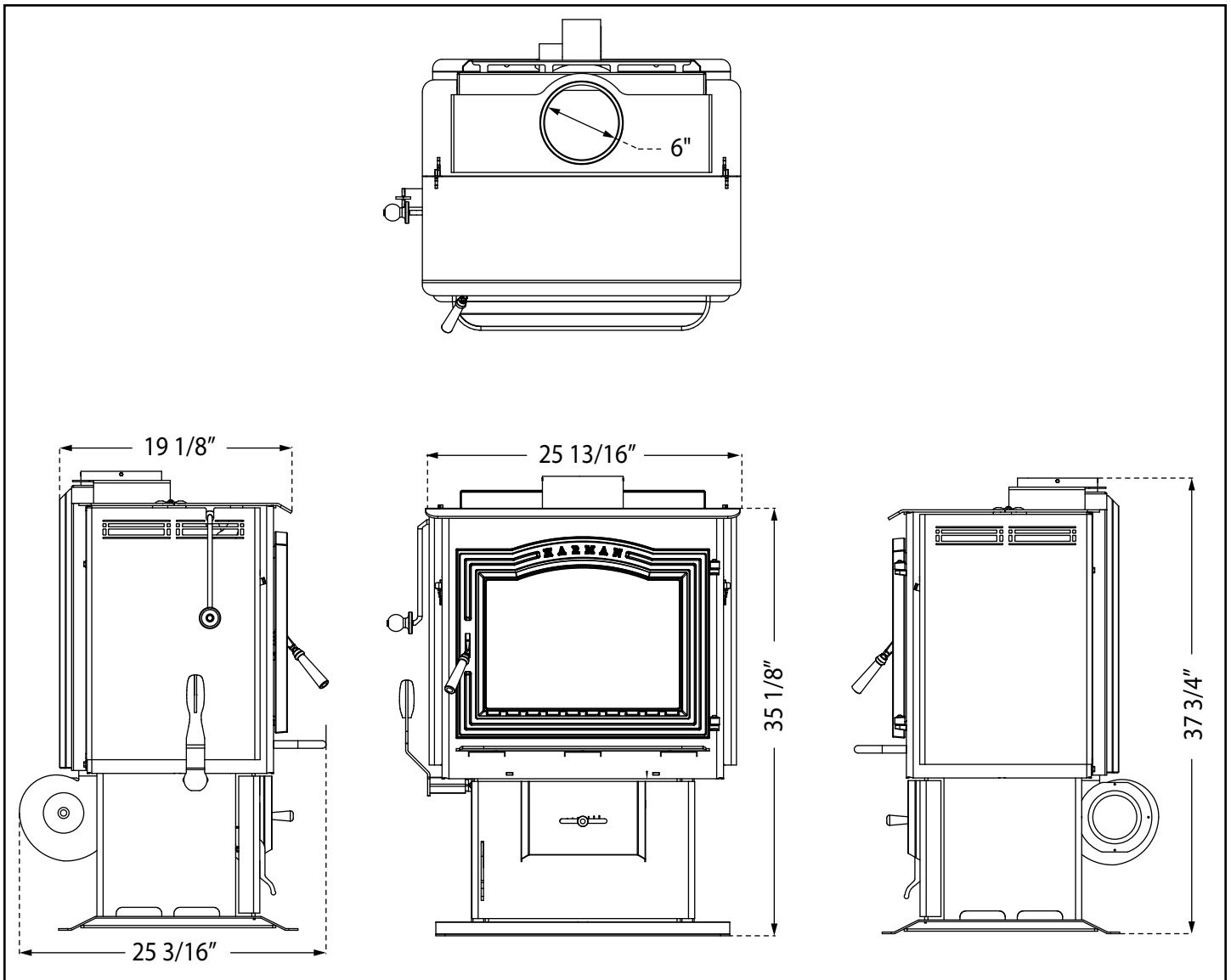

# Unit Overview

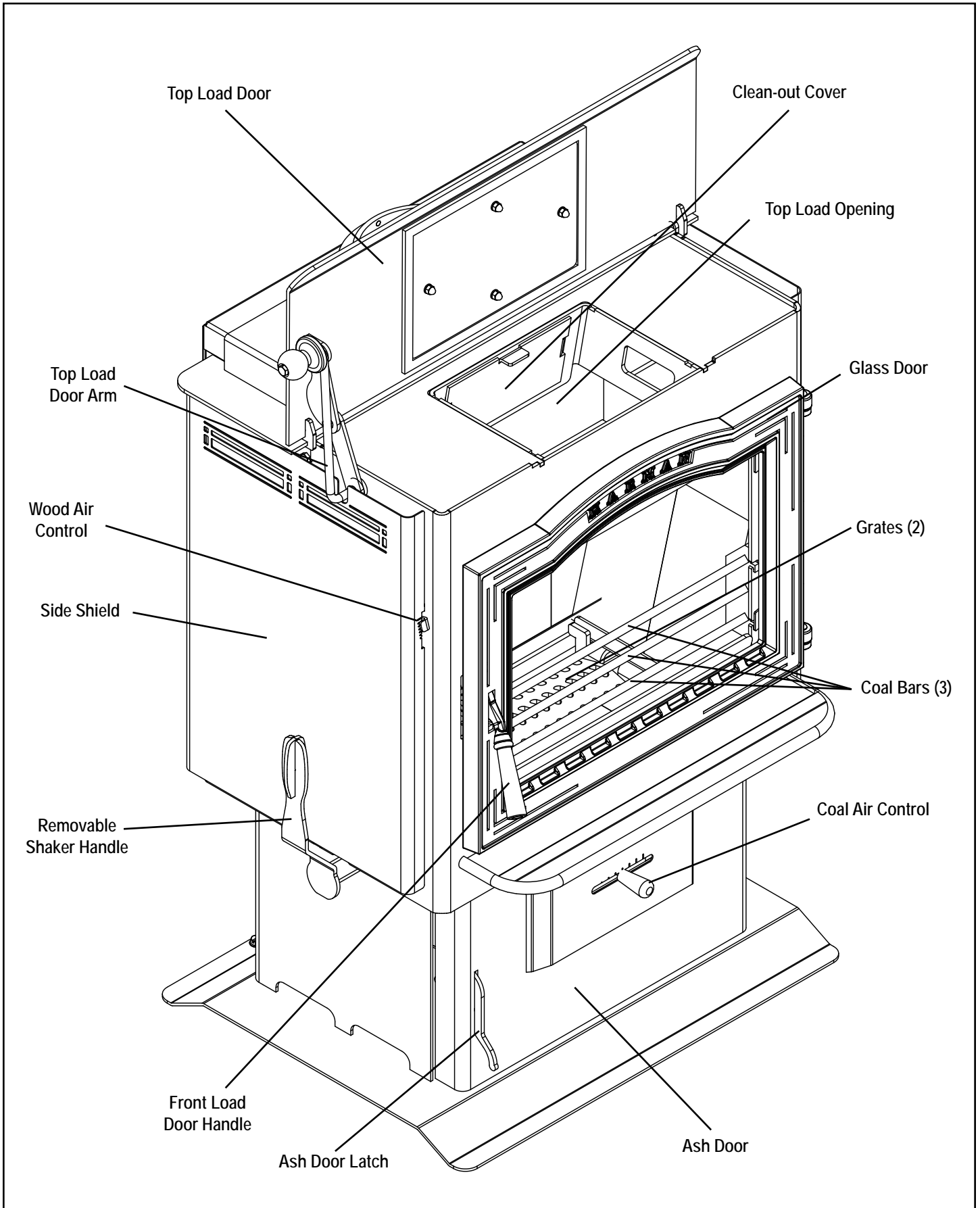

# Operation

## The Stove

### Doors

Your stove has a large glass-paneled door for loading and fire viewing, a separate smaller door for removing ashes and a top loading door. To open the glass door, turn the handle clockwise and pull out; to close the door, return the handle to an open 9 o'clock position and push in to engage the latch while turning the handle counterclockwise to the 6 o'clock position. To open the ash door, lift up on the handle and pull out. Close the door by pushing in and pushing the handle all the way down. To open the top load door move the wooden knob located on the left side of the stove front and upward until it locks the top open.

All doors must be closed while the stove is in normal operation, and the gaskets routinely examined for wear and replaced when necessary. The glass door may be left open and the opening covered with a screen when operating as a fireplace. Good door seals are important for maintaining control of the stove. Operating the stove with the ash door open, or with a door inadequately sealed, could create a serious overfiring condition (discussed later in this section).

### **NEVER OPERATE WITH MORE THAN ONE DOOR OPEN AT A TIME**

The glass used in your TLC 2000 is manufactured to exact standards to withstand the high heat of the fire, but like all glass, it must be treated with common sense and care. Never abuse the glass by slamming the door shut or striking the glass with a heavy object. If the glass is broken or damaged, do not operate the stove until it has been replaced. The coal bars must be installed to protect the glass. Never build a fire directly against the glass.

### Grates

The unique grate system of the TLC 2000 consists of two cast iron grates linked together to operate simultaneously when the external shaker handle is moved.

The purpose of the grate system is to support the coal bed while air flows up through the grates to the burning coal. The grates are also used to remove ashes from the bottom of the coal bed while the fire is burning. This is accomplished by shaking the shaker lever back and forth with short choppy strokes. This causes the ashes to fall through the grates into the ash pan. It is the special design of the Legacy Grates that allows longer intervals between refueling and shaking the grates.

### **REMOVAL OR MODIFICATION OF THIS GRATE SYSTEM MAY CAUSE A DANGEROUS SITUATION.**

## Fuels for USA

### Coal

Anthracite coal, pea or nut size, is the primary fuel for which the TLC 2000 is designed. Bituminous coal may also be burned but the results will vary due to the variation in bituminous coal from region to region.

### Wood

Wood may be burned in the TLC 2000 for the purpose of igniting coal.

Wood may also be burned with the glass door open and a screen in place to prevent sparks from escaping. This provides a real open fire atmosphere.

## Fuels for Canada

### Wood

Wood may be burned as a primary fuel, providing that your local and provincial codes allow it.

Wood may also be burned with the glass door open and a screen in place to prevent sparks from escaping.

### Coal

Anthracite coal, pea or nut size, may also be burned as a primary fuel for the TLC 2000. Bituminous coal may also be burned but the results will vary due to the variation in bituminous coal from region to region.

Fuel should be stored in a dry place, preferably indoors. Keep fuel outside the installation clearance area. Also, keep fuel away from all maintenance access areas.



### **CAUTION**

**USE OF FUELS OTHER THAN THOSE SPECIFIED WILL VOID THE PRODUCT WARRANTY AND MAY POSE A RISK TO PERSONAL HEALTH AND SAFETY.**

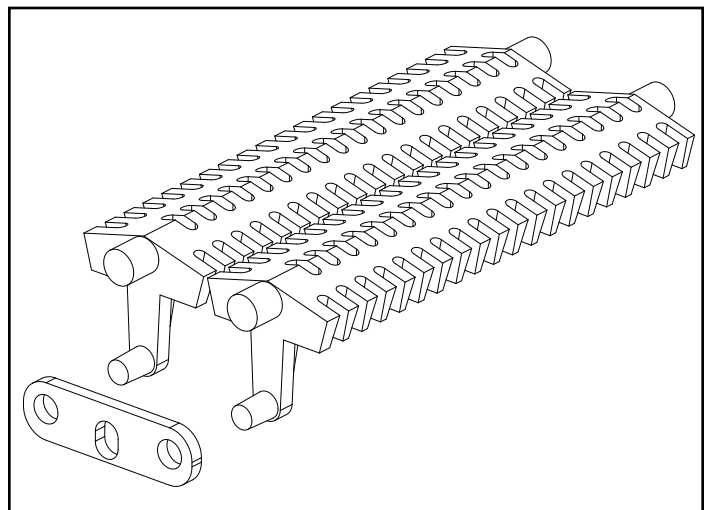

**Legacy Stoves TLC 2000 Grate System**



# Building & Maintaining a Fire

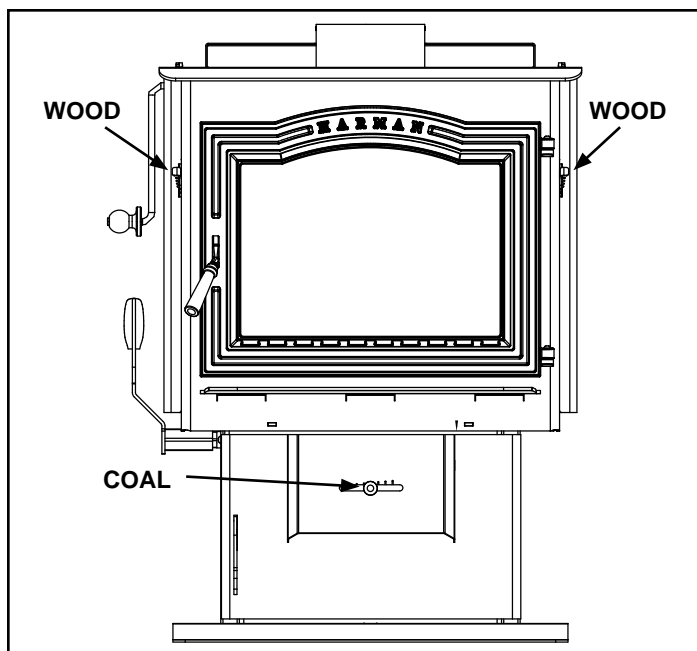

## Air Controls

### Coal

The primary air control for coal burning is a knob located on the bottom door. Sliding the knob to the left provides less air for a smaller fire. Sliding the knob to the right provides more air for a larger fire. When burning wood, this knob should be all the way to the left, closed.

### Wood

The primary air controls for wood burning are located on each side as shown above. Both controls should be adjusted equally. Air from these controls also provides a curtain of air across the glass to keep it clean. Move the controls down for less heat and up for more heat. When burning coal these controls should be in the down position.



**CAUTION**

**The wood controls are hot. Use the removable shaker handle or gloves to adjust these controls**

Coal must have air coming up through the coal bed in order to burn. Some air over the top of the coal helps burn gases. A small amount of air enters the top of the coal fire when the wood controls are in the down position.

Wood burns with top or bottom air; however, top air coming down across the glass to form an air curtain works best and keeps the glass clean.

This is why it is recommended that the coal control be positioned to the **left** for wood burning.



**CAUTION**

**THE OPERATION RANGE OF THE AIR CONTROLS MAY NOT BE ALTERED FOR ANY REASON.**



**CAUTION**

**ALWAYS WEAR FIRE-RESISTANT GLOVES TO OPERATE THE STOVE. THE AIR CONTROL IS HOT WHILE IN OPERATION.**

## Building and Maintaining a Wood Fire

**Never use gasoline, gasoline-type lantern fuel, kerosene, charcoal lighter fluid, or similar liquids to start or "freshen up" a fire in this heater. Keep all such liquids well away from the heater while it is in use**

Crumple up six to eight sheets of news paper and place in the firebox. Next place pieces of dry wood 3/4 inch maximum diameter on top of the paper, Next place several 1"-2" split pieces of dry wood on top, followed by a few 2"-3" split pieces. Set the wood air controls at the maximum heat output setting, all the way up. Place the knob on the bottom door to the left. These settings will allow the glass to stay clean as you build your fire. The coal knob may be moved to the right to speed the ignition process but the glass may get dirty.

Ignite the paper and allow the fire to burn until a good charcoal bed, 2"- 3" (50 mm - 80 mm) is formed; (You may need to leave the ash door open a crack to get the blaze going properly, but never leave the stove unattended with a door open.) Add more wood to create a deeper charcoal base 3" to 4".

Once the charcoal bed is established you may add a full load of dry wood. After adding the fuel, leave air setting at maximum for 5 to 15 minutes. Then, adjust the air controls and blower speed for the desired heat output.

# Building & Maintaining a Fire

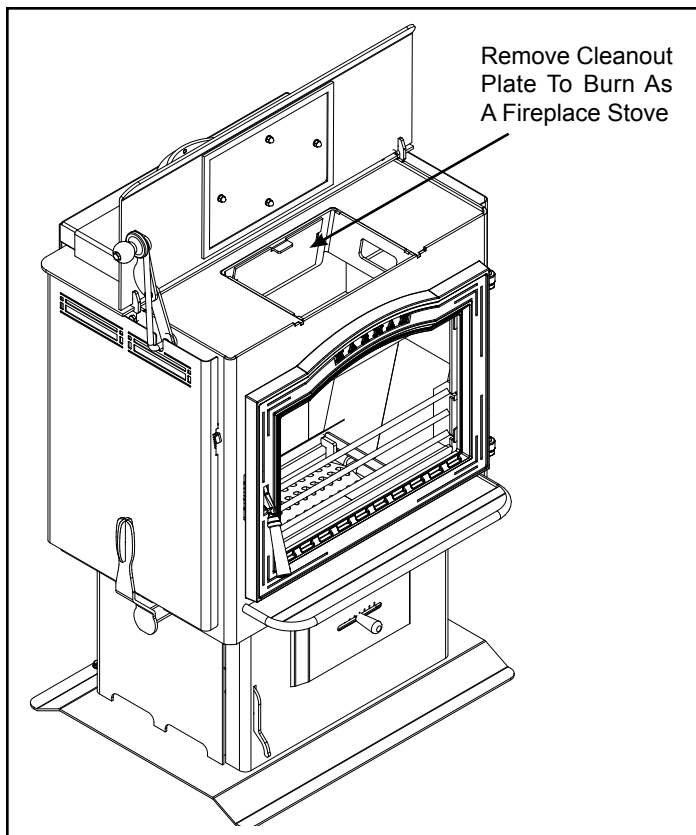

Ashes should be placed in a steel container with a tight fitting lid and moved outdoors immediately. The closed container of ashes should be placed on a noncombustible floor or on the ground, well away from all combustible materials, pending final disposal. If the ashes are disposed of by burial in soil or otherwise locally dispersed, they should be retained in the closed container until all cinders have thoroughly cooled. Other waste shall not be placed in this container.

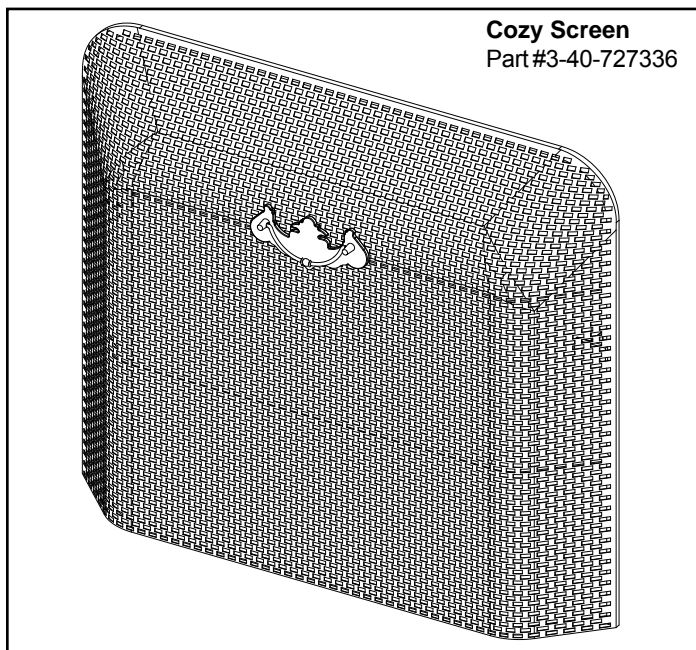

## Reloading

Once you have prepared and maintained a thick charcoal bed, you should be able to reload the stove, allow some burning at the maximum air setting, and reset the air control in a few minutes.

Select hardwoods if possible, as they are heavier and contain more heating capacity (BTU's) per load than do softwoods. Wood should be split and stored under cover for "seasoning" a year is recommended. Your stove is not an incinerator, do not burn garbage, painted or treated wood, plastic, or other debris.

Keep the area around the stove free from clutter. Keep all combustibles, including fuel, beyond the code-required clearance distance (48" or 1215 mm in the U.S., 1525 mm or 60" in Canada). Never store fuel in front of the stove where it could interfere with door operation, safe loading, and ash removal.

**Blower** - To regulate the speed of the optional convection blower, adjust the control from low to high by turning the knob located on the blower cord.

## Removing Wood Ashes

Always wear gloves to remove the ash pan. Lift the latch on the ash door and open. Pull the ash pan out by the handle. Lift the handle to the vertical position to carry the ashes to a disposal location. Close the ash door while you are disposing of the ashes. The fire will get very hot if the bottom door is left open even for a short period. Replace the ash pan. Remove ashes from the fire chamber periodically by shaking the grates. Wood burns best with an ash bed under the wood; therefore, do not shake all of the ashes down. Never let the ashes build up to over 3" in depth. Excessive ash buildup can prevent proper venting of exhaust gases. Also do not overfill the ash pan. Ash buildup between the ash pan and the grates can cause them to overheat and wear out prematurely.

## Operating as a Fireplace

The TLC 2000 is tested and approved to be burned with the front load door open. In this mode of operation you get a true fire sound as well as appearance. Due to the crackling and popping of burning wood it is necessary to place the optional screen over the door opening. This prevents sparks from entering the room just like a screen over a fireplace.

The clean-out plate (see above) should be removed to burn as a fireplace. This is done by lifting up on the tab on the front of the plate.

To install the screen, open the glass door and place the screen over the door opening. Push on the screen until the two spring clips snap into place. To remove the screen, pull on the handle.

# Building & Maintaining a Fire

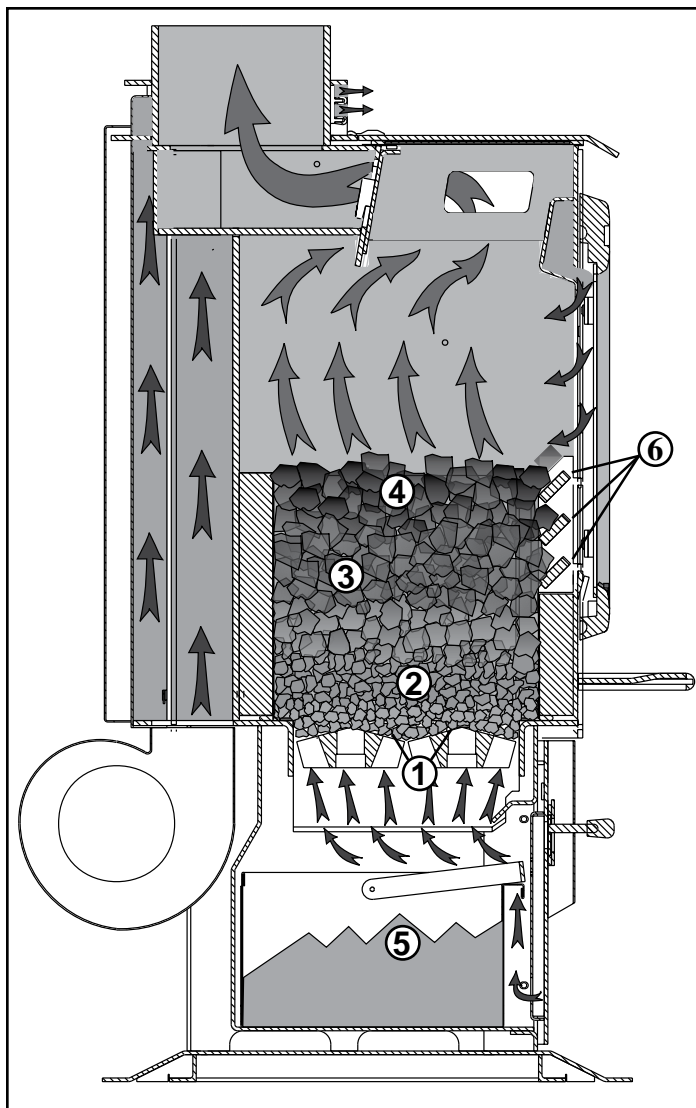

- |                       |                     |
|-----------------------|---------------------|
| 1. Grates             | 4. Fresh Coal       |
| 2. Ashes On Grates    | 5. Ashes in Ash Pan |
| 3. Partly Burned Coal | 6. Grate Bars       |

## Building and Maintaining a Coal Fire;

Build a wood fire as described but instead of adding larger wood, limit the size to about 2" in diameter. Add enough 2" wood that the firebox floor is covered with burning wood.

After the wood is burning well for about five minutes, put the wood air controls in the down position and slide the coal air control to the right. This makes the primary air flow up through the grates as is required for coal burning.

Next add a layer of coal on top of the wood. Continue burning until the layer of coal is turning red and igniting. It is possible to speed this process by opening the ash door, but never for more than five minutes at a time.

Operation with the ash door open for more than five minutes will overfire the stove and may cause damage to the stove. Never leave the stove unattended with the ash door open.

After the layer of coal is burning, a second layer may be added. After the second layer is burning, more layers may be added. **Do not add coal above the firebricks or grate bars.**

**The stove is hot while in operation. Keep children, clothing and furniture away. Contact may cause skin burns.**

As you begin to operate your stove at higher temperatures, you will notice a "hot" or unpleasant smell; this is just the paint going through the curing process, and will disappear after a few fires.

## Overfiring

Avoid overfiring your stove. This is a potentially hazardous situation which can lead to the overheating of combustible wall or floor materials, damage to the stove, and in extreme cases, cause a fire. Overfiring is caused by: Too much air flowing through the stove too quickly. You may have inadvertently left the bottom door open. Or, Not keeping up with routine maintenance, such as checking door gaskets for wear. The chimney may have excessive draw or draft, which can be remedied by installing a barometric damper

Overfiring results in excessive fuel consumption, and may cause parts of the stove or chimney connector to glow red. If you notice signs of overfiring, reduce the air supply to the fire, and review the Maintenance section in this manual. Do not burn the stove continuously at the maximum setting. If maximum heat is required day after day, the stove is too small for the area you are trying to heat.

**Never leave the stove unattended if either the ash or load door is open. Overfiring may result.**

In the event of a chimney fire, call your local fire department; make sure everyone is safely out of the house. Reduce the air intake of the stove as much as possible using the air control lever. Do not throw water on the fire; this can cause stove damage and create an even more dangerous situation. Have your chimney professionally cleaned and inspected before resuming burning in your stove.

# Building & Maintaining a Fire

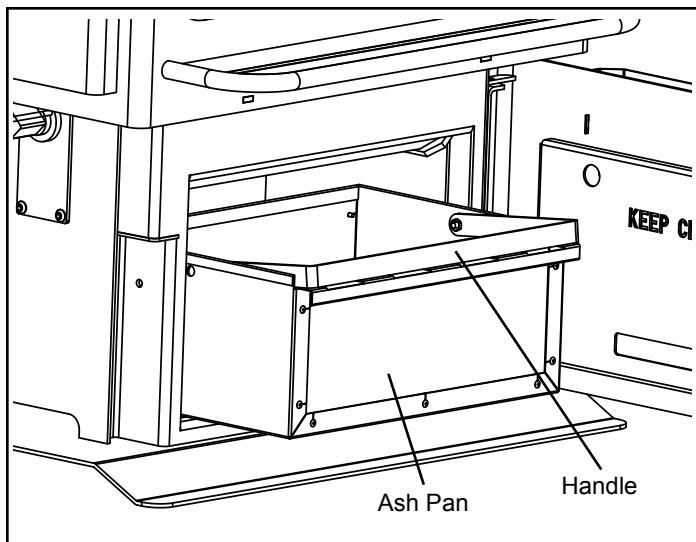

**Disposal of Ashes.** The TLC 2000 was designed to provide access to the ash pan without the need for opening the main door. Wearing heavy protective gloves, open the ash door and remove the ash pan by pulling it forward by the handle. Close the ash door before taking the ashes outside for safe disposal.

A good time to empty the ash pan is before loading. This ensures that the ashes will be cold and safer to handle than directly after shaking the ashes down or tending the fire.

**Ashes should be placed in a steel container with a tight fitting lid and moved outdoors immediately. The closed container of ashes should be placed on a noncombustible floor or on the ground, well away from all combustible materials, pending final disposal. If the ashes are disposed of by burial in soil or otherwise locally dispersed, they should be retained in the closed container until all cinders have thoroughly cooled. Other waste shall not be placed in this container.**

## Refueling

Open the coal air control to the maximum position by sliding it to the right. Allow the fire to burn vigorously for several minutes. Shake the grates with short choppy strokes until the first red coals fall into the ash pan, then stop! Add coal to the top of the coal bed. It is good to allow some red hot coals exposed to help ignite the gases coming off of the newly added coal. These gases can be volatile if left to accumulate. The coal air control may be returned to the desired setting.

## Stainless Steel Cooking Grill (Optional)

The cooking grill can be used for open fire grilling over anthracite coal or wood.

To install the grill, place the handle in the grill as shown at left. The grill can now be lifted and positioned in the opening on top of the stove as shown below left.

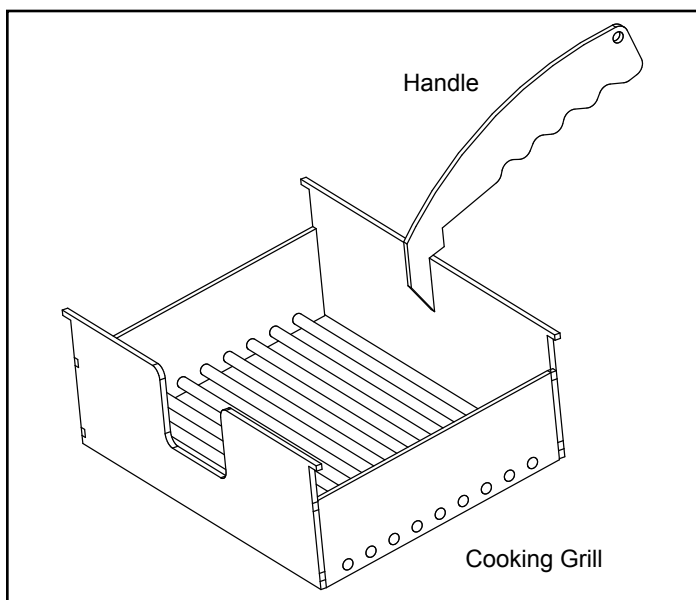

**COOKING GRILL MAY BE HOT.** Always wear gloves when handling the cooking grill.

Cooking on anthracite coal produces flavor similar to a gas grill.

Cooking on wood produces many flavors depending on the type of wood used. More flavor is added when cooking is done with the top closed. This causes the heat and smoke to circle around the food.

As with grilling or any open fire cooking, the amount of heat and cooking time must be experimented with for best results.

# Maintenance

Like all fine equipment, your TLC 2000 requires some routine maintenance and inspection. Follow the guidelines in this section to guarantee safe, efficient operation.

## The Stove

### Surface

The stove's exterior surface should be dusted periodically with a soft cloth. For more thorough cleaning, wait until the stove is cool before using a damp cloth to clean any blemishes.

### Controls

To avoid a rust build-up on the inner surfaces of the controls, work the controls back and forth several times, during the summer, or any prolonged period when you are not using your stove.

### The Fire Chamber

The inside of the fire chamber should be examined for damage to the firebrick lining material, and grates. If any bricks have been damaged, replace them with Harman replacement parts.

### Venting System / Chimney

**Creosote - Formation and the need for removal-** When wood is burned slowly, it produces tar and other organic vapors, which combine with expelled moisture to form creosote. The creosote vapors condense in a cool chimney of a slow burning fire. As a result, creosote residue accumulates in the flue lining. When ignited, this creosote makes an extremely hot fire. The chimney connector and chimney must be inspected at least once every two months during the heating season to determine if a creosote build-up has occurred. If a significant layer of creosote has accumulated (3mm or more), it must be removed to reduce the risk of a chimney fire.

In the event of a chimney fire, call your local fire department; make sure everyone is safely out of the house. Reduce the air intake of the stove as much as possible using the air control lever. Do not throw water on the fire; this can cause stove damage and create an even more dangerous situation. Have your chimney professionally cleaned and inspected before resuming burning in your stove.

### Glass - Replacement

The glass in this unit is a ceramic glass. 5mm X 444mm X 311 mm. available from your Legacy Stoves dealer.

If the stove's glass is cracked or broken, you must replace it before operating your stove. Remove pieces carefully. Replace glass only with Legacy supplied replacement glass panels; do not use substitutes.

To replace the glass panel, you will need to remove the door. To do this, open the door, lift it straight up and place it on a soft surface.

Carefully remove damaged glass, gasket material, and hold down clips (set aside).

Referring to the diagram, note how the various components of the door system fit together. Lay the load door face down on the soft surface, and install the self adhesive 1/4" gasket material around the front face of the glass.

Set the glass pane and gasket gently onto the door. Install the hold down clips and tighten with bolts as shown. Reinstall door on stove.

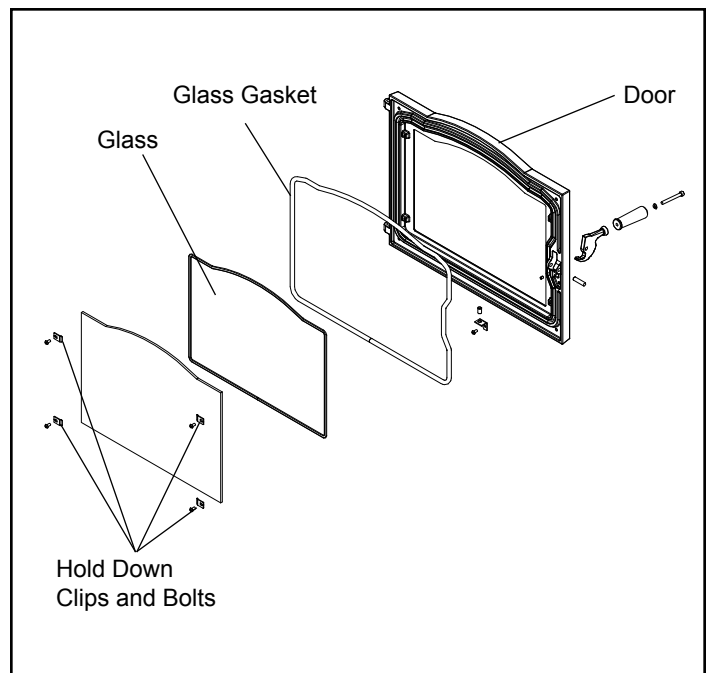

# Maintenance

## Glass - Cleaning

Sometimes it will be necessary to clean accumulated ash from the glass surface; allowing this ash to remain on the glass for long periods can result in “etching” due to the acidity of the ash. The creosote which accumulates on the glass should burn off during your hot fires.

Never clean the glass while it is hot, and do *not* use abrasive substances. Wash the surface with cool water, and rinse thoroughly. You may wish to use a non-abrasive cleaner specifically designed for use on stove glass. In any case, dry thoroughly before relighting your stove.

## Gaskets

Gaskets are used on the doors and top lid of the TLC 2000. You must check these gaskets from time to time, and replace them when necessary. The gaskets are made of fiberglass of different sizes (obtainable from Legacy Dealer) and are fixed in place with a high temperature stove gasket cement. To change a gasket, first remove the worn fiberglass and clean the area with a wire brush. Also clean any other surfaces that come into contact with the gasket. Place a small bead of cement in the area under the gasket, then press new gasket material into the channel; do not overlap the ends. Seat the gasket firmly by applying pressure when possible; for example, after changing the door gasket, close the door. Allow the cement to dry before using your stove.

### Gaskets are located:

On the doors to provide airtight closure.

On the lid.

## Blower

The optional blower on your TLC 2000 stove requires very little maintenance. You should, however, keep the air inlet and the motor free of dust and dirt.

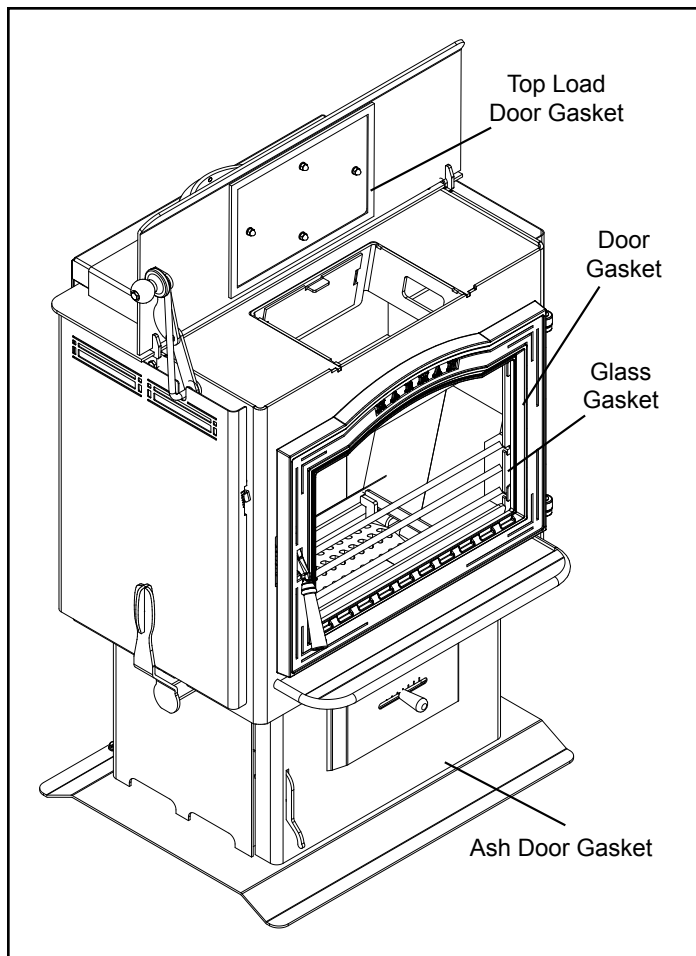

# Installation

## DO NOT INSTALL IN A SLEEPING ROOM

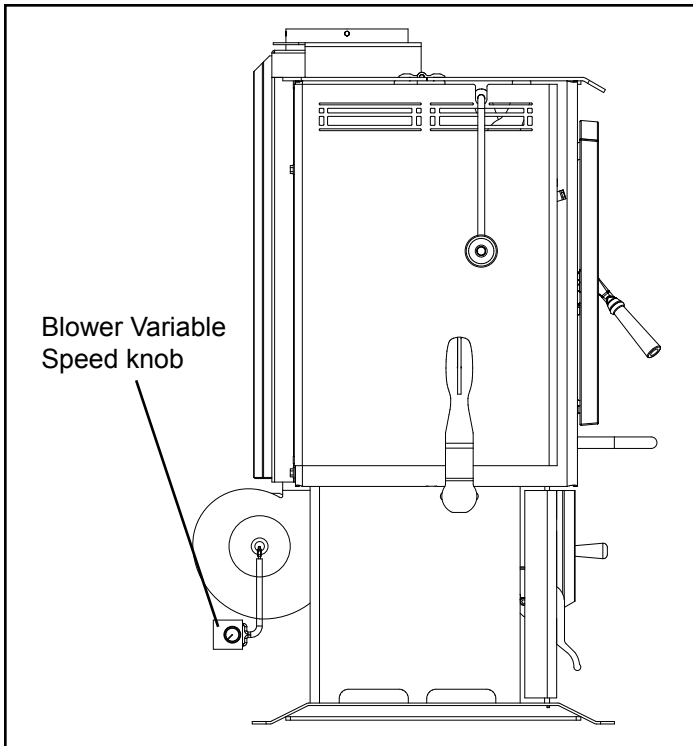

### Assembly

#### Blower (Optional)

Bolt the blower to the bottom rear of the stove with four 1/4-20 bolts. Tighten the bolts, but do not overtighten.

The blower speed can be adjusted using the knob that is built-in to the power cord. When first starting a fire, keep the blower off. After a good bed of coals is established, you can run the blower at any speed desired.

The power cord for the blower must be connected to a grounded outlet, and must be routed away from the appliance.

#### Top Air Grill (Optional)

The top air grill must be installed before the chimney connector is installed.

To install simply place the top air grill over the flue out let and position as shown at left. It is held in place by gravity.

The top air grill is a decorative option that does not add or subtract from the performance of the stove.

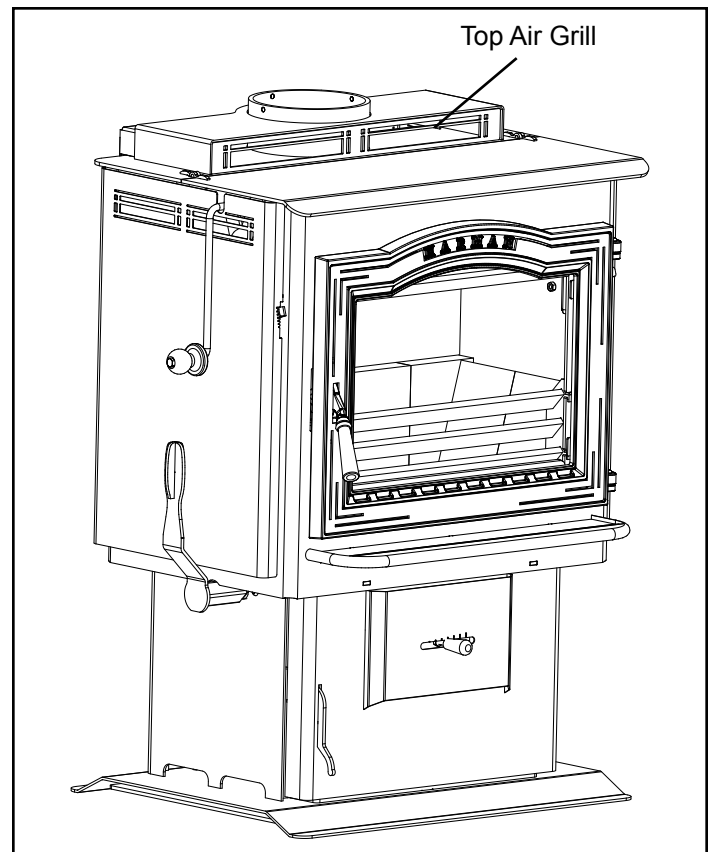

# Installation

## Floor Protection

In all installations, the area under and around the stove must be protected from falling ash and live coals. The floor protector must be of noncombustible material, and positioned as shown in the accompanying illustration.

### The guidelines for floor protection are:

1. Completely under the stove and any horizontal runs of connector. The floor protection must extend a minimum of 2" (51 mm) beyond each side of the horizontal connector;
2. 8" (203 mm) to each side and to the rear of the appliance;
3. 16" (405 mm) in front of the doors (U.S.); 18" (457 mm) in front of the doors (Canada).

## Clearances

Clearance is the empty space required between the stove or chimney connector to the nearest combustible surface or object, such as walls, ceilings, floors, or furniture. Clearance distances may only be reduced by using methods approved by either the CAN/CSA B365 standard (Canada) or NFPA 211 (U.S.) Contact your building authority for information if you are interested in reducing clearance distances other than those presented here.

Floor Protection Requirements		Inches	Millimeters
<b>G</b>	Sides- USA /CANADA *	8	203
<b>H</b>	Front- USA /CANADA *	16	457
<b>J</b>	Rear- USA	8	203

Parallel Installation		Inches	Millimeters
<b>A</b>	Back Wall To Unit	16	406
<b>B</b>	Side Wall To Unit	18	457
<b>C</b>	Back Wall To Flue Connector	18	457

## Parallel versus Corner Installations

A parallel installation is one in which the back and sides of the stove are parallel to the walls behind and to the side of the stove. A corner installation is one in which the back of the stove is positioned diagonally across a corner of the room. Each installation requires its own set of clearances.

For parallel installations the required clearance distances from the stove are: 18" (457mm) to the side wall and 16" (405mm) to the back wall. From the chimney connector to the rear wall must be 18" (457mm), to the side wall 27" (685mm) and to the ceiling, 36" (914mm). Fireplace installations must meet these same clearance requirements; specifically follow these guidelines for mantel and trim clearances.

For corner installations, the clearance distances from the stove are 12" (305mm) from each corner of the stove measured straight to the nearest combustible material. When the unit is placed 12 inches from the wall, the measurement of the Wall to Flue Connector will be 21 inches. Note that this is larger than the required minimum clearance of 18 inches.

From the front of the stove, clearance to combustible materials such as furniture, curtains, fuel, etc., is: 48" (1219mm) in the U.S. and 60" (1524mm) in Canada.

**Alternate floor protector dimension may be used as long as they satisfy the measurement requirements shown below.**

**Minimum size floor protection for a corner installation hearth pad is 48" x 48" (USA ONLY).**

Corner Installation		Inches	Millimeters
<b>E</b>	Walls to Unit Body	12	305
<b>F</b>	Walls to Flue Connector	18	457

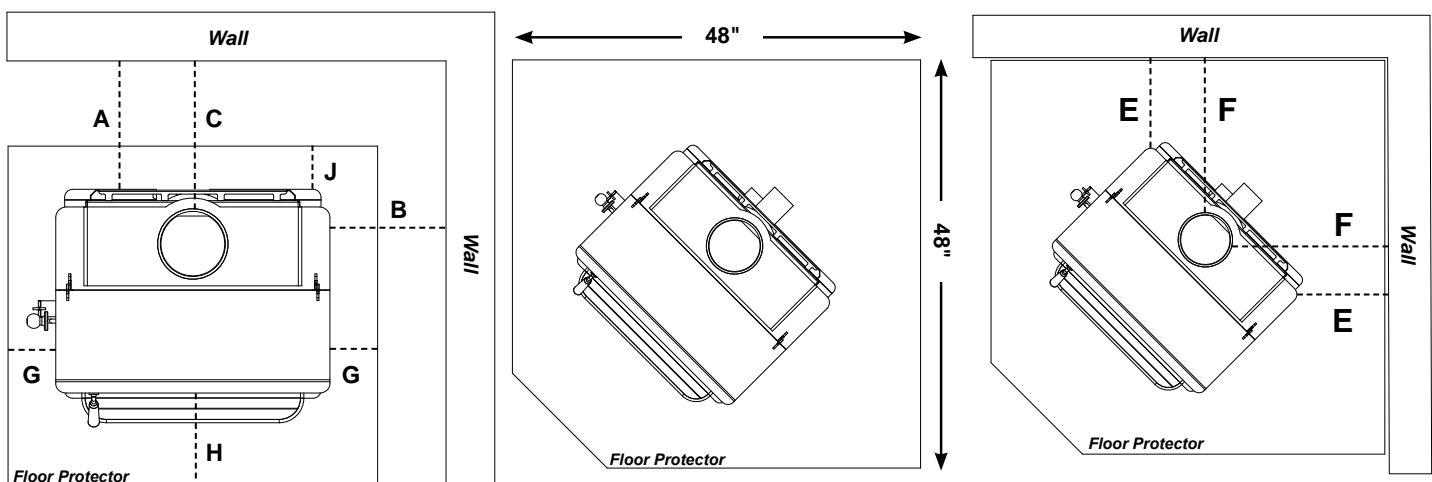



# Chimney System

## The Chimney System

### Soot and Creosote - Formation and Need for Removal

When wood is burned slowly, it produces tar and other organic vapors, which combine with expelled moisture to form soot or creosote. The soot and creosote vapors condense in the relatively cool chimney flue of a slow burning fire. As a result, soot or creosote residue accumulates on the flue lining. When ignited, this soot or creosote can result in an extremely hot fire.

The chimney connector and chimney should be inspected at least once every two months during the heating season to determine if a soot or creosote build-up has occurred. If soot or creosote has accumulated (3 mm or more) it should be removed to reduce the risk of a chimney fire.

Checking your chimney and chimney connector more frequently, especially while you are getting used to your stove, is recommended. To inspect this system, let the stove cool. Using a flashlight and mirror, check the interior of the chimney connector, and the chimney itself.

To clean deposits from the surface of the connector, use a stiff wire brush after dismantling the connector assembly. To clean the chimney, use a specially designed brush sized to fit your particular flue opening, or call an established chimney cleaning service.

At the end of the heating season, perform a thorough examination of your chimney system, and have it repaired if necessary.

### Draft

Draft is widely misunderstood. It is important that you, the stove operator, realize that draft is a variable *effect*, not a given quantity. Stoves and chimneys do not *have* draft, yet draft is the key to your stove's performance.

Draft is a *force*, produced by an operating stove and the chimney to which it is attached. It is created by hot gases rising up the chimney, creating a pressure difference between the inside of your home and the outside air. It continually moves fresh combustion air into the stove, and hot exhaust gases out of the stove; without this constant flow, the fire will go out.

Other factors, such as barometric pressure, winds, the airtightness of the home, the total inside chimney volume, chimney height and the presence of venting devices such as exhaust fans also play a role in maintaining an adequate draft. In some cases, a window may need to be left open, or some other source of fresh air provided, to keep the appliance operating properly. Low barometric pressures, super insulated homes and exhaust fans can reduce draft; winds can play havoc with draft; and too large or too small a chimney volume can cause reduced draft due to the excessive cooling or not enough room to vent exhaust gases quickly.

Some signs of inadequate draft are smoking, odor, difficulty in maintaining the fire, and low heat output. Overdraft can be caused by a very tall chimney even if it is the recommended size, and can cause overfiring of your stove. Signs of an overdraft include rapid fuel consumption, inability to slow the fire, and parts of the stove or chimney connector glowing red. It is important that you follow the chimney guidelines in this manual, including size, type, and height to avoid draft problems.

When installed and operated according to this manual, the TLC 2000 will produce enough hot gases to keep the chimney warm so that adequate draft is maintained throughout the burn cycle.

### Chimney Connectors

In general, following these guidelines will ensure compliance with all national and provincial codes; prior to beginning your installation, check with your local building code official to check on additional local regulations which may influence the design and placement of your venting system.

The Legacy TLC 2000 may be installed with 24 (150mm) gauge chimney connector pipe. Size of the connector should correspond to the size of the flue collar opening. Do not use makeshift compromises. **No part of the chimney connector may pass through an attic or roof space, closet or other concealed space, or through a floor or ceiling.** Whenever possible, avoid passing the connector through a combustible wall; if you must, use an approved wall pass-through, described later in this section.

Assemble the connector beginning at the flue collar, with the crimped ends pointing towards the stove (to keep debris and creosote flakes inside the system). Each joint, including the one to the stove's flue collar and the one to the chimney itself should be secured with at least three sheet metal screws. Screws may be a maximum of 3 inches apart. A 1-1/4" (30 mm) overlap is required at each joint, including the flue collar attachment. No more than two 90 degree elbows should be used, and the total length of connector should not exceed 10 feet (3 m). All horizontal runs of connector must have a minimum upward slope of 1/4"(6 mm) per foot (20 mm per meter).

### Wall Pass-throughs

Occasionally it is necessary to pass the chimney connector through a combustible wall to reach the chimney. Depending on your local building codes, and the pertinent provincial or national codes, there are several choices for accomplishing this safely. Before beginning your installation, contact local officials, and also the chimney connector and chimney manufacturer for specific requirements.

**Canada:** Three methods are approved by the Canadian Standards Association. The diagram shows one method requiring an 18" (450mm) air space between the connector and the wall. It allows use of one or two covers as described in the diagram. The two other methods are described in detail in the current issue of CAN/CSA B365, the national standard.

**United States:** In the U.S., the national code is NFPA 211. While many localities adopt this standard, be sure to check with local authorities before beginning your installation.

# Chimney System

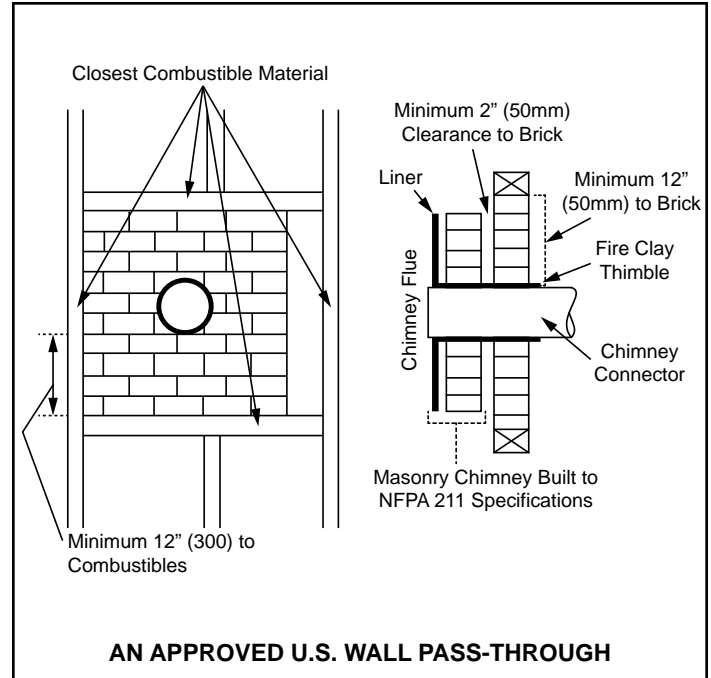
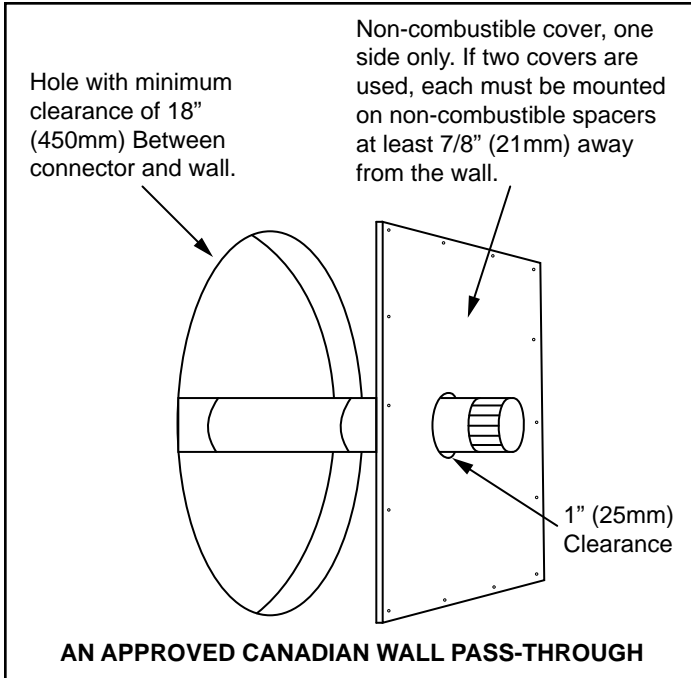

The NFPA (National Fire Protection Association) permits four methods for passing through a combustible wall. A commonly used method to pass through a wall directly to a masonry chimney is to clear a minimum 12" (300 mm) around the entire chimney connector, and fill it with brick masonry which is at least 3.5" (90 mm) thick. A fireclay liner, minimum 3/8" (9 mm) wall thickness must run through the brick wall to the chimney liner (but not beyond the inner surface of the liner). It must be cemented in place with refractory cement. This method is illustrated. For details on the other three options, refer to the most recent edition of the NFPA 211 code.

## The Chimney

The TLC 2000 must be installed into a chimney approved for use with solid-fuel appliances. In the U.S., the TLC 2000 must be connected to (1) a prefabricated chimney complying with the requirements for Type HT chimneys in the Standard for Chimneys, Factory-Built, Residential Type and Building Heating Appliances, UL 103, or (2) a code-approved masonry chimney with a flue liner. In Canada, the TLC 2000 is listed for use with prefabricated chimneys tested and listed to the high temperature (650 degrees C) chimney standard, ULC S-629, or with a code approved masonry chimney.

The minimum recommended height for any chimney is 16 ft (4.8 m) above flue collar height. A round flue (either masonry or approved prefabricated), of either 6" (150 mm), 7" (180 mm) or 8" (200 mm) may be used. For square or rectangular masonry chimneys, nominal sizes of 8" x 8" or 8" x 12" (200 mm x 200 mm, 200 mm x 300 mm) may be used.

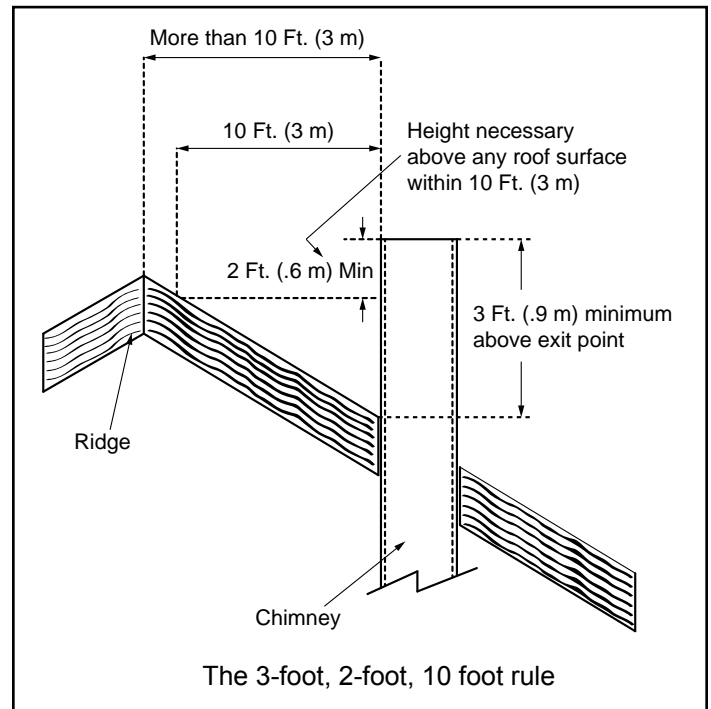

Codes require that solid-fuel chimneys extend 3 ft (0.9 m) above the point at which they exit from the roof, provided that no part of any structure is within the top of the chimney, then the chimney must extend 2 ft (6 m) above the highest point with the 10 ft (3 m) radius top height. If there is not ten feet of clearance from the top of the chimney, then the chimney must extend 2 ft (6 m) above the highest point with the 10 ft (3 m) radius.

# Chimney System

**DO NOT CONNECT THIS UNIT TO A CHIMNEY FLUE SERVING ANOTHER APPLIANCE.**

## Existing Masonry Chimneys

If you plan on using a pre-existing masonry chimney, have it thoroughly inspected and cleaned. Any faults which make the chimney unsafe and unusable must be repaired prior to use. These can include improper height, structural defects, blockages, inadequate clearance to combustibles, unsealed openings into other rooms of the house, signs of creosote or smoke leakage, a loose or absent clean-out door, or absence of a liner.

**DO NOT CONNECT TO ANY AIR DISTRIBUTION DUCT OR SYSTEM**

## Venting to a Masonry Chimney

When connecting to a masonry chimney, several provisions are standard. First, whether the chimney connector is vented to the chimney through a thimble or a breech pipe, neither must pass beyond the inner surface of the chimney liner, and both must be firmly cemented in place with refractory cement. (A thimble is a masonry pipe which is inserted through the chimney wall, and is frequently the preferred method; a breech pipe is a piece of steel pipe used the same way.) In Canada, a breech pipe has ridges or protrusions to lock it firmly into the refractory cement. In either case, the chimney connector vents to the chimney through the thimble or breech pipe.

Using a thimble, the connector slides completely inside the masonry to the inner edge of the flue liner, and may be easily removed for chimney and connector inspection. A breech pipe must extend at least 2" (50 mm) into the room, so the connector can be attached with sheet metal screws.

## Venting to a Masonry Fireplace Chimney

In some situations, a code compliant chimney originally used for a masonry fireplace may be used to install your TLC 2000. In addition to the requirements found in the previous paragraphs, it is important to be aware that all clearances must be met, including those from the chimney connector to combustibles — 18" (360 mm) to sides and 18" (450 mm) to ceiling. Do not forget to include floor protection in your plans. (See Clearances and Floor Protection in this section.) Since many fireplaces have exposed wooden mantels and trim, pay special attention to the clearances necessary to these materials.

If your fireplace chimney is behind a combustible wall, you must use an approved wall pass-through system to gain access to the masonry chimney. The chimney connector must enter the chimney at a place where it is lined, and the fireplace must be made inoperable. For example, you might remove the damper, replacing it with a secure, airtight, noncombustible seal (removable for inspection); this also satisfies the requirement that no room air must be allowed to enter the chimney.

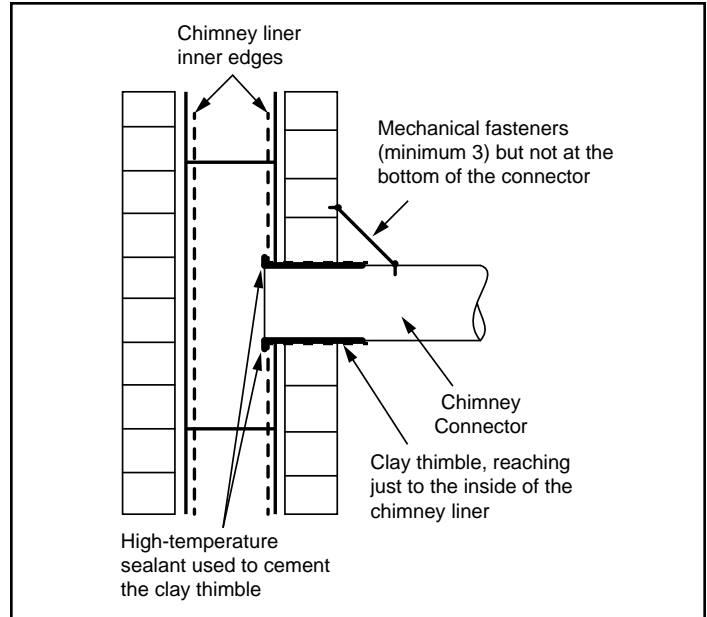

## Installing to a Prefabricated Chimney

When venting your TLC 2000 using a prefabricated chimney, be sure to contact local building code authorities, and to follow the manufacturer's instructions *exactly*. Use only the manufacturer's parts; do not use makeshift installation techniques. All prefabricated chimneys must be tested to either the U.S. or Canadian high-temperature standards, UL 103 or ULC-629.



**WARNING**

**DO NOT INSTALL IN SLEEPING ROOM.**

The Legacy TLC 2000 was tested with the fuel door open and closed.

If you operate with the door open, be sure to install the optional fire screen, and be sure the cleanout cover above the firebox is removed.

Do not burn any fuel other than those specified. Other solid fuels, such as charcoal, can cause increased carbon monoxide production or overfiring. Never use highly volatile substances in your stove, such as gasoline, which could cause an explosion.

When solid fuels are burned completely, they produce water and carbon dioxide. However, in long slow burns, a substantial amount of carbon monoxide may be produced. If allowed to build up, carbon monoxide (which is odorless) can prove fatally poisonous. Proper ventilation and draft will prevent this from happening. If you smell smoke, turn up the air control lever setting, and thoroughly ventilate your dwelling. During future burns, be careful not to overload the stove with fuel, so you will not be tempted to constantly operate at a low air control setting.

Other causes of poor ventilation or draft are icing, exhaust fans, a blocked outside air inlet, and room air starvation. If your stove is sluggish and you get occasional odor, check these possibilities and increase the air flow in your home.

### Retired Units

1-70-08690-4 (Metallic Blue) Ending Manufacturing Date Jan 2010  
1-70-08690-5 (Honey Glo) Ending Manufacturing Date June 2009  
1-70-08690-10 (Mojave Red) Ending Manufacturing Date Jan 2010  
1-70-08690-12 (Forest Green) Ending Manufacturing Date Jan 2010

1-70-08690-1 (Black) Ending Manufacturing Date: June 2011  
1-70-08690-2 (Charcoal) Ending Manufacturing Date: June 2011  
1-70-08690-3 (Goldenfire) Ending Manufacturing Date: June 2011

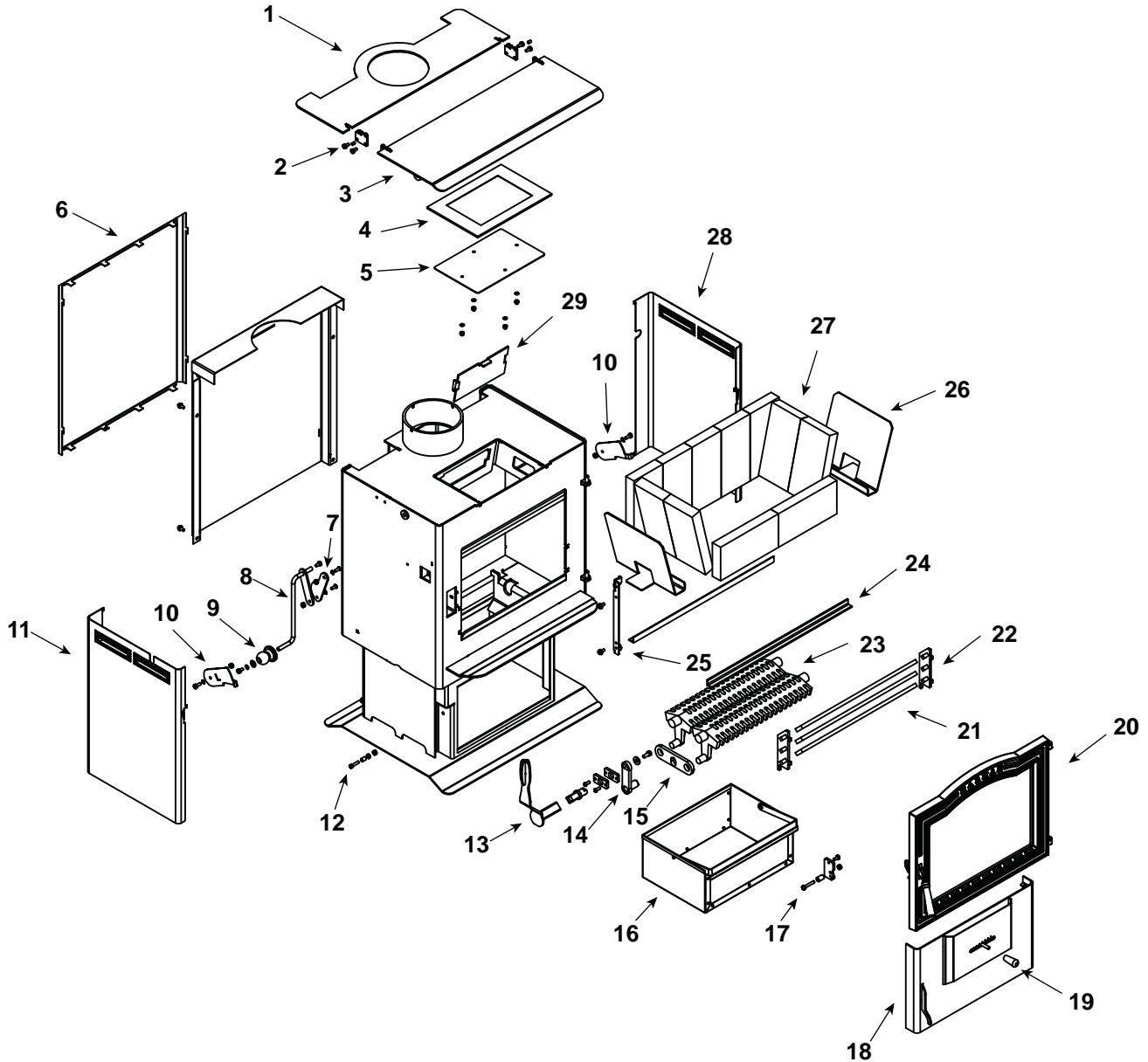

Part number list on following page.



Service Parts

TLC-2000

Beginning Manufacturing Date: N/A  
Ending Manufacturing Date: Active

IMPORTANT: THIS IS DATED INFORMATION. Parts must be ordered from a dealer or distributor. Provide model number and serial number when requesting service parts from your dealer or distributor.



Stocked at Depot

ITEM	DESCRIPTION	COMMENTS	PART NUMBER	
1	Top, Rear		2-00-852109L	
2	Hinge, Rear	Qty 2 req	2-00-852129L	
3	Top Load Door Assembly		1-10-08720A	
4	Gasket, Bulb black 1-1/2" X 9-32 w/psa (top plate)	3 1/2 Ft	1-00-10025	Y
5	Gasket Plate w/gasket		1-10-08759A	
6	Heat Shield		2-00-852160B	
7	Top Lift Arm		2-00-852128P	
8	Damper Linkage Arm Weldment w/Knob		1-10-08722	Y
9	Wooden Knob (damper handle), 2 Sets	Pre 008850439	1-00-05228	Y
	Wooden Knob w/Bolt, 2 Sets	Post 008850439	1-00-06228	
10	Air Adjuster, Left and Right	1 Set	1-00-852140	
11	Shield, left side	Pre 008860387	2-00-852139P	Y
		Post 008860387	2-00-852181P	Y
12	Ash Door Latch Hardware		1-00-85223	Y
13	Shaker handle weldment		1-10-852166	Y
14	Shaker Bar Weldment		1-10-08717	Y
	Shaker Replacement Kit w/Bushings	Pre 008860016	1-00-852016	Y
		Post 008860016	1-00-852172	
15	Grate link		2-00-852119	Y
16	Ash Pan		1-10-08690	Y
17	Load Door Latch w/Hardware		1-00-06903	
18	Ash Door Assembly		1-10-08718A	
	Gasket, Round white Id 5/8" (ash door)		1-00-10000	Y
19	Airslide Knob	Pkg of 3	3-40-08746-3	
20	Door Kit Assembly	No longer available	1-00-08711-1	
	Door Assembly	Post 008860387	1-10-02748A	Y
	Cast Latch		3-00-249119P	Y
	Door Frame - Roped	Pre 008860387	1-10-08159A	
	Gasket, Glass	15 Ft	1-00-2312	Y
	Gasket Glue, 32 oz		3-42-4583	
	Gasket, Door	Pre 008860387	1-00-00888	Y
		Post 008860387	1-00-1086204	Y
	Glass Clips and Screws		2-00-05202-4	Y
	Glass Rect 12-7/16" X 17-5/8"	Pre 008860387	3-40-08214	Y
	Glass Rect 12.4" X 16.6"	Post 008860387	3-40-02749	Y
	Load Door Handle & Hardware	Pre 008860001	1-00-08176	Y
21	Coal Bars	Set of 3	1-00-852145	
22	Coal Bar Holders	Set of 2	1-00-852146	

Additional service part numbers appear on following page.



## Service Parts

# TLC-2000

Beginning Manufacturing Date: N/A  
Ending Manufacturing Date: Active

IMPORTANT: THIS IS DATED INFORMATION. Parts must be ordered from a dealer or distributor. Provide model number and serial number when requesting service parts from your dealer or distributor.



**Stocked  
at Depot**

ITEM	DESCRIPTION	COMMENTS	PART NUMBER	
23	Grate, long 15 in - cast	Qty 2 req	3-00-00208	Y
24	Brick Supports	1 Set	1-00-0872456	
25	Bolt (ash door hinge)		2-00-06952B	
26	Brick Backer	Qty 2 req	2-00-852147	Y
27	Brick 9" X 4-1/2" x 1-1/4"	Pkg of 7	1-00-900450125	Y
	Brick, Full skid	414 Pcs	3-40-900450-414	
28	Shield, right side	Pre 008860387	2-00-852141P	Y
		Post 008860387	2-00-852182P	Y
29	Cleanout, TLC		2-00-852153	Y
	Ash Lip Trim	Gold	3-43-4722386	
		Brushed Stainless	3-43-4722386-7	
	Air Grill Trim	Pre 008860387	3-43-08725	
	Blower option - includes 3 speed control		1-00-08643	Y
	Brass Elbow		3-40-00121	
	Bronze Bushing	Post 008860016	3-31-852177	
	Bushing, Steel Sleeve, 3/8 OD x 1/2 OAL		3-50-05229	
	Cast Pawl		3-00-453002	Y
	Door Trim	Post 008860387	3-43-856015-7	
	Dowel pin 1/4 X 3/8	Pkg of 15	3-30-2019-15	
	Handle, Cooking Grill		2-00-852169L	
	Load Door Handle w/Bolt		1-00-00247	Y
	Paw Bolt (old style)		4-31-08055	Y
	Pawl Retrofit		1-00-453001	Y
	Power Cord		3-20-29685	Y
	Screw, #10-24 x 3/8" Alloy Steel Black Oxide Button Head Cap	Pkg of 100	3-30-3011-100	Y
	Screw, 1/4"-20 x 2 1/2" Phillips Round Head Zinc Pltd Machine	Pkg of 25	3-30-6007-25	Y
	Shaker Shaft		3-50-03373	Y
	Spring Washer - plated 6mm	Pkg of 25	3-31-08558-25	
	Top Air Grill Assembly (Option)	Pre 008860387	1-00-08710	
		Post 008860387	1-00-856001-7	
	Touch Up Paint, Aerosol	Pre 008860308	3-42-1990	
		Post 008860308	3-42-19905	
	Variable Speed Control w/off		3-20-02223	
	Wooden Handle, Front Door w/Hardware		1-00-00122	Y
	Wooden Handle, Load Door, Only		3-40-00247	Y

## Alternate Heating Systems LIMITED LIFETIME WARRANTY

Alternate Heating Systems, on behalf of its hearth brands ("AHS"), extends the following warranty for AHS gas, wood, pellet, coal and electric hearth appliances that are purchased from an AHS authorized dealer.

### **WARRANTY COVERAGE:**

AHS warrants to the original owner of the AHS appliance at the site of installation, and to any transferee taking ownership of the appliance at the site of installation within two years following the date of original purchase, that the AHS appliance will be free from defects in materials and workmanship at the time of manufacture. After installation, if covered components manufactured by AHS are found to be defective in materials or workmanship during the applicable warranty period, AHS will, at its option, repair or replace the covered components. AHS, at its own discretion, may fully discharge all of its obligations under such warranties by replacing the product itself or refunding the verified purchase price of the product itself. The maximum amount recoverable under this warranty is limited to the purchase price of the product. This warranty is subject to conditions, exclusions and limitations as described below.

### **WARRANTY PERIOD:**

Warranty coverage begins on the date of original purchase. In the case of new home construction, warranty coverage begins on the date of first occupancy of the dwelling or six months after the sale of the product by an independent, authorized AHS dealer/ distributor, whichever occurs earlier. The warranty shall commence no later than 24 months following the date of product shipment from AHS, regardless of the installation or occupancy date. The warranty period for parts and labor for covered components is produced in the following table.

The term "Limited Lifetime" in the table below is defined as: 20 years from the beginning date of warranty coverage for gas appliances, and 10 years from the beginning date of warranty coverage for wood, pellet, and coal appliances. These time periods reflect the minimum expected useful lives of the designated components under normal operating conditions.

Warranty Period		AHS Manufactured Appliances and Venting							Components Covered
Parts	Labor	Gas	Wood	Pellet	EPA Wood	Coal	Electric	Venting	
1 Year		X	X	X	X	X	X	X	All parts and material except as covered by Conditions, Exclusions, and Limitations listed
2 years				X	X	X			Igniters, electronic components, and glass
		X	X	X	X	X			Factory-installed blowers
			X						Molded refractory panels
3 years				X					Firepots and burnpots
5 years	1 year			X	X				Castings and baffles
7 years	3 years		X	X	X				Manifold tubes, AHS chimney and termination
10 years	1 year	X							Burners, logs and refractory
Limited Lifetime	3 years	X	X	X	X	X			Firebox and heat exchanger
90 Days		X	X	X	X	X	X	X	All replacement parts beyond warranty period

See conditions, exclusions, and limitations on next page.

## **WARRANTY CONDITIONS:**

- This warranty only covers AHS appliances that are purchased through an AHS authorized dealer or distributor. A list of AHS authorized dealers is available on the AHS branded websites.
- This warranty is only valid while the AHS appliance remains at the site of original installation.
- This warranty is only valid in the country in which the AHS authorized dealer or distributor that sold the appliance resides.
- Contact your installing dealer for warranty service. If the installing dealer is unable to provide necessary parts, contact the nearest AHS authorized dealer or supplier. Additional service fees may apply if you are seeking warranty service from a dealer other than the dealer from whom you originally purchased the product.
- Check with your dealer in advance for any costs to you when arranging a warranty call. Travel and shipping charges for parts are not covered by this warranty.

## **WARRANTY EXCLUSIONS:**

This warranty does not cover the following:

- Changes in surface finishes as a result of normal use. As a heating appliance, some changes in color of interior and exterior surface finishes may occur. This is not a flaw and is not covered under warranty.
- Damage to printed, plated, or enameled surfaces caused by fingerprints, accidents, misuse, scratches, melted items, or other external sources and residues left on the plated surfaces from the use of abrasive cleaners or polishes.
- Repair or replacement of parts that are subject to normal wear and tear during the warranty period. These parts include: paint, wood, pellet and coal gaskets, firebricks, grates, flame guides, batteries and the discoloration of glass.
- Minor expansion, contraction, or movement of certain parts causing noise. These conditions are normal and complaints related to this noise are not covered by this warranty.
- Damages resulting from: (1) failure to install, operate, or maintain the appliance in accordance with the installation instructions, operating instructions, and listing agent identification label furnished with the appliance; (2) failure to install the appliance in accordance with local building codes; (3) shipping or improper handling; (4) improper operation, abuse, misuse, continued operation with damaged, corroded or failed components, accident, or improperly/ incorrectly performed repairs; (5) environmental conditions, inadequate ventilation, negative pressure, or drafting caused by tightly sealed constructions, insufficient make-up air supply, or handling devices such as exhaust fans or forced air furnaces or other such causes; (6) use of fuels other than those specified in the operating instructions; (7) installation or use of components not supplied with the appliance or any other components not expressly authorized and approved by AHS; (8) modification of the appliance not expressly authorized and approved by AHS in writing; and/or (9) interruptions or fluctuations of electrical power supply to the appliance.
- Non-AHS venting components, hearth components or other accessories used in conjunction with the appliance.
- Any part of a pre-existing fireplace system in which an insert or a decorative gas appliance is installed.
- AHS's obligation under this warranty does not extend to the appliance's capability to heat the desired space. Information is provided to assist the consumer and the dealer in selecting the proper appliance for the application. Consideration must be given to appliance location and configuration, environmental conditions, insulation and air tightness of the structure.

## **This warranty is void if:**

- The appliance has been over-fired or operated in atmospheres contaminated by chlorine, fluorine, or other damaging chemicals. Over-firing can be identified by, but not limited to, warped plates or tubes, rust colored cast iron, bubbling, cracking and discoloration of steel or enamel finishes.
- The appliance is subjected to prolonged periods of dampness or condensation.
- There is any damage to the appliance or other components due to water or weather damage which is the result of, but not limited to, improper chimney or venting installation.

## **LIMITATIONS OF LIABILITY:**

- The owner's exclusive remedy and AHS's sole obligation under this warranty, under any other warranty, express or implied, or in contract, tort or otherwise, shall be limited to replacement, repair, or refund, as specified above. In no event will AHS be liable for any incidental or consequential damages caused by defects in the appliance. Some states do not allow exclusions or limitation of incidental or consequential damages, so these limitations may not apply to you. This warranty gives you specific rights; you may also have other rights, which vary from state to state. EXCEPT TO THE EXTENT PROVIDED BY LAW, AHS MAKES NO EXPRESS WARRANTIES OTHER THAN THE WARRANTY SPECIFIED HEREIN. THE DURATION OF ANY IMPLIED WARRANTY IS LIMITED TO DURATION OF THE EXPRESSED WARRANTY SPECIFIED ABOVE.





Legacy Stoves™ - Advanced Design & Old Fashioned Values



(Signature of Boxer)

Your premium quality hearth product designed and assembled by the experienced and skilled members at Legacy Stoves™ in Harrisonville, PA, USA.

**LEGACY  
STOVES™**