

Jøtul F 600

Jøtul F 600

Installation and Operating Instructions for USA/Canada

2



Kindly save these instructions for future references.

USA/CANADA

Installation and Operating Instructions for the USA

Installation et fonctionnement pour Canada

Safety notice: If this solid fuel room heater is not properly installed, a house fire may result. For your safety, follow the installation directions. Contact local building or fire officials about restrictions and installation inspection requirements in your area. Kindly save these instructions for future reference.

Avis de sécurité: Une installation non appropriée de ce poêle de chauffage risque de provoquer un incendie. Assurez votre sécurité en respectant les directives d'installation suivantes. Consultez les autorités locales du bâtiment ou de la prévention des incendies au sujet des restrictions et exigences relatives aux inspections d'installations dans votre région.

Tested and listed by ITS, Intertek Testing Services, Middleton, Wisconsin.

Tested to U.S. Standards: ANSI/UL 1482 & 737, Canadian Standards: CAN/ULC-S627-M93



Standards:

The Jøtul F 600 woodstove has been tested and listed to;
U.S. Standards: ANSI/UL 737 and ANSI/UL 1482.
Canadian Standards: CAN/ULC-S627-M93

Tests performed by:

ITS Intertek Testing Services, Middleton, WI

Manufactured by:

Jøtul AS, P.O. Box 1411, N-1602 Fredrikstad, Norway

Distributed by:

Jøtul North America, 55 Hutcherson Drive, Gorham, Maine 04038, USA.

This heater meets the U.S. Environment Protection Agency's Emissions limits for wood heaters manufactured and sold after July 1, 1990.

Under specific test conditions, this heater has shown heat output at rates ranging from 13,500 to 45,900 BTU's per hour.

The Jøtul F 600 woodstove is **only** listed to burn wood. Do not burn any other fuels.

When installing, operating and maintaining your Jøtul F 600 woodstove, follow the guidelines presented in these instructions, and make them available to anyone using or servicing the stove.

Jøtul North America Inc.

55 Hutcherson Drive,
Gorham, Maine 04038,
USA

A number of areas require a building permit to install a solid fuel burning appliance.

In the U.S., the National Fire Protection Association's Code, NFPA 211, Standards for Chimneys, Fireplaces, Vents and Solid Fuel Burning Appliances, or similar regulations, may apply to the installation of a solid fuel burning appliance in your area.

In Canada, the guideline is established by the CSA Standard, CAN/CSA-B365-M93, Installation Code for Solid-Fuel-Burning Appliances and Equipment.

Always consult your local building inspector or authority having jurisdiction to determine what regulations apply in your area.

Accepted For Use
City of New York
Department of Buildings
MEA 313-00-E
Jøtul North America, Inc.



We suggest that our woodburning hearth products be installed and serviced by professionals who are certified in the U.S. by the National Fireplace Institute® (NFI) as NFI Woodburning Specialists or who are certified in Canada by Wood Energy Technical Training (WETT).



Jøtul pursues a policy of continual product development. Products as supplied may therefore differ in specification, colour, or type of accessories, from those illustrated or otherwise described in publications and brochures.

Table of Contents:

Standards and Safety Notices

Standards and Codes 2
 Safety Notices 3

1.0 Installation

Assembly before Installation.....4

2.0 Chimneys

Masonry Chimneys5
 Prefabricated Chimneys.....5
 Chimney Height.....5
 Wall Pass-throughs5

3.0 Connecting to the Chimney

Masonry Chimney Thimbles6
 Hearthmount into a Masonry Fireplace6
 Prefabricated Chimneys.....6

4.0 Clearances to combustibles

Floor Protection 7
 Clearances to Walls and Ceilings 7
 Using Shields to reduce Clearances..... 7
 Alcove Installation..... 8
 MobileHome Installation 8

5.0 Operation

Controls on The Jøtul F 600.....8
 Breaking in your new Stove8
 Starting and Maintaining a Fire9
 Adding Fuel9
 The Formation of Creosote9

6.0 Maintenance

Ash removal 10
 Glass care..... 10
 Chimney system 11

7.0 General Maintenance

Gaskets..... 11

8.0 Accessories

Firescreen 11
 Outside Air Kit..... 11
 Floor Bracket Kit.....12
 Rear Heatshield.....12
 Bottom Heatshield.....12
 Stove -Top Thermometer12
 Side Door Lock Kit.....12

9.0 Illustrations

Figures 13-14
 Clearance Chart and Diagrams 16-17
 Parts Diagram..... 18
 Appendix A (alternate floor protection) 19

Save these instructions and make them available to anyone using or servicing the stove.

Safety notices:

- Be sure to read this entire manual before you install or use your new Jøtul F 600 woodstove.
- If this room heater is not properly installed, a house fire may result. To reduce the risk of fire, follow the installation instructions. Failure to follow these instructions may result in property damage, bodily injury, or even death.
- Jøtul recommends that you have your new Jøtul F 600 installed by a professional installer of solid fuel burning appliances.
- Extremely hot while in operation! Keep children, clothing and furniture away. Contact may cause skin burns.
- Avoid creating a low pressure condition in the room where the stove is operating. Operating an exhaust fan or a clothes dryer could create a low pressure area, causing poisonous gases to come out of the stove into the room.
- You can prevent low pressure conditions by providing adequate combustion air within 24” but not closer than 12” from the stove. Or, simply install the optional outside air manifold system, which allows the direct connection of air from outside the house to the stove.
- Do not use chemicals or fluids to start the fire. Some fuels will, during combustion, separate carbon monoxide and generate it in the burn chamber. Carbon monoxide is toxic, so please follow the guidelines in this manual for proper operation of your Jøtul F 600.
- If you for some reason experience smoke “roll-out” from the stove, it may activate smoke detectors if installed in the house.

1.0 Installation

If this solid fuel room heater is not properly installed a house fire may result. For your safety, follow the installation directions. Contact the local building or fire officials about restrictions and installation inspection requirements in your area.

Reminder:

Your local officials have final authority in determining if a proposed installation is acceptable. Any requirement, that is requested by the local authority having jurisdiction, that is not specifically addressed in this manual, defaults to NFPA 211, and local codes in the U.S. or in Canada, CAN/CSA-B365-M and local codes.

1.1 Assembly before installation

The Jøtul F 600 is shipped with the flue collar, gasketing and hardware inside the stove.

- To install the flue collar in the top or rear exit position remove the tape from the gasketing and adhere to the groove on the back of the stove around the flue opening.
- Place the flue collar on the stove in the top or rear exit position and secure with the nut, bolt and washer.
- The nut and washer are placed on the inside of the stove.

1.2 Chimney connector

The chimney connector is a single walled pipe used to connect the stove to the chimney. For use with the Jøtul F 600, the chimney connector **must** be 6" in diameter, with a minimum thickness of 24 gauge black steel.

- Aluminum and Galvanized steel pipe is not acceptable for use with the Jøtul F 600. These materials cannot withstand the extreme temperatures of a wood fire and can give off toxic fumes when heated.
- **Do not use the connector pipe as a chimney.**
- Each chimney connector or stove pipe section must be installed to the stove flue collar and to each other with the male (crimped) end toward the stove. **See figure 2, page 13.**
- This prevents any amount of condensed or liquid creosote from running down the outside of the pipe or the stove top.
- All joints, including the flue collar connection must be secured with three sheet metal screws.
- For the best performance the chimney connector should be as short and direct as possible, with no more than two 90° elbows.
- **The maximum horizontal run is 36" and a recommended total length of stove pipe should not exceed 10 feet.**
- Always slope horizontal runs upward 1/4" per foot toward the chimney.
- No part of the chimney connector may pass through an attic or roof space, closet or other concealed space, or through a floor or ceiling.
- All sections of the chimney connectors must be accessible for cleaning.
- Where passage through a wall or partition of combustible construction is desired, the installation must conform with NFPA 211 or CAN/CSA-B365, and is also addressed in this manual.
- **Do not connect this unit to a chimney flue servicing another appliance.**

2.0 Chimney Requirements

There are two types of chimneys suitable for the Jøtul F 600:

1. A code- approved masonry chimney with a flue liner.
2. A prefabricated chimney complying with the requirements for Type HT (2100°F) chimneys per UL 103 or ULC S629.

The chimney size should not be less than the cross-sectional area of the flue collar, and not more than three times greater than the cross-sectional area of the flue collar.

When selecting a chimney type and the location for the chimney in the house, keep this in mind: it is the chimney that makes the stove work, **not** the stove that makes the chimney work. This is because a chimney actually creates a suction, called "draft", which pulls air through the stove.

Several factors affect draft: chimney height, cross-sectional area (size), and temperature of the chimney, as well as the proximity of surrounding trees or buildings.

As a result, a short masonry chimney on the exterior of a house will give the poorest performance. This is because it can be very difficult to warm the chimney thereby creating inadequate draft. In extremely cold northern areas it may be necessary to reline the chimney or extend its height to help establish draft.

Conversely, a tall masonry chimney inside the house is easier to keep warm and will perform the best.

The following guidelines give the necessary chimney requirements based on the national code (ANSI-NFPA 211 for the US. And CSA CAN-B365 for Canada). However, many local codes differ from the national code to take into account climate, altitude, or other factors.

Notice:

It is important that you check with your local building officials to find out what codes apply in your area before installing your new Jøtul F 600.

Remember: Your local inspector(s) have the final authority in approving your installation. It is always best to consult with them prior to the installation.

2.1 Masonry Chimneys

When installing the Jøtul F 600 into a masonry chimney you must conform to all of the following guidelines:

- The masonry chimney must have a fireclay liner or equivalent, with a minimum thickness of 5/8" and must be installed with refractory mortar. There must be at least 1/4" air space between the flue liner and chimney wall.
- The fireclay flue liner must have a nominal size of 8" X 8", and should not be larger than 8" X 12". If a round fireclay liner is to be used it must have a minimum inside diameter of 6" and not larger than 8" in diameter.
- If a chimney with larger dimensions is to be used, it should be relined with an appropriate liner that is code approved.
- The masonry wall of the chimney, if brick or modular block, must be a minimum of 4" nominal thickness. A mountain or rubble stone wall must be at least 12" thick.
- A newly-built chimney must conform to local codes and in their absence must recognize national regulations. When using an existing chimney, it must be inspected by a licensed professional chimney sweep, fire official, or code officer, to ensure that the chimney is in proper working order.

- No other appliance can be vented into the same flue.
- An airtight clean-out door should be located at the base of the chimney.

2.2 Prefabricated Chimneys

If a prefabricated metal chimney is to be used it must be a chimney type that is tested and listed for use with solid fuel burning appliances.

That means a chimney that is tested to the following:

High Temperature (HT) Chimney Standard UL 103 for the U.S. and High Temperature Standard ULC S-629 for Canada.

The manufacturer's installation instructions must be followed precisely. Always maintain the proper clearance to combustibles as established by the pipe manufacturer. This clearance is usually a minimum of 2", although it may vary by manufacturer or for certain chimney components.

2.3 Chimney Height

Whether a masonry chimney or prefabricated metal chimney is used it must be the required height above the roof line.

The requirement is:

The chimney must be at least 3 feet higher than the highest point where it passes through the roof and at least 2 feet higher than the highest part of the roof or structure that is within 10 feet of the chimney, measured horizontally. **See figure 3, page 13.**

Chimneys shorter than 14 feet may not provide adequate draft. This could result in smoke spilling into the room from the stove when loading the stove, or when the door is open. In addition, inadequate draft can cause back puffing, which is a build up of gases inside the firebox.

Other times, chimney height can create excessive draft which can cause high stove temperatures and short burn times. Excessive drafts can be corrected by installing a butterfly damper. If you suspect you have a draft problem, consult your dealer.

2.4 Wall Pass-throughs

When your installation unavoidably requires the chimney connector to pass through a combustible wall to reach the chimney, always consult your local building officials, and be sure any materials to be used have been tested and listed for wall pass-throughs.

In the U.S.

The National Fire Protection Association's publication, NFPA 211, Standard for Chimneys, Fireplaces, Vents and Solid Fuel Burning Appliances permits four methods for passing through a combustible wall. Before proceeding with any method be sure to consult with your local building officials to discuss any local code requirements.

Common Method:

- When passing through a combustible wall to a masonry chimney this method requires the removal of all combustible materials from at least 12" around the chimney connectors proposed location. With a 6" round liner the minimum area required would be 31" x 31" square.

- The space is then filled with at least 12" of brick around a fireclay liner. Remember, the liner must be ASTM C35 or equivalent, with a minimum wall thickness of 5/8".
- It is important to remember to locate the pass-through at least 18" from the ceiling for proper clearance to combustibles.
- It will be necessary to cut wall studs, install headers, and construct a sill frame to maintain the proper dimensions and to support the weight of the brick.
- The bricks must be solid brick with a minimum of 3 1/4" thick (4" nominal).
- Refractory mortar must be used at the junction of the chimney and the pass-through liner. The pass-through liner must not penetrate the chimney liner beyond the inner surface of the chimney liner. Use extreme care when constructing the hole in the chimney liner, the tiles can shatter easily. **See figure 4, page 13.**

In Canada

In Canada the standard has been established by the Canadian Standard Association. The installation must conform to CAN/CSA-B365, Installation Code for Solid Fuel Burning Appliances and Equipment. Before proceeding be sure to consult your local building inspector.

Common Method:

This method requires the removal of all combustible materials from at least 18" (457mm) around the chimney connector's proposed location. With a 6" round liner the minimum area required would be 43" x 43" square.

It is important to remember to locate the pass-through at least 18" from the ceiling to maintain the proper clearance to combustibles.

The space that is cleared of combustible materials must then remain empty. Sheet metal panels can then be used to cover the area. However, when using a panel on both sides of the wall each cover must be installed on noncombustible spacers at least 1" from the wall. If one panel of sheet metal is to be used it may be installed flush to the wall.

See section 5.3.1 and 5.3.2 of CAN/CSA - B365-M91.

Consult your local building inspector, authorized Jøtul Dealer, NFPA 211 in the U.S. or CAN/CSA-B635 in Canada for other approved wall pass-through methods.

3.0 Connecting to the chimney

3.1 Masonry Chimney Thimbles

When installing a Jøtul F 600 into a masonry chimney through a “thimble” (the opening through the chimney wall to the flue), the thimble must be lined with ceramic tile or metal and be securely cemented in place.

The chimney connector/stove pipe must slide completely inside the thimble to the inner surface or the flue liner. It may be necessary to make use of a thimble sleeve (a pipe with a slightly smaller diameter than standard stove pipe). This special pipe can be easily installed into a thimble. **See figure 5, page 14.**

Make sure the connector pipe or thimble sleeve does not protrude into the flue liner, thereby restricting the area the smoke has to flow through. This bottle-neck will have a negative affect on the chimney system.

The chimney connector should be sealed at the thimble with refractory cement and the stove pipe leading to the stove should have a minimum of three screws.

Do not connect this stove to a chimney flue servicing another appliance of any kind.

3.2 Hearthmount Into a Masonry Fireplace

The Jøtul F 600 may be installed into a masonry fireplace provided the height of the opening is a minimum of 31”.

When installing the Jøtul F 600 into a masonry fireplace, code requires that the fireplace damper plate be removed or securely fixed in the open position. A connector pipe must then extend from the stove’s flue exit through the damper area of the fireplace and into the chimney tile liner. **See figure 6, page 14.**

The inside area of the flue liner must not be less than the area of the stove’s flue exit, and cannot be more than three times greater than the cross sectional area of the stove’s flue exit.

If the chimney liner is too large to accommodate the stove, an approved relining system must be installed to resize the flue.

A new sheet metal damper block-off plate must be installed around the connector pipe at the damper frame and sealed with the proper sealant (usually High-Temp Silicone).

Fireplace installation must also observe the proper clearances to surrounding trim and mantels (addressed in clearance section of this manual). In addition, fireplace installations must also adhere to the floor protection guidelines specified in the following section.

3.3 Prefabricated Chimneys

When installing the Jøtul F 600 to a prefabricated metal chimney always follow the pipe manufacture’s instructions and be sure to use the components that are required. This usually includes some type of “smoke pipe adapter” that is secured to the bottom section of the metal chimney and allows the chimney pipe to be secured to it with three sheet metal screws. **See figure 7, page 14.**

4.0 Clearances to Combustibles

4.1 Floor Protection

Floor protection under the stove must be constructed of a non-combustible material for protection from radiant heat, sparks, and embers.

Individual sections of floor protection must be mortared together to prevent sparks from falling through to combustible materials. Any carpeting must be removed from under the floor protection.

In the U.S. and Canada

The Jøtul F 600 must be installed on a non-combustible surface extending:

A minimum of **18” (460mm)** in front of the stove and the right side load door (measured from the legs).

And **8” (200mm)** on the left side and back of the stove (measured from side and back panels).

This will result in a minimum floor protection of **55”W X 50”D**. **See figure 8, page 14.**

In a rear vent installation the floor protection must also extend under the stove pipe a minimum of **2” (50mm)** beyond either side of the pipe.

A hearth pad measuring **45” wide X 53” deep** can be used. However, use of the right side load door is prohibited when this size hearth is used; because access to the firebox is only allowed through a door that has a minimum of **18” (460mm)** of hearth protection.

When constructing a new hearth or floor pad, consult appendix a at the back of this manual for alternate materials and methods.

4.2 Clearances to Walls and Ceilings

The following clearances have been tested to UL and ULC standards and are the minimum clearances specifically established for the Jøtul F 600.

The following diagrams give the required clearances you must maintain when installing the Jøtul F 600 near combustible surfaces. **See pages 16-17.**

A combustible surface is anything that can burn (i.e. sheet rock, wall paper, wood, fabrics etc.). These surfaces are not limited to those that are visible and also include materials that are behind non-combustible materials.

If you are not sure of the combustible nature of a material, consult your local fire officials. Contact your local building officials about restrictions and installation requirements in your area.

Remember: “Fire Resistant” materials are considered combustible; they are difficult to ignite, but will burn. Also “Fire-rated” sheet rock is also considered combustible.

4.3 Using Shields to Reduce Clearances

Pipe shields: When using listed pipe shields to reduce the connector clearance to combustibles, it must start 1" above the lowest exposed point of the connect pipe and extend vertically a minimum of 25" above the top surface of the stove.

Double wall pipe: Listed double wall pipe is an acceptable alternative to connector pipe heatshields.

Wall-Mounted Protection: When reducing clearances through the use of wall mounted protection:

In the U.S. refer to NFPA 211, Standard for Chimneys, Fireplaces, Vents and Solid Fuel Burning Appliances, for acceptable materials, proper sizing and construction guidelines.

In Canada, refer to CAN/CSA-B365, Installation Code for Solid-Fuel Burning Appliances and Equipment, also for acceptable materials, proper sizing and construction guidelines.

Stove Mounted Heatshield: A stove rear heatshield has been specifically designed for the Jøtul F 600.
Rear heatshield part # 154329.

No other heat shield may be used.

See pages 16-17 for complete clearance requirements and diagrams.

Notice

Accessories for wood stoves for clearance reduction have been developed by many manufacturers. If not following the methods of the installation codes, be sure that any accessory you choose has been tested by an independent laboratory and carries the laboratory's testing mark. Make sure to follow all of the manufacturer's instructions.

Always contact your local building inspector or fire officials about restriction and requirements in your area. Reminder, it is the local officials who have final authority in the installations approval.

4.4 Alcove Installation

The Jøtul F 600 can be installed in an alcove situation provided:
See figures 9 and 10, page 14.

1. The stove must be installed with listed double walled pipe.
2. In a protected alcove installation both side walls and rear wall must be protected per NFPA 211 or CAN/CSA-B365. The wall protection must be elevated 1" from the floor and at least 1" off the combustible wall to allow for an air-flow.
3. The height of the wall protection including the bottom air space must be 48".
4. The bottom heatshield is **required in all** alcove installations.
5. If a UL/ULC listed hearth pad is not used, the hearth must be constructed of noncombustible material having a minimum R-value of 0.5."(see appendix a, page 19).
6. Minimum ceiling height in an unprotected installation, off the top of the stove is 48" (1220mm). The minimum ceiling height off the top of the stove in a *protected* ceiling installation is 15" (380mm).

Use of the right side load door is prohibited in alcove installations. Install Side Door Lock kit 221100 available from your Jøtul dealer.

Mobile Home Installations

The Jøtul F 600 has been approved for use in mobile homes in the U.S. and Canada, provided:

1. The stove is secured to the floor or the mobile home. Floor mounting kit #750304.
2. The stove is provided outside air for combustion. Outside Air kit #154333 (see page 11 for more details)
3. The stove must be grounded to the mobile home frame per NFPA 70.

As always, consult with your local building inspector or fire officials about restrictions and requirements in your area prior to installing the stove.

Warning:

Do not install in a bedroom/sleeping room. The structural integrity of the mobile home's floor, wall, ceiling/roof must be maintained.

5.0 Operation

Before building a fire in your new Jøtul F 600, please read the following section carefully and completely.

Important

The detachable Door Handle is combustible and not intended to be permanently attached to the stove. Keep it nearby, where it will be easily accessible and always cool to touch.

This stove is designed to burn natural wood **only**. Wood that has been air-dried for a period of 6 to 14 months will provide the cleanest most efficient heat.

Do not burn:

- | | |
|-------------|------------------------------|
| * Coal | * Treated or painted wood |
| * Garbage | * Chemical Chimney cleaners |
| * Cardboard | * Colored paper |
| * Solvents | * Any synthetic fuel or logs |

The burning of any of these materials can result in the release of toxic fumes. Never use gasoline, gasoline-type lantern fuel, kerosene, charcoal lighter fluid, or similar liquids to start or “freshen-up” the fire. Always keep such liquids away from the heater at all times.

Important

Never build or allow the fire to rest directly on the glass. The logs should always be spaced at least one inch from the glass to allow for proper air flow within the stove.

5.1 Controls on The Jøtul F 600

A single air control lever controls the burn time and heat output of the stove. This primary air control lever is located on the front of the stove directly above the ashlip. The primary air lever controls the amount of air that enters the stove for combustion.

When first starting or reviving the fire: The primary control lever should be at the far right position, which allows the maximum amount of air into the stove.

The more air entering the stove, the hotter the fire, the shorter the burn time. Moving the lever to the left reduces the air-flow into the stove which prolongs the fire at a lower heat output. See figure 11, page 15.

5.2 Breaking in Your New Stove

Your new Jøtul F 600 is constructed of cast iron and stove furnace cement. This type of construction requires the stove to be “broken-in” gradually so that heat expansion does not occur too quickly and cause damage.

Complete the following steps for the proper break-in procedure for the Jøtul F 600:

To monitor the stove’s temperature, Jøtul recommends the use of a magnetic stove-top thermometer, *placed directly on the corner of the stove’s top plate.*

1. Light a small fire, newspaper and kindling only, only allow the stove to reach a maximum surface temperature of 200°. Burn for approximately 1 hour.
2. Allow stove to cool to room temperature.
3. Light a second fire, allowing the stove to reach a maximum temperature of 300° for 1 hour.

4. Cool the stove to room temperature.
5. Light a third fire and gradually allow the stove to reach a surface temperature of 400°
6. Cool stove to room temperature. This completes the “break-in” procedure.

Never allow the stove to exceed a 400° surface temperature during any “break-in fire” with the exception of the last “break-in” fire.

Note: It is normal for a new painted stove to emit an odor and even smoke during its first several fires. This is caused by the seasoning of the high temperature paint and will diminish with each fire and will eventually disappear. Opening a window or door to provide additional ventilation will reduce the odor as this process takes its course.

5.3 Starting and Maintaining a Fire

Burn only solid wood directly on the bottom grate of the stove, do not elevate the fire in any way.

- The ash pan door on the stove must always be securely closed when the stove is in operation.
- Burning the stove with the ash pan door open will overfire the stove and cause interior damage.
- With the primary air control lever in the full open position, start with several sheets of crumbled newspaper placed directly on the grate. On top of the newspaper, place several pieces of small dry kindling (approx. 1” in diameter) with two to three larger logs (approx. 3” to 5” in diameter) on top.
- Light the fire and close the door, slowly building the fire by adding larger and larger logs. Be sure to follow the break-in procedure before creating a fire that will damage the stove.
- Once the stove has reached a surface temperature range of between 400° and 600°, adjust the primary air control lever as necessary to generate the heat output and burn time desired.
- Jøtul recommends the use of a magnetic stove top thermometer to monitor the surface temperature of the stove. The optimum surface temperature range for the most efficient burn is between 400° to 600°. See figure 12, page 15, for the optimum locations of a stove-top thermometer.

5.4 Adding Fuel

When reloading the stove while it is still hot and a bed of hot embers still exist, follow this reloading procedure:

- Always wear gloves when tending to the stove.
- Push the air control lever to the full open position (far right).
- Wait a few seconds before opening the door.
- Use a stove tool or poker to distribute the hot embers equally around the firebox.
- Load the fuel, usually with smaller logs first.
- Close the door, be sure to latch the door tightly.
- Wait 5 – 10 minutes before adjusting the primary air to the desired heat output setting. (If you have at least a 2” thick ember bed when reloading, it may be possible to close the door and immediately adjust the air control setting).

5.5 The Formation of Creosote

Creosote and Soot Formation and the Need for Removal

When wood is burned slowly, it produces tar and other organic vapors which combine with expelled moisture to form creosote.

These creosote vapors condense in the relatively cool chimney flue of a slow burning fire. The creosote that accumulates in the flue is highly flammable and is the fuel of chimney fires. To prevent a chimney fire, the creosote needs to be removed by sweeping the chimney and flue connector. The frequency of sweeping will depend on how you operate your stove, but it is important to inspect the flue after every two weeks of use. An accumulation of 1/4" or more on the sides of the flue or connector is considered hazardous and should be removed.

In the event that creosote in your chimney or flue connector ignites, the resulting fire is often accompanied by a roaring noise and a crackling sound as flakes of burned creosote break loose. If you suspect you are having a chimney fire, immediately close the draft regulator and make sure the stove door is closed. Call the fire department and get everyone safely out of the house.

Trying to extinguish the fire in the stove will not help. In fact it can make the matter worse by allowing oxygen through the door, which then supports the fire in the chimney. When the roaring and crackling has stopped, you should resist the temptation to open the door and look at the fire. The fire may have suffocated, but could rekindle when you open the door. After a chimney fire, do not use your stove until the chimney and the flue connector has been cleaned and inspected to ensure that no damage has been sustained.

6.0 Maintenance

6.1 Ash Removal

For your protection always wear safety gloves when handling the ash pan.

Ash removal will be required periodically depending on how frequently the stove is used. Conveniently, the Jøtul F 600 is equipped with an ash pan assembly for easy ash removal, without the need for opening the front doors.

The ash pan door is located under the front ashlip of the stove. To open the ash door rotate the door knob counterclockwise to unlatch the door and clockwise to latch the door.

Remove the ash pan. When the stove is in operation always close the ash door before leaving to dispose of the ashes.

The ashes should be placed in a metal container equipped with a tight sealing lid. The container should be placed on a noncombustible floor or on the ground, well away from all combustible materials, pending final disposal. If the ashes are disposed of by burial in soil or otherwise locally dispersed, they should be retained in the closed container until all cinders have thoroughly cooled.

6.2 Glass Care

Cleaning:

On occasion it will be necessary to clean the carbon deposits and fly ash off of the glass. If the carbon and fly ash are allowed to remain on the glass for an extended period of time it could eventually cause the glass to become etched and cloudy. Any creosote, which might deposit on the glass, should burn off during the next hot fire.

The proper cleaning procedure is as follows:

1. Glass needs to be completely cool.
2. Only use a cleaner that is specifically designed for this purpose. The use of abrasives will damage the glass and ultimately leave the glass frosted.
3. Rinse and dry glass completely before burning your stove.

Never operate the stove with a cracked or broken glass panel.

Glass removal:

Always operate the doors slowly and cautiously to avoid cracking or breaking the glass. Never use the door to push wood into the firebox. If the glass becomes cracked or broken follow this procedure for replacement:

1. Remove the door from the stove and place on a flat surface.
2. Carefully remove all of the glass clips from the inside of the door.
3. Gently remove all pieces of the glass panel and gasketing.
4. Remove all remaining debris from the glass area using a wire brush.
5. Apply a small bead of gasket/stove cement and the new gasket. Do not overlap the ends of the gasket rope.
6. Center the new glass panel over the gasket and reinstall the glass clips. **See figure 13, page 15.**

Important: The side of the glass treated with an infrared coating (marked on the perimeter) should always be facing outward. It is extremely important to tighten the glass clips slowly and in a repeating pattern, like tightening the lugs on an automobile wheel.

It may be necessary to retighten the glass clips after the stove has burned and the gasketing has been seated.

Important:

Replace glass only with a ceramic glass panel specifically designed for the Jøtul F 600. Do not use substitutes. Replacement glass panels can be ordered through your Jøtul dealer.

6.3 Chimney System

The Jøtul F 600 is designed to burn cleanly and efficiently when used according to the guidelines in this manual. In order to maintain proper performance, you should inspect the chimney and chimney connector at the beginning of each heating season and then, twice a month during the heating season. Clean the chimney whenever creosote and fly ash accumulation exceeds 1/4 inch in any part of the system.

Chimney brushes are available from your local Jøtul dealer or hardware supply store. Your dealer can also refer you to a reputable, professional chimney sweep who will have all the equipment to ensure a complete and proper job. Failure to keep the chimney system free of creosote and build up could result in a serious chimney fire.

7.0 General maintenance

Like your car, regular maintenance prolongs the life of your stove. The following procedures do not take long and are generally inexpensive, but when done consistently, increase the life of your stove and in turn, increase your years of enjoyment.

Enamel Care:

- DO NOT ATTEMPT TO CLEAN HOT ENAMEL SURFACES. Clean only cold enamel surfaces with a soft damp cloth and polish with a clean dry cloth. DO NOT USE SOAPY OR ABRASIVE SOLUTIONS. These can cause stains. Coffee, tea, and fruit juices will also cause stains.
- Avoid contact with metal objects. Trivets, kettles, or pots, can damage the enamel.
- Empty stove of all soot and ashes. Only use a vacuum for this job if the vacuum is specifically designed for ashes.
- Inspect the stove: Using a strong light inspect the stove inside and out for cracks or leaks. Replace all cracked parts and repair any cement leaks with furnace cement.

7.1 Gaskets

Check door and window gaskets for tightness.

To check the seal of the front doors, close and latch the doors on a dollar bill and slowly try to pull the dollar bill free. If it can be easily removed then the seal is too loose. Check several spots around the door, and repeat the procedure on the ash pan door as well.

- If gaskets need to be replaced, scrape out the old gasket and cement and clean the area with a wire brush.
- Apply a small bead of cement and push in the new gasket.
- After closing and latching the doors wipe clean any excessive cement that has come from beneath the gasketing.

Description	Size	Length
Right door,	ld375	ø9,5 mm (3/8") 900 mm (36")
Left door,	ld375	ø9,5 mm (3/8") 900 mm (36")
Left door, middle	ld250	ø6,4 mm (1/4") 410 mm (18")
Right glass,	ld250	ø6,4 mm (1/4") 1050 mm (42")
Left glass,	ld250	ø6,4 mm (1/4") 1050 mm (42")
Ash pan door,	ld250	ø6,4 mm (1/4") 1100 mm (45")
Right side load door,	ld375	ø9,5 mm (3/8") 1400 mm (56")

The Jøtul F 600 is designed to burn cleanly and efficiently when used according to the guidelines expressed in these operating instructions. However, to maintain the proper performance, a yearly chimney inspection and cleaning is necessary. Failure to keep the chimney system free of creosote and build up could result in a serious chimney fire.

8.0 Accessories

Many accessories have been manufactured for use with the Jøtul F 600. Only use accessories that are specifically designed for the Jøtul F 600.

8.1 Firescreen

The Jøtul F 600 has been approved for use as an open fireplace, with front doors open. This feature is especially nice when the ambience of a fire is desired. Some care should be taken when operating the stove as a fireplace.

- Always have the firescreen in place, attached to the stove front.
- Never over load the stove: For the best appearance burn in the traditional three log configuration.
- Reminder, when burning the stove with the screen in place, you are sacrificing efficiency for aesthetics, and you will be consuming wood at a much faster rate.

Warning: Operate your Jøtul F 600 with the front doors fully open and the firescreen in place or fully closed. Partially opened doors may result in overfiring. Also, if doors are left partly open, gas and flame may be drawn out of the stove opening, creating risks from both fire and smoke.

8.2 Outside Air Kit

In certain installations it may be necessary to provide outside air to your Jøtul F 600 wood stove. Guidelines to determine the need for additional combustion air may not be adequate for every situation. If in doubt, it is advisable to provide additional air.

The outside air kit includes an adapter to mount onto the stove that will accept the fresh air pipe. Installation will require some additional materials:

- A. The appropriate length of metallic pipe for a conduit of the outside air (4" diameter).
- B. A rain/weather resistant cap for the outside of the house.
- C. A rodent screen - that is no larger than 1/4" mesh.

Outside air may be required if:

1. The Jøtul F 600 does not "draw" steadily, smoke rollout occurs, fuel burns poorly, or back-drafts occur whether or not there is combustion present.
2. Existing fuel-fired equipment in the house, such as fireplaces or other heating appliances, smell, do not operate properly, suffer smoke roll - out when opened, or back-draft whether or not there is combustion present.
3. Opening a window slightly on a calm (windless) day alleviates any of the above symptoms.
4. The house is equipped with a well-sealed vapor barrier and tight fitting windows and/or has any powered devices that exhaust house air.
5. There is excessive condensation on the windows in the winter.
6. A ventilation system is installed in the house.

If these or other indications suggest that infiltration air is inadequate, additional combustion air should be provided from the outdoors. Outside combustion air can be provided to the appliance by the following means:

Direct connection: The Jøtul F 600 has been tested and listed for use with an outside air kit. This outside air kit is connected directly to the stove. Be sure to follow the instructions provided with the kit.

Indirect method: Outside air is ducted to a point no closer than (12") 300mm from the appliance, to avoid affecting the performance of the appliance.

A mechanical ventilation system: If the house has a ventilation system (air change or heat recovery):

A. The ventilation system may be able to provide sufficient combustion make-up air for the solid fuel fired appliance.

B. The homeowner should be informed that the ventilation system might need to be rebalanced by a ventilation technician after installation of the appliance.

8.3 Floor Bracket Kit

Use of the floor bracket kit is required in all mobile home installations to secure the stove to the floor. Complete installation instructions and diagrams are supplied with each floor bracket kit.

8.4 Rear Heatshield

A stove rear heatshield has been specifically designed for the Jøtul F 600 to reduce clearances off the rear of the stove to combustible materials. Use of the heatshield **does not** affect the clearance off the sides of the appliance.

See pages 11-12 for specific clearance requirements. Complete installation instructions are supplied with the heatshield. No other type of heatshield may be used on the rear of the Jøtul F 600.

8.5 Bottom Heatshield

A bottom heatshield has been specifically designed for the Jøtul F 600. It is required in all alcove installations. Use of the bottom heatshield **does not** affect the floor protection requirements described on page 9 of this manual. No other type of heatshield may be used on the bottom of the Jøtul F 600.

8.6 Stove-top Thermometer

Jøtul recommends the use of a magnetic stove-top thermometer to monitor the surface temperature of the stove. The optimum surface temperature range for the most efficient, clean burn is between 400° and 600°.

8.7 Side Door Lock Kit

Use of the Side Door is prohibited in any Corner installation or Alcove installation in which the door is closer than 36" to a combustible wall. Kit 155850 is available specifically for the Jøtul F 600 for use in these cases. With installation, it locks the door latch in a closed position.

Fig. 1a

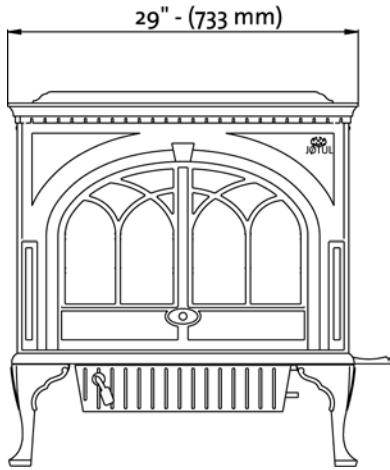

Fig. 2

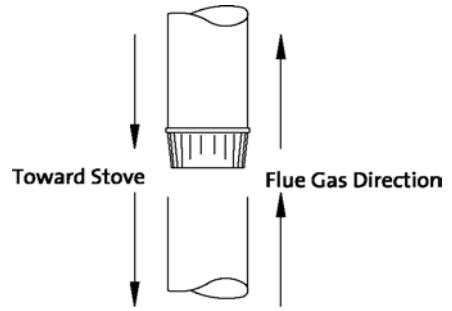

Fig. 1b

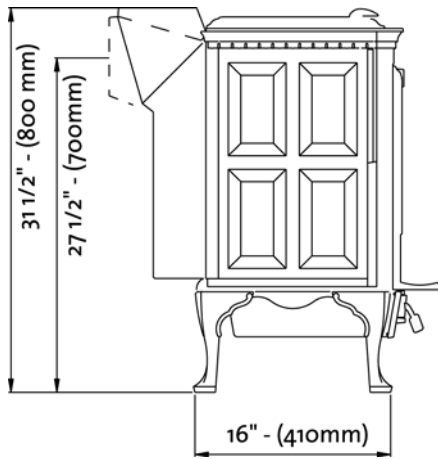

Fig. 3

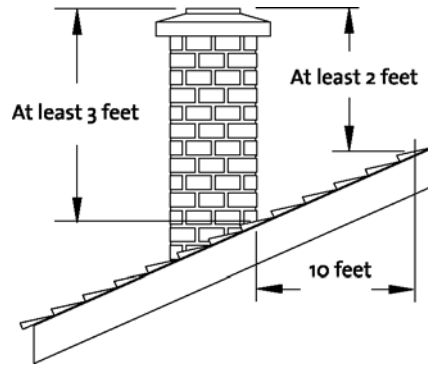

Fig. 1c

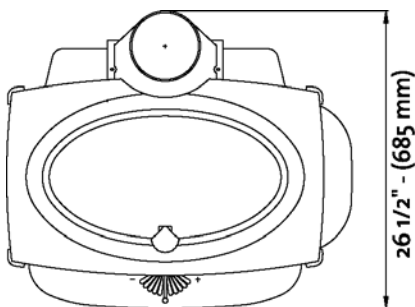

Fig. 4

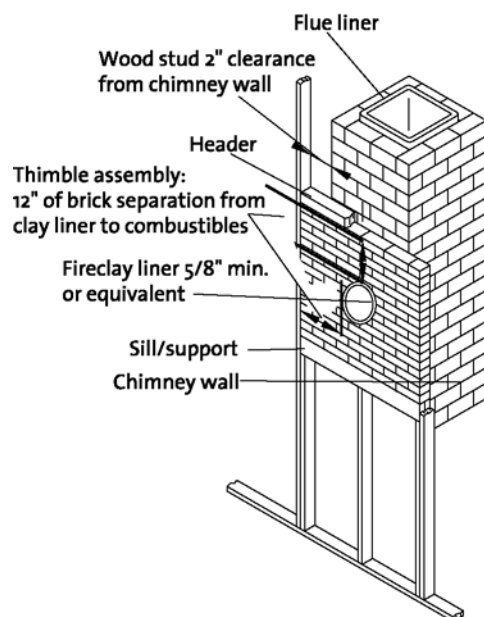

Fig. 5

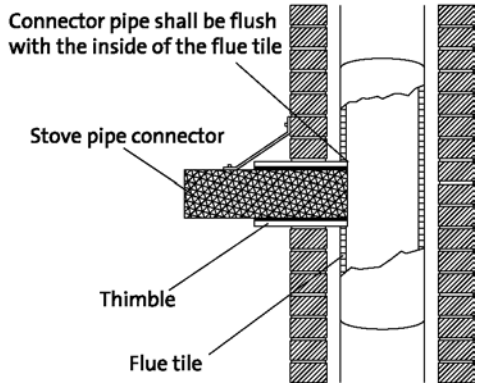

Fig. 8

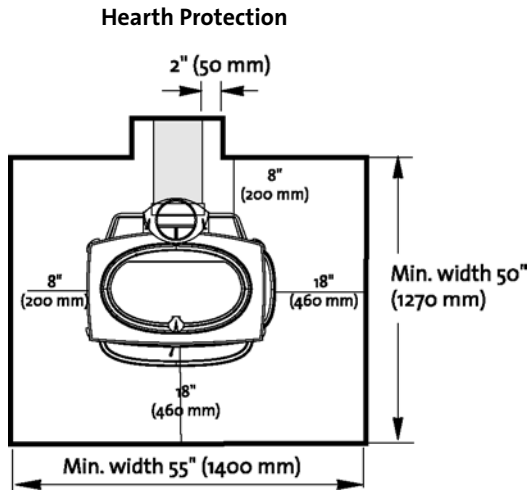

Fig. 6

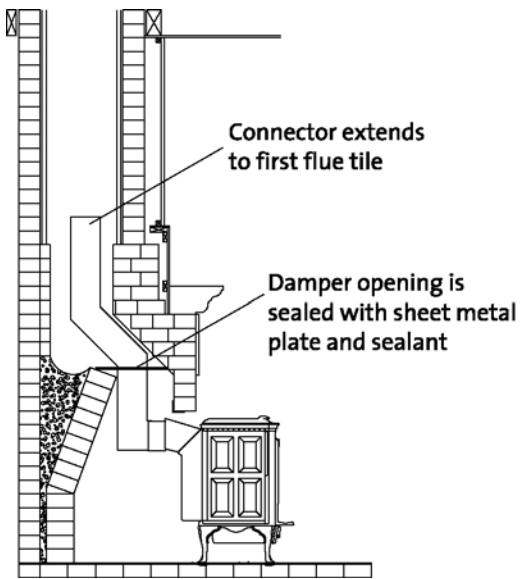

Fig. 9

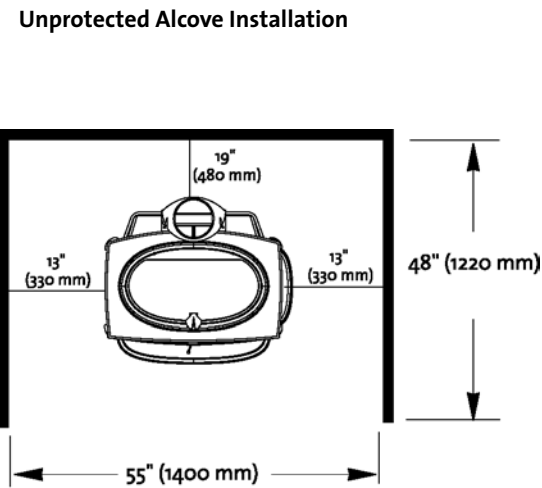

Fig. 7

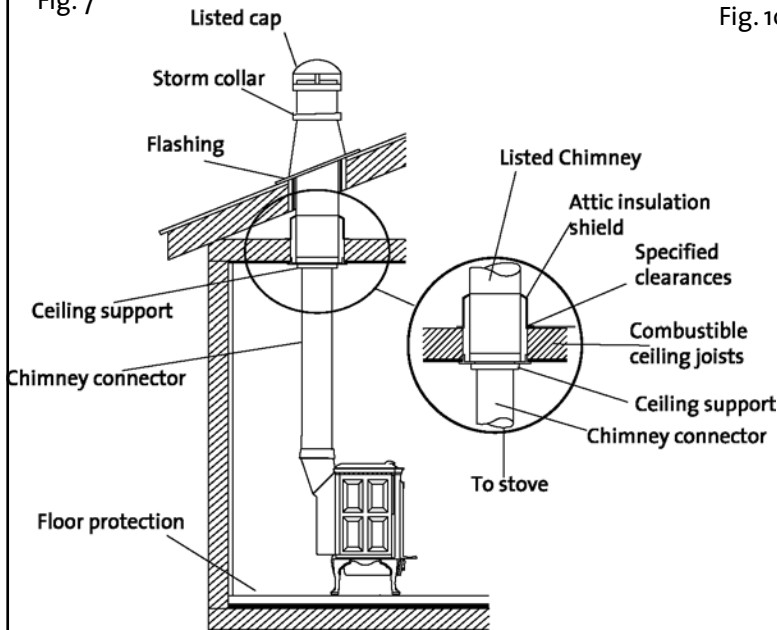

Fig. 10

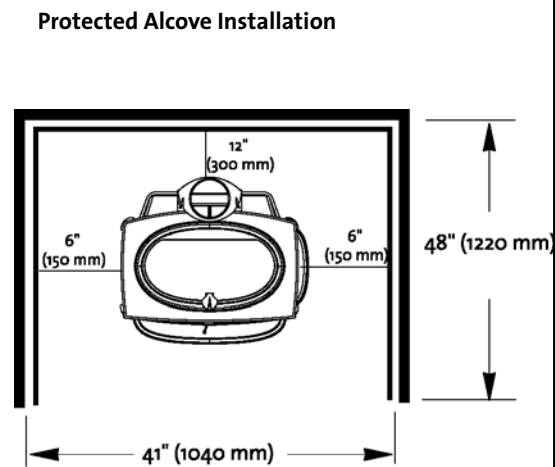

Fig. 11

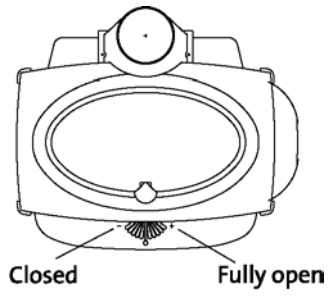

Fig. 12

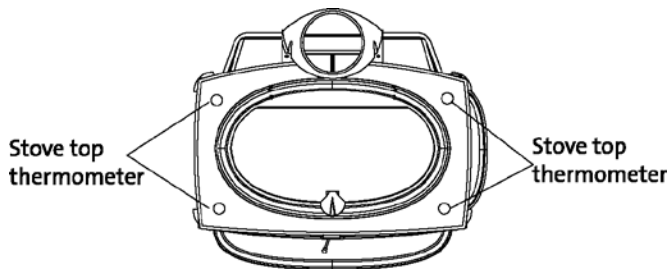
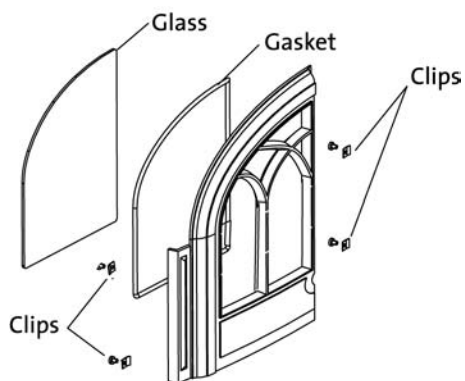
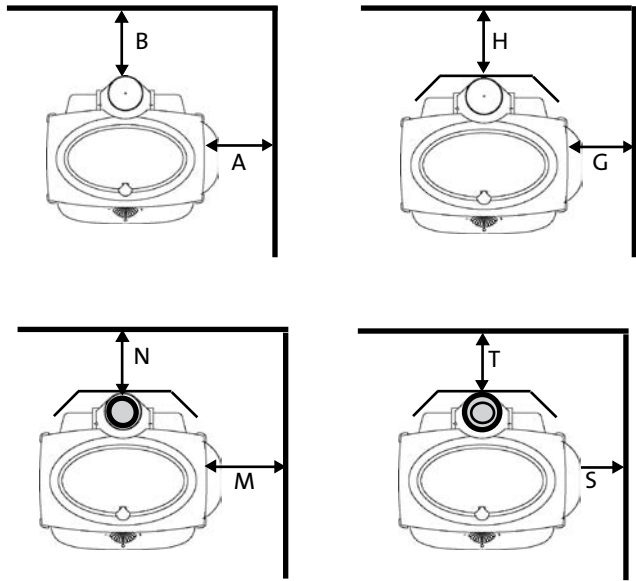

Fig. 13



Jøtul F 600 Woodstove Clearances

Unprotected Surface Parallel to the Wall



Protected Surface Parallel to the Wall

PER NFPA 211 or
CAN/CSA-B365

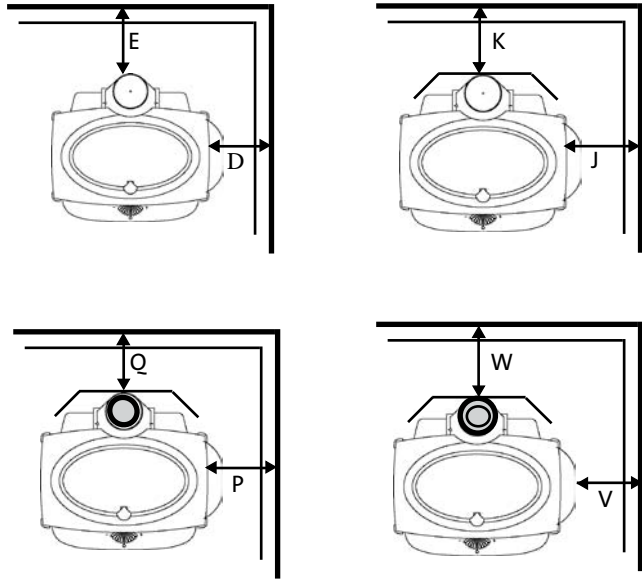

Important:
Connector heatshields and double wall pipe must be a listed product.
Always follow the manufacturer's instructions.



Unprotected Surface Corner Installation

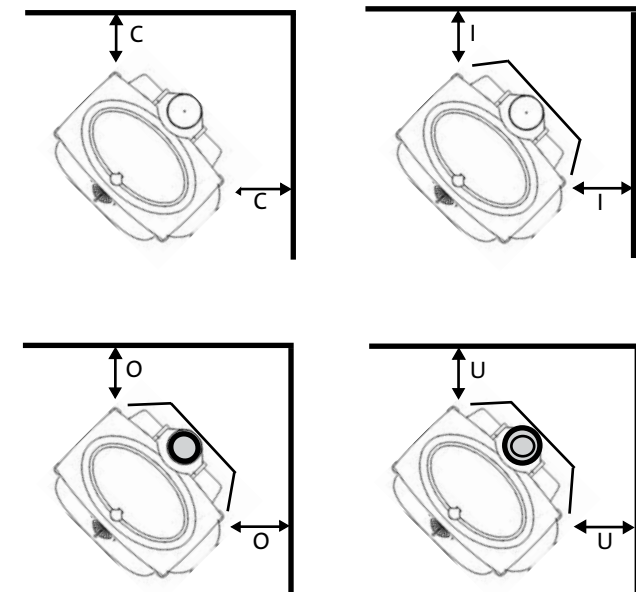

Protected Surface Corner Installation

PER NFPA 211 or
CAN/CSA-B365

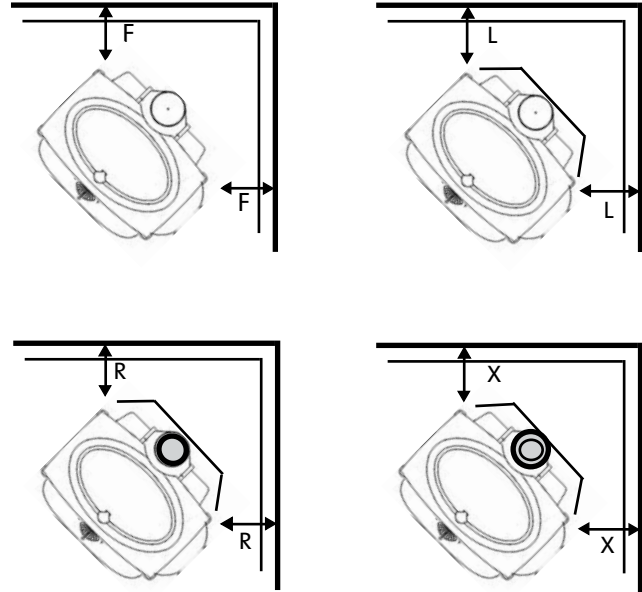

Jøtul F 600 Woodstove Clearances

Stove clearances	Unprotected surface Parallel installation			Protected surface NFPA 211 Parallel installation		
	Side	Rear	Corner*	Side	Rear	Corner*
Stove- no heatshields Single wall pipe	13" A 330mm	19" B 480mm	13" C 330mm	6" D 150mm	12" E 300mm	9" F 230mm
Stove with rear heatshield Single wall pipe	13" G 330mm	13" H 330mm	10" I 250mm	6" J 150mm	12" K 300mm	9" L 230mm
Stove with rear heatshield With connector shield	13" M 330mm	8" N 200mm	10" O 250mm	6" P 150mm	8" Q 200mm	6" R 150mm
Stove with rear heatshield With double wall pipe	13" S 330mm	8" T 200mm	9" U 230mm	6" V 150mm	8" W 200mm	6" X 150mm

Connector clearances (pipe)	Unprotected surface Vertical installation		Protected surface NFPA 211 Vertical installation	
Single wall pipe	18" 460mm		12" 300mm	
Single wall pipe with connector shields	7" 180mm		7" 180mm	
Double wall pipe	6" 150mm		6" 150mm	

Connector clearances (pipe)	Unprotected surface Horizontal installation		Protected surface NFPA 211 Horizontal installation	
Single wall connector	18" 460mm	12" 300mm		
Double wall pipe	6" 150mm	6" 150mm		
Mantel and trim clearances	Stove to 1" thick or less, side trim		11" 280mm	
	Stove to 1" thick or less, top trim		17" 430mm	
	Stove to mantel- maximum mantel depth 11"		26" 660mm	

* **Attention: Stove and pipe clearances must both be taken into consideration. The greater clearance dictates the stove's position.**

* **Use of the right side load door is prohibited in alcove and corner installations.**

* **Use of the right side load door is prohibited in alcove or corner installations. Use Side Door Lock Kit # 155850.**

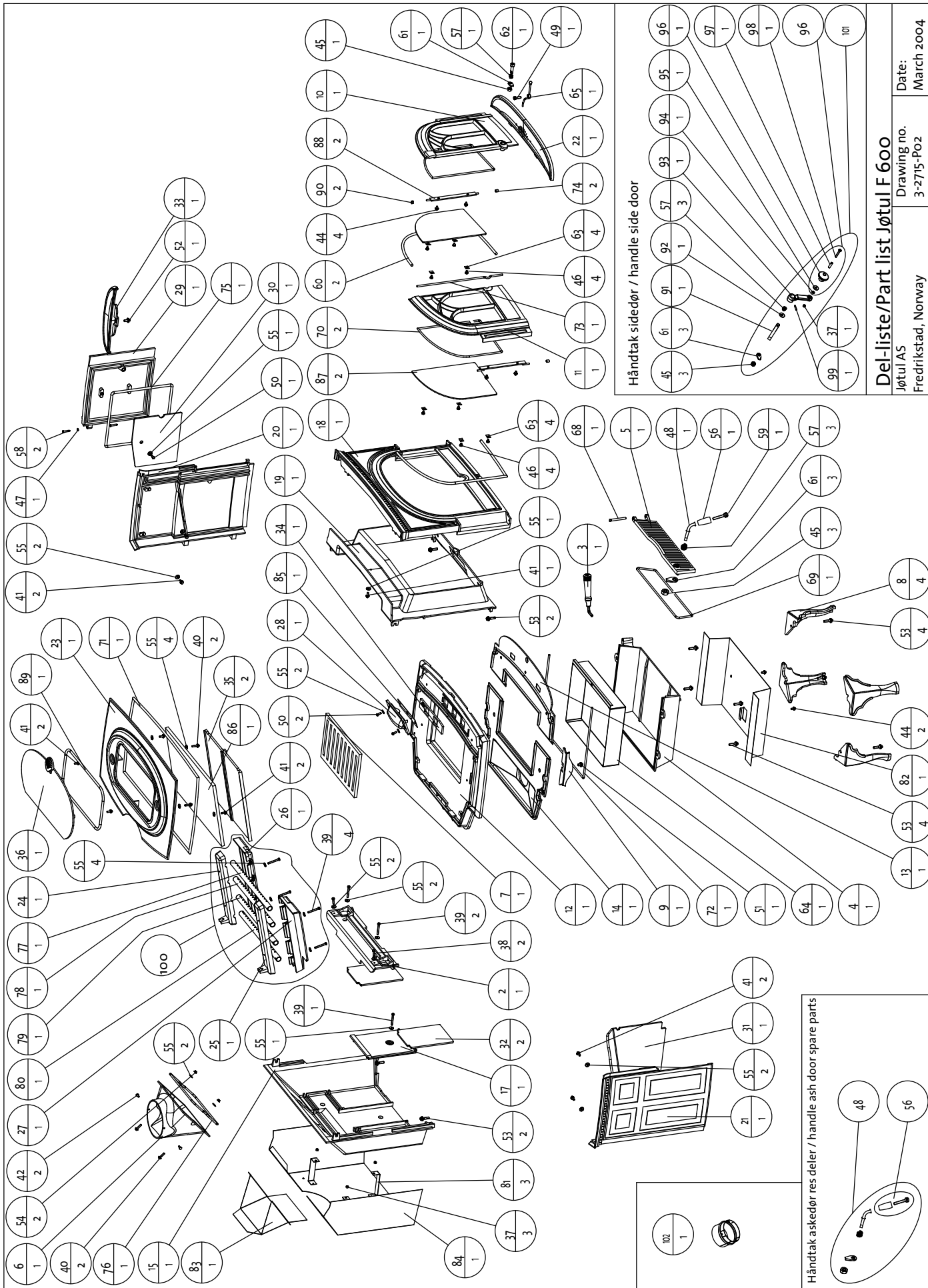

Del-liste/Part list Jøtul F 600

Jøtul AS
Fredrikstad, Norway

Date:
March 2004

Drawing no.
3-2715-Po2

102 1

99 1

97 1

96 1

95 1

94 1

93 1

92 1

91 1

90 2

88 2

87 2

86 1

85 1

84 1

83 1

82 1

81 3

80 1

79 1

78 1

77 1

76 1

75 1

74 2

73 1

72 1

71 1

70 2

69 1

68 1

67 1

66 1

65 1

64 1

63 4

62 1

61 1

60 1

59 1

58 2

57 3

56 1

55 4

54 2

53 4

52 1

51 1

50 1

49 1

48 1

47 1

46 4

45 3

44 2

43 1

42 2

41 2

40 2

39 4

38 2

37 3

36 1

35 2

34 1

33 1

32 2

31 1

30 1

29 1

28 1

27 1

26 1

25 1

24 1

23 1

22 1

21 1

20 1

19 1

18 1

17 1

16 1

15 1

14 1

13 1

12 1

11 1

10 1

9 1

8 4

7 1

6 1

5 1

4 1

3 1

2 1

1 1

100 1

100 1

100 1

100 1

100 1

100 1

100 1

100 1

100 1

100 1

USA/CANADA

Part list for Jøtul F 600

Pos. no.	Description	Pos. no.	Description
2	Tube Frame Holder	85	Air Restrictor
3	Handle	86	Insulation Blanket
4	Ash House Compl.	87	Glass
5	Ash Door	88	Front Door Hinge
6	Smoke Outlet	89	Gasket (Top Cover)
7	Fire Grate	90	Shaft Collar Ø6 X Ø12 X 6 mm
8	Leg	91	Latch Bolt Side Door
9	Decorative Cover Side	92	Washer
10	Door Right w/o Glass, Ver 3	93	Latch
11	Door Left w/o Glass, Ver 3	94	Washer
12	Bottom	95	Washer, Insulating
13	Inner Bottom, Front Part	96	Wooden Knob Side Door
14	Inner Bottom, Rear Part	97	Distance Sleeve for Side Door
15	Rear Plate	98	Screw Pan Head
17	Air Manifold	99	Pin
18	Front	100	Air Chamber Complete
19	Inner Front	101	Handle Side Door Complete
20	Side Right	102	Adapter Outside Air
21	Side Left		
22	Ash Lip Front		
23	Top		
24	Tube Holder Upper Right		
25	Tube Holder Upper Left		
26	Tube Holder Bottom Right		
27	Tube Holder Bottom Left		
28	Inspection Cover		
29	Side Door		
30	Burnplate Side Door		
31	Burnplate Left		
32	Burnplate Rear		
33	Ash Lip Side		
34	Air Valve		
35	Baffle Plate		
36	Top Cover		
37	Nut Stainless		
38	Screw Hexagon Stainless		
39	Screw Hexagon		
40	Screw Collar Hexagon		
41	Screw Collar Hexagon		
42	Screw Selfthread		
43	Screw Collar Hexagon		
44	Screw Collar Hexagon		
45	Nut Hexagon		
46	Screw Panh. (Front Door)		
47	Washer		
48	Latch Bolt Ash Door		
49	Screw Allen		
50	Screw Hexagon Stainless		
51	Screw Collar Hexagon		
52	Screw Collar Hexagon		
53	Screw Collar Hexagon		
54	Nut Collar Hexagon		
55	Washer		
56	Wooden Knob Ash Door		
57	Spring for Latch Bolt		
58	Hinge Pin Front/Side Door		
59	Screw Syl. Head		
60	Gasket (Door to Front)		
61	Latch		
62	Latch Bolt		
63	Glass Clip		
64	Ash Pan		
65	Handle for Air Vent		
68	Hinge Pin, Ash Door		
69	Gasket (Ash Door)		
70	Gasket (Glass)		
71	Gasket (Top)		
72	Gasket (Ash House)		
73	Gasket (Left Door Middle)		
74	Sleeve for Door Hinge		
75	Gasket (Side Door)		
76	Gasket (Smoke Outlet)		
77	Tube First From Front		
78	Tube Second From Front		
79	Tube Third From Front		
80	Tube Forth From Front		
82	Bottom Heatshield		
83	Heatshield Top Exit		
84	Rear Heatshield		

Alternate floor protection

All floor protection materials must be non-combustible (ie. metal, brick, stone, mineral fiber boards). Any combustible material may not be used.

The easiest means of determining if a proposed alternate floor material meets requirements listed in this manual is to follow this procedure.

R-value = thermal resistance

k-value = thermal conductivity

C-value = thermal conductance

- Convert the specification to R-value;
 - If R-value is given, no conversion is needed.
 - If k-value is given with a required thickness (T) in inches: $R=1/k \times T$.
 - If C-value is given: $R=1/C$.
- Determine the R-value of the proposed alternate floor protector.
 - Use the formula in Step 1 to convert values not expressed as "R".
 - For multiple layers, add R-values of each layer to determine overall R-value.
- If the overall R-value of the system is greater than the R-value of the specified floor protector, the alternate is acceptable.

Example:

The specified floor protector should be 3/4" thick material with a k-factor of 0.84. The proposed alternate is 4" brick with a C-factor of 1.25 over 1/8" mineral board with a k-factor of 0.29.

Step A. Use formula above to convert specifications to R-value. $R=1/k \times T = 1/.84 \times .75 = .893$

Step B. Calculate R of proposed system.

4" brick of C-1.25, therefore

$R \text{ brick} = 1/C = 1/1.25 = 0.80$.

1/8" mineral board of $k = 0.29$ therefore

$R \text{ mineral board} = 1/.29 \times 0.125 = 0.431$

Total R = R brick + R mineral board =

$0.8 + 0.431 = 1.231$

Step C. Compare proposed system R = 1.231 to specified R of 0.893. Since R is greater than required, the system is acceptable.

Definitions:

Thermal conductance =

$$C = \frac{\text{Btu}}{(\text{hr})(\text{ft}^2)(\text{F})} = \frac{W}{(\text{m}^2)(\text{K})}$$

Thermal conductivity =

$$k = \frac{\text{Btu}}{(\text{hr})(\text{ft}^2)(\text{F})} = \frac{W}{(\text{m}^2)(\text{K})} = \frac{(\text{Btu})}{(\text{hr})(\text{ft})(\text{F})}$$

Thermal resistance =

$$R = \frac{\text{Btu}}{(\text{hr})(\text{ft}^2)(\text{F})} = \frac{(\text{m}^2)(\text{K})}{W} = \frac{(\text{Btu})(\text{inch})}{(\text{hr})(\text{ft}^2)(\text{F})}$$

Alcove installations require noncombustible hearth materials having a minimum insulating R-value of 0.5.

Sluttkontroll av ildsteder

Quality control of stoves and fireplaces

Checked

Utført	Kontrollpunkt	Controlled item
✓	Alle deler er med i produktet (ifølge struktur).	All parts are included.
✓	Alle festemidler er av korrekt type, og er korrekt anvendt.	Correct fastener items have been used and correctly applied.
✓	Overflater er i samsvar med Jøtuls kvalitetsstandarder.	Surfaces comply with Jøtul workmanship standards.
✓	Lukkemekanismer fungerer som de skal, og uten behov for unødig stor kraft.	Door locking mechanisms function correctly; excessive force is not needed.
✓	Produktet/serien møter kravet for lekkasjetest.	The product/lot complies with the leakage test requirement.
✓	Lakkerte/emaljerte overflater møter kravene i Jøtuls kvalitetsstandarder.	Paint/enamel surface finish complies with Jøtul workmanship standards.
✓	Produktet er fritt for utvendig kitt- eller limklin.	Surfaces are not contaminated by external stove cement or glue.
✓	Produktet har ingen sprekker i glass, støpejern eller andre deler.	There are no cracks in glass, cast iron or other parts.
✓	Pakninger er riktig lagt, og skjemmer ikke produktet ved stygge ender eller ved at pakningen er unødig synlig.	Gaskets are correctly applied and do not degrade product appearance (i.e. loose ends or excessive visible exposure).
✓	Dørpakninger er godt limt.	Door gaskets are firmly glued/fixed to the door.
✓	Dørpakninger har tilfredsstillende pakningstrykk.	Door gaskets provide satisfactory sealing.
✓	Sjekk at det ikke "lyser gjennom" i dørpakning eller andre sammenføyninger.	Check for "light through" at door seals and other relevant locations.
✓	Trekkhender osv fungerer normalt.	The function of air valve handle etc is normal.

Jøtul bekrefter herved at dette produktet er kontrollert og funnet å være i samsvar med våre kvalitetsnormer.	Jøtul hereby confirm that this product has been QC inspected and found to comply with our quality standards.	
Lot#/Serie nr.	Checked by/ kontrollert av	Date/Dato:

Cat.no. 129211
Draw.no. 4-3600-P06
Møkklegaards Trykkeri AS, Feb. 2009

Jøtul pursue a policy of constant product development. Products supplied may therefore differ in specification, colour and type of accessories from those illustrated and described in the brochure.

Quality

Jøtul AS has a quality system that conforms to NS-EN ISO 9001 for product development, manufacturing, and distribution of stoves and fireplaces. This policy gives our customers quality and safety piece of mind as a result of Jøtul's vast experience dating back to when the company first started in 1853.

Jøtul North America Inc.
55 Hutcherson Drive
Gorham, Maine 04038
USA

Jøtul AS
P.o. box 1411
N-1602 Fredrikstad,
Norway

