



# HEARTLAND®

1260 E. VanDeinse, Greenville, MI 48838  
Phone (800) 223-3900 Fax (616) 754-9690



The Oval and Sweetheart cookstoves are listed to CSA Standard B366.2M ULC Standard S-627 & UL 1482 by Warnock Hersey Professional Services Ltd.

NOTE: Warnock Hersey NBR is 219.

## INSTALLATION AND OPERATING INSTRUCTIONS

### SAVE THESE INSTRUCTIONS FOR FUTURE USE

**Note:** Please read these instructions thoroughly before attempting to install this unit.

**SAFETY NOTICE:** IF THIS STOVE IS NOT PROPERLY INSTALLED, A HOUSE FIRE MAY RESULT. FOR YOUR SAFETY, FOLLOW THE INSTALLATION DIRECTIONS. CONTACT LOCAL BUILDING OR FIRE OFFICIALS ABOUT RESTRICTIONS AND INSTALLATION INSPECTION REQUIREMENTS IN YOUR AREA.

**IMPORTANT:** Check around oven chamber on a **weekly** basis for soot and creosote accumulation. Clean the chamber thoroughly from the top, side and bottom with the rake (part #1425) provided. Burn the stove hot daily to reduce creosote accumulation. Use only dry wood aged for one year. **Failure to do so could result in chimney fire and void the warranty.**

**OVERFIRING CAUTION:**  
Repeated or extended overfiring will void warranty on this appliance.  
See page 31 for details.

The temperature registered by the oven door thermometer may not necessarily correspond with the reading taken with the thermometer inside the oven. *For accurate oven temperatures, refer to the interior oven thermometer.*

**PLEASE NOTE:** Specifications contained in this manual are subject to change with out notice

# WOOD COOKSTOVES

Manual #1705 110512

**ATTENTION INSTALLER:** Leave this manual with appliance

## Oval

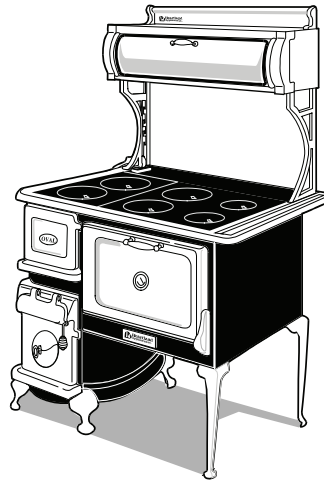

Oval  
With Towel Rack  
#1902

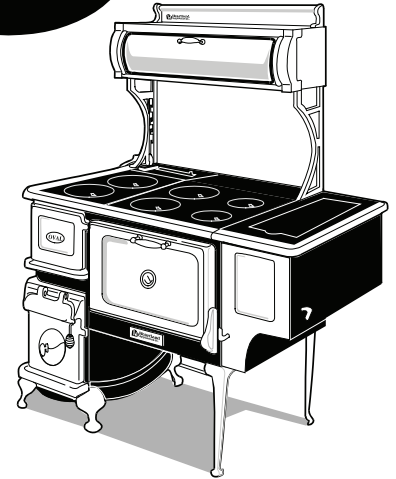

Oval  
With Reservoir  
#1903

## SweetHeart

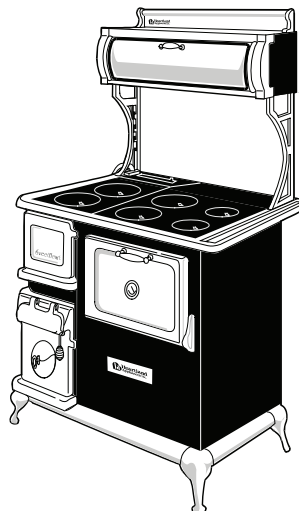

SweetHeart  
With Towel Rack  
#2602

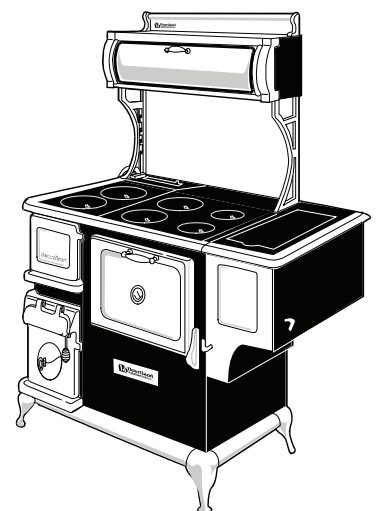

SweetHeart  
With Reservoir  
#2603

© 2010 AGA Marvel

---

---

## **— FOR YOUR SAFETY—**

**DO NOT STORE OR USE GASOLINE OR OTHER FLAMMABLE VAPOURS OR LIQUIDS IN THE VICINITY OF THIS STOVE.**

**Stove Location - If the range must be located near a window, avoid using long curtains which could blow over the stove top, causing a fire hazard.**

**Any openings in the wall behind the stove or in the floor under the range must be sealed.**

**Do not set unopened glass or metal containers in the oven, or in the warming cabinet, or on the cooking surface.**

**Grease accumulation is the cause of many cooking fires. Clean the oven compartment regularly.**

**Do not attempt to extinguish a grease fire with water. Cover grease fires with a pot lid or baking soda.**

**Avoid the use of aerosol containers near the range.**

**Never place pans, cookie sheets or roasters directly on the oven bottom but use the oven rack in its lowest position.**



## Oval & Sweetheart Models

### CONSUMER WARRANTY

#### ENTIRE PRODUCT – LIMITED ONE YEAR WARRANTY

AGA Marvel warrants the replacement or repair of all parts of this Wood Cookstove which prove to be defective in material or workmanship, with the exception of the painted or porcelain enamel finish or plated surfaces, for one year from the date of original purchase. Such parts will be repaired or replaced at the option of Heartland without charge, subject to the terms and conditions set out below.

The warranty period against defects in the painted or porcelain enamel finish, or plated surfaces, is 90 days from date of original purchase. **The warranty does not include normal wear of firebox parts or gaskets.**

#### TERMS AND CONDITIONS

- 1 This warranty applies only for single family domestic use when the Wood Cookstove has been properly installed according to the instructions supplied by Heartland and is connected to an adequate and proper chimney and chimney connections. Damage due to faulty installation, improper usage and care, abuse, accident, fire, flood, acts of God, commercial, business or rental use, and alteration, or the removal or defacing of the serial plate, cancels all obligations of this warranty. Service during this warranty must be performed by a factory Authorized Service Person.
- 2 Warranty applies to product only in the country in which it was purchased.
- 3 Heartland is not liable for any claims or damages resulting from any failure of the Wood Cookstove or from service delays beyond their reasonable control.
- 4 To obtain warranty service, the original purchaser must present the original Bill of Sale, Model and Serial number. Components repaired or replaced are warranted through the remainder of the original warranty period only.
- 5 The warranty does not cover expense involved in making this appliance readily accessible for servicing.
- 6 This warranty gives you specific legal rights. Additional warranty rights may be provided by law in some areas.
- 7 Adjustments such as calibrations, levelling, tightening of fasteners, or chimney and chimney connections normally associated with original installation are the responsibility of the dealer or installer and not that of the Company.
- 8 Overfiring of this appliance will void warranty.
9. If the product is installed outside the normal service area, any cost of transportation expenses (tolls, ferry trip charges, or mileage expenses, etc.) involved in the repair of the product, or the replacement of a defective part, shall be borne by the customer (owner).

**TO ENSURE PROMPT WARRANTY SERVICE, SEND IN YOUR WARRANTY CARD WITHIN 10 DAYS OF PURCHASE.**

If further help is needed concerning this warranty, contact:

Customer Service

AGA Marvel

1260 E. VanDeinse

Greenville MI 48838

Phone (800) 223-3900

Fax (616)754-9690

PLACE OF PURCHASE \_\_\_\_\_

DATE OF PURCHASE \_\_\_\_\_

SERIAL NUMBER \_\_\_\_\_

MODEL NUMBER \_\_\_\_\_

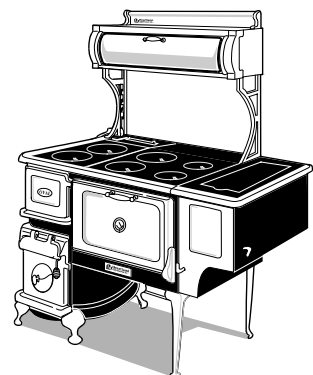

<b>Installation Instructions</b> .....	5
Unpacking.....	5
Assembly.....	6
Cabinet Installation.....	7

<b>Installation</b> .....	9
Clearances.....	9
Rough In for Oval Diagram.....	10
Rough In for SweetHeart Diagram.....	11
Chart of Clearances.....	12
Clearance Reductions.....	13
Floor Protection.....	13

<b>Chimneys and Draft</b> .....	13
Recommended Chimney Clearances.....	13
Chimney Connection Requirements.....	14

<b>Optional Accessories</b> .....	14
Heat Shield Kit.....	14
Fresh Air Kit.....	15
Water Jacket.....	15

<b>Fuel</b> .....	16
Woodburning.....	16

<b>Understanding Combustion</b> .....	17
Getting Acquainted.....	17
Starting the Stove.....	17
Break In Fire.....	18
Your First Fire.....	18
Summer Burning.....	19

<b>Coal Burning</b> .....	20
Sweetheart Coal Grate.....	20
Oval Coal Grate.....	20
Oval and Sweetheart Fire Door Damper.....	20
Starting Up a Coal Fire.....	20
Recharging the Fire.....	21
Disposal of Ashes (wood and coal).....	21
Use Caution.....	21

## Using the Oven and Cooking

<b>Surface</b> .....	22
Stove Top Cooking.....	22
Oven Cooking.....	23
Water Reservoir.....	24

<b>Trouble Shooting</b> .....	25
Chimneys and Draft.....	25
How Chimneys Work.....	25
Factors that Affect Draft.....	25
Checking an Existing Chimney.....	25
Safety Practices.....	26
<b>What To Do If You Have a Chimney Fire</b> .....	26

<b>Maintenance</b> .....	27
Oven Flue Passage.....	27
Flue Boot Inspection.....	28
Oven Damper.....	28
Chimney Maintenance.....	28
Cooking Surface.....	28
Nickel Trim.....	28
Porcelain.....	28
Door Gaskets.....	29
Firebox.....	29
Oven Thermometer Adjustment.....	29
Formula for Equivalent Hearth Extension.....	29

<b>Terms of Reference and Function</b> .....	30
--	----

<b>Over Firing-Caution!</b> .....	31
-----------------------------------	----

<b>Oval Parts Diagram</b> .....	33
---------------------------------	----

<b>SweetHeart Parts Diagram</b> .....	34
---------------------------------------	----

<b>Replacement Parts Diagram</b> .....	35
--	----

<b>Cookstove Parts List</b> .....	36
-----------------------------------	----

# — Welcome —

Your Heartland Cookstove is a time proven design of North American heritage. Our cookstoves were first made in 1906 and many originals are still in use today.

With proper operation and maintenance, your Heartland cookstove will give your family generations of warmth, delightful meals and untold pleasures.

Take the opportunity to read this manual thoroughly to become familiar with all the installation, operation and maintenance procedures for your stove. You will find it offers valuable insight into how a cookstove functions.

## Save These Instructions

Keep the manual available for future reference. The manual is an important part of your stove. If your stove is sold, deliver the manual to the new owner along with the stove.

The quality of the installation (especially the chimney connector and chimney), and the quality of the fuel being burned will affect the performance of your stove, but the most important factor is the way you operate the stove. With the help of this manual, you will learn how to effectively heat and cook with your stove. Be sure to read it entirely, including the terms of reference and function.

In addition, your own experience will help you to learn the role that the chimney plays in stove performance. The Oval & Sweetheart have been tested and are listed by Underwriters' Laboratories of Canada and Underwriters' Laboratories in the U.S. The test standards are ULC S-627 and UL 1482.

The Oval & Sweetheart are listed for burning wood or coal (with the optional coal grate). Do not burn other fuels. The Oval & Sweetheart are not listed for installation in mobile homes. Do not install the stove in mobile homes.

**Safety Notice: *If your stove is not properly installed and maintained, a house fire may result. For your safety, follow all installation, operation and maintenance directions. Contact local building officials about restrictions and installation inspection requirements in your area. ("Makeshift" compromises in the installation may result in hazardous conditions, including a house fire.)***

Spend some time becoming familiar with the various parts by operating them before you burn your stove.

After a few weeks of operating the stove re-read this manual. Many of the procedures will become clearer after you have had some experience with the stove.

## Installation Instructions

Preparing the installation site before moving the stove into it will save you from having to move the stove more than once. See **page 9** for information on "**Clearances**" and "**Floor Protection**" **page 13**.

## Unpacking

The stove is packaged in two main boxes. The smaller box contains the warming cabinet. The main stove body is strapped to the skid. Smaller component parts are packaged as follows:

Flu Body - (Oval only)

Flu body for the oval is fastened to the skid and must be assembled to the stove. Assembly instructions are on the following pages.

In the firebox:(Sweetheart and Oval)

1 ash scraper

The ash pan contains the following parts:(Sweetheart and Oval)

1 poker

1 tool rack

1 lid lifter

1 cooking surface lift handle w/screw and nut

3 bell damper handles w/rod

3 bell dampers

1 Heartland oven cleanout door

1 bag of hardware

1 interior oven thermometer

Reservoir models only:(Sweetheart and Oval)

1 package containing:

water tap (tap thread wrapped with teflon tape)

tap trim washer

# Assembly

## Oval / Sweetheart

Before removing the oval stove from the skid, the flu body must first be attached to the stove back. Follow the instructions below.

- 1) Unscrew the flu body from the skid and set aside.
- 2) Unscrew 3 sheet metal screws (2 along the bottom of the oven at the bottom and 1 along left side - see illustration)
- 3) Remove the first level only **of nuts and washers from the screws extending out the back of the stove (7pcs)**
- 4) Place flu body on back of stove so that the nuts on the screws fit inside the holes in the flange on each side of the flu body.
- 5) While holding the flu body in place, attach the flu to the stove by putting on a washer and nut on each screw, hand tight only.
- 6) Install the sheet metal screws along the bottom and side of the flu body, and tighten up.(3 places)
- 7) Tighten up the remaining nuts (7 places)

**Warning:** The stove is very heavy. Since the legs may dig into a soft floor, do not locate the stove, or even set it to rest, on a surface that could be imprinted. We recommend that 3 or 4 persons be available to assist in the lifting of the stove, and that gloves should be worn to protect hands from cuts.

- 1) First, remove the screws that are holding the flu body to the skid and remove the flu body.
- 2) Next, unscrew the two lag bolts which are securing the front and back of the firebox base. Lighten the stove by removing the keyplate and lids.
- 3) Look under the oven and note that the stove must be lifted up, over the wooden brace located there.
- 4) With 2 persons on the heavier, firebox side (left), and one person on the other side, lift the stove up, off of the skid and onto its new location.
- 5) If possible, have a fourth person remove the skid while the others lift.

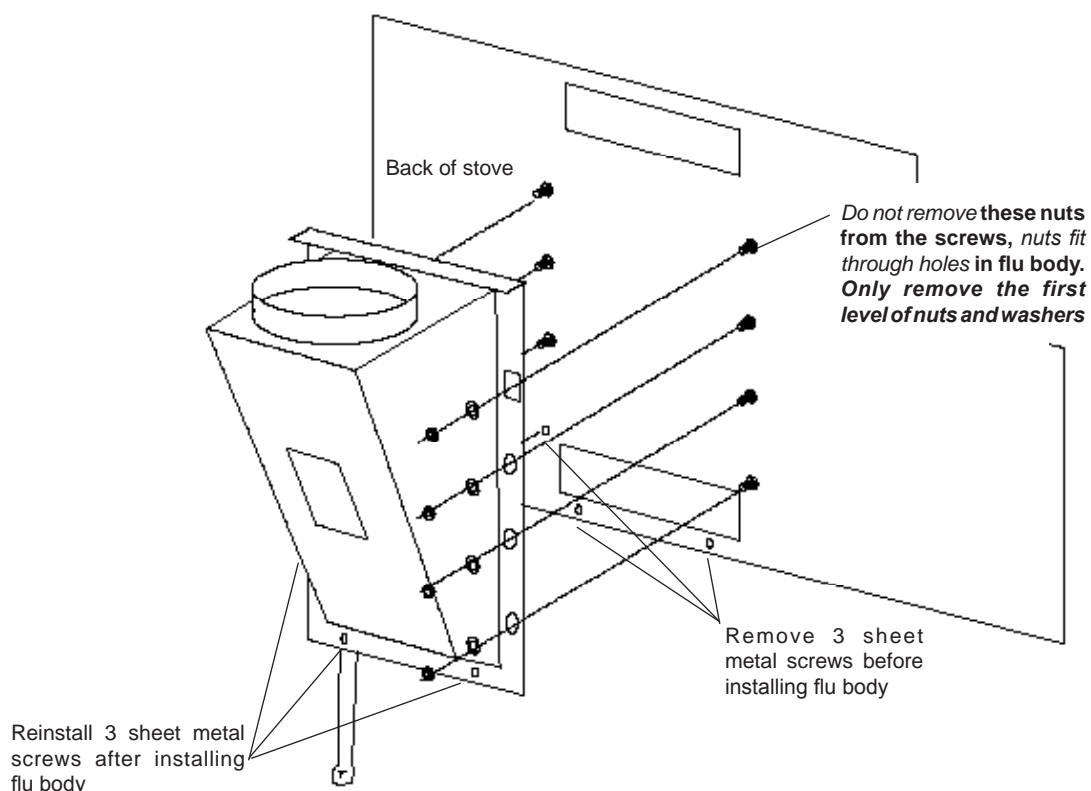



## Cabinet Assembly to Stove Top

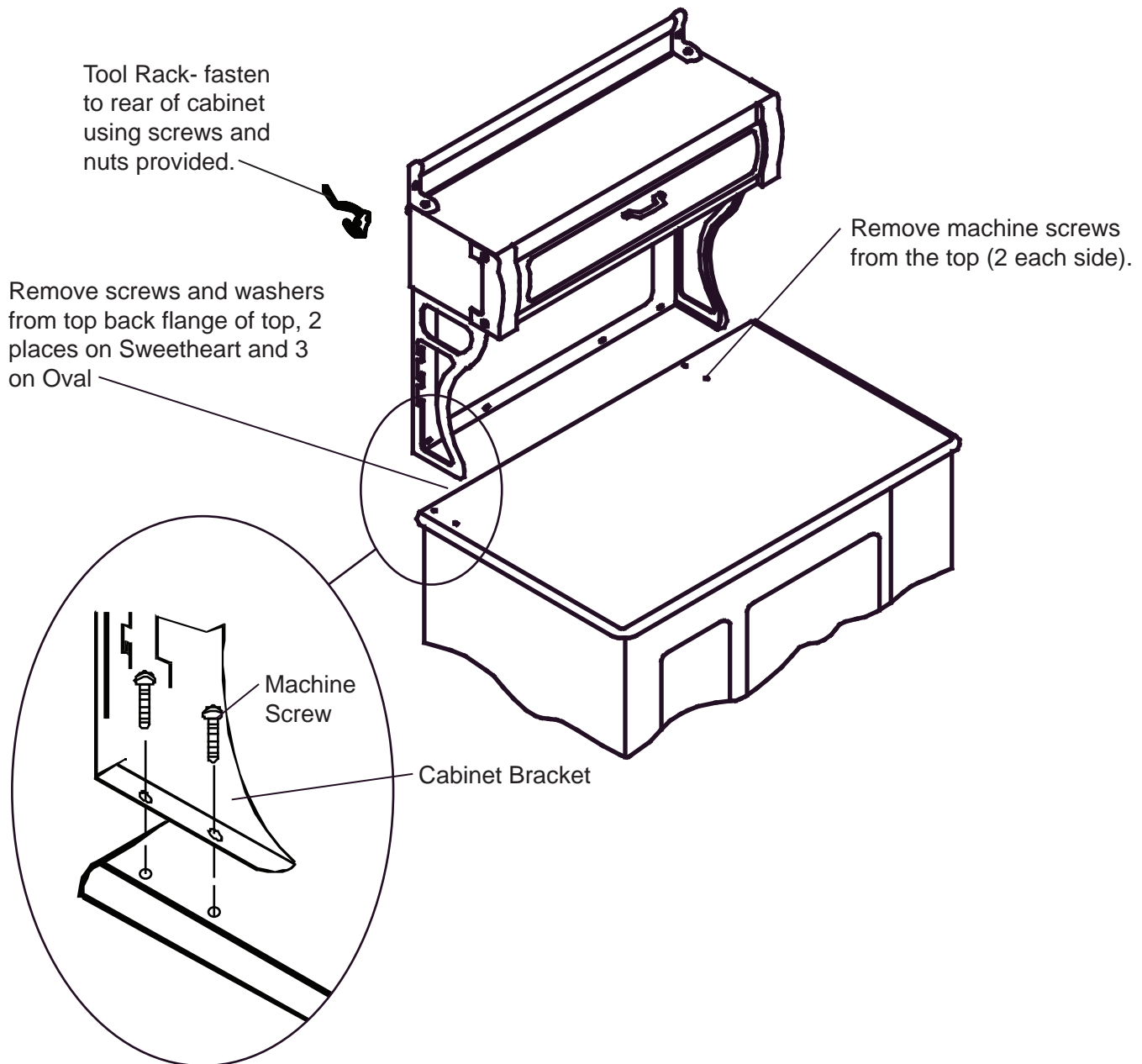

Remember when working with the cabinet it is top heavy. Use your hand to support it during installation. Remove the cabinet assembly from the top of the stove. Lift the cabinet assembly by the bracket area that is circled and set on the floor or a table top. Unwrap the cabinet assembly.

Remove the washers and screws from the rear edge of the stove top. (2 places on sweetheart or 3 places on Oval. Also remove the 4 machine screws from the top of the stove top.

With a helper lift the cabinet assembly (by the circled bracket area and supporting the top of the cabinet) and place the cabinet into position on the stove top (see diagram above). Line up the bracket holes with the 4 holes in the stove top while a helper supports the cabinet.

Secure the cabinet to the stove top with the 4 machine screws and the 2 or 3 screws and washers. **To prevent chipping do not overtighten screws or use power tools.**

## Oval and SweetHeart:

1. Assemble the bell dampers (Fig. 2) and thread into the three locations, one at the front in the ash pan door, and two on the firebox side.

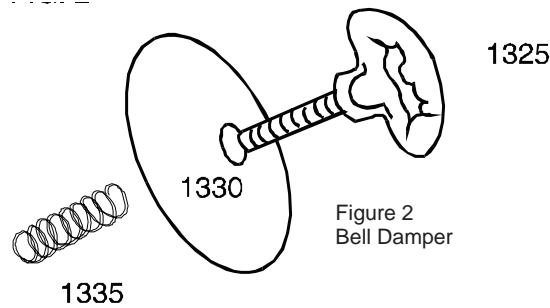

2. Insert a piece of 6" (15 cm) diameter black smoke pipe into the flu and secure with three sheet metal screws. (See page 14, "Stovepipe Chimney Connection Requirements")

Once the cabinet has been assembled and installed, follow these few remaining steps:

1. Insert the lift handle (#1361) through the bracket and bolt it through the hole in the cooking surface with the screw and locknut.

The handle should be able to pivot freely from this point. Tighten the nut securely, so it can't work loose under normal use.

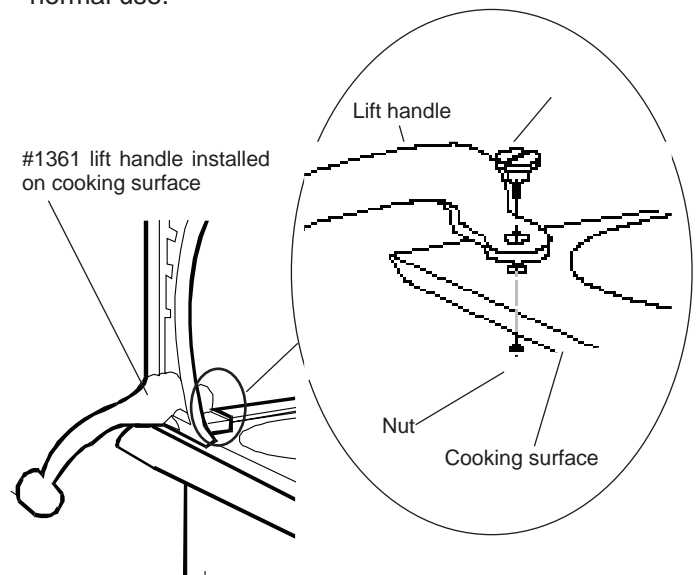

2. The tool holder (#1440) is used to hang the lid lifter, poker and scraper. To mount the holder, locate the two 1/4" (6.35 mm) holes on the firebox side of the warming cabinet back. Fasten with the bolts supplied.
3. A pipe damper installation is optional depending on your installation and chimney configuration. Your dealer can supply you with a damper.

The damper installation should be done before final assembly of the chimney.

- a) Open the front cabinet door.
- b) Mark the spot for drilling in the back of the pipe by pushing the sharp end of the damper rod into the back wall of the pipe before drilling.
- c) Drill a 1/4" (6.35 mm) hole in the middle of the smoke pipe through the centre of the hole in the back of the cabinet.
- d) Follow the instructions that came with the damper and install the damper inside the cabinet with the handle of the damper also inside the cabinet.
- e) Make sure the damper disc rotates freely inside the pipe.



---

# Installation

Be sure to read the sections on clearances, floor protection, and chimneys before actively starting the installation. **Contact local building or fire officials about restrictions and installation in your area.**

## Clearances

A woodburning stove radiates heat in all directions. Heat directed toward living areas in front of the stove is usually very welcome.

However, heat radiating in other directions will not be as welcome if it results in overheating nearby walls, ceilings and floors.

An important part of planning a safe installation is to be sure that combustible material located near your stove does not overheat.

Clearance is the distance between your stove and stovepipe and nearby walls, ceilings, and floors.

If there is adequate clearance, then the nearby surfaces will not overheat.

The clearance distance should be empty except for non-combustible heat shields.

Air flowing between the stove and stovepipe and nearby surfaces carries away heat.

Do not fill the empty space with any insulating material.

Be aware that as wood is exposed to continuous heat it dries out, eventually lowering the temperature at which it will start on fire.

Maintain the clearances outlined in this manual, particularly with respect to nearby combustible surfaces.

Your Heartland cookstove has been tested for safe operation providing that these guidelines are followed.

***Clearances must be maintained to all combustible material. These include doors, trim, furniture, drapes, newspapers and clothes.***

An optional heat shield kit is available for our woodstoves for reduced clearances. See page 14 on “**Heat Shield Kit**”

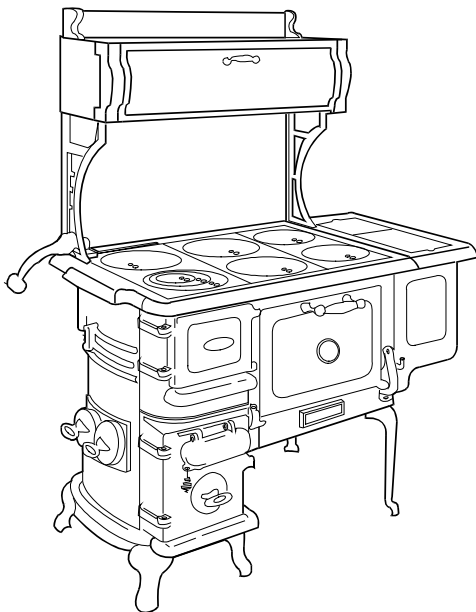

(Continued on page 10)

# Oval Rough in and Dimension Diagrams

These drawings are for reference only, showing approximate dimensions for rough in purposes. Make sure that no floor or ceiling supports will be cut due to chimney installation.

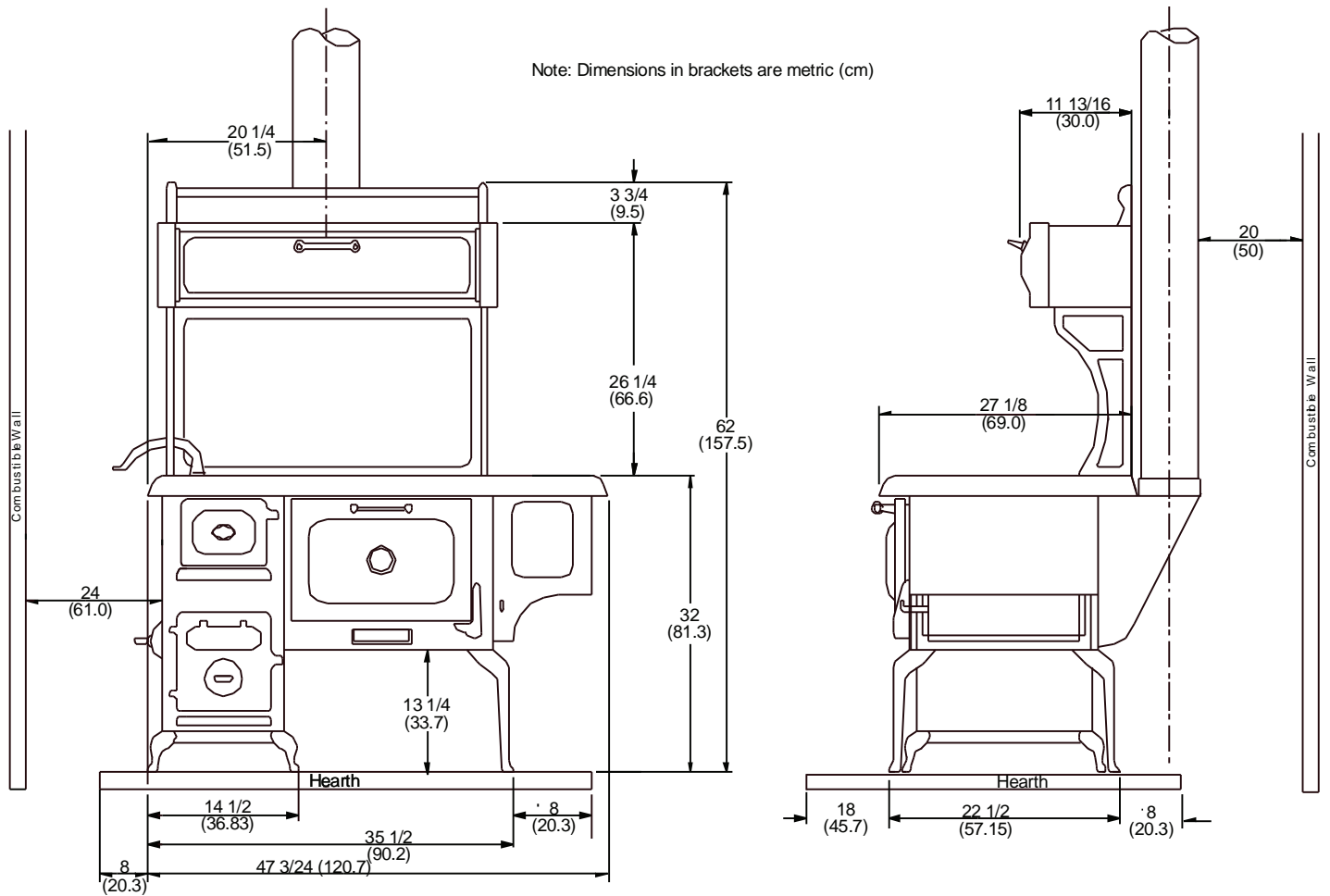
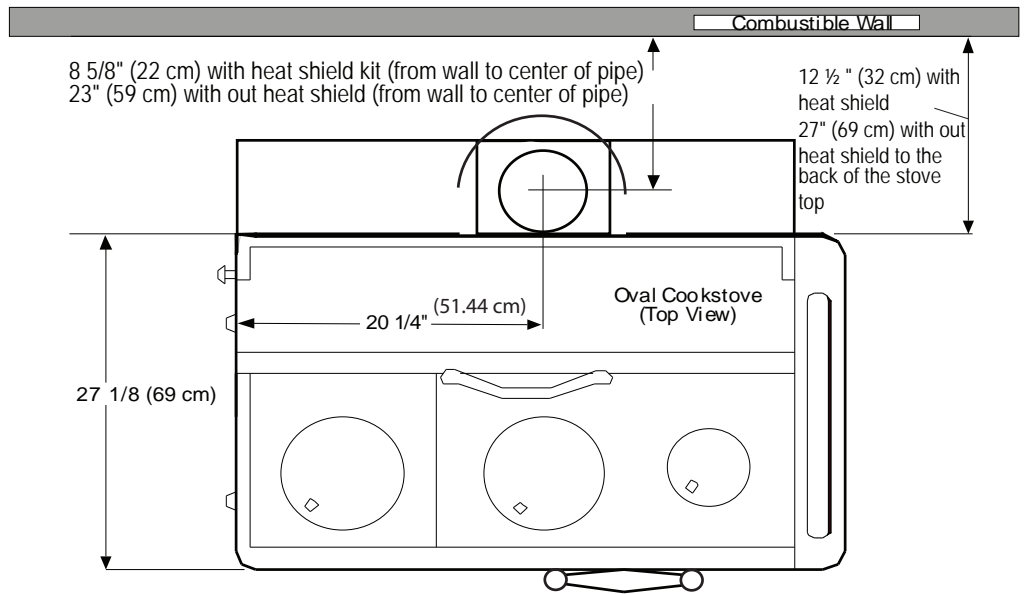

# SweetHeart Rough in and Dimension Diagrams

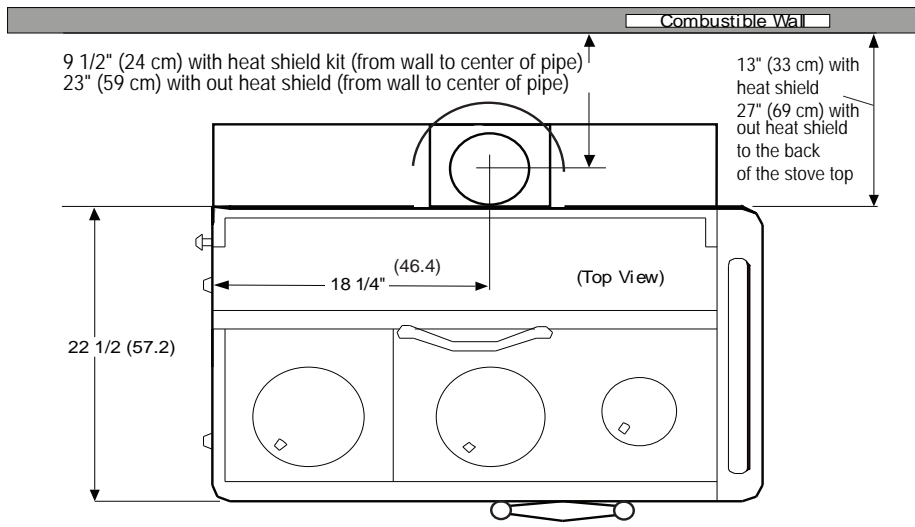

**These drawings are for reference only, showing approximate dimensions for rough in purposes. Make sure that no floor or ceiling supports will be cut due to chimney installation.**

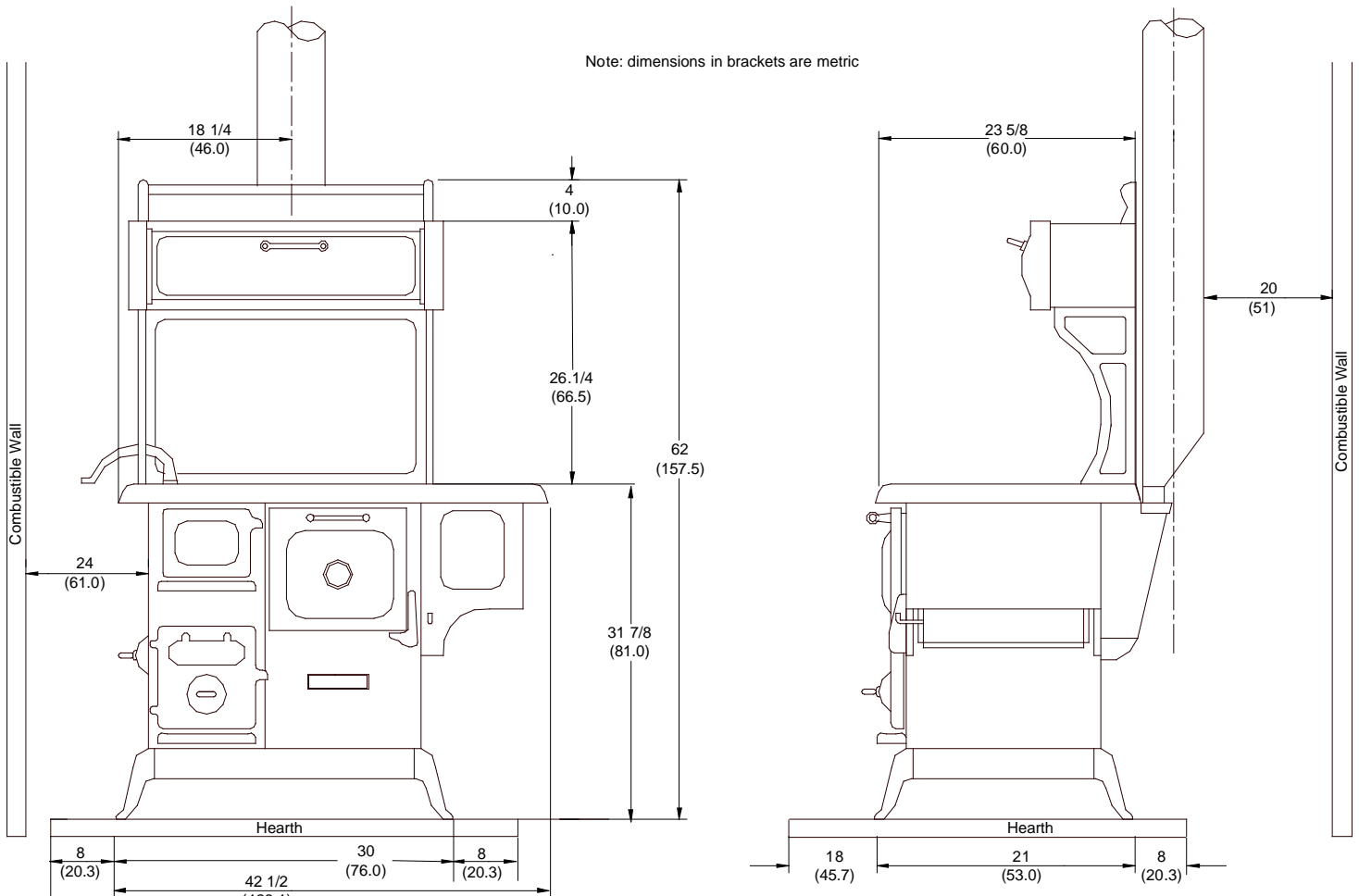

### Chart of Clearances

Status	Model	A	B	C	D	E	F	G	H	J	Measure
NO HEAT SHIELD	SweetHeart	25	69	66	66	50	58	132	61	121	Centimeters
		10	27	26	26	20	23	52	24	48	Inches
	Oval	25	68	66	91	50	86	132	61	121	Centimeters
		10	27	26	36	20	34	52	24	48	Inches
WITH HEAT SHIELD	SweetHeart	25	8	66	61	5	31	132	61	121	Centimeters
		10	3	26	24	2	12½	52	24	48	Inches
	Oval	25	8	66	91	5	44	132	61	121	Centimeters
		10	3	26	36	2	17½	52	24	48	Inches

**\*Note:** A chimney approved to ULC standard S629 in Canada or UL 103HT in the U.S. must be used to connect the smokepipe at the top of the cabinet to maintain the 2" (5.08cm) clearance to combustibles. The approved chimney must extend 1" (2.54cm) below the heatshield. PLEASE NOTE: That these are factory recommended clearances only, and are subject to local, provincial or state building and fire codes. These clearances may change without notice

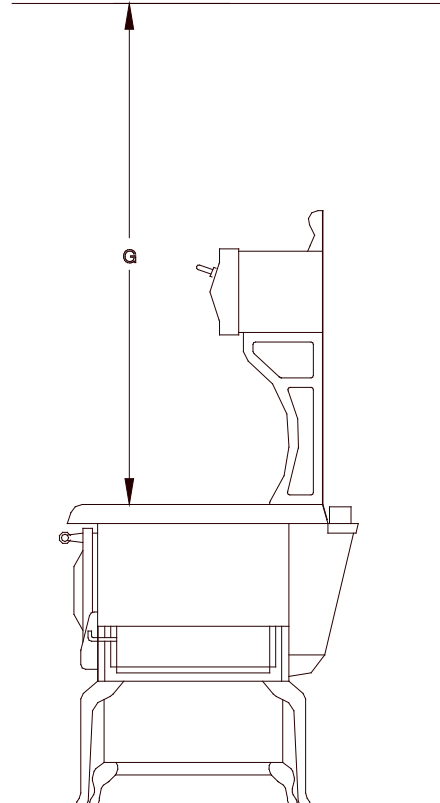
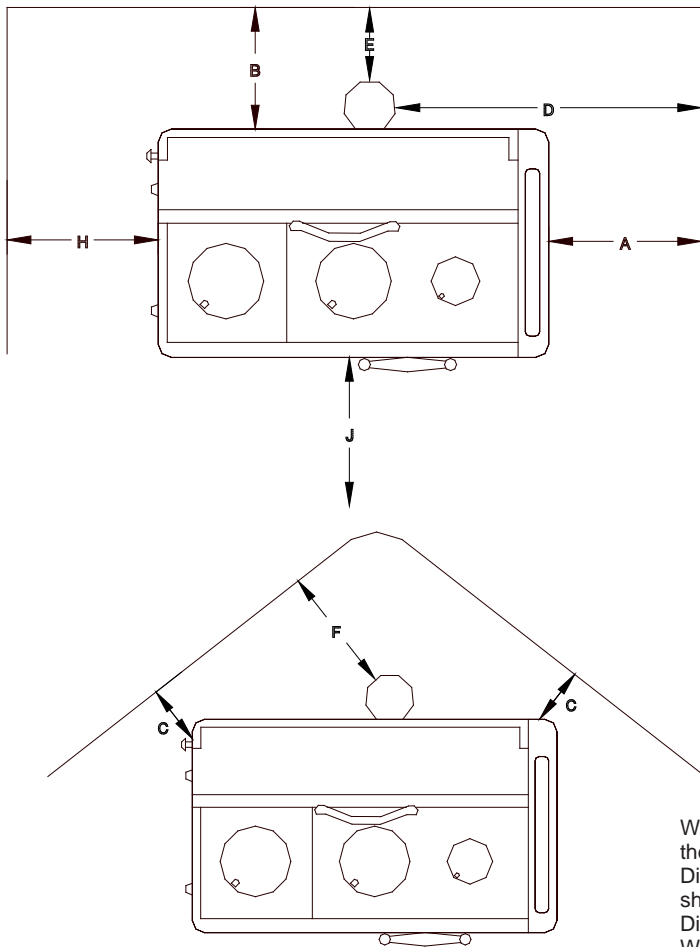

When a heat shield is installed dimensions B, D, E and F are taken from the heat shield.  
 Dimensions A, C, G, and H remain the same with or without a heat shield.  
 Dimensions A and C are taken from the *reservoir* on reservoir models.  
 When two or more clearances to combustible walls contradict each other, the clearance with the greater numerical value must be maintained.

# Chimneys and Draft

The chimney is the most important element of successful stove operation. (See also page 26 “Flue Pipes”)

## Performance of your woodburning system depends more on the chimney than on any other single component.

The chimney ‘drives’ the system by producing the draft that draws in combustion air and exhausts smoke and gases to outdoors.

When installing a new woodburning system or upgrading an existing one, give as much attention to the chimney as you do to the appliance that it serves.

The Oval and Sweetheart can be installed in a masonry chimney which is in compliance with the appropriate standard or a prefabricated chimney approved to **ULC Standard S629 in Canada and UL 103HT in the U.S.**

Follow the chimney manufacturer’s directions for installation. We recommend that prior to installing your stove into a masonry chimney, you have the chimney inspected by a qualified mason. An unlined masonry chimney should not be used without the installation of a liner.

The chimney and installation will have to be inspected by your local building inspector.

## Recommended Chimney Clearances

The chimney must: (see figure 3 below)

- extend at least 14 ft. (4.27m) above the collar of the stove;
- extend at least 3 ft. (92 cm) above the point where it passes through the roof;
- be at least 2 ft. above anything within a 10 ft. (3.048m) radius of the top of the pipe.

Good draft in a cold chimney should be between 0.01” and 0.15” “water column” (your dealer may be able to check this for you).

## Clearance Reductions

There are many alternate decorative methods to reduce clearances to combustible materials. See your dealer, or local fire or building official to ensure the appropriate standards are being met with these alternatives. In Canada, refer to the **Installation Code for Solid Fuel Appliances and Equipment. CAN3-B365-M84**. In the U.S., refer to the **National Fire Protection Association Standard 211**.

## Floor Protection

When installing your woodstove on a combustible floor, a non-combustible floor protector is required under the stove to protect the floor from hot embers that may fall when reloading. The floor pad must be a continuous, non-combustible pad (floor tile with grouting or a sheet metal pad). A floor pad should not be placed on top of a carpet. Pad must extend 21” (534mm) in front of the stove in Canada and 18” (458mm) in front of stove in U.S. Pad must extend 8” (203mm) to the sides and back of the stove.

Pad must extend fully to the wall if using side and back clearances less than these dimensions.

Pad extension must be fabricated from non-combustible materials: 1/2” (13mm) thick minimum with thermal conductivity factor “K” of 0.43 or lower (units of K = btu/h/F/in).

To determine thickness of equivalent material required use formula (“K” x 0.5) / 0.43 = thickness required (“K” value can be obtained from manufacturer of floor material).

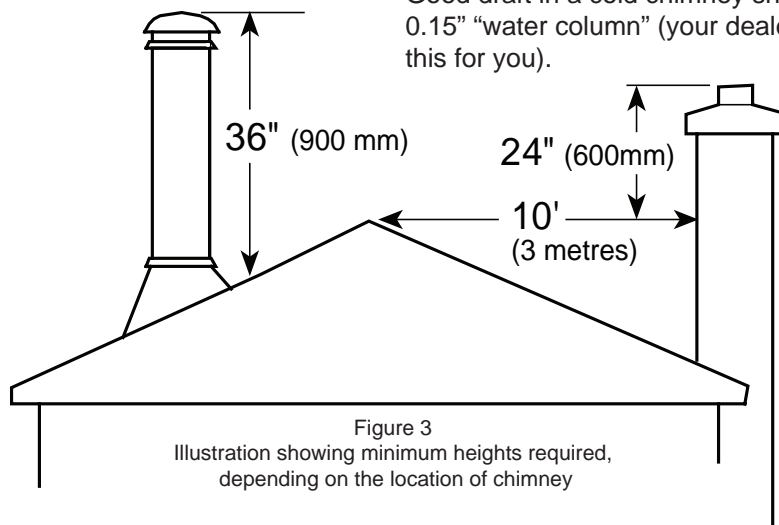

Figure 3  
Illustration showing minimum heights required,  
depending on the location of chimney

## Stovepipe Chimney Connection Requirements

1. The stovepipe chimney connector should be made of 24 gauge or thicker sheet metal and should be 6" in (15.24 cm) diameter.
2. The last section of the chimney connector starting from the stove should be screwed to the flue collar of the stove. Individual sections of the chimney connector must be screwed together with at least three sheet metal screws. The last section should be securely attached to the chimney. Be sure there are no "weak links" in the system.
3. The crimped ends of pipe sections should point downward toward the stove so that any soot or creosote that falls from the inside of the pipe will be funnelled into a clean out or fall into the stove.
4. The chimney connector should be at least the height of the warming cabinet before a 90 degree turn is installed, with no more than two 90 degree turns.
5. A horizontal run of stovepipe should be no longer than 4 ft (1.22m). A vertical run of stovepipe to a prefabricated metal chimney should be no longer than 8 ft (2.44m).
6. Do not pass the stovepipe chimney connector through a combustible wall if it can be avoided. If this cannot be avoided, follow the recommended in CSA B365 in Canada and NFPA 211 in the U.S., recommendation on Wall Pass-Throughs.
7. Do not use single wall smokepipe as an outside chimney.
8. Never pass stovepipe chimney connector through a combustible ceiling.
9. The whole chimney connector should be exposed and accessible for inspection and cleaning.
10. Galvanized stovepipe should not be used. When exposed to the temperatures reached by smoke and exhaust gases, galvanized pipe may release toxic fumes.
11. Horizontal runs of chimney connector should slope upward 1/4" (6.35 mm) per foot going from the stove toward the chimney.
12. During a chimney fire, the chimney connector may vibrate violently. The connector must be securely attached to the pipe and chimney, and individual sections must be securely attached together.
13. This stove is not to be connected to an air distribution duct.

## Optional Accessories

Accessories may be obtained from your dealer or call us direct at 800-223-3900. Our office hours are from 8:30 a.m. to 5:00 p.m. est

### Heat Shield Kit

A space saving heat shield kit enables you to install your cookstove as close as 2" (51mm) to a combustible wall!

### Installation is Easy

The heat shield kit is available for both Oval and Sweetheart cookstoves and mounts directly on the rear of the stove. The main section of the shield covers the firebox and oven of the cookstove, while the upper section covers the flu pipe to the height of the warming cabinet. (See illustration, Fig. 4.)

An installation and operating manual is packed with every Oval and Sweetheart heat shield kit. Extra copies may be obtained from your dealer or by contacting AGA Marvel.

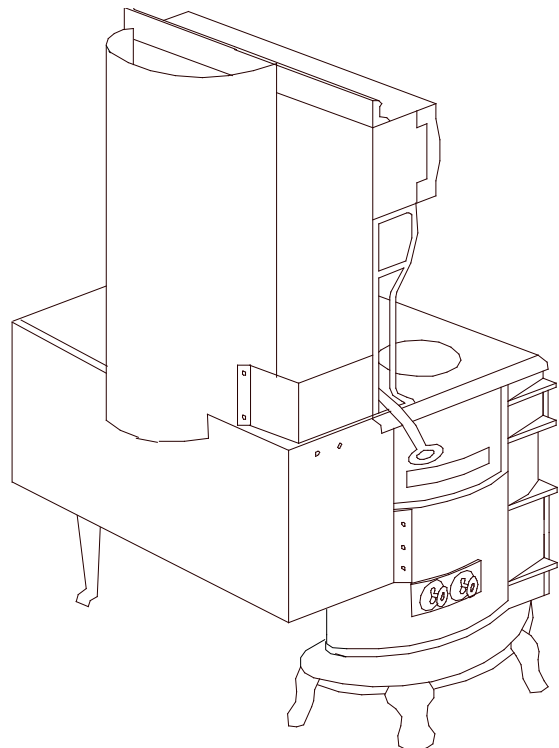

Figure 4  
Illustration of Oval with  
heat shield kit

## Fresh Air Kit

A fresh air kit enables you to use outside air, instead of room air to fuel the fire. Using an outside source for combustion air has its advantages. If your home is tight and well insulated, then the fire in the stove may be “starved” of combustible air, it will be difficult maintaining a fire, and you may have back drafting problems.

During the heating season, cold air, (which is more dense than warm air), will cause the fire to burn a little hotter, resulting in more BTU’s from your wood, and less creosote build-up.

Figure 5  
Illustration of Oval with  
fresh air kit

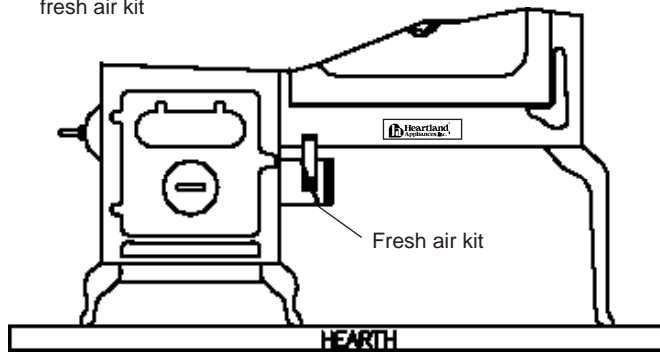

## Installation is Easy

Mounting holes and airways are all pre-punched on all new Oval and Sweetheart cookstoves. (See figure 5)

Simply remove the cover plates (right side of firebox on the Oval and, bottom of the firebox on Sweetheart). Now you are ready for installation. A complete set of diagrams and instructions are included with each fresh air kit.

Please note that some States require a fresh air source to be installed with wood burning appliances. Please check your local, and state, building codes.

## Water Jacket

The average family spent about one quarter of their utility bill to heat water last year. By installing the water jacket in your cookstove, you can reduce or virtually eliminate your hot water utility bill.

## Installation is Easy

The water jacket can be installed in the stove in less than a minute using only a slot screwdriver. The water jacket is a hollow baffled chamber that fits in the firebox. Two pipes and a pump installed from the water jacket to the electric or gas water heater, circulate heated water from the stove to the storage tank. (See illustration, Fig. 6.)

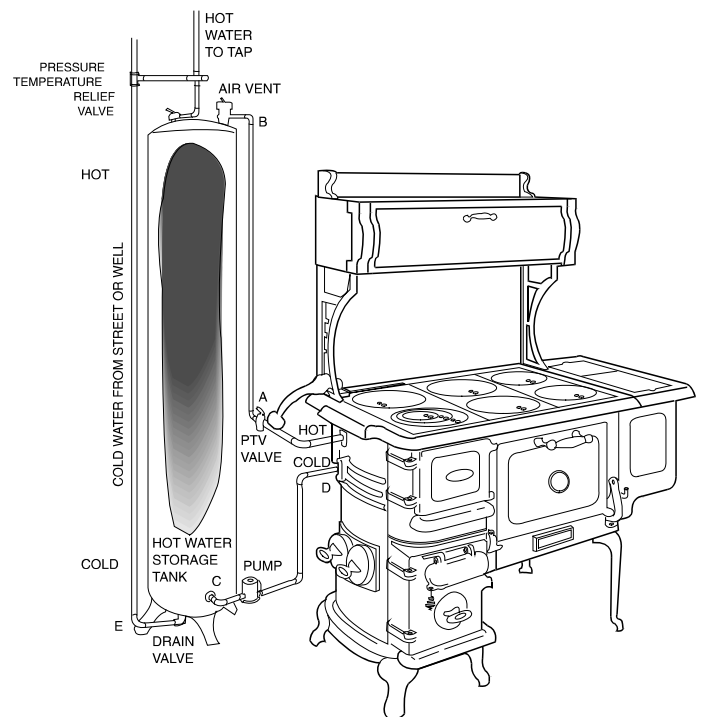

Figure 6  
A Sample Oval Water Jacket Installation  
This is an illustration of an active or pumped  
circulating hot water system.

You can expect from 8 to 10 gallons (30.3 to 37.9L) or more hot water per hour (about 10,000 BTUs) from your oval water jacket, OR 6 to 8 gallons (22.7 to 30.3L) (about 8,000 BTUs) from your Sweetheart water jacket.

Because cold water cools the water jacket in the firebox, creosote will be attracted to its cool surface, like humidity being attracted to a cold window. These deposits will quickly burn off thus reducing creosote formation in the stove and chimney.

An installation and operating manual is packed with every Oval and Sweetheart water jacket. Extra copies may be obtained from your dealer or by contacting AGA Marvel.



---

# Understanding Combustion

---

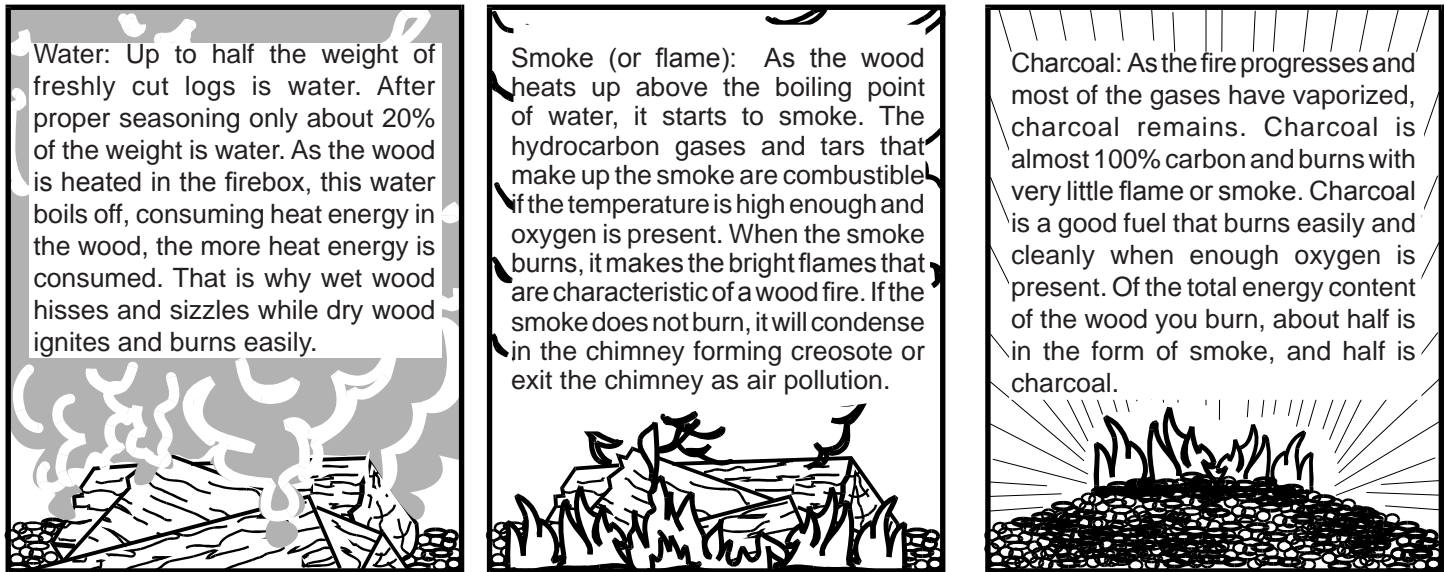

Figure 7

## Break-in Fires for New Stoves

If this is your first fire, OR you have installed a replacement set of brick, read the procedure for break-in fires. Proper seasoning ensures longer stove life.

## Fuel

### Woodburning

The firewood you use will make an important contribution to successful operation. You will achieve the best performance and overall efficiency by burning firewood that has been split, stacked and air-dried undercover from rain for at least one year. Burning improperly seasoned or “green” wood can be a frustrating experience leading to poor performance, smoky fires and a build-up of creosote. Do not burn saltwater driftwood refuse, rubber tires, etc. Use of improper fuels can cause a fire hazard and lead to a premature deterioration of the stove components, voiding the warranty. (See Fig. 7 Understanding Combustion.)

Burn dry wood because:

- it gives up to 25% higher efficiency;
- it produces less creosote;
- it ignites faster and smokes less;
- valuable heat is lost in the fire as it dries out wet wood.

## Getting Acquainted

The Sweetheart and Oval cookstove are time proven heating and cooking appliances. Take your time to acquaint yourself with the principles on which your new stove operates as a heater and cooking stove.

Understanding the primary principles of the air intake controls, the oven damper, the flame path for the fire and the relationship to the chimney will give you a very comprehensive understanding of what you are trying to accomplish with the stove.

Before starting the stove, lift the key plate handle and rest the arm in the top hook of the cabinet bracket. Open both the top loading and ash pan doors. The doors open by lifting slightly over the hook and pulling towards you. Always use the lid lifter to open doors and bell dampers and when adjusting the oven damper.

In the Oval, looking into the firebox through the top you see cast iron liners, these liners rest on an oval refractory firebrick.

In the Sweetheart, looking into the firebox through the top you will see firebrick liners on the left and right side of the firebox.

At the bottom of the firebox is the wood grate, looking in through the ash pan door, you will see the wood grate pull—slide it back and forth and looking down into the firebox you will see the slots open and close.

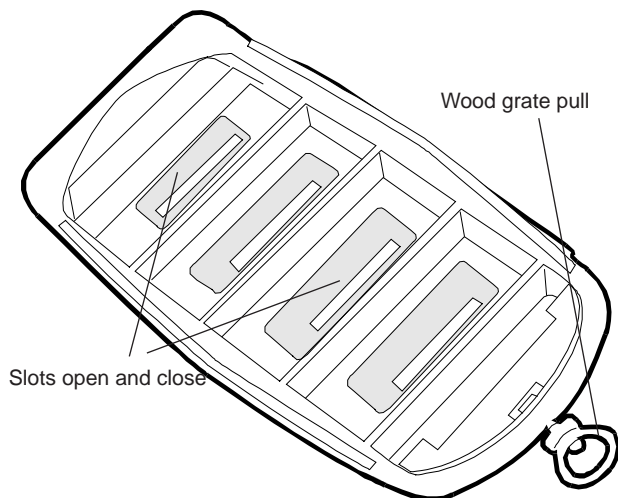

The stove is burned with the slots open which allows the combustion air to enter underneath the fire. As ash and coals build up on the grate these slots fill and will require the occasional "shaking".

It is a good policy to shake the grate or stir the coals with the poker before loading a new charge of wood.

You will notice that with the ash door closed the ash flap

may be lifted to access the wood grate pull without having to open the door.

Burning skid wood or construction materials with nails is not recommended as anything in the firebox that will not burn has the potential to get caught in the grate.

The ash pan is directly below the grate.

## Starting the Stove

### Good safety practices:

Educate your family members:

- before burning the stove, have each family member read this manual and be aware of safety practices;
- keep children, clothing and furniture away from the stove;
- the stove is HOT while in operation – DO NOT TOUCH the stove, contact may cause burns;
- open the fire door, ash pan door, woodgrate pull, bell dampers and oven damper with the 1415 lid lifter only—these surfaces get hot; (see figure 8)
- keep a fire extinguisher nearby and have a clearly understood plan on how to extinguish a fire.

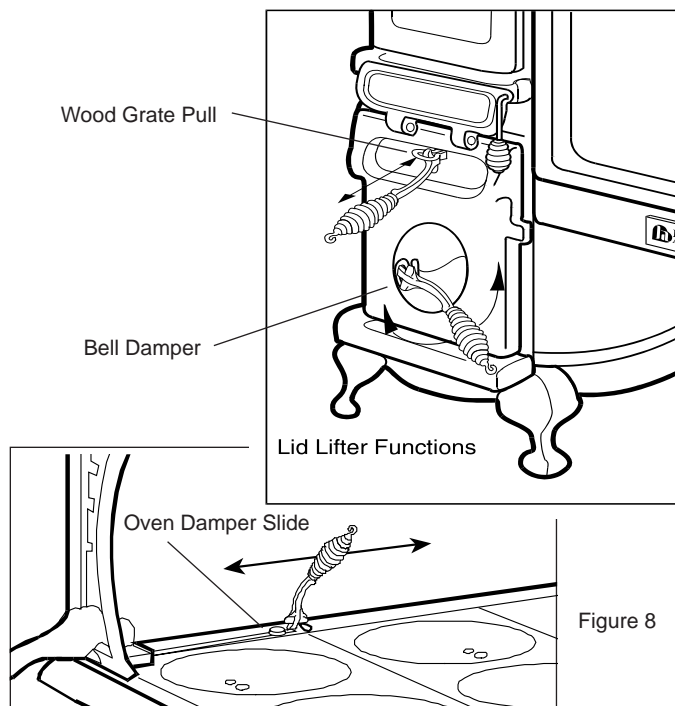

Figure 8

## Break-In Fire

(Refer to page 16 figure 7)

The firebox of your stove is made of superior materials—cast iron and firebrick lining.

Both materials could be broken by a sharp blow or thermal shock. A little extra care and thoughtfulness during the break-in period will help promote a long life for your stove.

The cast iron and firebrick will have picked up moisture during shipping and storage.

During the break-in period it is important to let the cast iron and firebrick slowly dry out and avoid thermal shock, caused by strong hot fires.

- Build a small kindling fire (following the instructions below for the first fire) and add small pieces of kindling. Let the stove burn for approximately one hour on the first firing.
- Let the stove cool keeping the doors closed.
- Repeat the process for a few days or until you have had six break-in fires. You may notice some smoke or “burnoff” during your initial firing. This is normal and is caused by the curing of the paint finish.

## Your First Fire

It is advisable to read and understand this section thoroughly before starting the fire (Refer to page 16 figure 7)

1. Open the oven damper (see Fig. 8 and 9) and air intake controls (bell dampers). On damp cold days, it may help to open the ash door slightly until a good draw develops in the chimney.
2. To kindle a fire. Lift the key plate lift handle and rest it in the top slot of the closet bracket. Crumple six to eight single sheets of newspaper into loose balls and place them on the wood grate. Cut 10-15 pieces of kindling into strips approximately 1/2” by 1/2” by 10” long (1.27 cm by 1.27 cm by 25.4 cm).

Place the kindling on the newspaper. Place 2 or 3 more pieces of crumpled newspaper on top of the kindling. Ensure that the wood grate slides are open.

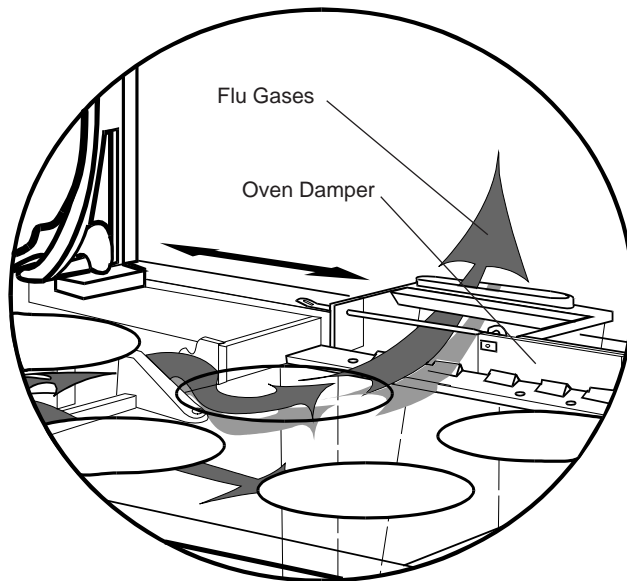

Figure 9 - shows oven damper open

Lighting the ‘charge’ is of your personal preference. One method is to roll a piece of newspaper into a torch, lighting one end and using it to start the paper.

Light the paper at the bottom of the load and then light the paper at the top, shut the key plate immediately. You may find it helps to hold the key plate open just slightly for a few seconds to give some extra air and establish the fire.

3. To Fuel the Fire. After a couple of minutes lift the key plate or open the front loading door slowly. When the kindling is established add larger pieces, perhaps 2”x2”x10” (5 cm by 5 cm by 25.4 cm) long.

Continue this process until the fire is established when split logs can be added.

Dampering the stove. Tighten the bell dampers to approximately 1/4” (6.35 mm) opening. This will slow the fire down. Wait momentarily and close the oven damper.

The smoke and heat is now being routed around the oven. Remember, by closing the oven damper resistance has been put on the system.

If the stove/chimney is not yet heated enough or there is too much volume of fire going through, this additional resistance will cause backpuffing.

Close the oven damper slowly (Fig. 9) to allow the oven flue chamber to absorb the smoke and heat.

4. Reloading the stove—Stove tending time will be greatly reduced if you reload your stove while the system is still hot and there is plenty of hot embers to rekindle the fire quickly. Including some smaller pieces of wood in the new fuel load will help the stove regain temperatures quickly.

When reloading, open the oven damper and wait momentarily—if loading from the top—slowly lift the key plate or if loading from the front, open the door slowly.

Load wood—smaller, split pieces first.

Close the door or key plate.

Open the bell dampers slightly.

The stove must rebuild its thermal momentum before closing the oven damper.

As you become more experienced you will gain knowledge on what settings of bell dampers and oven dampers can be used at the different stages of the woodburning cycle (see Combustion Process, page 16 figure 7).

## Summer Burning

Both Oval and Sweetheart stoves feature a utility which allows you to use your stove during the summer months with less heat radiating from the firebox.

### Oval:

1. Slide the wood grate from the lower firebox position and remove the wood grate slide.
2. Set the wood grate on top of the firebrick. You are now ready for summer cooking.

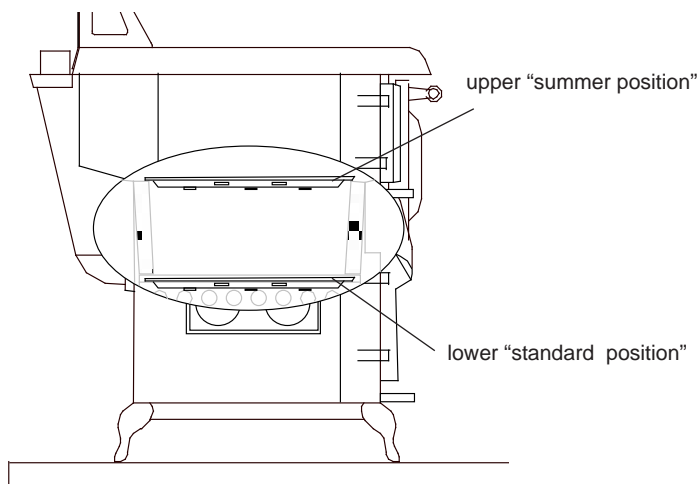

### Sweetheart:

To use the summer position in the SweetHeart you will need to purchase the optional #4271 summer grate support. Call your dealer to order, or call direct to AGA Marvel.

1. Remove the wood grate from the lower firebox position by pulling the grate up, back end first, and out of the firebox.
2. Remove the wood grate slide from the wood grate. Place the “summer position wood grate stand” at the back of the firebox on the firebox extension.
3. Place the fire grate so the back of the fire grate rests on the stand, and the front rests on the top of the front brick.

You are now ready for summer cooking.

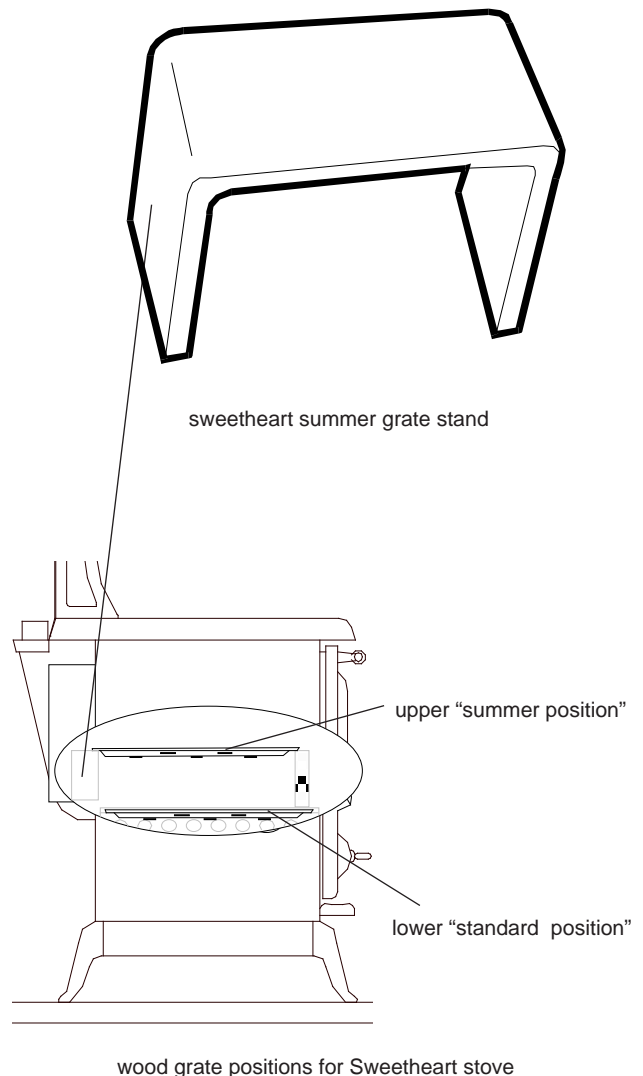

# Coal Burning

Do not burn coal on the wood grate. An **optional** coal grate kit is available for the Oval (#1500) and the SweetHeart (#4500) to burn coal. An installation and operating manual is packed with every Oval and Sweetheart Coal Kit. Extra copies may be obtained from your dealer or by contacting AGA Marvel. Below is a brief description of the coal kit installation

## Sweetheart Coal Grate Installation

To install the optional coal grates, remove the lift handle, the key plate and lids. Lift the wood grate out through the top of the firebox and replace it with the coal grate. Remove small front brick in firebox by unscrewing bolt & nut that holds brick in place. (Please note that older models require front fire brick to be installed with the groove facing away from the firebox and towards the front of the stove). Replace with large brick in coal kit. Gently tap the coal grate down until it fits snugly into the steel track. Replace the key plate, lift handle and lids. Then proceed with firedoor damper installation.

## Oval Coal Grate Installation

To install the optional coal grate package, remove the wood grate through the ash pan door and replace with the coal grate. Remove the key plate over the firebox and slide the coal liners #1470 in the front and #1475 in the back of the firebox. Replace the key plate, lift handle and lids. Then proceed with firedoor damper installation.

## Oval and Sweetheart Firedoor Damper

(Coal burning only, see illustration on next column)

The firedoor damper comes with each coal kit and must be installed. Remove the nickel firedoor frame from the firedoor. Loosen the three screws that hold the cover plate over the damper holes. Replace the cover plate with the coal damper, lettered side out. Tighten screws just enough to hold the damper plate on but also allow it to slide freely back and forth. Lock screws in position with a nut on each screw thread.

***A wood "break in" fire should be done before attempting to burn coal (see page 16).***

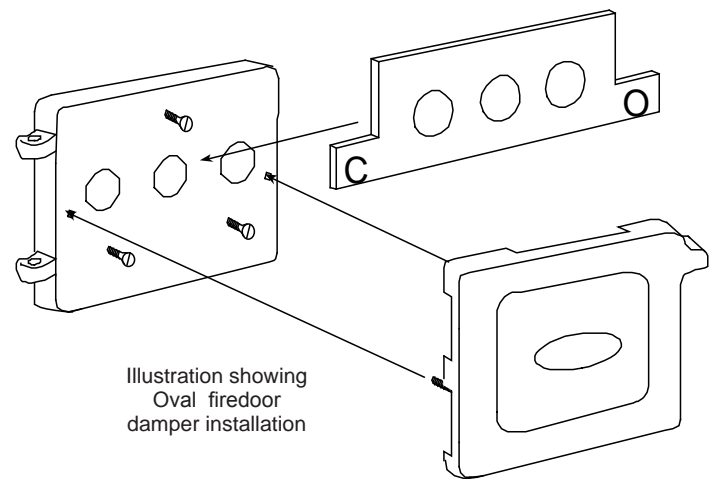

Illustration showing  
Oval firedoor  
damper installation

## Starting Up a Coal Fire

A chimney 6" (15.25 cm) in diameter is imperative for the Coal Burning process. On chimney larger than 6" (15.25 cm) in diameter will cause poor ignition of the coal due to inadequate draft.

It is possible to burn coal with a large diameter chimney, but banking a new bed of coals will require a greater mix of wood to create and maintain an adequate draft.

The minimum draft required to maintain an oven temperature of 350 °F (175°C) is around .04" (1.016 mm) on a water column. For drafts under .04" (1.016 mm) on a water column, closing the oven draft damper more than half way, will cause back puffing.

During the recharge phase of a new bank, a draft of .08" (2.03 mm) should be maintained for at least 10-15 minutes or until a substantial bed of red embers is built up.

We recommend burning anthracite coal, which is relatively clean to handle, burns evenly with a low flame, has a low sulphur content and produces relatively little smoke.

Use a "chess nut" or "nut" size of coal, which is 1 3/16 to 1 5/8 in (3 cm to 4.13 cm) diameter. However, other coal, such as bituminous, can be burned, but is inferior to anthracite.



## To Start a Coal Fire:

1. Use paper and dry wood kindling to start the fire.
2. Add small, compact pieces of hardwood when the kindling is burning hot. Keep the primary damper controls fully open to establish a hot fire quickly. The ash door also may be opened during start-up to accelerate the initial burn.
3. When a substantial bed of red embers is built up, start adding coal – small amounts at a time. Keep the draft control open.
4. Continue adding small amounts of coal until there is a solid bed of *burning* coal. Do not add too much at one time. Allow sufficient time between each small loading (at least five to ten minutes), so that each loading has time to ignite thoroughly before the next load is put in.

When a substantial bed of burning coals has been established, fill the stove to the highest possible level, no higher than the bottom of the firedoor – be careful not to overload! A deep bed of coal will always burn more satisfactorily than a shallow bed.

5. When most of the wood is burned and the coal is completely ignited (usually five to ten minutes or less after filling the stove), the draft control should be turned down to the proper operating level. (If the ash door has been opened, it *must* be closed to prevent overfiring, which can severely damage the stove.)

## Recharging the Fire

If the fire is burning hot and there is a deep bed of coals, add coal a hand full at a time.

Allow enough time between each addition for the combustion process to start. As the bank becomes larger, the amount of coal added at a time can be increased.

If the coal bed is under 5" (12.7cm) before a recharge is started, it may be necessary to add kindling wood to increase the combustion level so that more coal can be added.

1. Coal never should be added unless there is a reasonably hot fire. The coal bed should be bright and vigorous.
2. If the fire is burning hot and there is a deep bed of coals, full loads of coal can be added at any time. However, if there is not a deep bed of coals, it is best to add small amounts of coal at first.

**NOTE: When burning coal, the firedoor damper must be kept open. The secondary air is required to aid in burning off coal gases. The coal damper is not required when burning wood and should be kept closed when burning wood.**

**Coal grates are not to be used in upper (summer) position. Do NOT fill firebox with coal higher than the bottom of the firedoor opening.**

## Disposal of Ashes (wood and coal)

**Do not remove the ash pan when the stove is hot.** Carry the ash pan with one hand on the handle in the upright position and the other on the front handle to balance the pan.

Improper disposal of ashes is the most common cause of wood stove related fires.

Empty the ash pan before ashes build up over the top.

## Use Caution:

- **don't carry hot ashes through the house;**
- **even though the stove may be cool, the ashes in the pan may still be hot;**
- **never place the ash pan on a combustible floor;**
- **never leave the ashes near combustible material or combustible liquids;**
- **always dispose of ashes in a closed metal container with a tight fitting lid—if an unexpected gust of wind fan the ashes, a fire could result.**

# Using the Oven and Cooking Surface

## Stove top cooking

The cast iron top provides an excellent large cooking area for griddling, frying, basting and simmering.

Some users report griddling directly on the cooking surface, although this is not recommended, as it usually creates quite a mess. A cast iron cooking vessel with a flat bottom is recommended. As you inspect your new oval, you may find the edges of your keyplate sitting slightly above the cooking surface. This is caused by the stiff new gasket under the keyplate. As the gasket compresses over time, the keyplate will drop to a position even with the rest of the cooktop.

To allow for normal settling, we have purposely created a slight upward warp at the middle of your oval keyplate. As the keyplate heats and cools it will eventually settle to a flat position. The time period for settling will be different for each stove depending on usage. Please allow a full season of use as a minimum.

When getting used to cooking on the stove top remember that the surface is cast iron and like cast iron cookware, once heated retains the heat for a long time.

Successful stove top and oven cooking will not result from trying to fire the stove up immediately but by having a heated stove and 'banking' the fire to retain the temperature required.

The left hand side of the cookstove top will be the hottest as the fire burns directly beneath it. The surface will get cooler the further you go to the right.

The oven damper can be used to help control the heat on the cooking surface. To have the entire cooking surface warm, the damper will need to be in the closed position. This funnels the heat under the entire cooking surface, therefore heating it (see figure 10).

The temperatures established on both the cooking surface and in the oven are determined by three primary things:

1. The amount of draft the chimney has. As the bell dampers are opened more air gets in the firebox and is drawn through the stove and chimney, resulting in a faster, hotter fire.
2. The position of the oven damper. With the oven damper closed, the heat is channelled under the entire cooking surface (heating it up) and around the oven (heating it up). When the oven damper is open, the heat will be routed directly up the chimney.

How much wood/coal is in the firebox and what stage of the combustion process it is at.

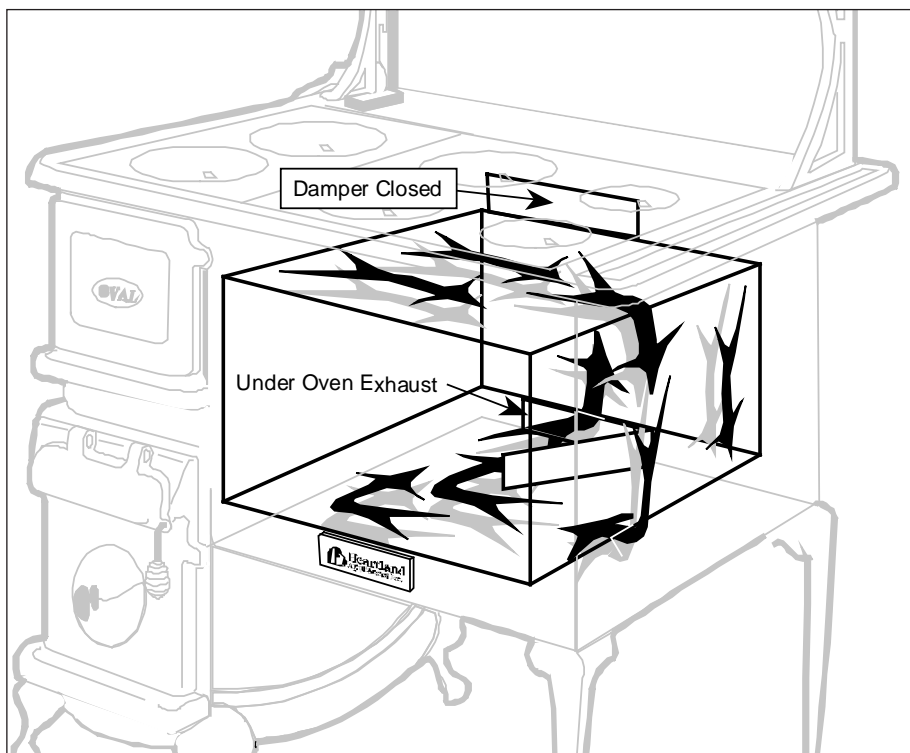

Figure 10



## Oven Cooking

Learning how to most effectively control the oven temperature takes some time and experience. As a general rule, the stove should be at the charcoal stage of the combustion process before the oven is ready for cooking.

**Important Note:** *The oven door thermometer registers the temperature at the door only. For accurate oven temperatures, refer to this interior oven thermometer.*

Ovens vary in temperature from top to bottom and side to

Rotate base for use as a hanger.

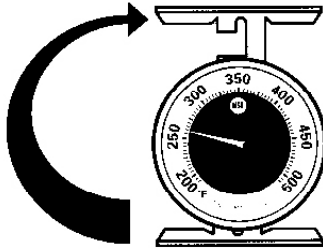

side. The only accurate check on oven temperature is an oven thermometer placed along side food being roasted or baked. See page 29 if your door thermometer needs adjustment.

1. You will find that once the stove has about 4" (10.16cm) of red hot coals in the firebox, it will have reached 'equilibrium'.
2. Equilibrium means that the entire stove and chimney system is heated and running at a fairly constant temperature.
3. At this point, you may load a new charge of wood following the procedure for 'reloading'. Allow the stove to regain its momentum—igniting the new charge. Keep bell dampers dampered down to allow a steady slow flame.
4. The oven temperature can be controlled by moving the oven damper slide. In the closed position, the oven will get warmer, and cooler when you open it.
5. Remember the effects of the changes in the damper position are not instantaneous on the oven temperature.

6. Ideally your stove will perform best if it is left running constantly, keeping the entire system warm. Depending on your wood and chimney conditions it would typically take three or four charges of cord wood to establish a good base for oven cooking, meaning 1 1/2 to 2 hours before cooking from a cold start.
7. Always load a new charge of wood to a glowing hot coal bed about 4" (10.16 cm) deep. Waiting too long to load a new charge means that the dampers will have to be opened, to get the new charge burning well. This results in extreme temperature swings and will make cooking difficult. Your objective is to maintain the coal bed and a constant heat.
8. Occasional 'tending' or stirring may be required. Keeping these principals in mind and with a little experience, you will find cooking to be easy and trouble-free.
9. Woodstove cooking methods are as diverse as their owners—there is no right or wrong way, only, in time, your way.
10. Remember by opening the oven damper there is less resistance on the flue and a hotter faster fire will result. The cooking surface directly over the firebox will typically get hotter in this configuration.
11. Always open the oven damper before opening any firebox doors or lifting the key plate. Wait momentarily before opening the doors to allow the smoke in the oven chamber to be drawn up the chimney to avoid backpuffing.

Maintain your stove properly. The benefits in superior performance and safety are well worth the time.

## Water Reservoir

This section pertains to the water holding tank on the side of the stove and applies only to reservoir models.

The reservoir has a porcelain enamel top and lid. The lid lifts open and will rest at an open position, or can be removed entirely.

The tank in the reservoir is made of copper, for easy cleaning and the seams are soldered with lead free solder. The tank has a 5 gallon (18.9L) capacity with a spigot mounted on the side, for easy access to the water.

Water must be added manually, the tank is not connected to your plumbing.

To route heat around the reservoir, open the reservoir damper (turn handle to the right). Vertical position of the handle means that the reservoir damper is closed, and no heat is passing under the copper tank. Horizontal position of the handle means that the reservoir damper is open and more heat is circulating under the copper tank.

The water in the reservoir can be heated from luke warm to boiling hot depending on how you are burning the stove, the position of the water reservoir and the oven dampers.

The reservoir damper is 'downstream' from the oven damper which means that if the oven damper is open, the flu gases are not circulating around the oven and therefore not past the reservoir either, so the water in the reservoir will not get as hot as when the oven damper is closed.

**Helpful Hint:** When lighting your stove from cold or when the stove is relatively cool remember the water in the reservoir will be at the same temperature.

The cold water will tend to absorb the heat that you are attempting to use to heat the chimney to start the stove. Close the reservoir damper during this period.

The same theory applies when heating the oven. If the water reservoir damper is open, the valuable heat you are trying to heat the oven with will be absorbed by the mass of cool water in the reservoir. Close the water reservoir damper during this period.

Woodstove heat is very dry and the water in the reservoir will add much needed moisture to your home. The warm water can be used for bathing, dishes or other clean up needs.

**Always ensure water is in the tank when the stove is in operation.** If the reservoir runs dry the soldering may melt away from the joints, resulting in leakage.

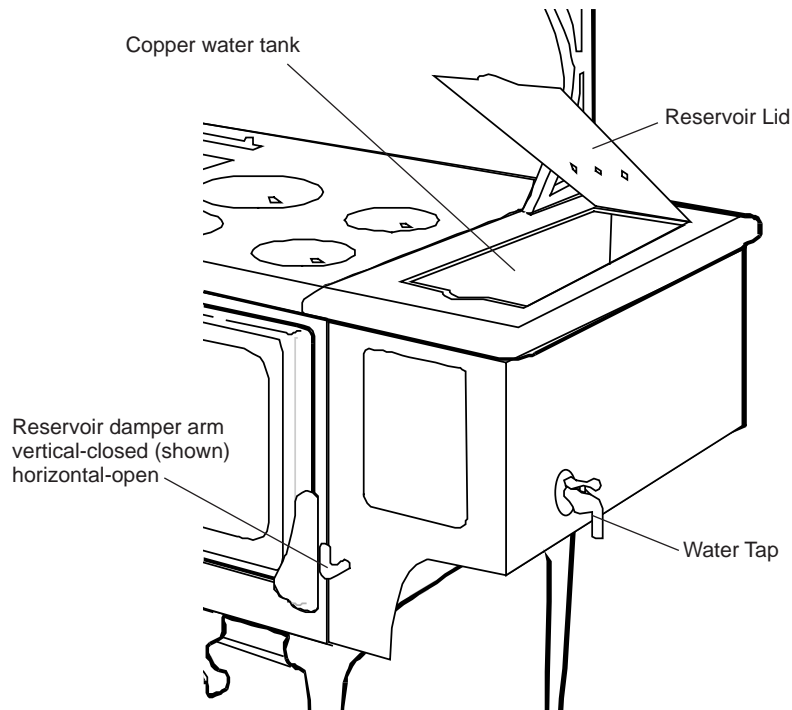

---

# Trouble Shooting

## Chimneys and Draft

The performance of your woodburning system depends more on the chimney than on any other single component. The chimney 'drives' the system by producing the draft that draws in combustion air and exhausts smoke and gases to outdoors. Give as much attention to the chimney as you do to the appliance that it serves.

## How Chimneys Work

It is well known that hot air rises. This principle is at work inside chimneys and is the key to understanding how chimneys function.

The hot exhaust gases from the appliance are lighter than the outside air. This buoyancy causes the gases to rise in the chimney. As they rise, a slight negative pressure is created inside the appliance. Air rushes into the appliance through any available openings to balance this negative pressure.

The force caused by the rising gases is called draft. Draft is created by the difference in temperature between the gases in the chimney and the outside air. Greater temperature differences produce stronger draft.

## Factors That Affect Draft

There are several factors that interfere with draft and most woodburning systems have one or more of these features. It is usually a combination of conditions that make a chimney fail to function properly.

Here are the main factors that influence draft:

### Cold Chimney Liner

An uninsulated chimney that runs up the outside of a house and is exposed on three sides is chilled by outside cold. This means that the flue gases give up their heat rapidly to the liner. As they cool, they lose their buoyancy and draft is reduced. Insulation between the liner and the chimney shell can help to reduce the heat loss, but a chimney that is enclosed within the house is preferable.

### Large Liner

Chimney liners that are much larger than the flue collar of the appliance allow flue gases to move too slowly. This slow movement gives the gases more time to cool and lose their buoyancy. Oversized liners are the reason that many fireplace inserts vented through fireplace chimneys tend to perform poorly. Ideally, the liner should have the same internal area as the flue collar of the appliance.

### Chimney Height

Taller chimneys tend to produce stronger draft. We recommend that the top of the chimney should be at least 36" (900 mm) higher than the highest point at which it contacts the roof and 24" (600 mm) higher than any roofline or obstacle within a horizontal distance of ten feet (three metres). These figures produce the minimum allowable chimney height. Chimneys higher than this are often needed for performance reasons. A chimney serving a cookstove located on the main floor of a single-storey house or cottage may not be tall enough to perform well, even though the minimum heights in the building code have been followed. A good rule of thumb to use states that the top of the chimney should be at least 16 feet (4.9 metres) higher than the floor on which the cookstove sits.

### Negative Pressure in the House

The draft produced by chimneys is a weak force that can be influenced by pressures inside the house. A woodburning cookstove acts as an exhaust ventilator by removing air for combustion from the house. A typical house may have several other exhausts, clothes dryer, gas or oil furnace, fireplace, or central vacuum system. When one or more of these other exhaust ventilators is running, it may compete for the same air that the woodburning appliance needs for combustion. This competition for air supply can make a fire slow to kindle or cause a stove to smoke when its door is opened. Chimneys are often blamed for this type of performance.

### Stack Effect in houses

In winter, the air in houses is much warmer and, therefore, more buoyant than the outside air. The warm air in the house tends to rise, creating slightly negative pressure in the basement and slightly positive pressure at higher levels. This negative pressure in the basement can compete with chimney draft to a stove or furnace located there.

## CHECKING AN EXISTING CHIMNEY

Before an existing chimney is used to vent your new cookstove, a thorough inspection should be done to determine its suitability. The inspection should be performed by an experienced professional because of the many factors that must be considered. A reputable chimney sweep or retailer can give you good advice on the suitability of an existing chimney.

Masonry chimneys should be checked for deterioration including damaged bricks, crumbling and missing mortar, cracks in the drip cap at the top of the chimney, and loose flashings at the roof line. The liner should be checked for cracks and misalignment, and its size should be 6" (15.24 cm).

An existing factory-built metal chimney needs a careful inspection. Your new cookstove should be connected only to factory-built chimneys approved to ULC Standard S629 in Canada and UL 103HT in the U.S. Possible problems with an older metal chimney can include a warped or buckled liner caused by the heat of a chimney fire, corrosion of the outer shell, a loose flashing, and a lack of proper support. Any discoloration of the metal shell near a joint indicates that the insulation has settled. A damaged metal chimney should be replaced with a new approved chimney which will be safer and will perform better.

## Safety Practices

### What To Do If You Have a Chimney Fire

- 1) Close all the combustion air dampers on the appliance.
- 2) **Call the fire department immediately.**
- 3) Be prepared to get everyone out of the house in case the fire spreads.
- 4) Go outside and check to see that hot ashes do not ignite shingles.
- 5) Watch anything near the chimney that could catch fire and burn.
- 6) After the fire has run its course and the chimney has cooled, **have the chimney thoroughly inspected to determine if it sustained any damage.**
- 7) Resolve to inspect and clean the chimney more often to prevent another chimney fire.

### Flue Pipes

Flue pipes carry the exhaust gases from the appliance flue collar to the chimney. The flue pipe assembly is an extremely important part of a woodburning systems and should be carefully planned and installed.

Here is a checklist to follow when installing or checking a flue pipe assembly. It is based on the requirements found in the Canadian Standards Association's Installation Code for Solid Fuel Burning Appliances and Equipment (Standard B365).

- 1) Single-wall flue pipe assemblies must not exceed 3 metres (10') in overall length.
- 2) The assembly should be as short and direct as possible.
- 3) A single-wall flue pipe assembly must have no more than two 90 degree elbows; use 45 degree elbow, wherever possible.
- 4) Do not use galvanized flue pipe because the coating can vaporize at high temperatures, emitting poisonous gases and leaving the pipe thin and weak.
- 5) Flue pipes for woodburning appliances need to be thicker than those used for other fire-burning appliances; 24 gauge for 150 mm (6") .
- 6) Joints between pipes should overlap at least 30mm (1 1/4").
- 7) Each joint should be secured with three sheet metal screws.
- 8) The assembly should be constructed to allow for expansion. Elbows in an assembly allow it to expand; straight flue pipe assemblies should have one section left unscrewed and secured with an inspection wrap clamped around the joint.
- 9) The pipes should slope up towards the chimney at least 20 mm/metre (1/4 in/ft).
- 10) One end of the flue pipe assembly must be securely fastened to the flue collar of the appliance and the other end fastened to the chimney.
- 11) There must be provision for the cleaning and inspection of the pipes by removal of the pipe. The removal of the pipes should not require moving the appliance.
- 12) The crimped ends of the pipes should point towards the appliance so that condensation drains to the appliance and does not leak out.
- 13) A flue pipe must never pass through a combustible floor or ceiling, or through a concealed attic, roof space, or closet.

Flue pipe assemblies should be stable and secure. To check the stability of a flue pipe assembly, grasp it at its mid-point and give it a good shake. If it is properly constructed, it will have little or no movement.

# Maintenance

## Oven Flue Passage

As heat, smoke and gases travel around the oven, fly ash and often creosote are left behind. The frequency of cleaning of the oven flue will depend on your use, burning habits and the wood you burn. If a 'fly ash' which is very fine and light in colour, is what is left behind in the oven flue chamber, it is a good indication you are burning your stove well.

If a sticky black ash is what you observe, you are burning wood which is too wet or the stove is not burning hot enough as a result of a poor chimney. Your dealer can help you correct this.

Follow this procedure when cleaning around the flue passage:

- 1) Clean the oven flue chamber by removing the top lids and scraping the ash to the sides.
- 2) Then scrape the sides so the ash falls to the bottom.
- 3) All the ash may then be scraped into a metal container through the ash cleanout door with the ash scraper.
- 4) Follow the procedure for ash disposal when cleaning the oven flue chamber, and chimney connector system.

Creosote buildup in the oven flue chamber can lead to rusting, a bad odour, and chimney fires. Check for creosote regularly and clean it out upon discovery. **Caution:** The water reservoir is a naturally cooler area of your stove, so creosote and fly ash **will** tend to build up on and around that side of the stove. Because of the potential for blockage and or ignition of the creosote, **frequent inspection of this area is very critical and clean out must be performed more often.**

Creosote is a tell tale condition of burning wet wood, a practice which should immediately be discontinued.

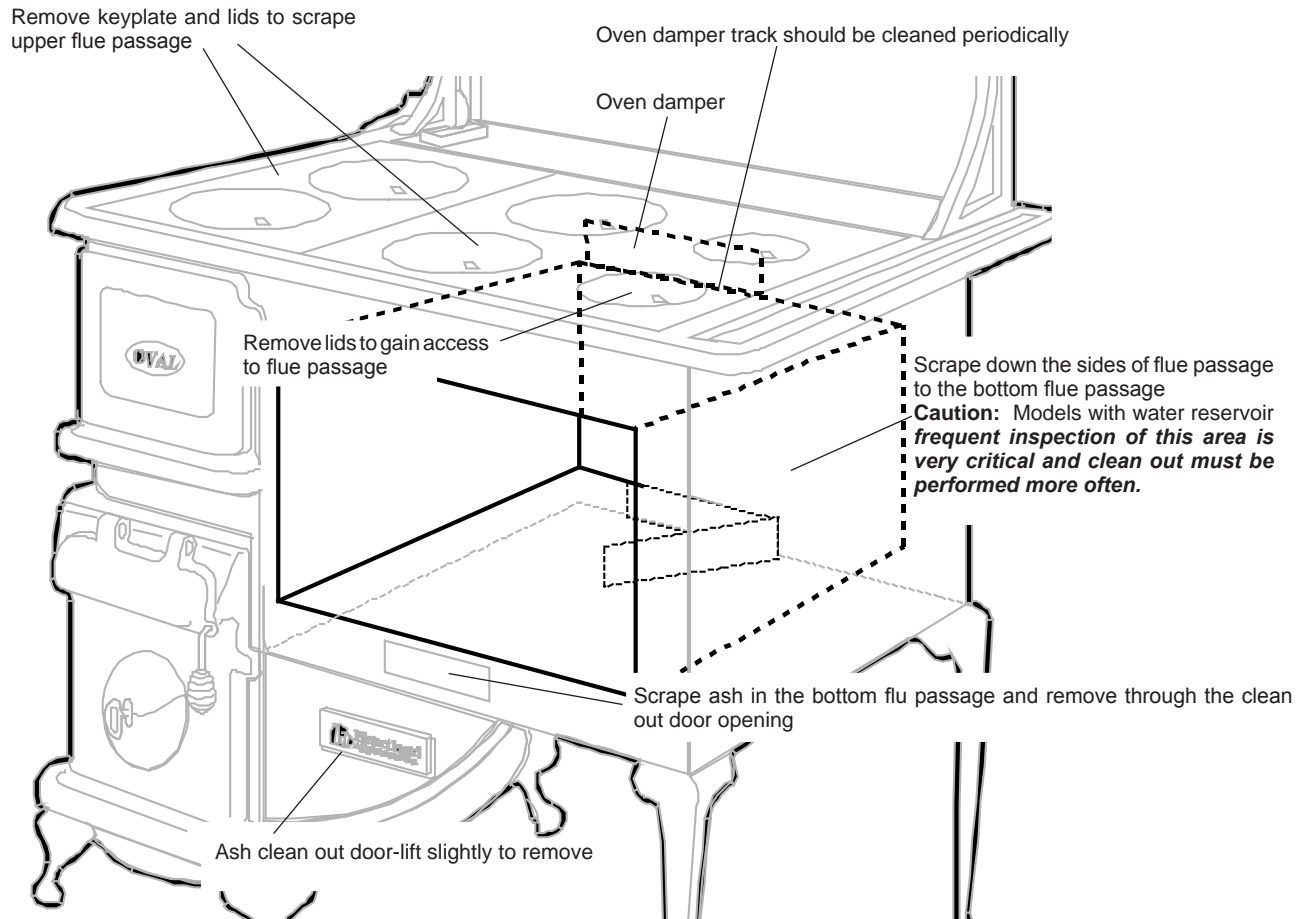



---

## Flue Boot Inspection

Remove the cover plate on the flue boot, located at the back of the range. Inspect for soot or creosote buildup, scrape and clean as much as possible, and remove debris through the clean out door with the ash scraper.

## Oven Damper

The oven damper may stick from time to time because of a buildup of ashes or creosote in the damper track. To free up the damper, scrape out the buildup or spray with a creosote remover, let sit for about 1/2 hour and clean out debris. (Caution: Never use any remover or cleaner on a hot stove.)

## Chimney Maintenance

Chimney serving woodburning appliances must be checked regularly for creosote build-up. The rate of build-up depends on cookstove and chimney characteristics, the type of fuel used, and on how the system is operated.

Until you are familiar with the rate of creosote build-up in the system, check it often - every couple of weeks. Well-designed woodburning systems tend to have a slower rate of build-up in the spring and fall when heat demand, and therefore firing rate, is lower.

Creosote may be in the form of dry, flaky deposits clinging to the liner, or a shiny, glazed coating that looks like black paint.

Glazed creosote is the most dangerous kind and indicates that one or a combination of conditions exist in the system that can cause the deposits;

- 1) a cold liner
- 2) smouldering fires
- 3) wet wood

Glazed creosote should never be allowed to exceed 1/8"(3 mm ) in thickness, Dry, flaky creosote should be removed when it reaches 6 mm (1/4") in thickness.

## Chimney Cleaning Equipment

Brushes and rods are the most common chimney cleaning equipment. Plastic brushes are normally used in metal chimneys and steel brushes are used for masonry chimney. The brush should fit snugly in the chimney so that enough friction is produced to remove deposits. Most chimney cleaning rods are made from fiberglass with threaded couplings at each end. Several passes with the brush are needed for a thorough cleaning.

Many homeowners prefer to contact the services of a chimney sweep rather than climbing on their roofs to clean the chimney. An experienced chimney sweep can complete the job quickly and will leave no mess behind. The sweep will also report

on the condition of the chimney. Referrals are the best way to select a chimney sweep. Check with your neighbours to see if they are satisfied with the sweeping services they have received.

## Cooking Surface

After the initial firing, your stove top will start to turn colour. This is normal and eventually the stove top will have a uniform blue finish.

The stove tops and lids are highly polished untreated cast iron. **To minimize the potential for permanent stains, always maintain the top with cooking oil. During periods of heavy use, a light coating is sufficient. When you will not be using the stove for a week or more, give the top a heavier coat and re-apply as needed. Always remove food, water or rust stains as quickly as possible. If such stains are left unattended, a permanent mark can result. To help remove stains, use a medium/fine aluminium oxide abrasive sanding block, available at most hardware stores, or a metal cleaner such as Flitz, in conjunction with fine (000) steel wool. Do not be afraid to use elbow grease.**

Stove top and/or keyplate may expand during heating and use - this is normal and slight gaps may appear around key plate. The natural expansion and contraction of the keyplate during heating is not unusual.

At the end of the heating season, especially in a seasonal location, apply a coat of cooking oil to keep the top from rusting.

***Please note - Owners of SweetHeart Cookstove: There is an expansion joint at the rear of the cooking surface on the firebox side. The purpose of this joint is to allow the top to expand and contract as required.***

## Nickel Trim

Nickel trim must be cleaned with warm soapy water and a micro cloth

## Porcelain

Never clean porcelain while the stove is hot. Porcelain is glass and sudden changes in temperature may cause cracking. Clean porcelain surfaces with glass cleaner or polish and a soft cloth. Oven stains may be removed with household oven cleaner.

Please Note: The spilling of acids like vinegar or lemon juice on the porcelain reservoir could leave a permanent stain.

## Door Gaskets

The rope gasket around the oven door, fire door, ash pan door and ash door flap, should be periodically inspected for a good seal.

If the gasket comes loose but is still usable, it can be reseated using a good high temperature silicon. Replacement gasketing and adhesive can be ordered from Heartland or your dealer.

Gasketing is sold by the foot. Refer to the gasket listing below.

### SweetHeart:

oven door - 4 ft #6387 rope gasket  
fire door - 3 ft #1710 rope gasket  
ash door - 3 ft #1710 rope gasket  
ash door flap - 2 ft #1710 rope gasket  
key plate gasket - 5 ft #1711 rope gasket

### Oval:

oven door - 4 ft #6387 rope gasket  
fire door - 3 ft #1710 rope gasket  
ash door - 4 ft #1710 rope gasket  
ash door flap - 2 ft #1710 rope gasket  
key plate gasket - 6 ft #1711 rope gasket

## Firebox

Periodic cleaning and inspection of the firebox is recommended.

On the SweetHeart and Oval cookstove there is a gasket on the top under the keyplate. This gasket should be inspected and replaced if it fails to seal.

Check for condition of side castings (Oval only) and smooth operation of wood grate.

Some cracking of the firebrick is normal and may be sealed with stove cement.

The firebrick, grate and cast liners are replaceable parts. You will prolong the life of these parts by:

1. Following the procedure for break in fires;
2. Avoiding impacting these parts when loading firewood;
3. Burning seasoned firewood.

## Oven Thermometer Adjustment

The temperature registered by the oven door thermometer may not necessarily correspond with the reading taken with the thermometer inside the oven. *For accurate oven temperatures, refer to the interior oven thermometer.*

An adjustment\* can be made to the oven door thermometer to allow a more representative temperature reading (most thermometers are adjusted to provide accurate readings in the 300F to 400F (150C to 205C) temperature range). After the adjustment, the low and high end of the temperature spectrum will not be accurate. To make temperature adjustments please follow the instructions below:

\* This adjustment may not be available on your unit.

- 1) Begin by removing the screws on the inside oven door panel. Remove panel.

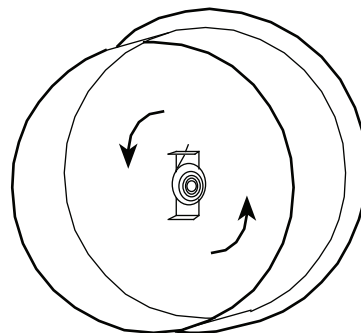

Rear view of Thermometer Figure 11

- 2) The back of the thermometer is exposed ready for adjustment (see figure 11)
- 3) With fine nose pliers, adjust the "L" bracket of the thermometer, moving indicator needle to desired position.
- 4) Replace the oven door panel and screws.
- 5) Re-test thermometer and adjust again if necessary.



---

# Terms of Reference and Function

**Backdrafting**—The emission of smoke and/or air through the stove when a flow reversal occurs in the chimney, caused by wind conditions or negative pressure within the building.

**Backpuffing**—The momentary emission of smoke through openings in the stove when oxygen is admitted to an oxygen-starved fire. When a door or the bell dampers are opened, the sudden charge of air may not be immediately absorbed by the chimney system, resulting in a backpuff of smoke.

To help eliminate this problem ensure that the oven damper is open before opening the ash pan or firedoor. Open the doors slowly to allow the smoke to clear from the chimney system.

**Bank (the fire)**—Loading the firebox with fuel (wood or coal) to produce a long burn cycle. Banking can only be accomplished on a good bed of coals.

**Creosote**—When wood is burned slowly, it produces tar and organic vapours, which combine with expelled moisture to form creosote.

Creosote vapours condense in the relatively cool chimney flue of a slow burning fire resulting in creosote residue accumulating on the flue lining. When ignited, this creosote makes an extremely hot fire.

Establish a routine for the fuel, wood burning and firing technique. Check daily for creosote buildup in the pipe and chimney until experience shows how often you need to clean to be safe.

The hotter the fire and/or the drier the wood, the less creosote is deposited. We recommend burning your stove with all the combustion air dampers open for at least an hour each day.

Weekly cleaning may be necessary in mild weather; monthly cleaning may be enough in the coldest months.

**Key Plate**—The cast iron section on the stove top which is lifted for fuel loading or to make repairs in the firebox.

**Key Plate Lift Handle**—The handle used to lift the key plate to allow access to load the firebox.

**Lid**—The removable round cast iron disks on the stove top. Can be removed to allow access to clean the flue chamber above the oven.

**Lid Lifter**—The tool used to remove the lids, open and close the firebox doors, and adjust the bell and oven dampers (see figure 8).

**Oven Cleanout Door**—The door under the oven that is removable to allow access to scrape ashes out of the flue passage around the oven.

**Oven Damper**—The shutoff for routing the heat smoke and

gases either directly out through the flue or around the oven.

When **'open'** the smoke, heat and gases will exhaust directly out the flue. This is the position used during the initial firing of the stove.

When **'closed'** the smoke, heat and gases will be routed around the oven heating the oven, cooking surface and more of the stove mass. When the oven damper is **'closed'** more resistance is put on the chimney system.

Opening any doors or lifting the key plate with the oven damper closed will result in backpuffing. Always open the oven damper before opening the ash pan door, firedoor or key plate.

**Oven Flue Passage**—The air space around the oven (between the oven top and the cooking surface, the right side of the oven and the right side of the stove, and the bottom of the stove and bottom of the oven) through which heat, smoke and gases travel.

This resulting travel heats the oven when the oven damper is in the **'closed'** position.

**Oven Rake**—The tool used to scrape creosote and ash from the flue chamber around the oven.

**Warming Cabinet**—The storage and warming area mounted to the base of the stove. Provides overhead storage and warming for plates and foods. May also be referred to as warming closet.

**Water Jacket**—A hollow collector which is installed in the firebox through which water flows is heated and is circulated to a storage tank, either by convection flow or by a small pump.

This system may be used for domestic hot water or baseboard heating. Installation should be carried out only by a qualified plumber. Ask your dealer, or call or write us for an installation guide.

**Water Reservoir**—The water holding tank on the side of the stove. Water must be added manually. The tank is not connected to your plumbing.

Woodstove heat is very dry and the water in the reservoir will add much needed moisture to your home. The warm water can be used for dishes and other clean up needs.

---

---

# Overfiring — Caution!

Overfiring of your woodburning appliance represents a serious fire hazard.

*Overfiring can also warp your stove, break welds, permanently discolour the plating and cause premature burnout of your stove. Repeated overfirings will void the warranty of this appliance.*

## To prevent overfiring:

1. If the air intake has little effect on dampening the fire, excessive chimney draft is the probable cause (especially on chimneys in excess of 20' or 6.1m). Normal chimney draft is approximately 0.05" (1.27 mm). Install a smoke pipe damper in the pipe approximately 5' (1.52m) from the floor. NOTE: Open damper before opening door to prevent smoking.

2. Install a magnetic thermometer on the top of your stove near the flue collar or a probe-type thermometer in the smoke pipe.

*To prevent creosote buildup in the pipes, the stove should be run between 800°F and 900°F (426.7°C and 482.2°C) for 30-45 minutes each burning day.*

3. Except for the initial period after lighting (5-10 minutes), do not operate your stove with the door open.
4. Ensure the ash pan door is tightly closed during operation. An open ash pan door will allow excess draft through the firebox, causing overfiring. When emptying ashes, clean thoroughly behind the ash pan to allow complete closure.
5. Clean your chimney regularly to remove creosote buildup. A chimney fire is a fire hazard and will overfire your stove. See page 26, **“What to do if you have a chimney fire”**
6. During operation, if any parts of the stove or pipe begin to glow the stove is overfired. Do not add fuel. Close all doors, dampers and draft controls completely until glowing is eliminated and safe temperatures are restored. If overfiring conditions persist on subsequent burnings, contact your dealer for remedial action.



# Oval Cookstove Parts Diagram

See page 36 for part description

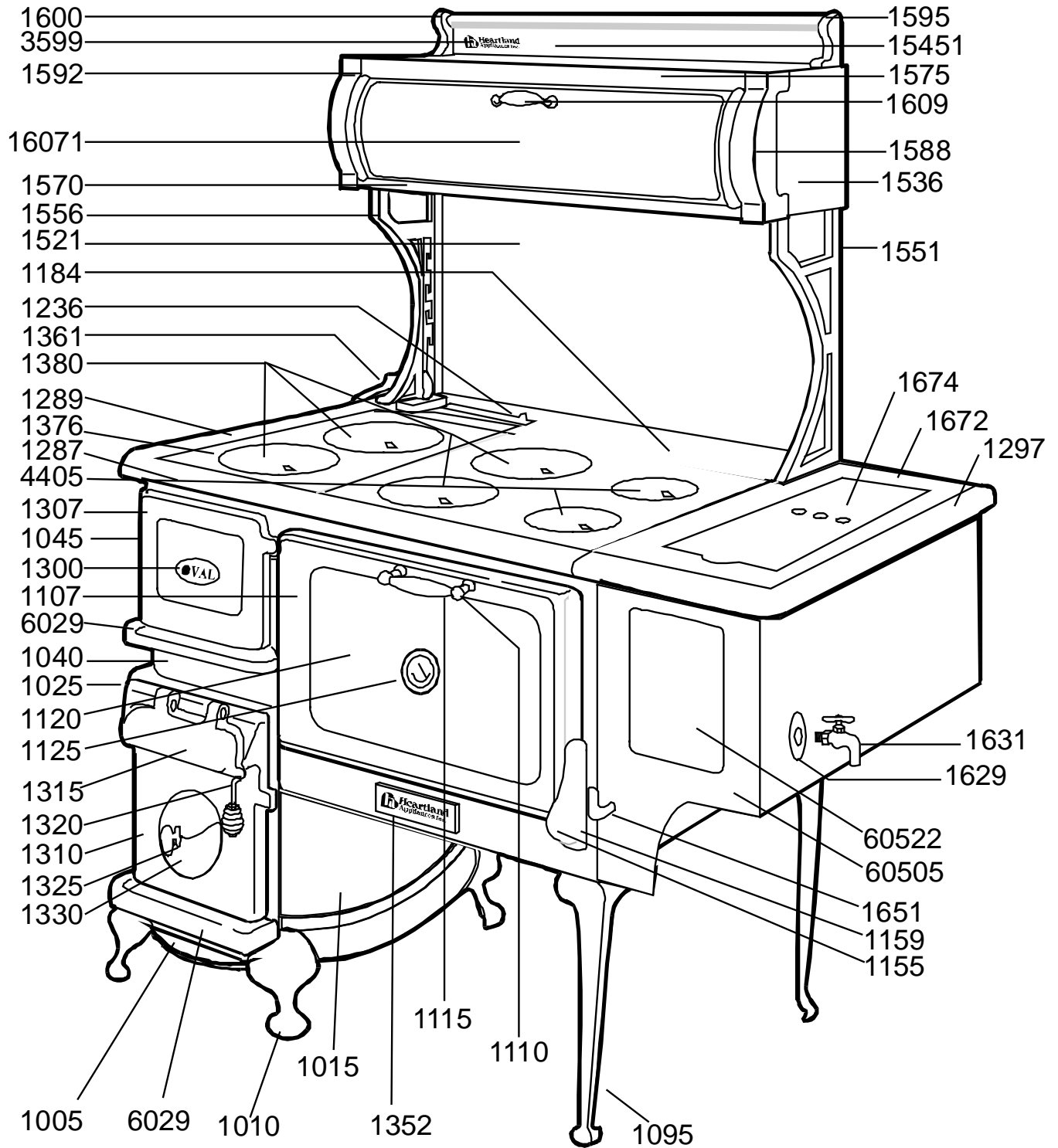

# SweetHeart Cookstove Parts Diagram

See page 36 for part description

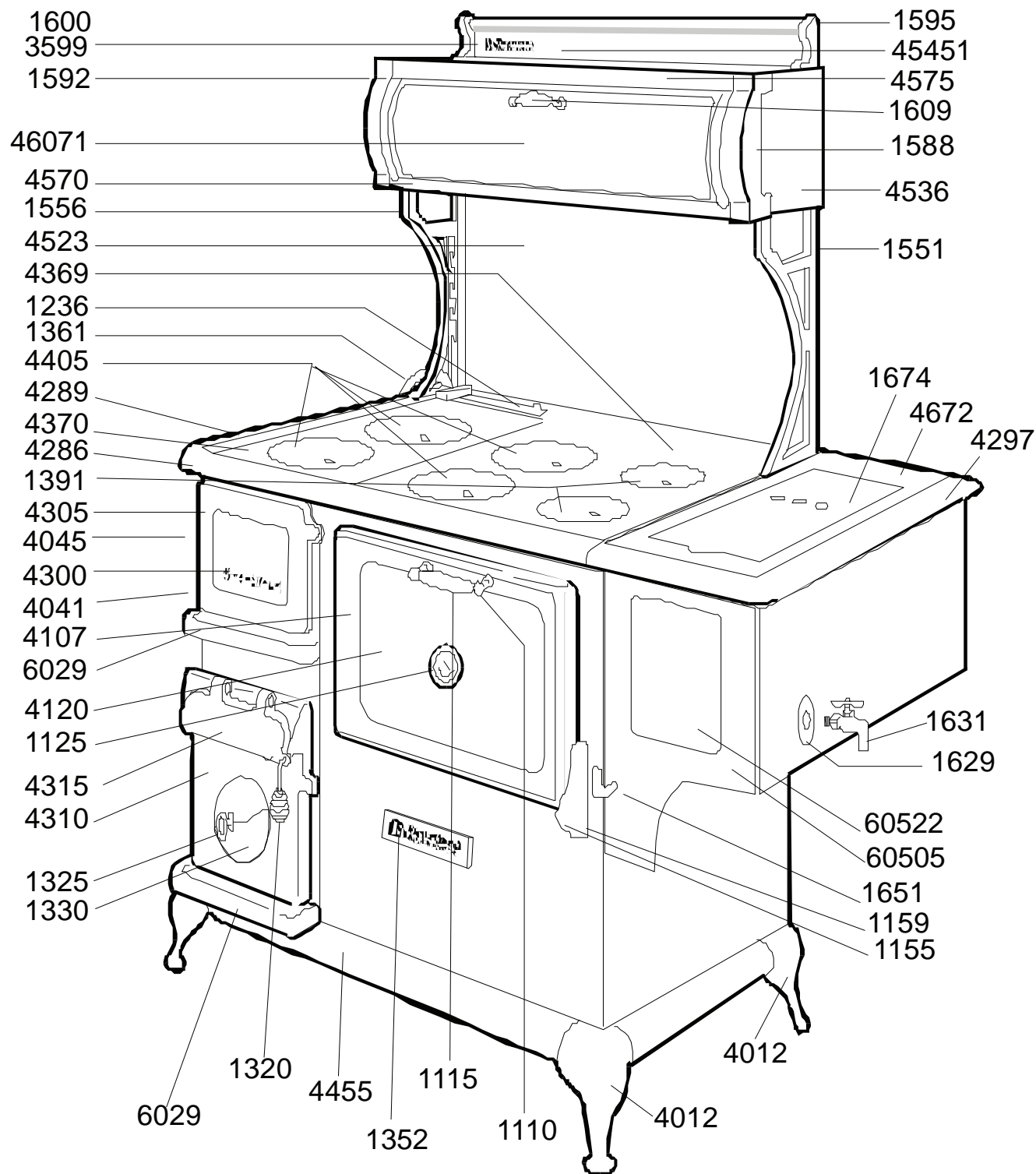

# Replacement Parts Diagram

See page 36 for part description

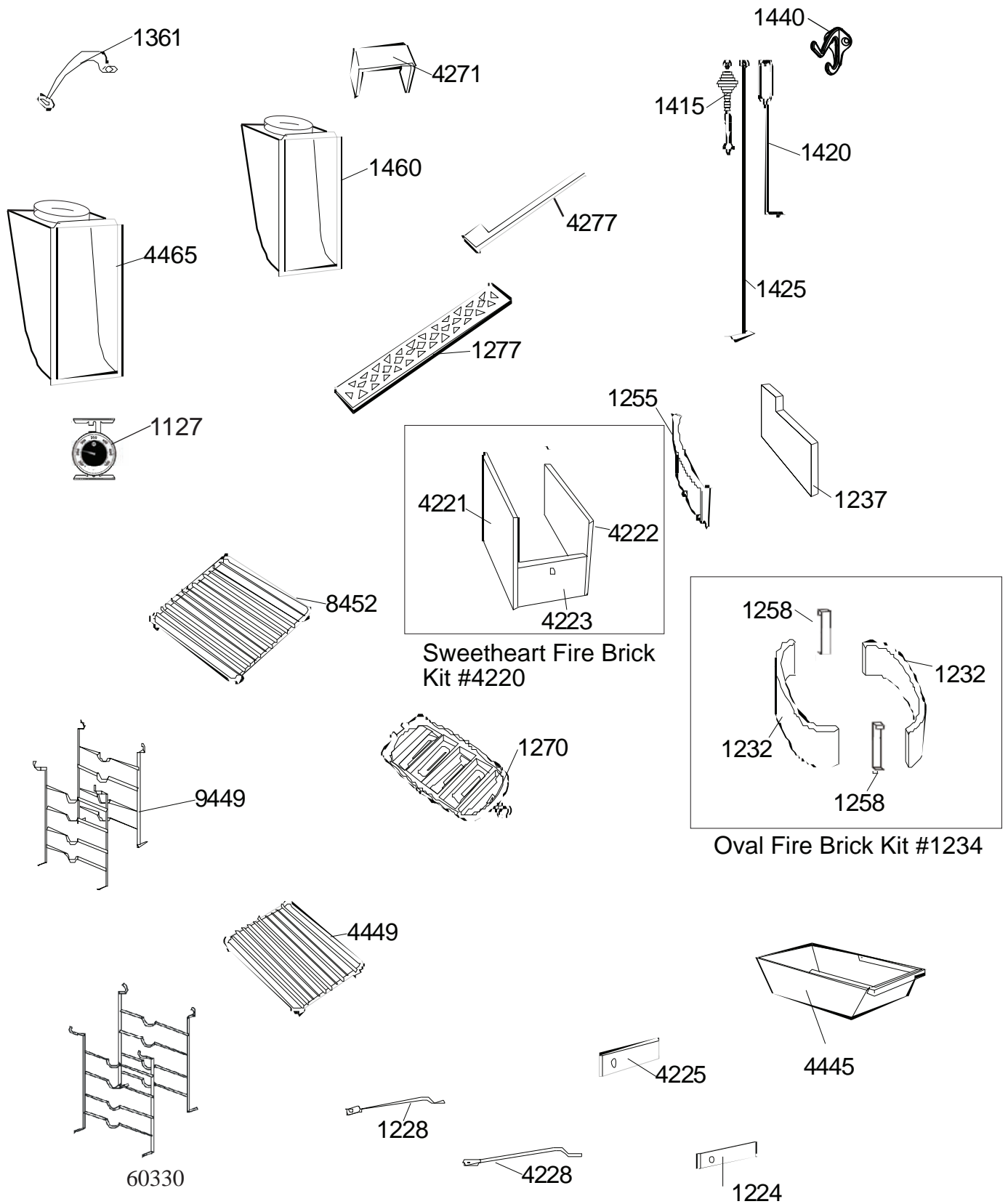

## Cookstove Parts List

Part #	Description	Part #	Description	Part #	Description
1005	Firebox base	1359	Screw & nut for lift handle	4222	Firebrick - right(SweetHeart)
1010	Short leg nickel plated	1361	Lift handle/washer complete	4223	Firebrick - front(SweetHeart)
1015	Firebox wrap around	1376	Key plate polished (Oval only)	4225	Damper slide(SweetHeart)
1045	Cast fire door	1380	9 ½" solid lid	4228	Damper arm(SweetHeart)
1095	Long stove leg	1391	6" lid	4271	Summer Grate support
1101	Complete oven door assembly	1415	Lid lifter	4277	Towel rack(SweetHeart #2)
1107	Oven door frame	1420	Stove poker	4286	Front surface band
1110	Oven door handle stanchion	1425	Ash scraper	4289	Wrap around band(SweetHeart #2)
1115	Woodenoven door handle	1440	Tool rack	4297	Reservoir band(SweetHeart #3)
1120	Outer oven door panel	1460	6" Dia Oval flue weldment	4300	Firedoor panel
1127	Interior Oven Thermometer	1521	Splash back	4305	Firedoor panel frame
1125	Oven door thermometer & clips	1536	Warming cabinet body	4310	Ash pan door
1155	Oven door spring	1545	Cresting panel	4311	Ash pan door-complete
1159	Right oven door hinge nickel	1551	Right cabinet bracket	4315	Ash pan door flap
1184	1 piece stove top (Oval)	1556	Left cabinet bracket	4369	SweetHeart one piece top
1224	Damper plate weldment (Oval)	1570	Lower cabinet front trim strip	4370	Key plate
1228	Sliding oven damper arm (Oval)	1575	Upper cabinet front trim strip	4405	7 3/4" solid lid
1232	Left or right Oval Split Brick (Oval)	1588	Right cabinet corner	4445	Ash pan
1234	Oval firebrick replacement kit	1592	Left cabinet corner	4449	Oven rack(SweetHeart)
1236	Slider knob	1595	Right cresting corner	4465	6" Dia SweetHeart flue weldment
1237	Upper Right Fire Brick-(Oval)	1600	Left cresting corner	4455	Front base rail
1258	Brick Holder (Oval)	1607	Cabinet door	4460	Base rail right or left
1255	Firebox cast lining - left (Oval)	1609	Cabinet door handle	4523	Splash back
1267	Wood grate frame	1629	Water Tap flange	4536	Warming cabinet body
1268	Wood grate slide	1631	Chrome water tap	4545	Cresting panel
1269	Wood grate pull	1651	Reservoir control lever	4570	Lower cabinet strip
1270	Wood grate complete	1672	Reservoir top frame	4575	Upper cabinet strip
1277	Towel rack (#2 Oval only)	1674	Reservoir lid	4607	Cabinet door
1287	Front surface band (#3 Oval only)	01750	White porcelain repair kit	4672	Reservoir top frame
1289	Wrap around band (#2 Oval only)	01751	Black porcelain repair kit	6029	Ash catch
1297	Reservoir curved band (#3 Oval only)	01752	Almond porcelain repair kit	60505	Reservoir front
1300	Firedoor panel	3599	Heartland nameplate w/clips	60522	Reservoir front insert panel
1307	Firedoor panel frame	4012	Adjustable Base leg	8452	Oven rack (Oval)
1310	Ash pan door	4041	Firebox front	9449	4 position rack support (Oval)
1311	Ash door, flap, spring handle	4045	Cast fire door	60330	4 position level rack
1315	Ash pan door flap	4107	Oven door frame		
1320	Handle-shaker door	4120	Outer oven door panel		
1325	Cast bell damper handle	4220	Firebrick - complete kit		
1330	Bell damper	4221	Firebrick - left(SweetHeart)		
1335	Bell damper tension spring				
1352	Ash clean out door ( dual key hole mount)				
1358	Key plate lift handle				



---

---

**If you have any questions or you need replacement parts, contact your dealer or call us direct at 800-223-3900. Our office hours are from 8:30 a.m. to 5:00 p.m. est**

Add on kits that are available for the Wood-burning cookstoves:

## **Water Jacket Kit**

**Can be used to supplement your existing hot water heater!**

**Oval Water Jacket Kit- #1506  
SweetHeart Water Jacket Kit- #4506**

## **Coal Burning Kit**

**Contains everything you need to convert your wood burner into a coal burner!**

**Oval Coal Kit- #1500  
SweetHeart Coal Kit- #4500**

## **Heat Shield Kit**

**Need more room? Cut your rear clearance requirements in half with this kit!**

**Oval Heat Shield Kit- #1241  
SweetHeart Heat Shield Kit- #4241**

## **Fresh Air Kit**

**If your home is tight and well insulated, then the fire in the stove may be “starved” for combustible air, then this kit is what you need!**

**Oval and Sweetheart Fresh Air Kit- #1017**

For pricing please call your dealer, or call AGA Marvel  
(800) 223-3900 or Fax (616) 754-9690

