



Sterling-Ht (Model 8532)

GAS-FIRED DIRECT VENT HEATER

Owner's Manual & Installation Guide

Operate and Maintain This Gas Heater
According To This Instruction Manual

Read This Manual in Its Entirety

WARNING: If the information in these instructions is not followed exactly, a fire, or explosion may result causing property damage, personal injury, or loss of life.

- Do not store, or use gasoline, or other flammable vapors and liquids near this or any other gas appliance!

WHAT TO DO IF YOU SMELL GAS:

- Do not try to light any appliance.
- Do not touch electrical switches; do not use the phone in your building.
- Immediately call your gas supplier from a neighbor's phone. Follow your gas supplier's instructions.
- If you cannot reach your gas supplier, call the fire department.

A qualified installer, service agency, or gas supplier must perform installation and service. In the Commonwealth of Massachusetts, all installation of gas lines and gas fitting shall only be done by a licensed gas fitter or licensed plumber.

AVERTISSEMENT: Assurez-vous de bien suivre les instructions donné dans cette notice pour réduire au minimum le risque d'incendie ou pour éviter tout dommage matériel, toute blessure ou la mort.

- Ne pas entresposer ni utiliser d'essence ni d'autre vaperurs ou liquides inflammables dans le voisinage de cet appareil ou de tout autre appareil!

QUE FAIRE SI VOUS SENTEZ UNE ODEUR DE GAZ:

- Ne pas tenter d'allumer d'appareil.
- Ne touchez à aucun interrupteur. Ne pas vous servir des téléphones se trouvant dans le bâtiment où vous vous trouvez.
- Appelez immédiatement votre fournisseur de gaz depuis un voisin. Suivez les instructions du fournisseur.
- Si vous ne pouvez rejoindre le fournisseur de gaz, appelez le service des incendies.

L'installation et service doit être exécuté par un qualifié installer, agence de service ou le fournisseur de gaz.



INFORMATION SHEET

Use this page to record all relevant information concerning the purchase, installation, and maintenance of your STERLING Ht Model 8532 Gas-Fired Direct Vent Heater. This information will facilitate servicing, purchase of replacement parts, and warranty claims (if necessary). Keep your original receipt in a safe place as proof of purchase.

Serial Number: _____

Fuel type (check one) _____ Natural Gas _____ Liquid Propane

Sold by: _____

Phone: _____ Date of Purchase: _____

Installed by: _____

Phone: _____ Date of Installation: _____

Gas Supplier: _____

Phone: _____

Read this Owner's Manual before installing, or operating the STERLING heater. Retain this manual for future reference.

SERVICE RECORD

Date	Who Performed Work	Work Performed	Notes:

WHAT	WHEN
Firebox cleaning.....	annually
Glass cleaning.....	as needed
Door Gasket.....	Replacement as needed

WELCOME

Congratulations on your purchase of Hearthstone’s Sterling Ht Gas-Fired Direct Vent heater. The Sterling incorporates the latest in balanced vent gas technology, which will provide you with clean, efficient heat for years to come. Combustion air comes directly from the outside of your home to the sealed firebox system, eliminating the potential for annoying back drafts or other problems associated with home depressurization. The combination of natural stones with cast iron gives the Sterling a pleasing look, which can be maintained with minimum care.

The Sterling will provide you with years of practical and convenient service. However, as with any gas appliance, the unit must be properly and safely installed and maintained by qualified service personnel to ensure safe and trouble-free operation.

READ THIS OWNER’S MANUAL

Operate and maintain this gas heater according to the instructions in this manual. Read this manual in its entirety.

THIS HEATER MUST BE INSTALLED AND MAINTAINED BY QUALIFIED SERVICE PERSONNEL

Verify the gas connections, and venting systems with requirements of local, regional, or national installation codes. Qualified service personnel must inspect the gas heater before use, and at least annually.

ALWAYS VENT TO THE OUTSIDE

Never vent the gas heater to other rooms, or buildings. Do not connect this gas appliance to a chimney flue serving a separate solid-fuel burning appliance.

MANUFACTURED BY:

Hearthstone Quality Home Heating Products, Inc.

317 Stafford Avenue

Morrisville, Vermont 05661-8695

USA

E-mail: inquiry@Hearthstonestoves.com

Web: www.Hearthstonestoves.com

TABLE OF CONTENTS

- WELCOME 2**
- OWNER’S INFORMATION..... 4**
 - LIGHTING INSTRUCTIONS4
 - DAILY OPERATIONS4
- INSTALLER’S INFORMATION 5**
 - UNPACKING AND INSPECTION5
 - STOVE DIMENSIONS & CLEARANCES TO COMBUSTIBLES6
 - VENTING INFORMATION.....9
 - ATTACHING YOUR VENTING.....15
- GAS CONNECTIONS 16**
 - LOG PLACEMENT17
 - INSTALLATION OF THE LOG SET.....17
 - REMOVAL OF THE LOG SET18
- LIGHTING THE UNIT THE FIRST TIME 19**
 - ODORS AND IMPURITIES.....19
 - PREPARE FOR LIGHTING.....19
 - INITIAL ADJUSTMENTS.....19
 - LIGHTING INSTRUCTIONS19
 - TURNING OFF THE UNIT.....20
- PILOT AND BURNER FLAMES 20**
 - VARIABLE OUTPUT CONTROL.....20
- GAS CONVERSIONS..... 21**
- ROUTINE MAINTENANCE AND CARE 22**
- PARTS LISTS 24**
 - TROUBLESHOOTING GUIDE26
 - LIMITED WARRANTIES29

SERVICE CAUTION

Any shield, door, or other component removed for servicing must be replaced prior to operating. Any components of the stove removed for servicing must be replaced prior to operating. If you believe your Sterling is not performing properly, immediately discontinue operation until the unit has been inspected and approved by qualified service personnel. Prior to servicing the unit, turn the valve control knob clockwise to "OFF". Ensure the unit is cool before servicing and cleaning. **Any safety screen, guard, or component removed during servicing must be replaced before operation. Do not use any components other than those approved by Hearthstone Quality Home Heating Products, Inc., otherwise all warranties are void. Do not substitute components!**

FIRE HAZARD

Do not store or use gasoline, or other flammable vapors or liquids near this appliance. The Sterling should be located out of traffic, and away from furniture, draperies, clothing, and other flammable materials.

SHOCK HAZARD (IF EQUIPPED WITH ACCESSORY FAN) The accessory blower is equipped with a three-prong (grounding) plug for protection against shock hazard and must be plugged directly into a properly grounded three-prong receptacle. Do not cut or remove the grounding prong from the plug.

HOT SURFACES

Certain exposed surfaces of the Sterling will reach high temperatures during normal operation. Clearances to combustibles must be maintained, as specified in the "Clearances To Combustibles" section of this manual. **Due to high temperatures, the appliance should be located out of traffic and away from furniture, draperies, clothing, and other flammable materials. Children and adults should be alerted to the hazards of high surface temperatures and must stay away to avoid burns to skin or possible clothing ignition. Ensure that young children are carefully supervised when in the same room as the appliance. Clothing or other flammable material must not be placed on or near the appliance.** (*Surveille les enfants. Garder les vêtements, les meubles, l'essence ou autres liquides à vapeur inflammables loin de l'appareil.*) Clean the area around, under, and behind the unit on a regular basis to prevent the accumulation of dust and lint.

 **WARNING: do not operate the appliance with the front glass removed, cracked, or broken. Replacement of glass should be done by a licensed or qualified service person. Only open front for routine service. Do not slam, or strike the glass.**

 **WARNING:** A qualified service technician should do installation, and repair. A qualified service technician must inspect the appliance before use, and at least annually. More frequent cleaning may be required due to excessive lint from carpeting, bedding material, pets, etc. It is imperative that the control compartments, burners, and circulating air passages of the appliance are kept clean and free of obstructions. (*S'assurer que le brûleur et le compartiment des commandes sont propres. Voir les instructions d'installation et d'utilisation qui accompagnent l'appareil.*)

OWNER'S INFORMATION

The installation must conform with local codes or, in the absence of local codes, the current National Fuel Gas Code, ANSI Z223.1 (NFPA 54), or CAN/CGA B149 Installation Code. (*Installer l'appareil selon les codes ou règlements locaux, ou, en l'absence de tels règlements, selon les Codes d'installation CAN/CGA-B149.*)



Warning: Do not use this appliance if any part has been under water. Immediately call a qualified service technician to inspect the heater, and to replace any part of the control system that has been under water. (*Ne pas se servir de cet appareil s'il a été plongé dans l'eau, complètement ou en partie. Appeler un technicien qualifié pour inspecter l'appareil et remplacer toute partie du système de contrôle et toute commande qui ont été plongés dans l'eau.*)

Certified for use by:
Board of State Examiners of Plumbers and Gasfitters
100 Cambridge Street, Room 1511
Boston, Massachusetts 02202

LIGHTING INSTRUCTIONS

The gas control knob is located on the top of the stove, in the rear, right-hand corner.

1. Set the on/off/T-stat switch or thermostat to the off position.
2. Unplug the blower accessory, if so equipped
3. Push in and turn gas control knob clockwise to "OFF". (*If not previously lit, the knob should be in this position.*)
4. Wait (5) five minutes to clear out any gas. If you then smell gas, STOP! *Smell all around the appliance area for gas. Be sure to smell next to the floor because some gases (LPG) are heavier than air and will settle on the floor. If you smell gas immediately follow the What To Do If You Smell Gas! warning on the cover of this Manual.* If you do not smell gas, go to the next step.
5. Turn gas control knob counterclockwise to "PILOT".
6. Push in control knob all the way and hold in. (You should hear the clicking of the igniter in the firebox) Verify ignition of the pilot. Continue to hold the control knob in for about 20 seconds after the pilot is lit. Release the knob and it will pop back out. Pilot should remain lit. If the pilot goes out, repeat the operation.

-  If knob does not pop out when released, stop and immediately call a qualified service technician or gas supplier.
 -  If the pilot will not stay lit after several tries, turn the gas control knob "OFF" and call a qualified service technician or gas supplier.
7. Turn gas control knob counterclockwise to "ON".
 8. Select "ON" or "T-STAT" position on the on/off/t-stat switch.
 9. Plug in the blower accessory, if so equipped.
 10. Set thermostat to "ON" and set the desired temperature setting.

Normally, if the "T-STAT" position was selected, the main burner is cycled on and off by the Thermostat or the "on", "off" switch located on the bottom of the Thermostat body.

TO TURN OFF THE GAS TO THE APPLIANCE

Turn the gas control knob clockwise to "OFF" position. If shutting the unit off for the non-heating season, this will improve the overall efficiency of the unit as the heat from the pilot is wasted in the summer. When putting the unit back into service follow the lighting instructions described on this page.

VARIABLE OUTPUT CONTROL

The gas control valve is equipped with a variable output control. This control varies the *rate* of heat produced by the unit by varying the gas pressure to the ember burner.

DAILY OPERATIONS

The homeowner can easily operate the Sterling gas-fired heater. The unit comes with a standard thermostat. Remote thermostats, or wall switches are available for purchase from your local Hearthstone dealer. Once the thermostat is installed and properly adjusted, the desired room temperature is maintained. By adjusting the variable output control located on the gas control valve, the rate of heat output can be varied to meet the heating requirements of the season. Choosing a low flame setting will result in longer burn cycles at a reduced output, while choosing a high flame setting will result in a shorter, hotter burn cycle. Through trial and error, the homeowner can select the optimum flame size for their setting and application. Also available is a variable speed blower. (Kit# 95-57320)

INSTALLER'S INFORMATION

Codes

Adhere to **ALL local codes** or, in their absence, the latest edition of THE NATIONAL FUEL GAS CODE ANSI Z223.1 (NFPA 54) or CAN/CGA B149 Installation Code, which can be obtained from:

**AMERICAN NATIONAL STANDARDS
INSTITUTE, INC.**

1430 BROADWAY
NEW YORK, NY 10018

OR

**NATIONAL FIRE PROTECTION
ASSOCIATION, INC.**

BATTERY MARCH PARK
QUINCY, MA 02269

The appliance, when installed, must be electrically connected and grounded in accordance with local codes or, in the absence of local codes, with the current NFPA 70-National Electrical Code or CSA C22.1-Canadian Electric Code.

A manufactured home (mobile) OEM installation must conform with the Manufactured Home Construction and Safety Standard, Title 24 CFR, Part 3280 (U.S.) or Standard for Manufactured Home Installation, ANSI/NCBCS A225.1 or Standard for Gas Equipped Recreational Vehicles and mobile Housing, CSA Z240.4.CAN/SCA Z240 MH (Canada). (*Installer l'appareil selon les codes ou règlements locaux, ou, en l'absence de tels règlements, selon les Codes d'installation CAN/CGA-B149.*)

FIBER LOG SAFETY INFORMATION

If the decorative fiber logs supplied with the Sterling are damaged, they must be replaced. The manufacturer, through your local Hearthstone dealer, supplies replacement parts. Do not replace fiber logs with any materials not approved by Hearthstone Quality Home Heating Products, Inc.

UNPACKING AND INSPECTION

Unpack and Inspect for Damage

The Sterling is packaged by the manufacturer to withstand normal shipment without damage. However, damage can still occur during transit, so take care to inspect for damage when unpacking and

installing the unit. If any damage, or a missing part, is detected, immediately contact your dealer. ***Do not install or put into service a damaged or incomplete heater.***

The unit should appear to be square and level. The sheet metal parts should be smooth and free of bends or dents. The enameled cast iron should be free of chips or cracks. If visible or concealed damage is found, contact your dealer.

The decorative fiber logs supplied with the Sterling are located in the firebox. Always use great care when handling the decorative fiber logs, as they are very fragile and subject to damage and breakage. To open the front, grasp both sides of the front cast facade, toward the bottom, and lift upward and then outward. The bottom will slide up and out. The whole piece is then easily removed. Set the front aside taking care not to chip or scratch the enamel. Next, locate the two rotating clips above the glass. Rotate the clips out of the "locked" position and tilt the top of the glass outward. Lift the entire glass up and out. The log set can now be inspected for damage. To take the unit off the pallet, remove the lag bolts, which fasten the unit to the pallet. Take care not to chip the enameled legs. Have someone help lift the stove off the pallet, and set it into place.

Packing List

- 1-Sterling Gas-fired Heater containing:
 - 3-Decorative Fiber Logs
 - 1- Bag Platinum Bright Embers
 - 1-AA Battery
 - 1-Owner's Manual and Warranty Card
 - 1-Thermostat and wire
 - 1-LP Conversion kit

- **WARNING! Do not operate the stove with the glass front removed, cracked, or broken.**

ITEMS REQUIRED FOR INSTALLATION

- * External regulator (for propane/L.P.G. only)
- * Piping which complies with all codes
- * Pipe sealant approved for use with propane/L.P.G. (resistant to sulfur compounds)
- * Manual shutoff valve
- * Sediment trap (page 16)
- * Tee joint
- * Pipe wrench
- * Phillips head screwdriver
- * Other parts as required by local code
- * Safety Glasses
- * Gloves
- * Stone Set

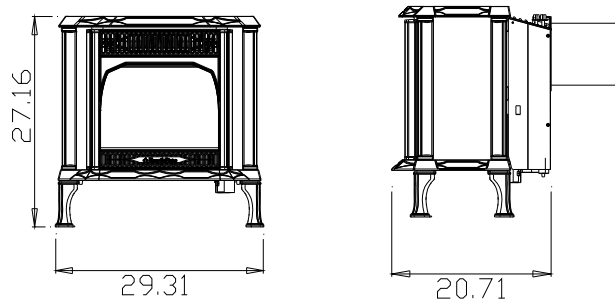

Sterling Dimensions

AIR SUPPLY

The Sterling Direct-vent does not require additional installer provided ventilation.

STOVE DIMENSIONS & CLEARANCES TO COMBUSTIBLES

Always maintain clearances around the stove, as shown in the Clearances to Combustibles figures. This allows for adequate ventilation.

If this appliance is to be installed on carpeting, vinyl tile or combustible material other than wood flooring, it must be installed on a metal or wood panel extending the full width and depth of the stove.

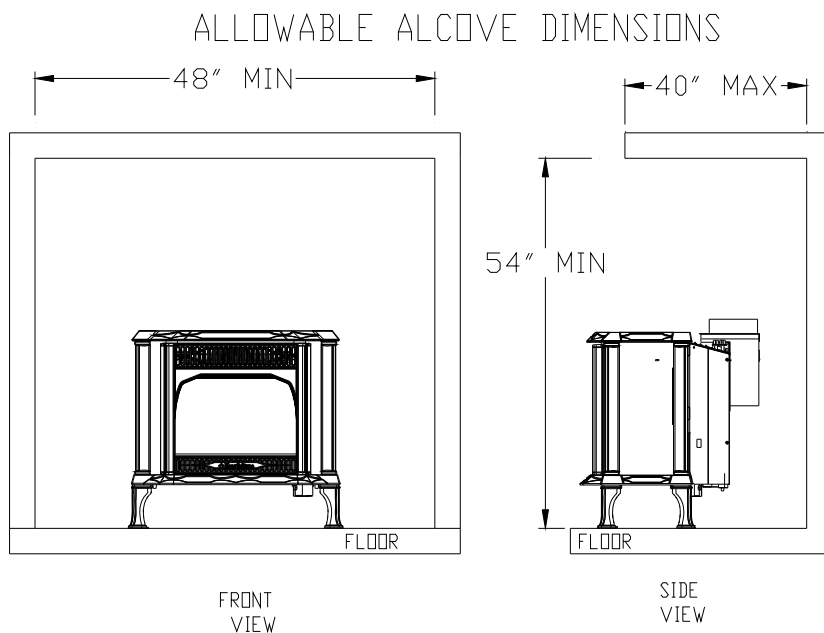

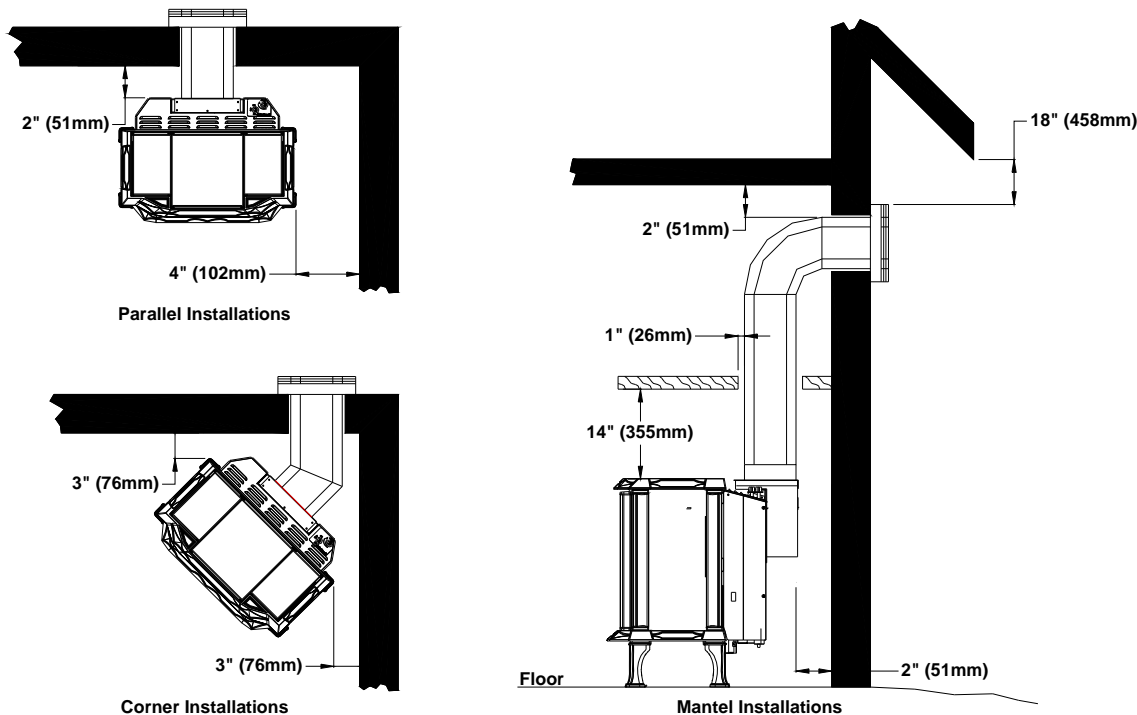

CLEARANCE TO COMBUSTIBLES

SPECIFICATIONS:

LISTED: DIRECT VENT GAS HEATER

Model: 8532-Sterling Ht DV

Testing Agency: Intertek Testing Services NA, Inc. (ITS)

Tested to: ANSI Z21.88-1998•CSA 2.33-M98 CAN/CGA 2.17

* You may keep your orifices the same if you wish to burn at the lower 33,000 btus with the top exit kit.

Venting Exit Type	Rear Exit – 5”x8” Pipe		*Top Exit – 4”x6” Pipe	
	NG	LP	NG	LP
Gas Type				
Input rating (Btu/hr) 0-2000ft	33,000	33,000	38,000	38,000
Maximum output (Btu/hr) 0-2000ft	26,600	27,400	30,200	31,300
Minimum input rating (Btu/hr)	13,600	11,900	13,900	11,600
Orifice size DMS 0-2000ft	43,52	55,63	38,51	53,63
Man. pressure- HI setting (in.w.c./kPa)	3.5/0.87	10.0/2.48	3.5/0.87	10.0/2.48
Man. pressure- LO setting (in.w.c./kPa)	1.2/0.3	3.3/0.8	1.2/0.3	3.3/0.8
Minimum inlet pressure (in.w.c./kPa.)	5.0/1.24	11.0/2.88	5.0/1.24	11.0/2.88
Maximum inlet pressure (in.w.c.)	7.0	13	7	13

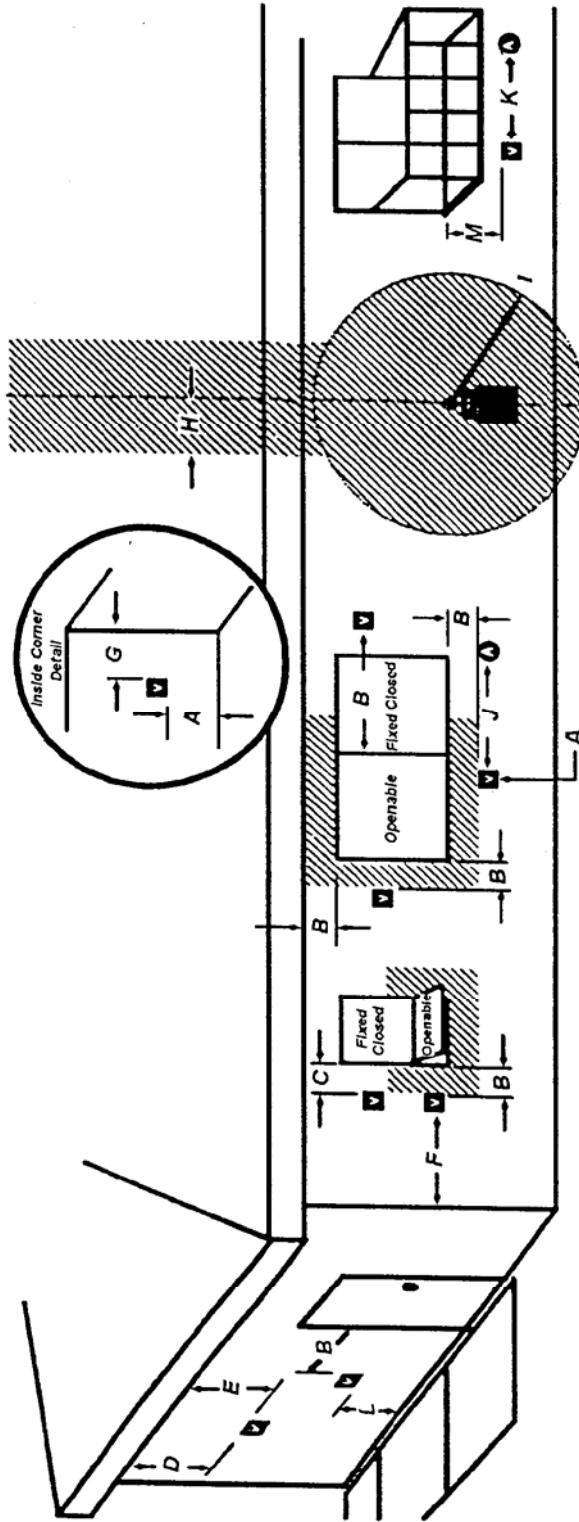

= vent terminal
 = air supply inlet
 = area where terminal is not permitted

- A= clearance above grade, veranda, porch, deck, or balcony [*12 inches (30 cm) minimum]
- B= clearance to window or door that may be opened
[*12 inches (30 cm) minimum for appliances ≤ 100 000 Btuh (30 kW)
36 Inches (90 cm) minimum for appliances > 100 000 Btuh (30 kW)]
- C= clearance to permanently closed window [minimum 12 inches (30 cm) recommended to prevent condensation on window] (g-USA)
- D= vertical clearance to ventilated soffit located above the terminal within a horizontal distance of 2 feet (60 cm) from the center-line of the terminal [18 inches (46 cm) minimum]
- E= clearance to unventilated soffit [12 inches (30 cm) minimum]
- F= clearance to outside corner - 12"
- G= clearance to inside corner - 12"
- H= *not to be installed above a meter/regulator assembly within 3 feet (90 cm) horizontally from the center-line of the regulator
- I= clearance to service regulator vent outlet [*6 feet (1.8 m) min (3 ft.-USA)]
- J= clearance to nonmechanical air supply inlet to building or the combustion air inlet to any other appliance (g-USA)
[*12 inches (30 cm) minimum for appliances ≤ 100 000 Btuh (30 kW)
36 inches (90 cm) minimum for appliances > 100 000 Btuh (30 kW)]
- K= clearance to a mechanical air supply inlet [*6 feet (1.8 m) min (3 ft.-USA)]
- L= † clearance above paved side-walk or a paved driveway located on public property [* 7 feet (2.1 m) minimum]
- M= clearance under veranda, porch, deck, or balcony [* 12 inches (30 cm) minimum †]

† a vent shall not terminate directly above a side-walk or paved driveway which is located between two single family dwellings and serves both dwellings*
 ‡ only permitted if verand, porch, deck, or balcony, is fully open on a minimum of 2 sides beneath the floor*
 * as specified in CGA B149 Installation Codes Note: local Codes or Regulations may require different clearances

VENTING INFORMATION

The Sterling is approved for installation only with the following venting manufacturers products.

- Simpson Dura-vent Direct Vent GS
- AmeriVent Direct
- Secure Vent systems
- Selkirk Direct-Temp™
- EXCELDirect

WARNING

This appliance must not be connected to a chimney flue serving a separate solid-fuel burning appliance.

The Sterling can be vented two ways:

- Straight out the back exit, using 5"x8" pipe.
- Top exit, using kit #95-60320. If you want to run your vent vertically, you must buy this vertical vent kit which will convert the venting pipe to 4"x6". The restrictor will be part of this kit. No restrictor is needed for a horizontal exit.

When referring to the rest of this section ensure which way your unit is being vented.

Note:

If the unit is vented vertically, 4"x6" pipe must be used.
If using Top Exit Kit, a 24" section of pipe must be used directly off of stove.

- Vertical Vent Cap
- Snorkel 36"
- Vinyl Siding Standoff 4 x 6 5/8"
- Round Ceiling Support Wall
- Thimble Covers
- Wall thimble

If the vent air intake system, for any reason, is disassembled, it must be reinstalled per the instructions provided for in the initial installation.

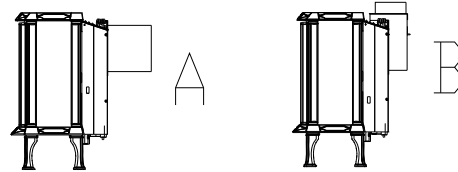

Allowable Venting Configuration Graphs

When determining the venting configuration, you must consider the position of the termination cap. There are 5 possible categories.

- Fireplace & Existing chimney installation
- Horizontal termination for 5"x8" pipe
- Horizontal termination for 4"x6" pipe
- Vertical termination straight or 2 45° elbows (4"x6" pipe only)
- Vertical termination, 1 or 2 90° elbows (4"x6" pipe only)

Every venting configuration must fall into one of these categories.

The vent/air intake termination clearances above the high side of an angled roof as follows:

APPROVED VENTING SYSTEM COMPONENTS

Component Description

- 90° Elbow
- 45° Elbow
- 6" Straight
- 9" Straight
- 12" Straight
- 24" Straight
- 36" Straight
- 48" Straight
- 11"-14 5/8" Adjustable Pipe Length
- Horizontal Vent Cap

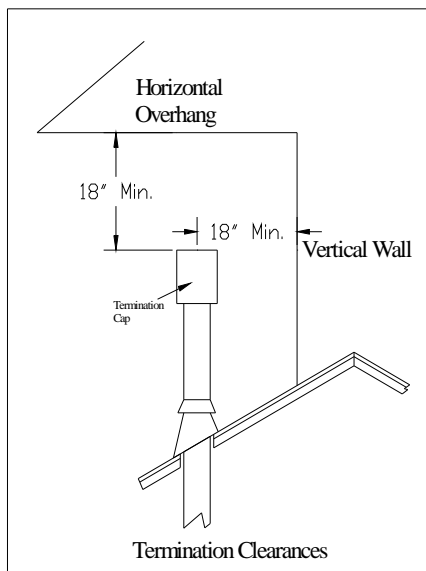

Roof Pitch	Feet	Meters
Flat to 6/12	1	0.3
7/12 to 9/12	2	0.6
10/12 to 12/12	4	1.2
13/12 to 16/12	6	1.8
17/12 to 21/12	8	2.4

The termination cap must not be recessed into a wall or ceiling.

A. Fireplace & Existing Chimney Installation

The use of an existing chimney as an air intake is not covered under the ANSI Z21.88-1998•CSA 2.33-M98 test methods and the resulting ITS/WHI product certification. The Code Authority Having Jurisdiction must be consulted prior to proceeding with this installation method.

STERLING VERTICAL VENTING USING:	
A CO-AXIAL ADAPTER A CO-LINEAR ADAPTER A CHIMNEY AS AIR INLET ADAPTER	
V (FT)	H (FT)
10' MIN. --- 35' MAX.	1.5' MAX. --- 1.5' MAX.
V + H = MAXIMUM ALLOWABLE VENT LENGTH	
FOR CORRECT DRAFT, HORIZONTAL VENTING MUST RISE 1/4" - 1/2" PER FOOT OF RUN.	

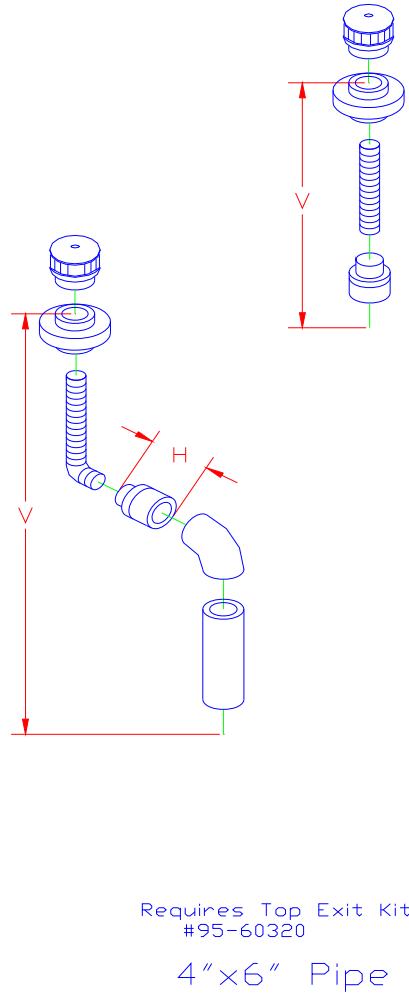
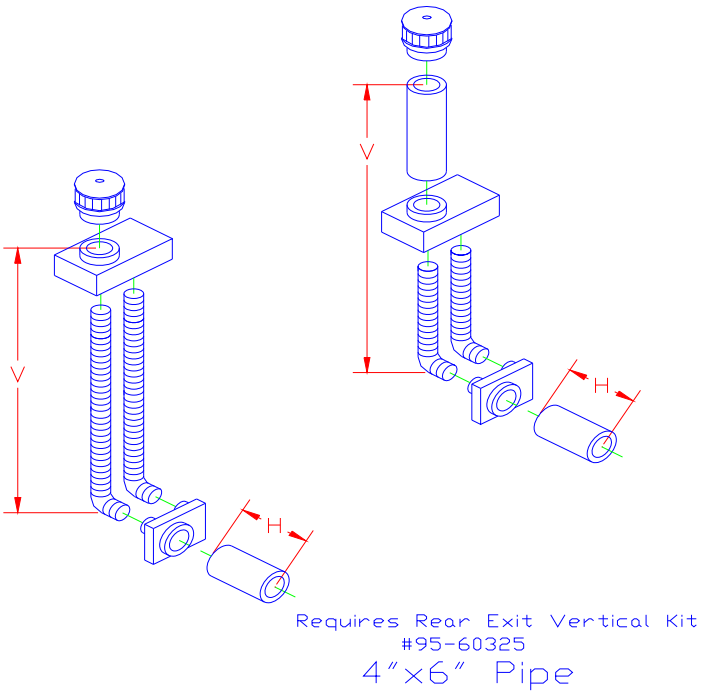

B. Horizontal Terminations for 5"x 8" Pipe.

STERLING HORIZONTAL VENTING USING: - 1 45° ELBOW - A SNORKEL - STRAIGHT PIPE	
5"x8" PIPE INSTALLATIONS ONLY	
<u>V (FT)</u>	<u>H (FT)</u>
0" MIN. ----- 7' MAX.	
$H1 + H2 = H (FT)$	
V + H = MAXIMUM ALLOWABLE VENT LENGTH	
FOR CORRECT DRAFT HORIZONTAL VENTING MUST RISE 1/4" - 1/2" PER FOOT OF RUN.	
DO NOT INCLUDE EXIT ADAPTER KIT AS AN ELBOW. NO RESTRICTOR PLATE REQUIRED.	

In the event that a termination cap is exposed to high winds, a 36" snorkel, or switching to 4" x 6-5/8" venting and it's requirements may be needed.

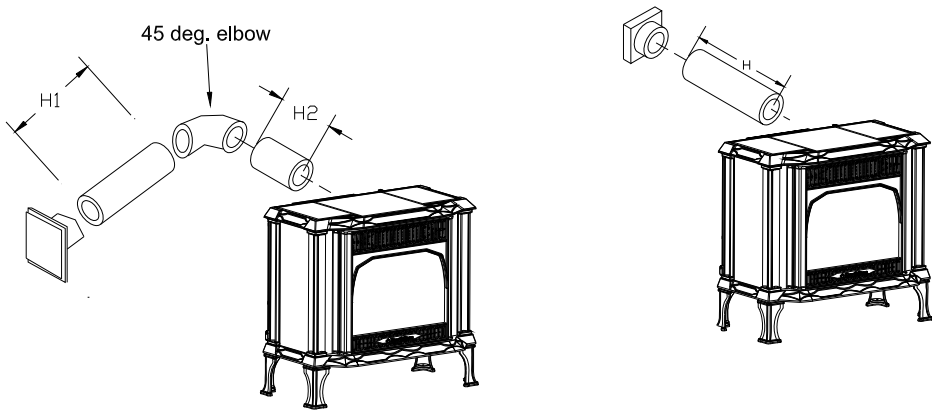

CENTERLINE OF PIPE IS 21.25" ABOVE THE FLOOR

C. Horizontal Terminations for 4"x 6" Pipe (Requires the use of Top Exit Kit, # 95-60320)

STERLING HORIZONTAL VENTING USING:

- (1) 45° ELBOW & ONE 90° ELBOW
- (1) 90° ELBOW
- (2) 90° ELBOWS
- SNORKEL ADAPTER

4"x6 5/8" PIPE INSTALLATIONS ONLY

V (FT)	H (FT)
2' MIN.	1'-2" MAX.
3'	3' MAX.
4'	5' MAX.
5'	6'-2" MAX.
6'	10' MAX.
7' - 9'	10' MAX.
10' MAX.	10' MAX.

H1 + H2 = H (FT)

V + H = MAXIMUM ALLOWABLE VENT LENGTH

FOR CORRECT DRAFT HORIZONTAL VENTING MUST RISE 1/4"-1/2" PER FOOT OF RUN.

DO NOT INCLUDE EXIT ADAPTER KIT AS AN ELBOW.

For Restrictor settings, refer to Vertical Termination restrictor chart.

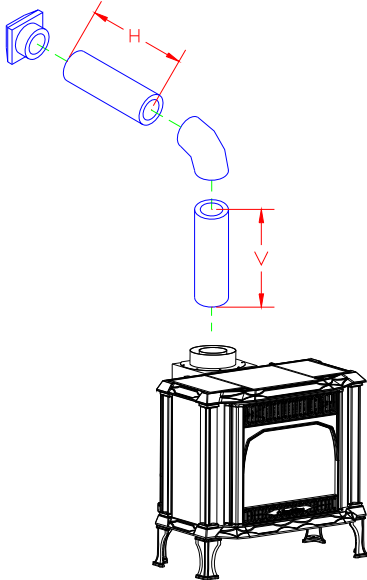
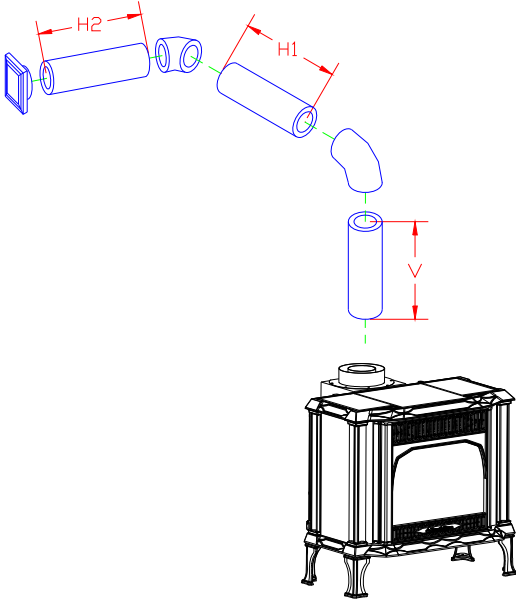
Note: All top exit configurations require a minimum of a 24" section of pipe directly off the unit.

D. Vertical Terminations - Straight or (2) 45° Elbows (4"x 6" Pipe Only)

STERLING: VERTICAL VENTING USING:	
- (2) 45° ELBOWS	
- STRAIGHT PIPE	
(4"x6 5/8" PIPE INSTALLATIONS ONLY)	
V (FT)	H (FT)
10' MIN. -----	6' MAX.
11' - 26' -----	6' MAX.
35' MAX. -----	6' MAX.
V MIN. = 10'	
V1 + V2 = V (FT)	
V + H = MAXIMUM ALLOWABLE VENT LENGTH.	
FOR CORRECT DRAFT, HORIZONTAL VENTING MUST RISE 1/4"-1/2" PER FOOT OF RUN.	

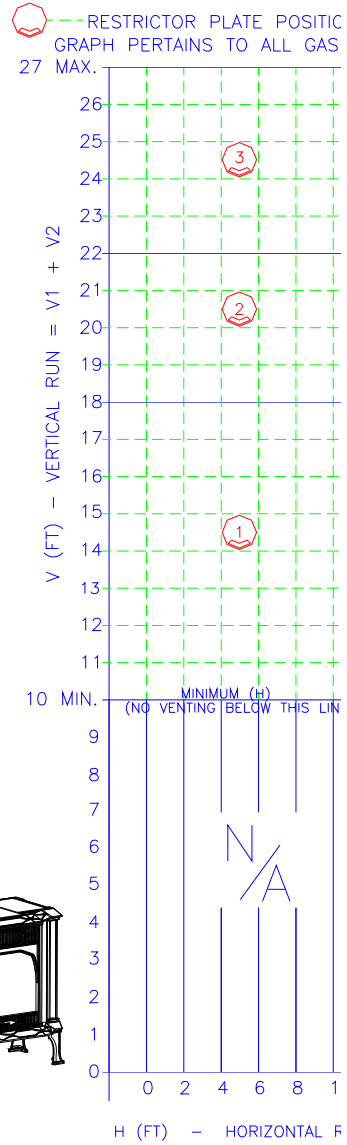
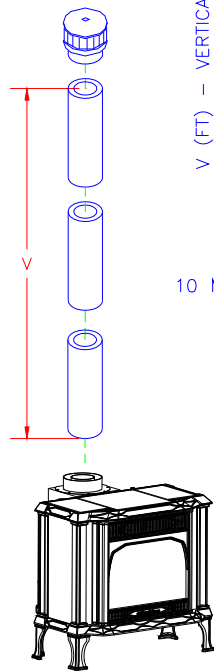
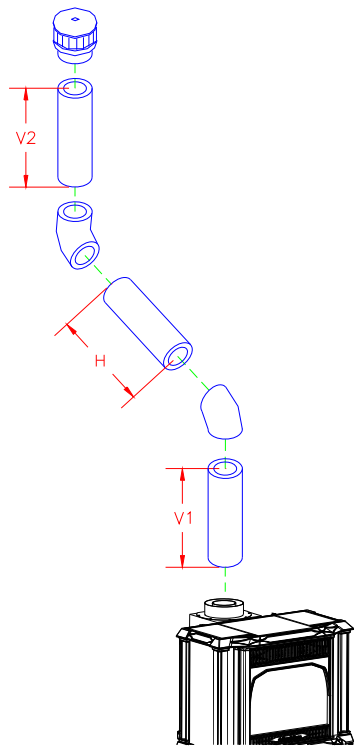

E. Vertical Terminations - (1) or (2) 90° Elbows (4"x 6" Pipe)

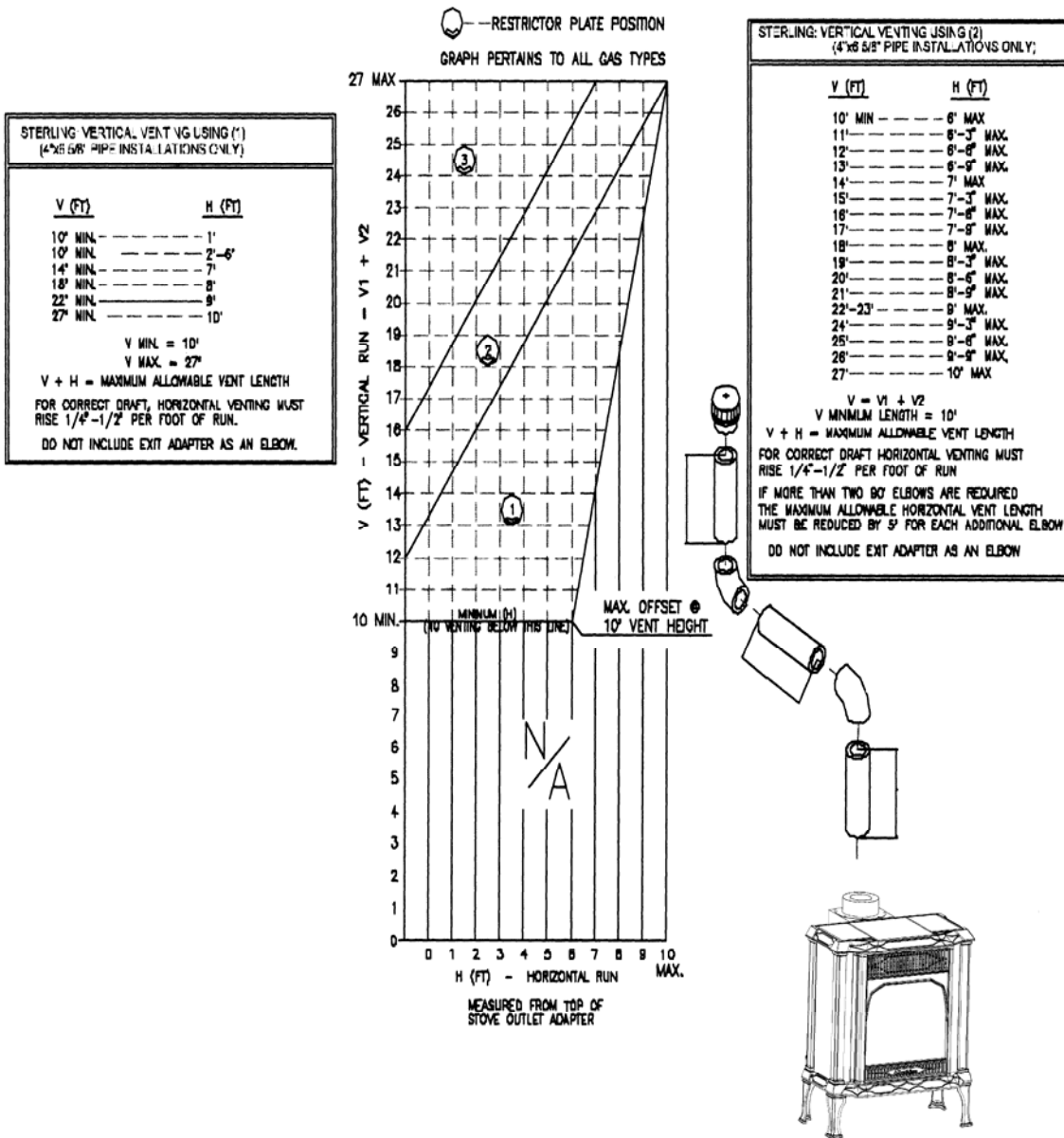

ATTACHING YOUR VENTING

Follow the instructions in either of the 5"x8" starter kits. If you are attaching the Top Exit kit, (#95-60320) for vertical venting configurations, the instructions will be provided with the kit.

INNER COLLAR:

Locate the 8 screw holes where the inner collar attaches to the heat exchanger. Attach the inner collar and gasket with the 8 screws provided with the collar.

OUTER COLLAR:

Locate the 8 screw holes where the outer collar attaches to the heat exchanger. Attach the outer collar and gasket with the 8 screws provided with the collar.

You are now ready to install your venting.

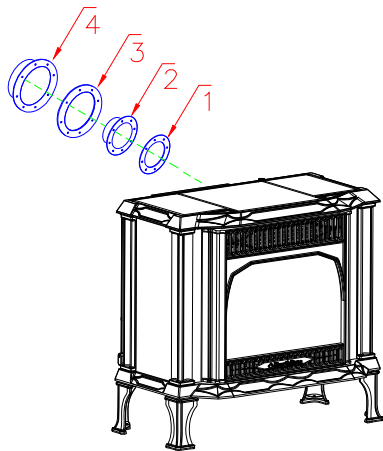

1. Gasket
2. Inner Starter
3. Gasket
4. Outer Starter

VENT RESTRICTOR

When converting the unit to a top exit, (4"x6" pipe), a restrictor is supplied with the kit. Instructions for installation of the restrictor are supplied with the kit. To adjust your restrictor for maximum flame appearance, first ensure the unit is cool before touching any part of the stove or venting. Refer to the Venting Configurations for recommended restrictor plate positions.

Loosen the Phillips head screw and rotate the locator, found on the rear middle of the stove to a position which corresponds to the appropriate chart setting. Shown below are the approximate locations of the settings 1-3; however it can be set in any position. Tighten the screw in the desired setting.

Note:

These positions are based on lab results and can have some variance.

IF the vent-air intake system is disassembled for any reason, reinstall per the instruction provided for the initial installation.

The flow of combustion and ventilation air must not be obstructed.

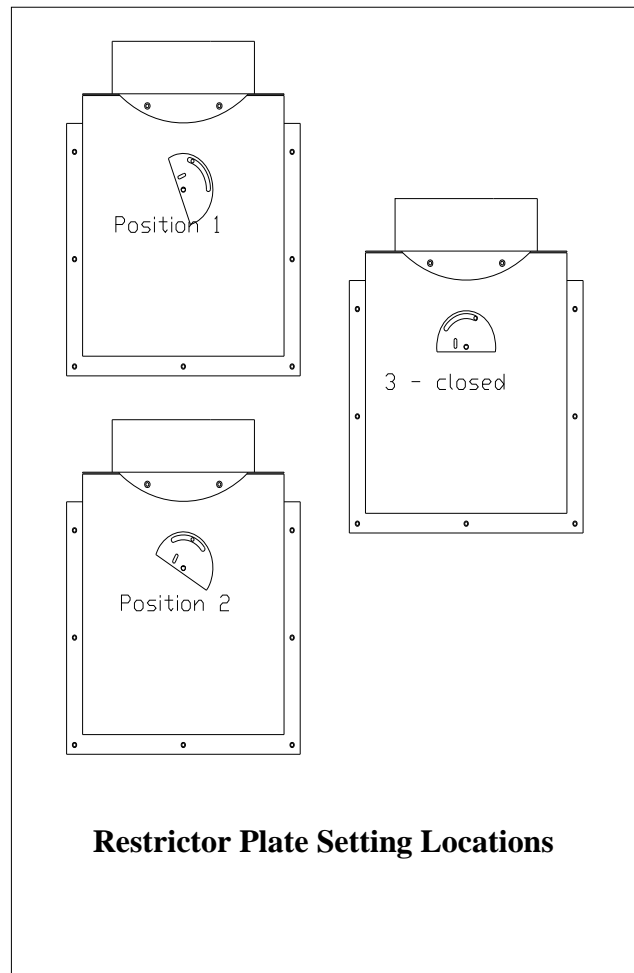

Cet appareil peut être installé dans un maison préfabriquée (mobile) déjà installée à demeure si les règlements locaux le permettent.

Cet appareil doit être utilisé uniquement avec les types de gas indiqués sur la plaque signalétique. Ne pas l'utiliser avec d'autres gas sauf si un kit de conversion certifié est installé

Conditionally approved for purchased mobile home installation. This appliance may be installed in an aftermarket permanently located, manufactured (mobile) home, except where prohibited by local codes.

This appliance is only for use with the type of gas indicated on the rating plate. This appliance is not convertible for use with other gases, unless a certified kit is used, available through your local Hearthstone dealer.

VALVE DESCRIPTION

- ① Gas cock knob
- ② Manual HI-LO adjustment or pressure regulator adjustment
- ③ Pilot adjustment
- ④ Thermocouple connection
- ⑤ Mounting for piezo & bracket
- ⑥ Inlet pressure test point
- ⑦ Outlet pressure test point
- ⑧ Main operator
- ⑨ Pilot outlet
- ⑩ Main gas outlet
- ⑪ Flange securing screw holes
- ⑫ Additional valve mounting hole
- ⑬ Alternative TC connection point
- ⑭ Thermoelectric unit

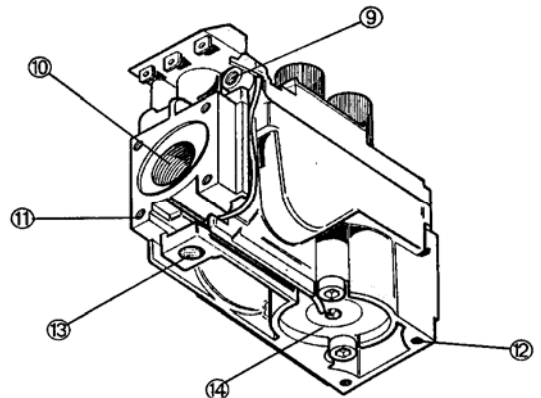
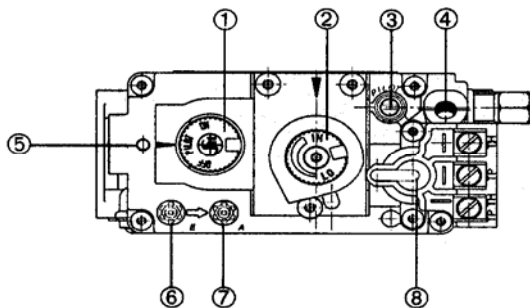

GAS CONNECTIONS

A top plate and a side cover must be removed to access the gas control valve. First remove the gas control valve knobs, by grasping the knobs firmly and gently pulling straight up on the knobs. Next remove the six screws holding the top plate on. Two are located on the sides, and four are located on top. To remove the side cover, loosen the two screws which have holes in the side for accessing. Do not remove these screws, just loosen them.. Slide the side cover upward and remove. The gas supply line connection is made to the Sterling's gas control valve, located on the back of the unit, in the lower right corner, using a 3/8" NPT fitting. The pipe must be sized to provide sufficient gas supply to meet the maximum demand of the unit. The supply line must include a manual shut-off valve and union so that the unit can be disconnected for servicing.

Use of a dedicated sediment trap is required by code, and by Hearthstone. Damage to components caused by the lack of a sediment trap is not covered by

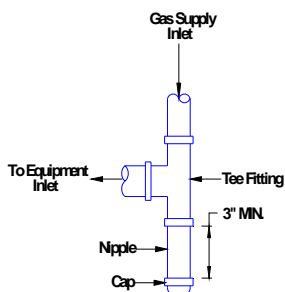

Sediment Trap is required

warranty.

Once connected to the gas supply, the gas inlet pressure, and manifold gas pressure, must be tested. The gas control valve has built in pressure taps for test gauge connections. The supply line pressure must be tested to ensure it meets the minimum pressure for the type of fuel in use (NG or LP).

Pressure Measurements: To measure the gas pressures, connect a manometer to the gas inlet tap (6) and manifold pressure tap (7) in the *Valve Description Figure*.

GAS PRESSURE ADJUSTMENT

A qualified technician must connect the heater to the gas supply, and leak test the unit before it is approved for use. Consult all applicable codes. The appliance, and its main gas valve, must be isolated from the gas supply piping system by closing its individual manual shutoff valve during any pressure testing of the gas supply piping system at test pressures equal to or greater than ½ psig (3.5kPa).

REPLACING THE GLASS

To replace the front glass, first shut the pilot light off. Next remove the front cast and glass assembly, as described in Installation of Log Set section. If the glass is broken, pull the broken fragments of glass away from the glass frame using heavy-duty gloves, as the pieces will be very sharp. Carefully replace the glass gasket as necessary, and replace the glass assembly and front cast.

- **WARNING! Do not use substitute materials. Use only parts that have been supplied by Hearthstone, through an authorized Hearthstone dealer.**
- **CAUTION! Do not clean the glass while the unit is hot. Allow approximately one hour before attempting cleaning.**

LOG PLACEMENT

Place only the decorative fiber log set supplied with the unit in the firebox. This log set is specifically designed to work with the provided ember burner. Do not use any other type of fiber logs, wood logs, or other materials in the firebox. If the original log set is damaged, or broken, contact your Hearthstone

dealer for replacement. The decorative fiber log set will last a long time; however, they will break easily if subjected to rough or improper handling.

Exact positioning of the log set is required in order to obtain a pleasing flame pattern and efficient combustion. Incorrect log placement can cause carbon build-up (soot); excess thermal stress on the log set and stove parts, reduced efficiency, and high levels of carbon monoxide. If the log set does not fit into the firebox exactly as outlined, contact your dealer for assistance.

INSTALLATION OF THE LOG SET

- 1) First remove the front cast and glass assembly. To remove the front, grasp both sides of the front cast facade, toward the bottom, and lift upward and then outward. The bottom will slide up and out. The whole piece is then easily removed. Set the front aside taking care not to chip or scratch the enamel. Next, locate the two rotating clips above the glass. Rotate the clips out of the “locked” position and tilt the top of the glass outward. Lift the entire glass assembly up and out.
- 2) Gently take the logs out of the firebox and remove the bubble wrap from the log set. Be careful not to damage the log set when unpacking. There are three logs, a Right, a Left and a “Twig”.
- 3) Gently place the Right Log (1) in the firebox, on the ember burner. The right log has a portion of twig on the top part of it. On the underside of the log there is an “L-shaped” cutout that lines up the log on the ember burner, in the appropriate position. It should sit as shown.

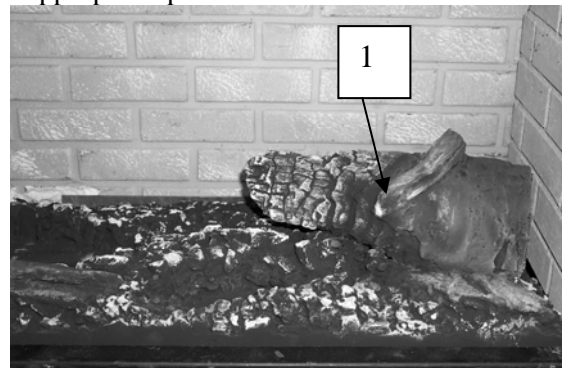

- 4) Gently place the Left Log (2) in the firebox, on the ember burner. On the underside of the log there is an “L-shaped” cutout that lines up the

log on the ember burner, in the appropriate position. It should sit as shown.

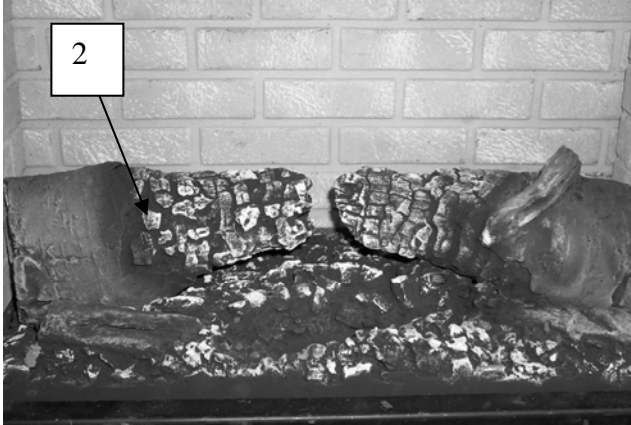

- 5) Gently place the Twig Log (3) in the firebox, on the ember burner and against the Right Log (1). The twig sits in a recessed part of the ember burner, which lines it up, in the appropriate position. It should sit as shown.

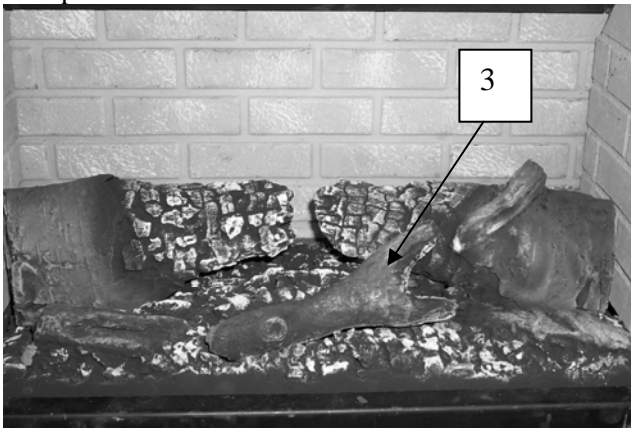

- 6) Open the bag of Platinum Bright Embers. Fluff up the pieces, and spread randomly over the logs and burners. These embers will glow brightly when the unit is running.
- 7) Re-install the glass assembly by lining up the three tabs on the bottom of the assembly with the three slots on the firebox. Slide the lower portion of the glass assembly into the slots and push it flush against the firebox. Rotate the clips into the "locked" position. Re-install the front cast by sliding the upper portion under the lip of the top and tilting the bottom in flush with the glass assembly. It should then slide downward and be snug in place. Make sure the glass assembly is properly secured to the firebox before turning the unit on. Be careful not to chip the enamel when installing the glass assembly or front cast.

REMOVAL OF THE LOG SET

🔥 Caution

Log set retains heat and can be very hot, if previously lit! Allow 1 hour after pilot light is turned off before handling.

To remove the log set, follow the Installation of Log Set instructions in reverse. Place the logs and in a safe area where they will not be damaged.

🔥 CAUTION

Fragile! Handle log set with care.

LIGHTING THE UNIT THE FIRST TIME

CAUTION: Lighting the Sterling-Ht for the first time and adjustments to the unit should be performed only by qualified service personnel.

SMOKE AND FUMES WARNING

When lit for the first time, the Sterling will emit some smoke and fumes. This is normal “off-gassing” of the paints and oils used in the manufacturing and assembly of the unit. Open windows to vent the room if necessary. The off gassing and fumes will subside after the first 10 to 20 minutes of operation.

ODORS AND IMPURITIES

A heater of this type may produce odors during heater operation due to impurities that may exist in the immediate area. Sources of impurities can be cleaning solvents, paint solvents, cigarettes, smoke, soot from scented candles, pet hair, dust, adhesives, new carpet, and/or textiles. Such odors will dissipate. However, opening a window or otherwise providing additional ventilation to the area can alleviate the condition. If any odor persists, contact your dealer or an authorized service technician.

PILOT LIGHT

The Sterling has a battery operated electric spark igniter, which ignites the pilot light by means of a spark at the pilot light assembly. To activate the igniter, turn the gas control knob to ‘Pilot’ and push and hold it down. You must install the included battery for the igniter. The battery compartment is located in the lower rear area of the stove. Do not attempt to light the unit with a match or by any means other than the electric spark.

PREPARE FOR LIGHTING

Prepare for the lighting procedure by adjusting the thermostat to its lowest setting or OFF position. If the gas control knob is not in the OFF position, turn the knob fully clockwise to OFF. Locate the variable output control knob and turn it fully counterclockwise to the highest setting.

INITIAL ADJUSTMENTS

Once the Sterling-Ht is set in place, connected and assembled as described in the Assembly of the Unit, Electrical Connections, and Gas Supply & Connections sections of this manual, the unit is ready

to be lit for the first time. Each unit is tested prior to shipment by the manufacturer, so ignition should take place without failure. However, a number of small adjustments may be necessary to compensate for variations in gas pressure, altitude, and other factors particular to each installation.

Prior to lighting the unit for the first time, wait 5 minutes to allow any residual gas within the unit to dissipate. Smell all around the appliance area for gas. Be sure to smell next to the floor because some gases (LP) are heavier than air and will settle on the floor. If you do not smell gas after this five-minute period, proceed with the lighting procedure. **If you do smell gas, do not proceed with the lighting procedure. Instead, immediately refer to the What to Do If You Smell Gas Warning, on the cover of this manual.**

LIGHTING INSTRUCTIONS

The gas control knobs are located at the top, right rear corner of the unit (*see diagram on next page*).

1. Set the on/off/T-stat switch or thermostat to the off position.
2. Unplug the blower accessory, if so equipped
3. Push in and turn gas control knob clockwise to “OFF”. (*If not previously lit, the knob should be in this position.*)
4. Wait (5) five minutes to clear out any gas. If you then smell gas, STOP! *Smell all around the appliance area for gas. Be sure to smell next to the floor because some gases (LPG) are heavier than air and will settle on the floor. If you smell gas immediately follow the What To Do If You Smell Gas! warning on the cover of this Manual.* If you do not smell gas, go to the next step.
5. Turn gas control knob counterclockwise to “PILOT”.
6. Push in control knob all the way and hold in. (You should hear the clicking of the igniter in the firebox) Verify ignition of the pilot. Continue to hold the control knob in for about 20 seconds after the pilot is lit (ensures thermocouple is up to temperature). Release the knob and it will pop back out. Pilot should remain lit. If the pilot goes out, repeat the operation.
 - If knob does not pop out when released, stop and immediately call a qualified service technician or gas supplier.
 - If the pilot will not stay lit after several tries, turn the gas control knob “OFF” and call a qualified service technician or gas supplier.

7. Turn gas control knob counterclockwise to "ON".
8. Select "ON" or "T-STAT" position on the on/off/t-stat switch.
9. Plug in the blower.
10. Set thermostat to "ON" and set the desired temperature setting.

2. If shutting the unit off for the non-heating season, turn the gas control knob fully clockwise to the "OFF" position. Do not force the knob to turn.

PILOT AND BURNER FLAMES

VARIABLE OUTPUT CONTROL

The gas control valve is equipped with a variable output control. This control varies the rate of heat produced by the unit by varying the gas pressure to the main burner tube. The length of the burn cycle is affected by a combination of heat output and the thermostat setting. If your stove turns on and off too often, try, first, reducing the burn cycle by turning the HI/LOW knob, on the control valve to a lower setting. Using the variable output control, the heat output of the unit can be reduced for mild fall and spring months, or maximized for the colder winter months. This adjustment can be made, by the homeowner, as necessary by turning the variable output control knob to "HI", "LO", or any setting in between.

Ht (High Turndown)

The Sterling is equipped with a dual valve system. This allows for the dramatic turndown that most other gas systems do not feature. Turn the secondary valve off, and the rear flames go out leaving the front flames on for a more relaxed ambience simmer. Turn the rear flames back on to enjoy the high flames for more heat. This *Ht* system is technologically designed to cover all aspects of heating pleasure.

AIR SHUTTER

The air shutter is preset by the manufacturer for optimum operation and should not need adjustment. However, it may need adjustment once the unit has been installed to compensate for variations in supply line pressure, altitude, and other variables. The air shutter is used to regulate the air-to-gas combustion mixture, which in turn adjusts the size and color of the flames.

AIR SHUTTER ADJUSTMENTS

The air shutter is adjustable while the stove is burning. The two air shutters on the ember burner are adjustable. The right one (while facing the front of the stove) is for the low burn portion of the ember burner and the left one (while facing the front of the stove) is for the high burn portion of the ember burner. The adjusters are located underneath the front of the unit, and operated by using a 3/8" wrench

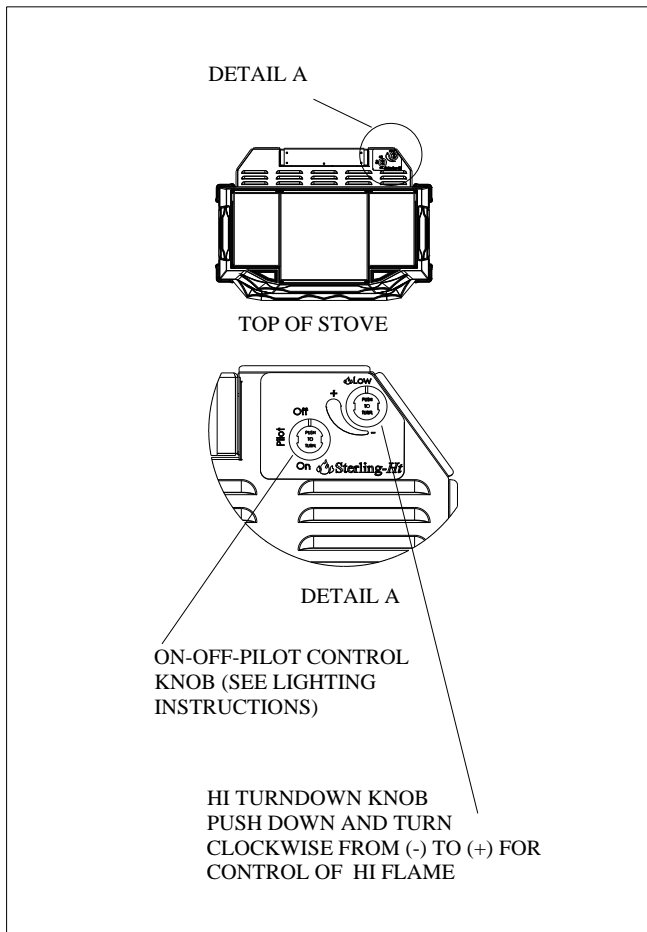

Once the pilot has been lit, and the gas control knob has been turned to the "ON" position, the main burners are lit by setting the "ON/OFF/THERMOSTAT" switch to "ON" or to "THERMOSTAT". If using the optional thermostat, turn the thermostat to "ON" and set it to a higher position so that it "calls" for heat (i.e. turns the unit on). The main burners should light immediately. Note that the thermostat controls the on/off cycling of the main burners, but the pilot remains lit regardless of the thermostat setting. To turn the pilot off, turn the gas control knob fully clockwise to the "Off" position.

TURNING OFF THE UNIT

1. Set the "ON/OFF/THERMOSTAT" switch to the "OFF" position, or turn the thermostat to the "OFF" position.

to loosen the bolt. Sliding the control levers forward or backward will open and close the shutters. This nut is hot and should not be touched. Use only metal tools for this adjustment. Sliding forward opens the air shutter, and sliding backward closes it. Tighten the nut after making adjustment. The air shutter is factory set and only a qualified gas technician should make adjustments. (refer to the image below to see a typical flame pattern)



PILOT ADJUSTMENT

The pilot light is preset by the manufacturer and should not need adjustment. The pilot light flame must be large enough to engulf the thermopile and thermocouple located next to the pilot, but not so large as to create excessive noise or consume excessive gas. (refer to the image below) However, it can be adjusted by means of the pilot light adjustment screw located on the gas control valve. Access the gas control valve as described in the Gas Connections section, on page 16. Note that the pilot flame must engulf the thermopile so that the thermopile can generate sufficient milli-voltage (325 to 500-mv) to power the millivolt gas control valve.

⚠️ WARNING! The control has an interlock device. If the stove has been lit, it will not relight immediately. After shutting off all gas flow, the pilot burner cannot be relit until the thermocouple has cooled, allowing the electromagnet to be released (Approx. 60 sec.). The gas control knob is designed to operate by hand. Do not use any tools during this operation.

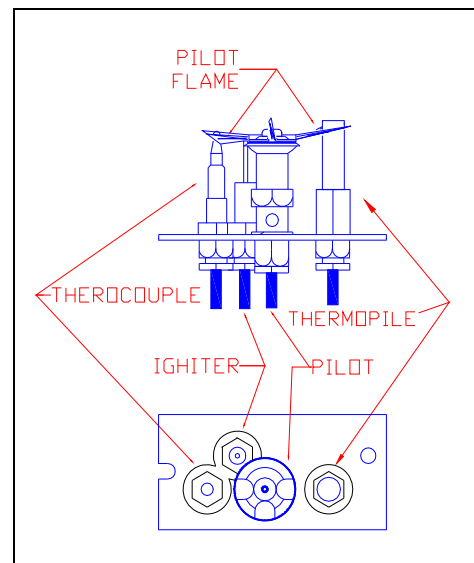

GAS CONVERSIONS

All Sterling stoves are set up for use with Natural Gas when built. However, these units are easily converted for use with LP, and visa versa. The instructions provided with the included conversion kit must be followed. **Only a Qualified Gas Technician should do the conversion.**

For checking, and properly adjusting, the manifold pressure, refer to the *Gas Connection section on page 16* of this manual.

🔥 Leak test before, and after, lighting the stove.

Fill out the label provided on back of the stove. The input rate of the heater is verified by checking the manifold pressure. If the manifold pressure is correct, then the input rate is also correct. Be sure to check the manifold pressure and properly adjust the pilot and main burner flames.

HIGH ALTITUDE CONVERSIONS

For high altitude installations, (610-1370 meters, 2000-4500 feet) the orifice sizes (DMS) for NG gas is 52 & 39 for 4"x6" pipe and 44 & 53 for 5"x8" pipe. For LP gas, the orifice sizes are 54 & 64 for 4"x6" pipe and 56 & 64 for 5"x8" pipe. See data plate for additional information. For high altitudes consult the local gas distributor, or the authority having jurisdiction for proper rating methods. If a conversion is necessary, the installer must fill out the conversion label provided with the kit and place it on the unit.

ROUTINE MAINTENANCE AND CARE

The Sterling requires minimal routine maintenance and care. The unit should always be cool and off when cleaned, or serviced.

Once a year the unit and venting system should be inspected by qualified service personnel to ensure that they are clean, prevent the accumulation of dust, lint and other debris, free of obstruction, safe and in good working condition. To clean the firebox, set the switch to the “OFF” position, and turn off the gas at the gas control valve.

When the unit is cool, remove the front cast and glass assembly and carefully remove the decorative fiber log set taking care not to damage the logs or chip the enameled cast iron. Clean the ember burner, and carefully vacuum the entire surface of the log set. Take care to thoroughly vacuum the ports (holes) on the top of the ember burner. With the decorative

fiber logs out of the firebox, re-install the glass assembly and briefly light the unit according to *lighting instructions* described on *Page 4*. Check to ensure a flame is burning from each burner port. Check the pilot. The pilot flame should be large enough to engulf the thermocouple and thermopile. Turn the unit off by setting the switch to “Off”, and turning off the gas control valve. Allow the unit to cool. Check and clean any burner ports that are not burning, or not burning properly. Clean the burner ports using a soft brush or vacuum cleaner. Adjust the pilot flame height if necessary. Complete the cleaning procedure by carefully placing the log set back in the firebox as described on in the installation of log set on page 17. Close and refasten the glass assembly and front cast. Turn on the gas, light the unit and check for proper operation and correct flame pattern.

- **WARNING! Do not use abrasives when cleaning the glass.**

Wiring Diagram - Sterling-Ht DV

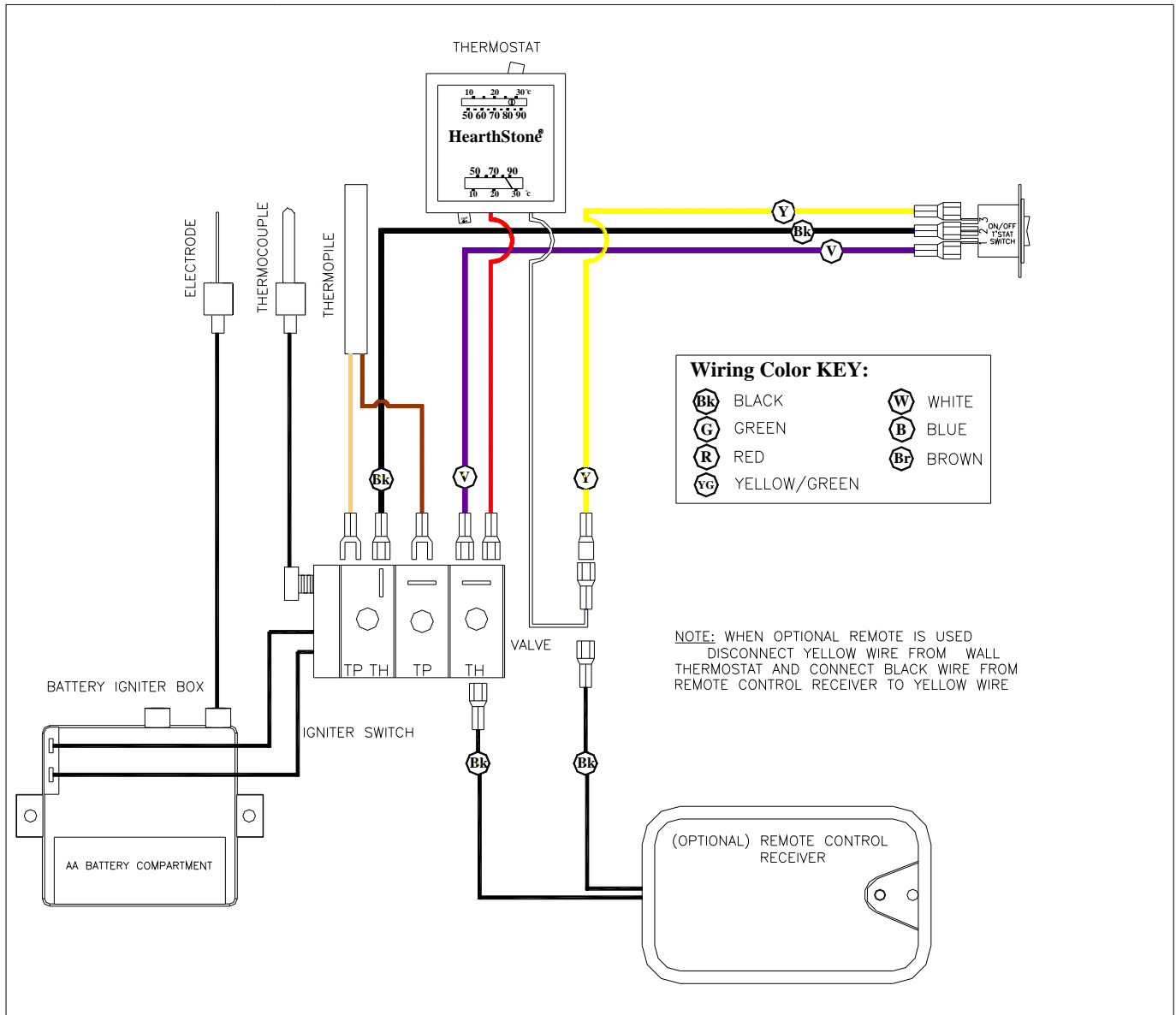

WIRING INSTRUCTIONS

Caution: Label all wires prior to disconnection when servicing controls. Wiring errors can cause improper and dangerous operation. Verify proper operation after servicing. *(Attention: Au moment de l'entretien des commandes, étiquetez tous les fils avant le débranchement. Des erreurs de câblage peuvent entraîner un fonctionnement inadéquat et dangereux.)*

PARTS LISTS

<u>Part No.</u>	<u>Description</u>	<u>Part No.</u>	<u>Description</u>
1541-330	STONE: TOP SIDE	5532-075	LOW FLAME KNOB, EXTENSION ROD
1541-340	STONE: TOP, CENTER	5532-077	HIGH FLAME KNOB, EXTENSION ROD
1546-462A	STONE: POL,8"x9-1/2", STG	5532-090	INLET COVER
1546-463	STONE: POL,3-1/2"x9-1/2",STG	5532-095	HEAT EXCHANGER HINGE PLATE
2510-310	FOOT: MATTE,STG		
2510-320	BOTTOM: MATTE,STG	5870-092	GLASS FRAME RETAINER CLIP
2510-330	COLUMN: STG	5953-230	AIR DEFLECTOR / HEAT SHIELD
2510-340	FRONT: STG		
2510-349	HEAT EXCHANGER BASE	7000-014	THERMOSTAT WIRE: 40' W/ TERMINALS
2510-350	HEAT EXCHANGER		
2510-360	TOP: STG		
3030-042	GLASS	7000-032	HARNES: WIRE,ON/OFF,STO/STG/TUC
3120-530	FIREBRICK PANEL: REAR	7211-406	ADAPTOR, SIT, CONTROL KNOB
3120-531	FIREBRICK PANEL: SIDE	7211-403	HIGH TURNDOWN CONTROL KNOB
3160-080	GASKET: TAPE,3/4"x1/16",AD	7200-243	ORIFICE: BURNER HOOD, NG, #43 (HIGH)
3160-530	GASKET: SET	7200-252	ORIFICE: BURNER HOOD, NG, #52 (LOW)
3160-531	GASKET: HEAT EXCHANGER	7200-120	ORIFICE: BURNER HOOD,LP,#55 (LOW)
3170-150	PLATINUM BRIGHT EMBERS		
3300-565	RATING LABEL: STG	7200-263	ORIFICE: BURNER HOOD,LP,#63 (HIGH)
4700-0620	FRONT TEFLON PADS	7210-104	BATTERY IGINTOR BOX (0373.801)
		7210-105	IGNITOR SWITCH: BATTERY OPER.
5532-010	STG DV FIREBOX	7211-054	GAS MANIFOLD
5532-014	PILOT SHIELD	7211-136	ORIFICE: PILOT,LP, .35mm,CONVERT TOP
5532-015	INLET PLENUM	7211-214	AIR SHUTTER
5532-017	ORIFICE MOUNTING PLATE	7211-215	FIBER EMBER BURNER
5532-020	EXHAUST HEAT EXCHANGER	7211-216	BURNER INLET TUBE
5532-025	REAR, TOP HEAT SHIELD	7211-316	GAS VALVE: HIGH TURNDOWN
5532-027	LEFT REAR SHIELD	7211-317	VALVE REGULATOR:,LP,SIT, CONV.
5532-029	RIGHT REAR SHIELD	7211-318	VALVE: UNREGULATED SIT MAIN BURNER
5532-040	SIDE STONE RETAINER	7211-370	BURNER:PILOT,CON TOP,3-WAY,NG,
5532-045	BRICK PANEL RETAINER	7210-090	THERMOPILE
5532-047	PANEL CLIP	7211-470	THERMOCOUPLE
5532-050	GLASS FRAME	7211-506	LOG: LEFT REAR
5532-060	STAINLESS STEEL BAFFLE	7211-507	LOG: RIGHT REAR
5532-070	VALVE BRACKET	7211-508	LOG: CENTER TWIG

ACCESSORIES AVAILABLE:

	KIT #
BLOWER KIT	95-57320
REMOTE CONTROL ON/OFF	90-56912
REMOTE CONTROL THERMOSTAT	90-56914
SPARK SCREEN	95-69320
FUEL CONVERSION: LP	95-56321
FUEL CONVERSION: NG	95-56320
TOP EXIT STARTER KIT	95-60320

- **WARNING! Do not substitute Materials.**

For replacement parts, or for information about parts or service, contact your authorized Hearthstone retailer. For the name of the authorized retailer nearest to you, visit our website at www.Hearthstonestoves.com, or e-mail us at inquiry@Hearthstonestoves.com.

RATING LABEL

MODEL # 8532-
 SERIAL #



MODEL NAME: STERLING-Ht DIRECT VENT GAS FIREPLACE HEATER
 LISTED: VENTED GAS FIREPLACE HEATER
 TESTED TO: ANSI Z21.88-2002 CSA 2.33-M02, CAN/CGA-2.17-M91

CERTIFIED FOR CANADA/HOMOLOGUE POUR LE CANADA
 ALSO FOR MOBILE HOME INSTALLATION

CAUTION: DO NOT OPERATE WITH GLASS REMOVED, CRACKED, OR BROKEN.

Replacement on the panel should be done by a licensed or qualified service person.
 CAUTIONNER: N'opère l'appareil avec le verre enlevé, craqué ou cassé. Le remplacement du panneau devrait être fait par une personne de service qualifié ou autorisée.

This appliance must be installed in accordance with the local codes, if any, if not, follow the National Fuel Gas Code, ANSI Z223.1 or Canadian Installation Codes, CAN/CGA B149. (Installer l'appareil selon les codes ou règlements locaux, ou, en l'absence de tels règlements, selon les Codes d'installation CAN/CGA-B149.)

	FUEL TYPE:		FUEL TYPE:	
	■ NG 5" x 8" VENTING	■ LP	■ NG 4" x 6" VENTING	■ LP
INPUT RATING (Btu/hr) 0-2000 ft	33,000	33,000	38,000	38,000
INPUT RATING (Btu/hr) 2000-4500 ft	31,500	31,900	36,900	37,600
ORIFICE SIZE (DMS) 0-2000 ft	43, 52	55, 63	38, 51	53, 63
ORIFICE SIZE (DMS) 2000-4500 ft	44, 53	56, 64	39, 52	54, 64
MANIFOLD PRESSURE - LO (in. W.c./kpa)	1.2/0.3	3.3/0.8	1.2/0.3	3.3/0.8
MANIFOLD PRESSURE - HI (in. W.c./kpa)	3.5/0.87	10.0/2.48	3.5/0.87	10.0/2.48
MINIMUM INLET PRESSURE (in.w.c./kpa)	5.0/1.24	11.0/2.88	5.0/1.24	11.0/2.88
MINIMUM INPUT RATING (btu/hr) 0/2000 ft	13,600	11,900	13,900	11,600
MAXIMUM OUTPUT (btu/hr) 0-2000 ft	26,600	27,400	30,200	31,300

WARNING: Improper installation, adjustment, alteration, service or maintenance can cause injury or property damage. Refer to the owner's information manual provided with this appliance. For assistance or additional information consult a qualified installer, service agency or the gas supplier. (L'AVERTISSEMENT: L'installation inconvenante, ajustement, modification, service ou entretien peut causer le dommage de propriété ou blessure. Référez au manuel d'information de propriétaire fourni cet appareil. Pour l'assistance ou information supplémentaire consultez un qualifiée installateur, agence de service ou le fournisseur de gaz.)

MINIMUM CLEARANCES TO COMBUSTIBLES

EDGE OF TOP TO: CEILING / MANTLE (17") 14" / 356mm
 BACK OF STOVE TO: BACKWALL 2" / 50 mm
 EDGE OF SIDE TO: SIDEWALL 4" / 100 mm

ELECTRICAL RATING:
 115 VOLTS @ 60Hz, LESS THAN 2.0A

Several Optional kits are available through HearthStone or your local HearthStone dealer. A blower assembly may be used (kit# 95-57320), spark screen (kit# 95-69320), top exit (kit# 95-60320), and two different remote controls (kit #90-56912 & kit #90-56914) are optional as well.

This appliance is only for use with the type of gas indicated on this rating plate and may be installed in an aftermarket, permanently located, manufactured (mobile) home where not prohibited by local codes. See owner's manual for details. This appliance is not convertible for use with other gases, unless a certified kit is used. If the vent air intake system is disassembled for any reason, reinstall per the instructions provided with the initial instructions. This vented gas fireplace heater is not for use with air filters. This appliance must be properly connected to a venting system in accordance with the manufacturer's installation instructions.

VENTED GAS FIREPLACE HEATER - NOT FOR USE WITH SOLID FUEL.



MANUFACTURED BY: HearthStone, MORRISVILLE, VERMONT 05661

Date of Manufacture

2004 2005 2006 Jan Feb Mar Apr May Jun Jul Aug Sep Oct Nov Dec

DO NOT REMOVE OR COVER THIS LABEL

MADE IN USA

3300-565

TROUBLESHOOTING GUIDE

Symptom	Possible Cause	Corrective Action
1. Pilot will not light.	A. Insufficient gas pressure, air in the pilot line, or dirty or kinked gas line.	A. Using the piezo sparker, try to light the pilot. If it will not light, check the inlet gas pressure.
	B. Pilot orifice plugged.	B. Clean or replace the pilot assembly.
	C. Defective or misaligned electrode at pilot.	C. If a match lights a pilot, check the electrode gap and location. Should be a 1/8" gap in the flame area.
	D. Defective igniter.	D. Check for a good connection between igniter and electrode. Check wire insulation. If properly connected and no spark, check/replace battery. With new battery and still no spark replace igniter.
	E. After sitting for "off" season (summer), pilot assembly may be dirty.	E. Clean or replace the pilot assembly.
2. Pilot will not stay lit after carefully following lighting instructions.	A. Low or too high gas pressure	A. Check for proper inlet pressure for the gas being used.
	B. Faulty connections.	B. Measure voltage between valve body and solder connection on the rear of the valve (where the blue wire connects). It should be no less than 7 mV.
	C. Defective thermocouple.	C1. Ensure that the thermocouple connection at the gas valve is tight. C2. Check thermocouple output using milli-volt meter. Disconnect from valve and read voltage across wire ends. If the reading is less than 15 mV, replace the pilot assembly. C3. If burning NG, check pilot flame to see that it is impinging on the top of the thermocouple. Clean or replace pilot for maximum flame impingement.
	D. Pilot dirty or plugged.	D. Clean or replace the pilot assembly.

Symptom	Possible Cause	Corrective Action
3. Pilot burning, no gas to main burner, valve knob in the "ON" position, thermostat and/or on/off/t'stat switch in the "ON" position.	A. Thermostat switch or wires defective.	A. Check thermostat/wiring for proper connections. Place jumper wire across terminals at thermostat. If burner comes on, replace defective thermostat. If not OK, place jumper across thermostat wires at gas valve. If burner comes on, tighten connections, or replace faulty wires.
	B. Thermopile may not be generating sufficient voltage.	B. Check thermopile output, using a milli-volt meter. If the optional on/off kit has not been installed, take the readings across generator terminals of the gas valve. TPTH and TP). With the on/off kit, take the readings across TH and Terminal block (which corresponds to #3 on the switch). Milli-volt reading should be greater than 325 mV. If not, replace the pilot assembly. If the meter reading is OK, but the burner does not come on, replace the gas valve.
	C. Plugged burner orifice.	C. Remove and check burner orifice, clean or replace. Note: do not use any metal cleaning device, as this may damage the orifice.
4. Pilot and burner come on, but go out after some warm-up.	A. Inconsistent, of insufficient flame on thermopile.	A. Adjust pilot flame size and assure that the flame is aimed directly at the thermopile.
	B. Insufficient gas pressure.	B. Check line pressure to ensure that the correct inlet pressure is present for the type of gas being used. If propane pressure is inconsistent, check for water condensation at the regulator.
5. Frequent pilot outage problem.	A. Pilot flame may be too low or blowing, (high), causing the pilot safety to drop out.	A. Clean and/or adjust the pilot flame for maximum impingement on the thermopile and thermocouple.
6. Glass fogs	A. A normal result of gas combustion.	A. After the heater has warmed up, the glass should clear.
7. Blue Flames	A. A normal result during the first 20 minutes.	A. Flames should begin to turn more yellowish after 20 minutes of burning. B. If the blue color stays; adjust the air shutter for a proper burn.

Symptom	Possible Cause	Corrective Action
<p>8. Floating flames, lazy ill-defined, quiet flames, which roll around, sometimes completely off of the port, sometimes with overly, yellow tips. Possible sooting. Usually accompanied by the odor of aldehydes.</p>	<p>A. Potentially dangerous incomplete combustion due to incorrect air to fuel ratio (lack of combustion air or excessive fuel delivery I.e. excessive gas pressure, overrating of appliance). B. Incorrect air intake/exhaust flow system. Causes may be: B1. Blocked burner. B2. Blocked primary air B3. Blocked secondary air inlets</p>	<p>A. Check the appliance input rate and reduce if necessary. The air intake/exhaust flow system may be too restrictive or blocked (the rate at which the exhaust leaves [draft] determines the rate at which the combustion air is delivered). Poor draft results in insufficient air delivery or a restricted exhaust. Correct air intake/exhaust flow system. B1. Clear ports. B2. Clear obstructions. B3. Clear obstructions. C. If gas pressures are correct and the flames stay the same, adjust the air shutter for a proper burn.</p>
<p>9. Burner flashback. Air-gas mixture ignites inside the burner near the orifice, usually creating a roaring noise like a blowtorch. The problem is an imbalance of gas flow velocity and burning speed pattern.</p>	<p>A. Excessive. B. Burner input underrated. C. Valve leak if flashback occurs with burner valve in off position. D. Improper gas pipe size.</p>	<p>A. Adjust the air shutter for a proper burn. B. Check input rate. Check input pressure using a manometer. Confirm correct gas pressure at house meter or tank (call gas company). Confirm burner orifice size. C. Replace valve. If above corrections do not eliminate flashback, replace burner. D. Correct plumbing.</p>
<p>10. Delayed ignition (makes a sudden "whoosh" noise as the burner lights). This is a buildup of gas prior to ignition. This is more prevalent with propane (LP) fuel.</p>	<p>A. Incorrect air-to-fuel ratio. A1. Primary air incorrect. A2. Burner ports plugged. B. Improper log placement.</p>	<p>A1. Adjust the air shutter for a proper burn. A2. Open ports to allow for proper travel of flames. B. Reposition logs to eliminate interference with flame travel.</p>

HEARTHSTONE GAS-FIRED STOVE AND INSERT LIMITED WARRANTIES

These warranties give you specific legal rights. You may also have other rights that vary from State to State.

Hearthstone Quality Home Heating Products, Inc. (Hearthstone) warrants **to the original purchaser only** (the “Original Purchaser”) the new gas-fired stove/insert manufactured by Hearthstone and purchased by the Original Purchaser (referred to as the “Stove” for simplicity) against any of the occurrences listed in this document that result from defects in material or workmanship. All obligations of Hearthstone under this document commence on the date the Original Purchaser purchases the Stove (the “Purchase Date”).

LIMITED LIFETIME WARRANTY

Hearthstone warrants the following parts of the Stove against the following occurrences that result from defects in material and workmanship:

- All cast iron parts, including the cast iron heat exchanger – against breakage, cracking or burn-through.
- All stones – against cracking or breakage due to thermal stress, **excluding** surface and hairline cracks and scratches that do not affect the operation or safety of the Stove.
- Glass – against breakage due to thermal shock.

LIMITED FIVE-YEAR WARRANTY

Hearthstone warrants the following parts of the Stove against the following occurrences that result from defects in material and workmanship:

- Firebox and firebox baffle – against breakage, cracking or burn-through.
- Convective heat exchanger – against breakage, cracking or burn-through.
- Burners, air shutters and orifices – against breakage, cracking or burn-through.
- Ceramic logs – against breakage, cracking or burn-through.

This warranty expires on the fifth (5th) anniversary of the Purchase Date.

LIMITED THREE-YEAR WARRANTY

Hearthstone warrants the following parts of the Stove against the following occurrences that result from defects in material and workmanship:

- Gas train, including gas valve, millivolt wiring, spill switch, pilot assembly, thermopile, thermocouple, piezo igniter, and, if the Stove is a vent-free model, ODS system – against breakage or malfunction.

This warranty expires on the third (3rd) anniversary of the Purchase Date.

LIMITED ONE-YEAR WARRANTY

Hearthstone warrants the following parts of the Stove against the following occurrences that result from defects in material and workmanship:

- Enamel Finish – against peeling or fading, **excluding** chipping, mechanical abrasion, chemical abrasion or crazing.
- Gaskets and sealants – against breakage or deterioration.
- Accessories and electrical components such as blowers, switches and thermo discs, **excluding** venting components, hearth components, electrical components and other components or accessories used in conjunction with the installation of the Stove **not** manufactured, or supplied by Hearthstone – against breakage or malfunction.

This warranty expires on the first (1st) anniversary of the Purchase Date.

EXCLUSIONS

The warranties contained in this document do not cover, nor is Hearthstone responsible for:

1. Damage resulting from installation or operation of the Stove in a manner contrary to the owner’s manual.
2. Damage or non-performance resulting from faulty or incomplete setup, installation and start-up or mishandling, abuse, or misuse of the Stove, including but not limited to over-firing.
3. Damage resulting from installation, modification, alteration, repair or service of the Stove by any party other than Hearthstone or an authorized Hearthstone dealer (a “Dealer”).
4. Damage due to water or due to installation of the Stove in a damp or high condensation area.
5. Damage due to installation of the Stove in an atmosphere contaminated by damaging chemicals, including but not limited to chlorine, fluorine or salts.
6. Scratches on glass, enameled surfaces or stones due to mechanical abrasion.
7. Standard wear and tear of the Stove resulting from normal usage over time.

8. Damage, operational-related problems, or inadequate performance caused by site, installation or environmental conditions beyond Hearthstone's control, including but not limited to nearby trees, rooftops, buildings, wind, hills, mountains, inadequate or excessive venting, insufficient make up air, or negative air pressure whether or not caused by mechanical systems such as furnaces, exhaust fans, clothes dryers, etc.
9. A defect in any part of the Stove if the Original Purchaser fails to comply with Hearthstone's or a Dealer's request to ship the part or the Stove to Hearthstone or a Dealer, as the case may be.

THE WARRANTIES CONTAINED IN THIS DOCUMENT ARE EXCLUSIVE AND ARE GIVEN BY HEARTHSTONE AND ACCEPTED BY THE ORIGINAL PURCHASER IN LIEU OF ALL OTHER EXPRESS WARRANTIES AND ANY OBLIGATIONS, LIABILITIES, RIGHTS, CLAIMS, OR REMEDIES IN CONTRACT OR TORT, WHETHER OR NOT ARISING FROM HEARTHSTONE'S NEGLIGENCE, ACTUAL OR IMPUTED. ALL IMPLIED WARRANTIES, INCLUDING THE WARRANTIES OF MERCHANTABILITY AND FITNESS FOR A PARTICULAR PURPOSE, ARE GIVEN **ONLY** TO THE EXTENT REQUIRED BY FEDERAL OR STATE LAW. EXCEPT AS OTHERWISE REQUIRED BY STATE LAW, UPON THE EXPIRATION OF THE EXPRESS LIMITED WARRANTIES CONTAINED HEREIN, **NO** IMPLIED WARRANTIES, INCLUDING THE IMPLIED WARRANTIES OF MERCHANTABILITY OR FITNESS FOR A PARTICULAR PURPOSE, SHALL APPLY TO THE SUBJECT STOVE. **SOME STATES DO NOT ALLOW LIMITATIONS ON HOW LONG AN IMPLIED WARRANTY LASTS, SO THE ABOVE LIMITATION MAY NOT APPLY TO YOU.**

THE WARRANTIES CONTAINED IN THIS DOCUMENT EXTEND **ONLY** TO THE ORIGINAL PURCHASER OF THE STOVE WARRANTED HEREUNDER. THEY DO NOT EXTEND TO ANY SUBSEQUENT OWNERS.

UNDER NO CIRCUMSTANCES SHALL HEARTHSTONE BE LIABLE TO THE ORIGINAL PURCHASER OR ANY OTHER PERSON FOR ANY INCIDENTAL OR CONSEQUENTIAL DAMAGES, INCLUDING BUT NOT LIMITED TO DAMAGE TO PROPERTY OR PERSONAL INJURIES, WHETHER ARISING OUT OF BREACH OF WARRANTY, TORT, OR OTHERWISE, EVEN IF HEARTHSTONE HAS BEEN APPRAISED OF THE POSSIBILITY OF SUCH DAMAGES. **SOME STATES DO NOT ALLOW THE EXCLUSION OR LIMITATION OF INCIDENTAL OR CONSEQUENTIAL DAMAGES, SO THE ABOVE LIMITATION OR EXCLUSION MAY NOT APPLY TO YOU.**

QUALIFYING FOR WARRANTY COVERAGE

To obtain performance of any obligation under this document, the Original Purchaser must, **within the applicable warranty time period**, contact Hearthstone, at the address listed in the Warranty Registration section below or your Dealer for instructions regarding the return of defective parts for repair, the return of the Woodstove for repair, or a Dealer service call. The Original Purchaser should refer to the Dealer network search engine contained on Hearthstone's Web site (www.Hearthstonestoves.com) to find a Dealer nearest the Original Purchaser's location.

REMEDY The remedy for any breach of the foregoing warranties will consist of repair or replacement, at Hearthstone's option, of any covered defect in the Stove. When the Original Purchaser contacts Hearthstone or a Dealer, Hearthstone or the Dealer, as the case may be, will instruct the Original Purchaser to **either** return the defective part, or the entire Stove (if needed), with shipping prepaid, to Hearthstone or a Dealer **or** allow a Dealer to make a service call at the place where the Stove is located. In the event the Original Purchaser refuses to allow a Dealer to make a service call, Hearthstone or a Dealer, as the case may be, will request that the Original Owner return the defective part, or the entire Stove (if needed), with shipping prepaid, to Hearthstone or a Dealer. **Notwithstanding any other provision of this document, the Original Purchaser shall pay for any travel fees and service charges related to a Dealer's service call.**

Parts: Hearthstone will replace defective parts covered by the foregoing warranties at no charge.

Labor: Within the first (1st) year after the Purchase Date, Hearthstone will pay for warranty labor performed by a Dealer at Hearthstone's published labor rates in effect at the time the labor is performed. Thereafter, the Original Purchaser is responsible for the cost of labor.

Shipping cost for parts: Within the first ninety (90) days after the Purchase Date, Hearthstone will pay for the shipping of Stove parts covered by any of the foregoing warranties to and from Hearthstone or a Dealer, as the case may be. Thereafter, the Original Purchaser is responsible for all shipping costs related to shipping Stove parts to and from Hearthstone or a Dealer, as the case may be.

Shipping cost for the Stove: Within the first (1st) year after the Purchase Date, if the Original Purchaser is instructed to return the Stove to Hearthstone or a Dealer for repair, Hearthstone will pay fifty percent (50%) and the Original Purchaser will pay fifty percent (50%) of the **shipping** costs related to shipping the Stove to and from Hearthstone or a Dealer, as the case may be. Thereafter, the Original Purchaser is responsible for one hundred percent (100%) of all of the shipping costs related to shipping the Stove to and from Hearthstone or a Dealer, as the case may be. Notwithstanding any other provision of this document, in

no event will Hearthstone pay for any Dealer fees or other fees for pick up or delivery of the Stove returned for repair; the Original Purchaser shall be responsible for any such fees.

WARRANTY REGISTRATION

The Original Purchaser may send a completed and signed Warranty Registration Form, which is enclosed in the Stove warranty packet, to the following address:

**Hearthstone Quality Home Heating Products, Inc.
Warranty Department
317 Stafford Avenue
Morrisville, VT 05661-8695**

NOTE: SENDING IN THE SIGNED WARRANTY REGISTRATION FORM IS *NOT* A CONDITION OF WARRANTY COVERAGE OR HEARTHSTONE'S PERFORMANCE.