



hase[®] - Luno

(Model 8160)

Gas Fired Direct-Vent Heater OWNER'S MANUAL

INSTALLATION AND OPERATING INSTRUCTIONS



**PLEASE READ THIS ENTIRE OWNER'S MANUAL
BEFORE YOU INSTALL AND USE YOUR NEW
LUNO GAS HEATER. SAVE THIS DOCUMENT FOR
FUTURE REFERENCE.**

WARNING: Follow the information in these instructions exactly, if not, a fire or explosion may result causing property damage, personal injury or loss of life.

WARNING: Do not store or use gasoline or any other flammable vapors and liquids near this or any other gas appliance.

WHAT TO DO IF YOU SMELL GAS:

- Do not try to light any appliance.
- Do not touch electrical switches; do not use the phone in your building.
- Immediately call your gas supplier from a phone outside the structure. Follow your gas supplier's instructions.
- If you cannot reach your gas supplier, call the fire department or 911.

A qualified installer, service agency, or gas supplier must perform installation and service of this appliance. In the Commonwealth of Massachusetts, all installation of gas lines and gas fittings must be performed by a licensed gas fitter or licensed plumber.

AVERTISSEMENT: Assurez-vous de bien suivre les instructions donné dans cette notice pour réduire au minimum le risque d'incendie ou pour éviter tout dommage matériel, toute blessure ou la mort.

Ne pas entresposer ni utiliser d'essence ni d'autre vaperurs ou liquides inflammables dans le voisinage de cet appareil ou de tout autre appareil.

QUE FAIRE SI VOUS SENTEZ UNE ODEUR DE GAZ:

- Ne pas tenter d'allumer d'appareil.
- Ne touchez à aucun interrupteur. Ne pas vous servir des téléphones se trouvant dans le batiment où vous vous trouvez.
- Appelez immédiatement votre fournisseur de gaz depuis un voisin. Suivez les instructions du fournisseur.
- Si vous ne pouvez rejoindre le fournisseur de gaz, appelez le service dos incendies.

L'installation et service doit être exécuté par un qualifié installer, agence de service ou le fournisseur de gaz.

Information Sheet

Use this page to record all relevant information concerning the purchase, installation, and maintenance of your Luno Gas-Fired Direct-Vent heater. This information will facilitate servicing, purchase of replacement parts, and warranty claims (if necessary). Keep your original receipt in a safe place as proof of purchase.

Serial Number: _____

Fuel type (check one) _____ Natural Gas _____ Liquid Propane

Sold by: _____

Phone: _____ Date of Purchase: _____

Installed by: _____

Phone: _____ Date of Installation: _____

Gas Supplier: _____

Phone: _____

Read this Owner's Manual before installing or operating the Luno 8160 DV. Retain this manual for future reference.

SERVICE RECORD

Important - Verify proper operation after servicing!

| Date | Who Performed Work | Work Performed | Notes: |
|------|--------------------|----------------|--------|
| | | | |
| | | | |
| | | | |
| | | | |
| | | | |
| | | | |
| | | | |
| | | | |
| | | | |

WHAT:
Firebox Cleaning.....
Glass Cleaning.....

WHEN:
annually
as needed

WHAT:
Door Gasket.....

WHEN:
Replacement as needed

TABLE OF CONTENTS

| | |
|--|----|
| INTRODUCTION | 3 |
| SPECIFICATIONS:..... | 4 |
| OWNER'S INFORMATION | 5 |
| INSTALLER'S INFORMATION..... | 6 |
| ITEMS REQUIRED FOR INSTALLATION | 6 |
| SPECIFIED VENTING MANUFACTURER CONTACT INFORMATION | 6 |
| UNPACKING AND INSPECTION..... | 6 |
| INSTALLING THE LUNO | 7 |
| OPENING THE FRONT DOOR..... | 7 |
| INSTALLING THE DECORATIVE TOP STONE | 7 |
| VENTING INFORMATION..... | 10 |
| ELECTRICAL CONNECTIONS | 13 |
| GAS SUPPLY & CONNECTIONS..... | 14 |
| FIRE LOG PLACEMENT..... | 15 |
| LIGHTING THE UNIT FOR THE FIRST TIME | 16 |
| INITIAL ADJUSTMENTS..... | 17 |
| ROUTINE MAINTENANCE AND CARE | 19 |
| PARTS LIST:..... | 21 |
| BOLTING YOUR LUNO GAS STOVE TO A PERMANENT STRUCTURE | 21 |
| HIGH ALTITUDE INSTALLATIONS | 22 |
| TROUBLESHOOTING | 23 |
| RATING LABEL..... | 26 |
| HASE GAS-FIRED STOVE WARRANTY..... | 27 |

INTRODUCTION

Congratulations on your purchase of Hearthstone's Luno Model 8160 Gas-Fired Direct Vent heater. The Luno incorporates the latest in balanced vent gas technology, which will provide you with clean, efficient heat for years to come. Combustion air comes directly from the outside of your home to the sealed firebox system, eliminating the potential for annoying back drafts or other problems associated with home depressurization.

The Luno will provide you with years of practical and convenient service. However, as with any gas appliance, the unit must be properly and safely

installed and maintained by qualified service personnel to ensure safe and trouble-free operation.

READ THIS OWNER'S MANUAL

Operate and maintain this gas heater according to the instructions in this manual. For your safety, and years of trouble free operation, read this manual in its entirety. By following a few simple safety precautions and by performing minimal maintenance, the unit will remain appealing while providing years of quality performance.

WARNING: ENSURE ONLY AN NFI CERTIFIED SERVICE TECHNICIAN INSTALLS, AND REPAIRS THIS APPLIANCE. A QUALIFIED SERVICE TECHNICIAN MUST INSPECT THE APPLIANCE BEFORE USE, AND AT LEAST ANNUALLY. MORE FREQUENT CLEANING MAY BE REQUIRED DUE TO EXCESSIVE LINT FROM CARPETING, BEDDING MATERIAL, PETS, ETC. IT IS IMPERATIVE THAT THE CONTROL COMPARTMENTS, BURNERS, AND CIRCULATING AIR PASSAGES OF THE APPLIANCE ARE KEPT CLEAN AND FREE OF OBSTRUCTIONS. (S'ASSURER QUE LE BRÛLEUR ET LE COMPARTIMENT DES COMMANDES SONT PROPRES. VOIR LES INSTRUCTIONS D'INSTALLATION ET D'UTILISATION QUI ACCOMPAGNENT L'APPAREIL.)

WARNING: DO NOT OPERATE THIS APPLIANCE WITH THE GLASS, OR ANY PANEL REMOVED, CRACKED, OR BROKEN. DO NOT SUBJECT THE DOOR TO ABUSE, SUCH AS STRIKING OR SLAMMING SHUT. REPLACEMENT OF THE GLASS PANEL SHOULD BE DONE BY A LICENSED OR QUALIFIED SERVICE PERSON.

NEVER BURN PAPER, WOOD OR OTHER MATERIALS

This gas heater is designed to burn natural gas, or when converted, liquid propane (LP). Never burn any fuel not intended for use with this unit.

HOT SURFACES

Certain exposed surfaces of the Luno will reach high temperatures during normal operation. Clearances to combustibles must be maintained, as specified in the "Clearances to Combustibles" section of this manual.

Do not use this appliance if any part has been under water. Immediately call a qualified service technician to inspect the heater and to replace any part of the control system and gas control that has been under water. *(Ne pas se servir de cet appareil s'il a été plongé dans l'eau, complètement ou en partie. Appeler un technicien qualifié pour inspecter l'appareil et remplacer toute partie du système de contrôle et toute commande qui ont été plongés dans l'eau.)*

⚠ WARNING: THIS GAS APPLIANCE MUST NOT BE CONNECTED TO A CHIMNEY FLUE SERVING A SEPARATE VENTED APPLIANCE. NEVER VENT THE GAS HEATER TO OTHER ROOMS OR BUILDINGS. MASONRY CONVERSIONS KITS ARE AN ACCEPTABLE VENTING OPTION.

Due to high temperatures locate the appliance out of traffic and away from furniture, draperies, clothing and flammable materials. Alert children and adults to the hazards of high surface temperatures and to stay away to avoid burns to skin or clothing ignition. Ensure young children are carefully supervised when in the same room as the appliance. Do not place clothing or other flammable material on or near the appliance. *(Surveille les enfants. Garder les vêtements, les meubles, l'essence ou autres liquides à vapeur inflammables loin de l'appareil.)*

FIRE HAZARD

Do not store or use gasoline or other flammable vapors or liquids in the vicinity of this appliance. Locate the Luno out of traffic and away from furniture, draperies, clothing, and flammable material.

Certified for use by:

Board of State Examiners of Plumbers and Gasfitters
100 Cambridge Street, Room 1511
Boston, Massachusetts 02202

SPECIFICATIONS:

LISTED AS: Gas-Fired Direct-Vent Fireplace Heater
Model: Luno Direct-Vent Gas Fireplace Heater (#8160)
Testing Agency: Intertek Testing Services
Tested to: ANSI Z21.88b-2005/CSA 2.33b-2005, CGA 2.17-M91
Report No. 3092115-T4
Certified for US and Canada
Approved for Mobile Home Installation.

Luno Fuel and Output Specifications

| FUEL TYPE: | NG | LP |
|---|----------|-----------|
| INPUT RATING (Btu/hr) 0-2000 ft | 26,500 | 26,500 |
| INPUT RATING (Btu/hr) 2000-4000 ft | 26,500 | 26,000 |
| ORIFICE SIZE (DMS) 0-2000 ft | 38 | 52 |
| ORIFICE SIZE (DMS) 2000-4500ft | 38 | 53 |
| MANIFOLD PRESSURE - LO SETTING (in. W.c./kpa) | 1.2/0.3 | 3.3/0.8 |
| MANIFOLD PRESSURE - HI SETTING (in. W.c./kpa) | 3.5/0.87 | 10.0/2.48 |
| MINIMUM INLET PRESSURE - (in.w.c./kpa) | 5.0/1.24 | 11.0/2.88 |
| MAXIMUM INLET PRESSURE- (in.w.c./kpa) | 7.0/1.74 | 13.0/3.22 |
| MINIMUM INPUT RATING (btu/hr) | 16,000 | 15,000 |
| MAXIMUM OUTPUT (btu/hr) 0-2000 ft | 20,400 | 20,200 |

Figure 1 – Luno Dimensions

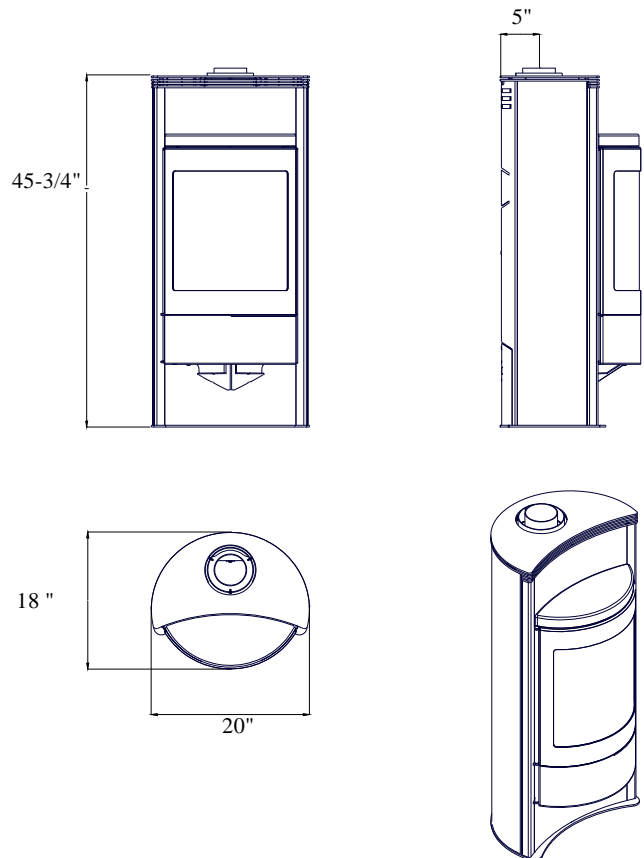

OWNER'S INFORMATION

The installation must conform with local codes or, in the absence of local codes, the current National Fuel Gas Code, ANSI Z223.1 (NFPA 54) or CAN/CGA B149 Installation Code. (*Installer l'appareil selon les codes ou règlements locaux, ou, en l'absence de tels règlements, selon les Codes d'installation CAN/CGA-B149.*)

Contact your dealer for any necessary warranty service.

This stove is warranted by:

Hearthstone Quality Home Heating Products, Inc®
317 Stafford Ave.
Morrisville, Vermont 05661

DAILY OPERATION

The Luno is easily operated by the homeowner once it is installed and adjusted by qualified service personnel. The unit can be controlled automatically via the programmable remote control, or manually by placing the Remote Control Receiver switch in the 'ON' position during the heating season. When using the remote T-stat transmitter (switch in the 'REMOTE' position), set it to the desired room temperature and the unit will cycle on and off as required. If you select the 'ON' position the unit will run (burn) regardless of room temperature. You can vary the rate of heat output by adjusting the variable output control located on the gas control valve to meet the heating requirements of the season. Choosing a low flame setting will result in longer burn cycles at a reduced output, while choosing a high flame setting will result in a shorter, hotter burn cycle. Through trial and error, the homeowner can select the optimum flame size for their setting and application.

During the summer non-heating season, switch the remote receiver to "OFF", and turn off the pilot. This will improve the overall efficiency of the unit as the fuel used by the pilot is wasted. When putting the unit back into service, follow the lighting instructions described on page 17.

When the unit is first lit, especially when cool, it is normal to experience some condensation on the inside of the window glass. This condensation will evaporate within the first few minutes of operation. If you note continuous condensation on the window glass or dripping water from any part of the unit or venting system (chimney), immediately discontinue operation of the unit and contact qualified service personnel.

Clean the area around, under, and behind the unit on a regular basis to prevent the accumulation of dust and lint.

The Luno requires minimal routine maintenance and care. Ensure the Luno is cool and off while cleaning, or servicing. Have qualified service personnel inspect the unit, and venting system once a year to insure that they are clean, free of obstructions, safe, and in good working order. If service or maintenance is required, ensure qualified service personnel perform it.

SERVICE CAUTION

If you believe your Luno is in any way, not performing properly, immediately discontinue operation until the unit is inspected and approved by qualified service personnel. Prior to servicing the unit, turn the valve control knob clockwise to "OFF". The unit should be cool prior to servicing and cleaning. Use of any components not supplied by Hearthstone on the stove voids all warranties. **Do not substitute components.**

⚠ **CAUTION: REPLACE ANY SHIELD, DOOR, OR SAFETY SCREEN COMPONENT REMOVED FOR SERVICING, PRIOR TO OPERATING THE UNIT.**

⚠ **WARNING: Failure to position the parts in accordance with these diagrams or failure to use only the parts specifically approved with this appliance may result in property damage or personal injury.**

Conditionally approved for purchased mobile home installation. This appliance may be installed in an aftermarket permanently located, manufactured (mobile) home, where permitted by local codes.

This appliance is only for use with the types of gas indicated on the rating plate (NG and LP). This appliance is factory set to burn Natural Gas (NG), but is easily converted for use with Liquid Propane (LP) with the included conversion kit. Only a qualified service technician should convert this stove.

Cet appareil peut être installé dans un maison préfabriquée (mobile) déjà installée à demeure si les règlements locaux le permettent.

Cet appareil doit être utilisé uniquement avec les types de gaz indiqués sur la plaque signalétique. Ne pas l'utiliser avec d'autres gaz sauf si un kit de conversion certifié est installé

INSTALLER'S INFORMATION

CODES

Adhere to all **local codes** or, in their absence, the latest edition of THE NATIONAL FUEL GAS CODE ANSI Z223.1 (NFPA 54) or CAN/CGA B149. Installation Code that can be obtained from:

AMERICAN NATIONAL STANDARDS INSTITUTE, INC.

1430 BROADWAY
NEW YORK, NY 10018
OR

NATIONAL FIRE PROTECTION ASSOCIATION, INC.

BATTERY MARCH PARK
QUINCY, MA 02269

A manufactured home (mobile) OEM installation must conform to the Manufactured Home Construction and Safety Standard, Title 24 CFR, Part 3280 (U.S.) or Standard for Manufactured Home Installation, ANSI/NCBCS A225.1 or Standard for Gas Equipped Recreational Vehicles and mobile Housing, CSA Z240.4.CAN/SCA Z240 MH (Canada). *(Installer l'appareil selon les codes ou règlements locaux, ou, en l'absence de tels règlements, selon les Codes d'installation CAN/CGA-B149.)*

ITEMS REQUIRED FOR INSTALLATION

- * External regulator
- * Piping which complies with state and local codes
- * Pipe sealant approved for use with fuel gas (resistant to sulfur compounds)
- * Manual shutoff valve
- * Sediment trap (see page 14)
- * Tee joint
- * Pipe wrench
- * Phillips head screwdriver
- * 7/16-inch wrench
- * Other parts as required by state or local code
- * Safety Glasses
- * Gloves

PACKING LIST

- 1-Luno Gas-Fired Heater
- 1-Set of Decorative Fire logs
- 1-Bag Platinum Embers
- 1-Decorative Top Stone
- 1-Owner's Manual
- 1-Warranty Validation Form
- 2-Accessory box
- 1-Touch up paint
- 1-Venting/stove connector
- 1-Remote Control Receiver
- 1-Remote Control Thermostat
- 1-Mobile home bolt down kit

Note: Vent kits and components are supplied separately. Failure to use the venting components specified by Hearthstone QHHP, Inc. will void your

warranty and could result in inefficient or unsafe operating conditions.

SPECIFIED VENTING MANUFACTURER CONTACT INFORMATION

Simpson

www.duravent.com/
(800)835-4429
customerservice@duravent.com

American Metal Products

AmeriVent
www.americanmetalproducts.com/vent/amerivent.htm
1-800-423-4270
info@americanmetalproducts.com

Selkirk Corporation

http://www.selkirkinc.com/
1.800.992.VENT (8368)
sales@selkirkinc.com
custsvc@selkirkinc.com

Security Chimneys International Limited

Secure Vent
www.securitychimneys.com/pages/chimneys

UNPACKING AND INSPECTION

Unpack and Inspect for Damage -

The Luno is packaged to withstand shipment without damage. However, damage can still occur during transit; so take care to inspect for damage when unpacking and installing the unit. If any damage or missing parts are detected, immediately contact your dealer. **Do not install, or put into service, a damaged or incomplete heater.**

The Luno requires a pilot shield. This shield is shipped with the unit. Ensure the shield is installed over the pilot with the open end to the left (when you are facing the front of the unit).

Inspect the Luno for visible or concealed damage. The unit should appear to be square and true. The metal parts should be smooth and free of bends and dents. The painted surfaces should be free of scratches flaking, or blemishes. If visible or concealed damage is found or suspected, contact your dealer for instructions.

Always use great care when handling the decorative fire logs, as they are fragile and will break if handled roughly. If a broken log is encountered, contact your dealer for replacement logs. Otherwise, set the logs aside until called for during the installation.

INSTALLING THE LUNO

HEARTH REQUIREMENT/FLOOR PROTECTION

The Luno may be placed directly on a non-combustible surface or wood floor. When installing the Luno on carpet, vinyl, or any other combustible floor other than wood flooring, it must be installed on any non-combustible or wood panel extending the full width and depth of the stove.

CLEARANCE TO COMBUSTIBLES

Due to high surface temperatures, install the unit out of traffic and away from furniture and draperies. Do not place clothing and other flammable material on or near the heater. When positioning the unit always maintain adequate clearances around air openings into the combustion chamber and allow for adequate ventilation. You must maintain minimum clearances to combustibles as shown in the illustrations of this section.

Ensure you consider the need for access to the gas control valve access door on the front of the unit as well as full access for periodic cleaning and servicing.

Caution: These clearances represent *minimum* distances in all cases, which, through testing in an independent laboratory to ANSI and CSA standards, will prevent fire or spontaneous combustion. We do not control the combustible materials exposed to heat by this product; therefore, an assessment must be made by the installer to prevent consequential damage of walls and flooring.

OPENING THE FRONT DOOR

In order to gain access to the firebox you must open the front door. The door is held closed with two machine screws, one on the top above the door, and one below the lower right corner of the door. To access these screws you must remove both the top stone and open the lower control access door located just below the front door. Do not remove the stone leveling screw containing the brass lock nut. Use the

provided tool to release the pressure on the screws before removal. Remove the mounting screw using a 4mm or 5/32" Allen wrench. **Replace these screws when the door is closed for operation; the door will not seal without them.** Use the provided tool to apply pressure on the door seal before installing the screws (see Figure 2).



Figure 2 – Door Assist Tool

INSTALLING THE DECORATIVE TOP STONE

Remove the top stone from the packaging carefully. Despite the mass of the piece of soapstone, it will break if dropped. Locate the hole drilled in the bottom of the stone. This hole will determine the bottom and front of the stone. Place the stone on the platform above the door accordingly. Adjust the stone so it has an even gap all around the back against the stove wall.

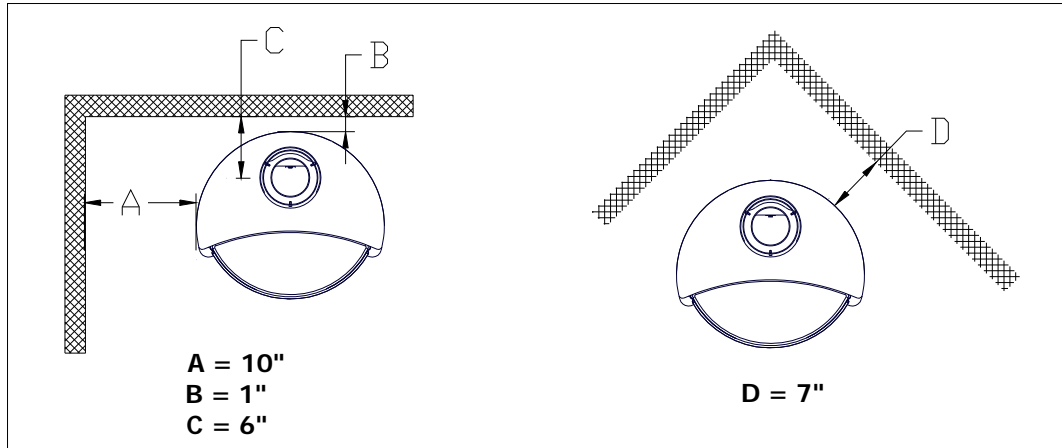

Figure 3 - Clearance to Combustibles

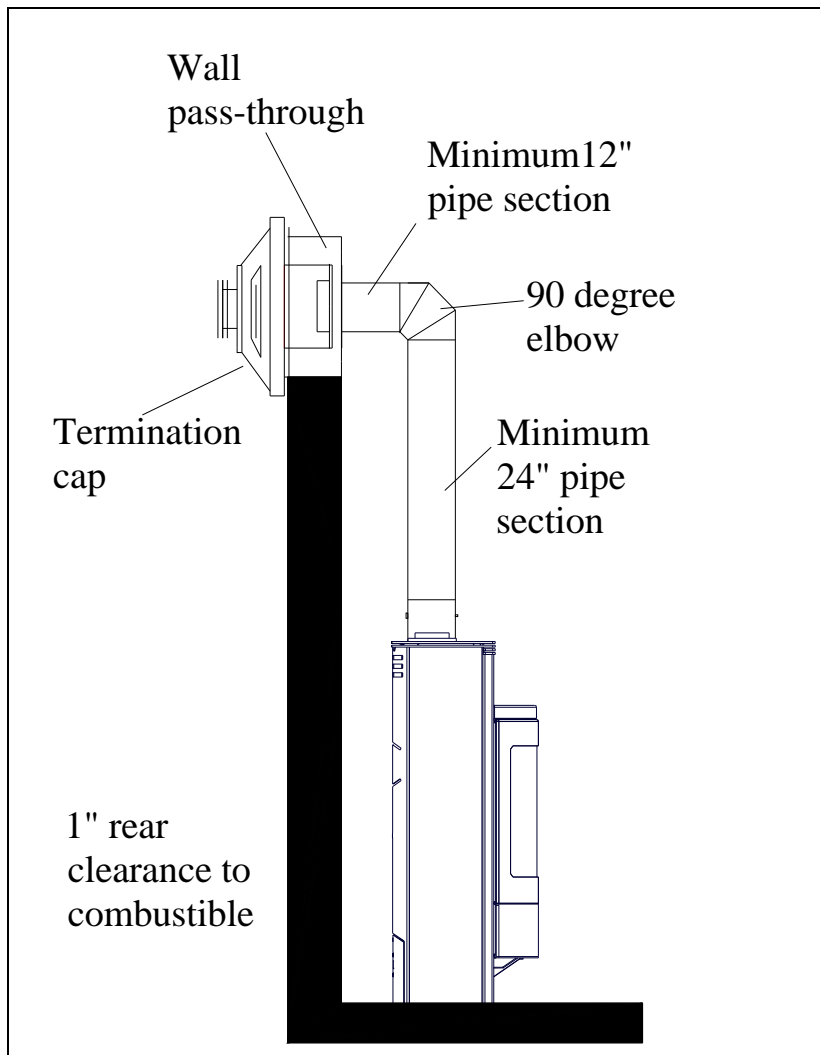
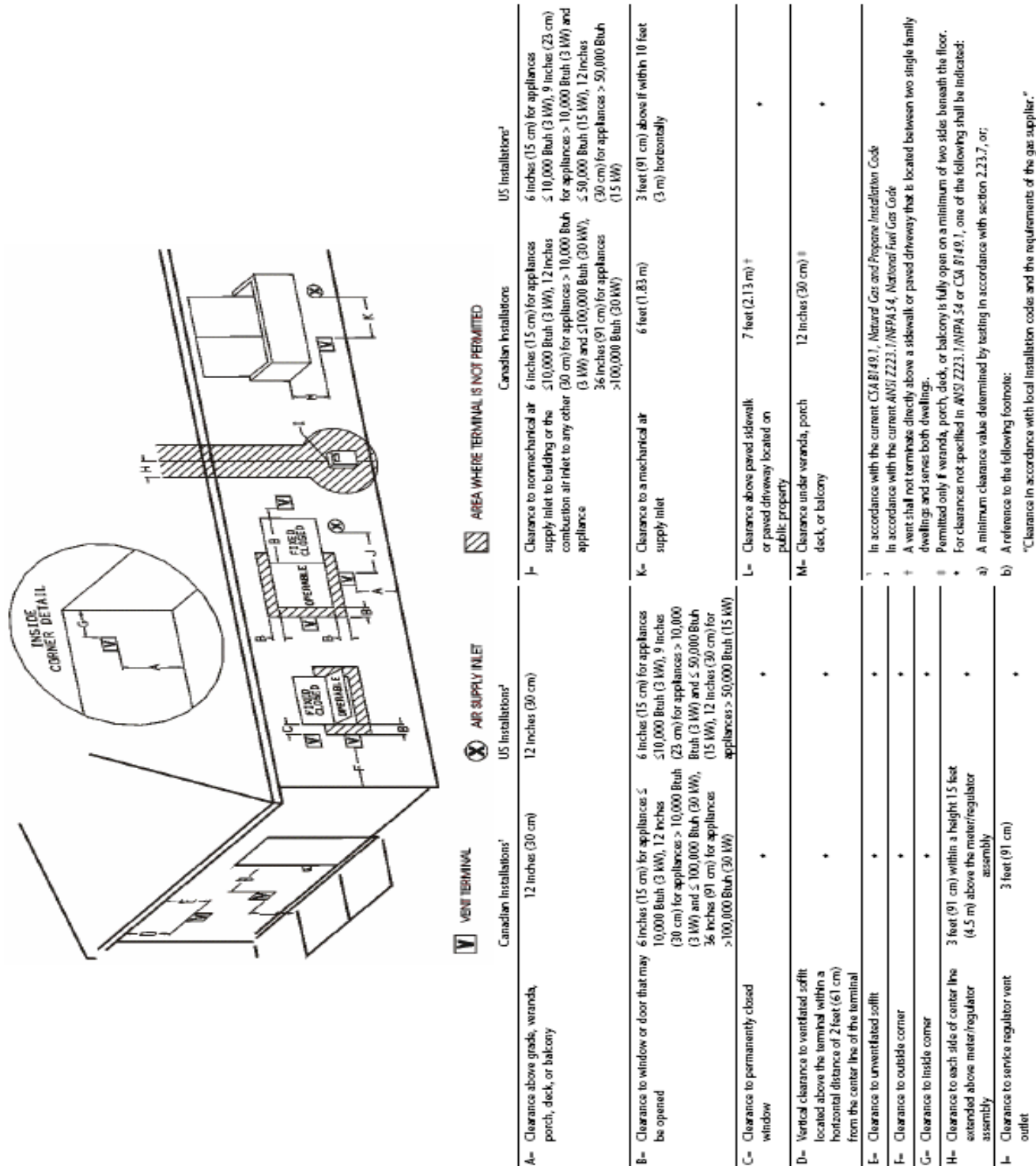

Figure 4 - Minimum Vent Configuration and Clearances

Acceptable Direct-Vent TERMINATION Cap locations.

Figure 1: Termination Location & Clearances



VENTING INFORMATION

VENT CONNECTION

1. The Luno Direct Vent is approved for installation only with the vent connecting components listed; Simpson Dura-Vent Direct Vent GS, AmeriVent Direct, Selkirk Direct Temp™ or Secure Vent systems. Use the following instructions along with the pipe manufacturer's instructions to complete the installation.
2. Install the vent system according to the manufacturer's instructions.

RESTRICTION PLATE

There is a vent restriction plate that adjusts the flow rate of exhaust gases. This ensures proper flame characteristics and efficiency for the wide variety of vent configurations. Controlling the draft also changes the aesthetics of the flame. The restriction plate consists of a rotating shutter in the flue connector. This shutter is attached to a rod that protrudes through the back of the pipe. This rod has a lock nut attached. On the very end of the rod is an indicator slot. This slot shows the relative position of the restrictor shutter. If the slot is pointing up and down (12+ 6 o'clock position) the restrictor is open. If it is pointing left and right (9+3 o'clock, the restrictor is in the closed position. The restriction plate has unlimited settings. Depending on the vent configuration, you may be required to adjust the restriction plate position.

Once the desired position is reached, use a 7/16" wrench to lock down the hex nut.

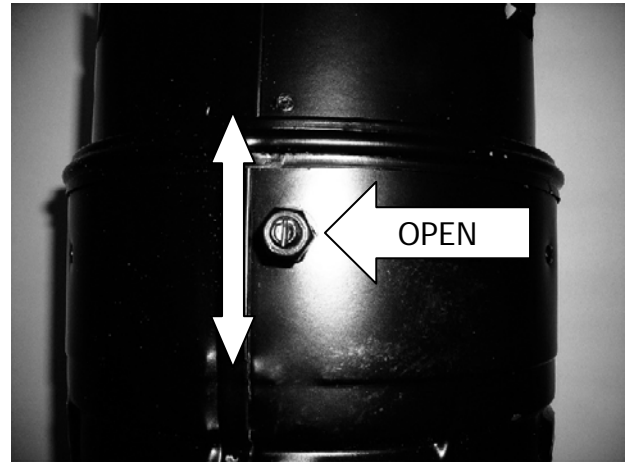

Figure 2: Restrictor in open position

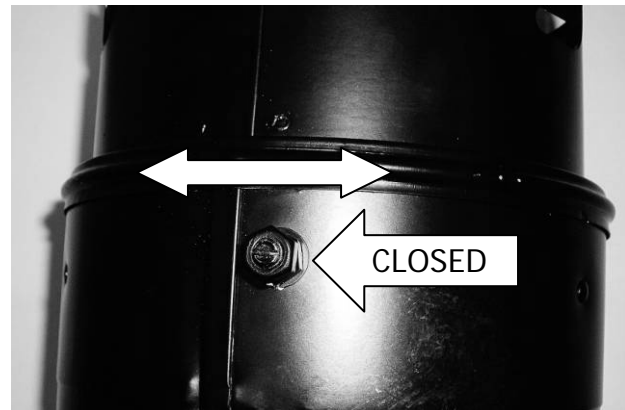
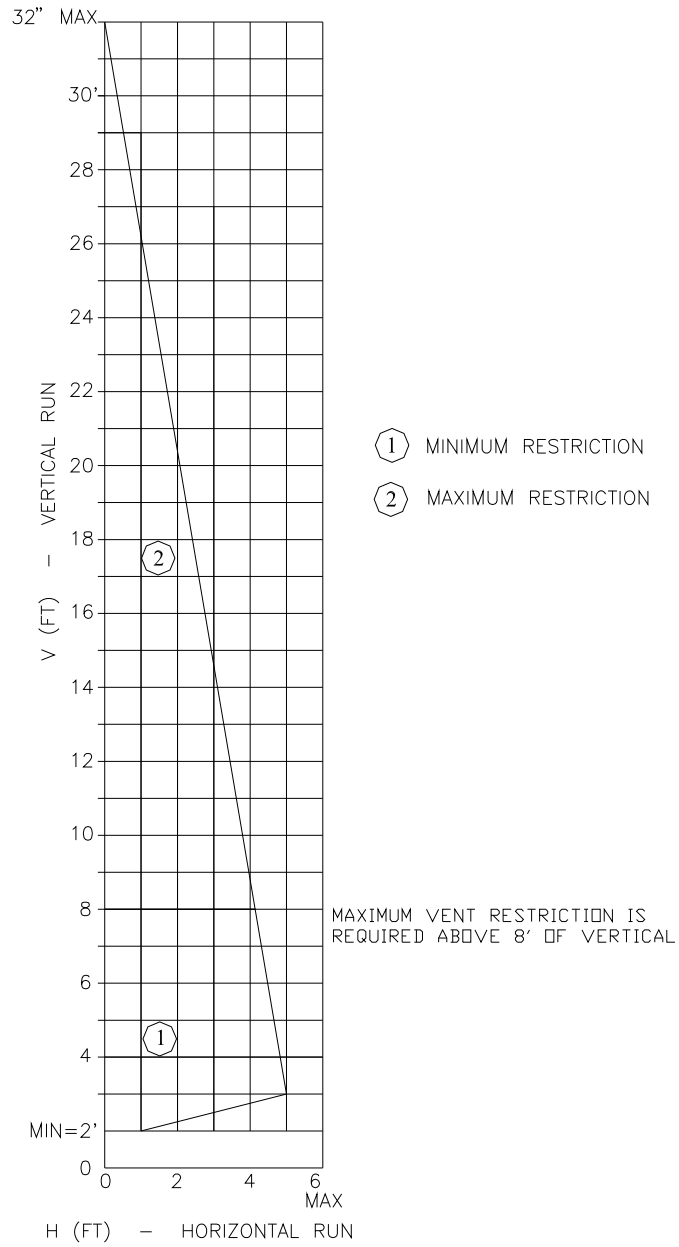

Figure 3: Restrictor in closed position



NO RESTRICTOR PLATE REQUIRED UNDER 5' VERTICAL

NO VENTING UNDER 2' VERTICAL

NOTE: These positions are based on lab results, and can have some variance.

Figure 4: Venting Configurations & Restriction Settings

VENTING COMPONENTS & CONFIGURATION

Do not vent the Luno jointly with any other solid fuel or gas appliance. Vent the Luno directly to the outside of the building using a proper termination as listed in this manual. The only types of venting pipe approved for use with your Luno Direct-Vent stove is Simpson Dura-Vent's GS, AmeriVent Direct, Selkirk Direct Temp™ and Secure Vent Direct-Vent Pipe. The venting configuration diagram is shown in *Figure 6*. After determining the proper venting configuration for your stove, select the vent system that will accommodate your installation.

⚠ **Caution:** Ensure there is no wiring or plumbing in the chosen location.

⚠ **Caution:** Do not recess venting terminations into a wall or siding.

Note: If further direction is needed for installation, please refer to the venting instructions, which are provided with the venting components.

Acceptable Direct-Vent Termination Cap Locations

The vent/air intake termination clearances above the high side of an angled roof are as follows:

| Roof Pitch | Feet | Meters |
|----------------|------|--------|
| Flat to 6/12 | 1 | 0.3 |
| 7/12 to 9/12 | 2 | 0.6 |
| 10/12 to 12/12 | 4 | 1.2 |
| 13/12 to 16/12 | 6 | 1.8 |
| 17/12 to 21/12 | 8 | 2.4 |

Listed are Simpson Dura-Vent, AmeriVent Direct, Selkirk Direct Temp™ and Secure Vent components acceptable for installation, along with the minimum venting kit available. The venting system must be comprised of the appropriate venting components as specified.

APPROVED VENTING SYSTEM COMPONENTS

(The following are components that are available, BUT NOT necessary for all installations)

| | |
|-----------------------------|-----------------------------------|
| 90° Elbow | Vertical Vent Cap |
| 45° Elbow | Horizontal Vent Cap |
| 6" Straight | Vinyl Siding Standoff 4" x 6 5/8" |
| 9" Straight (Simpson only) | |
| 12" Straight | Round Ceiling Support |
| 24" Straight | Thimble Covers |
| 36" Straight | Wall thimble |
| 48" Straight | 36" Snorkel |
| 11"-14 5/8" Adjustable Pipe | |

CHIMNEY LINER SYSTEM

Direct-Vent Chimney Liner Termination Kit
Chimney Liner Flex
Co-Linear Flex Connector

Co-Axial to Co-Linear Appliance Connect (**Masonry approved, not to exceed 16'** measured from the stove top)

MINIMUM VENT KIT

Vent connector (Provided with unit)

24" Straight

90 degree elbow

12" Straight

Wall Thimble Cover

Wall Thimble

Horizontal Vent Cap

⚠ **Dry fit your venting and take a measurement. Pipe dimensions will vary by manufacturer and supplier.**

INSTALLATION INSTRUCTIONS FOR THE STANDARD HORIZONTAL TERMINATION MINIMUM VENTING KIT

1. Install the 24" straight section on top of the vent connector.
2. Place the 90-degree elbow on the 24" section. Facing the direction expected to penetrate the wall.
3. Attach the 12" straight section to the 90-degree elbow. Move the stove and pipe assembly backwards until the 12" straight is flush against the wall. Pull up on the pipe to ensure that there is a 1/4" per foot rise coming out of the stove to the wall.
4. Draw a circle around the pipe. Use the center of this circle as the center point of the 10" x 10" square wall pass through. Cut and frame the wall pass through opening.
5. Place the interior wall thimble into the 10" x 10" wall pass through. Secure it with 4 screws (not provided). Install the exterior portion of the thimble in similar fashion, overlapping the 2 sections.

⚠ **Caution:** For buildings with vinyl siding, install a vinyl siding standoff between the vent cap and the exterior wall.

6. Install the horizontal vent termination on the outside of the wall. Ensure both of the retaining straps extend through interior wall thimble. Before attaching the vent termination to the outside of the house, run a bead of non-hardening mastic around its' outside edges to ensure a good seal between it and the wall. **Ensure the arrow on the end cap points up.** Secure the cap to the wall with appropriate screws.
7. Move the stove and vent pipe into position. Make sure the 12" vent pipe extends into the horizontal vent cap a minimum of 1-1/4". Secure the vent using the straps from the horizontal vent termination to the interior 6" pipe with 2 sheet metal screws, keeping the screws as close to the wall thimble as possible. Bend or cut any excess strapping, so that it is not visible after the installation is complete.

ELECTRICAL CONNECTIONS

NOTE: Open the valve compartment door on the lower front of the unit to access electrical and gas connections.

REMOTE CONTROL THERMOSTAT

The Luno 8160 comes equipped with a programmable ON/OFF/Thermostat remote control. We recommend the use of the thermostatic remote for more comfortable performance, however you may still override the thermostat by setting the switch to "ON". The thermostat controls the unit by "calling for heat." The thermostat turns the unit on when the room is cold, and turns the unit off once the room is warmed sufficiently. If desired, you can use any wired wall thermostat in place of the remote. You cannot use both the remote and a wall thermostat simultaneously.

REMOTE THERMOSTAT PLACEMENT

Place the thermostat transmitter in the same room or living space as the unit. Since the transmitter is the device measuring the temperature, you will want to keep it off the floor and away from any influences that

may cause the temperature in the vicinity of the thermostat to be unrepresentative of the room temperature in general. Such influences might include strong lighting, a heater vent from the central heating system, or a nearby sunny or drafty window.

Do not place the thermostat transmitter directly behind or too close to the unit, otherwise heat from the unit will immediately satisfy the thermostat and turn the unit off.

WIRING INSTRUCTIONS

CAUTION: Label all wires prior to disconnection when servicing controls. Wiring errors can cause improper and dangerous operation. Verify proper operation after servicing. *(Attention: Au moment de l'entretien des commandes, étiquetez tous les fils avant le débranchement. Des erreurs de câblage peuvent entraîner un fonctionnement inadéquat et dangereux.)* The proper location of wire connections is shown in *Figure 7*.

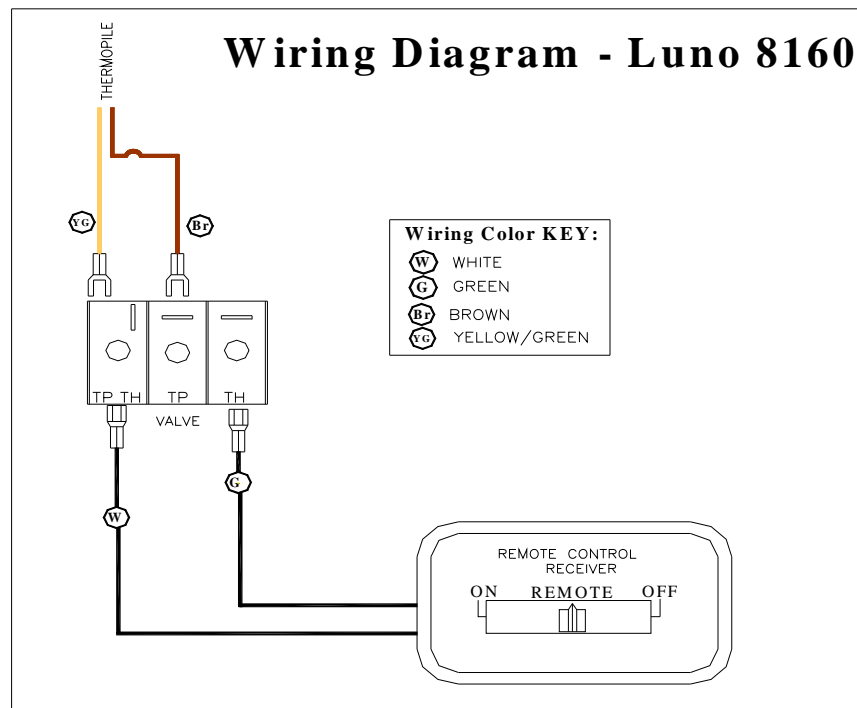

Figure 5: Luno 8160 Wiring Diagram

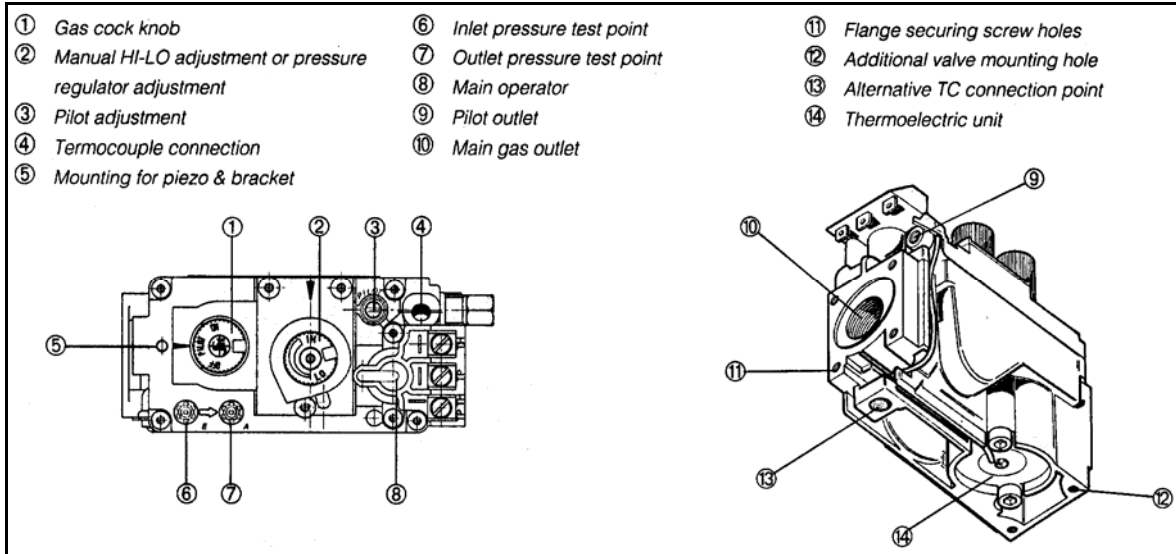

Figure 6: Gas Control Valve

GAS SUPPLY & CONNECTIONS

NOTICE: A qualified technician must connect the heater to the gas supply and leak test the unit before it is approved for use. Consult all codes.

WARNING: THE UNIT MUST BE INSTALLED AND CONNECTED IN ACCORDANCE WITH LOCAL CODES, OR IN THE ABSENCE OF LOCAL CODES, WITH THE MOST CURRENT EDITION OF THE NATIONAL FUEL GAS CODE ANSI Z223.1 (NFPA 54) OR CAN/CGA B149 INSTALLATION CODE.

NFPA Code and Hearthstone require the use of a dedicated sediment trap just upstream of the unit. Damage to the valve or other components, due to the lack of a sediment trap (*figure 10*), are not covered by warranty.

GAS CONNECTIONS

The gas supply connection is made to the Luno's gas control valve at the middle, lower rear of the stove, using a 3/8" male NPT fitting. The supply line should be 1/2" diameter, or appropriately sized to provide a sufficient gas supply to meet the maximum demand of the unit without undue loss of pressure. We recommend a flexible line to avoid undue mechanical load on the valve and to ease thread alignment, but refer to local codes.

CAUTION: Check Gas Type!

GAS SUPPLY

Isolate the Luno from the gas supply piping system by closing its individual manual shutoff valve during any pressure testing of the gas supply piping system at test pressures equal to or greater than 1/2 psig. Disconnect the

Luno and its individual shut-off valve from the piping system when testing the valve and connections at pressures equal to, or greater than 1/2 psig.

GAS PRESSURE ADJUSTMENT

NOTE: A QUALIFIED TECHNICIAN MUST PERFORM THIS PROCEDURE!

Once connected to the gas supply, the supply line and manifold gas pressures must be tested. The supply line pressure is tested, to ensure it meets the minimum gas supply pressure as listed in the Specifications for the type of fuel in use (natural gas or LP), by connecting a manometer to the supply line and adjusting the incoming pressure if necessary to meet the required supply line pressure as listed in specifications. The manifold pressure tap on the gas control valve, refer to *Figure 8* for location.

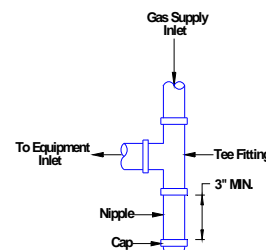

Figure 7: Typical Sediment Trap (required in all installations)

FIRE LOG PLACEMENT

CAUTION: Fragile! Handle log set with care. Always wear gloves and safety goggles while handling the log set.

Place only the Fire log set supplied with the Luno in the firebox. Do not place any other logs, wood logs, or other materials in the firebox. If the log set is damaged or broken contact your dealer for replacement. Only replace the logs with the same approved replacement parts. These components affect the combustion quality and safety of the heater. The Fire log set is durable; however, they will break if subjected to rough or improper handling. Exact positioning of the log set is required in order to obtain a pleasing flame pattern and efficient combustion. Incorrect log placement may cause carbon build-up; excess thermal stress on the log set and stove parts, reduced efficiency, and high levels of carbon monoxide. If the log set does not fit into the firebox exactly as outlined, contact your dealer for assistance.

INSTALLATION OF THE FIRE LOG SET

Follow the order of the following photos in order to install the log set:

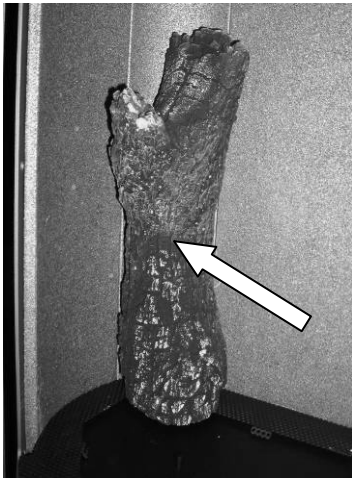

1. Install the rear left log in the rear left corner.

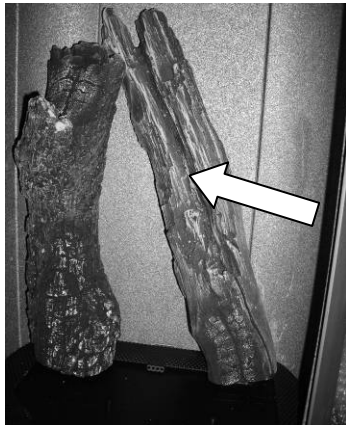

2. Locate and install the rear right log.

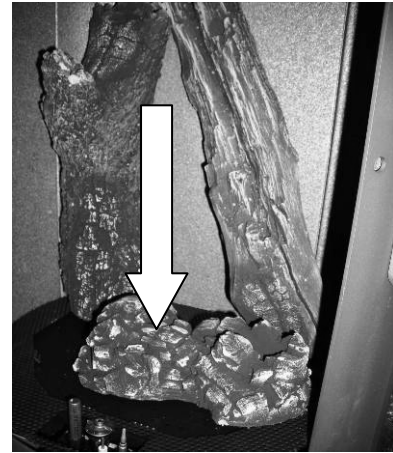

3. Locate and install the ember pile. This will have two holes underneath that fit over two posts in the center of the burner top.

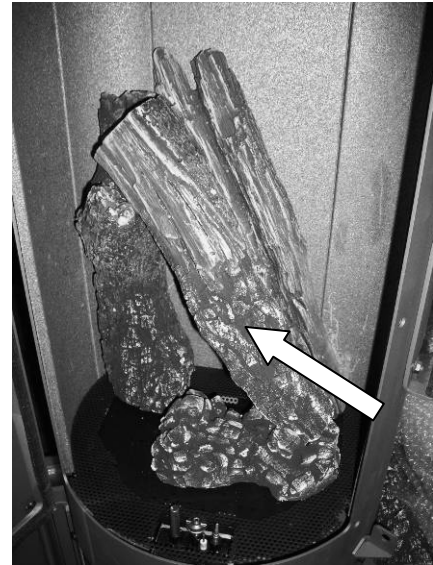

4. Install the Center log. The bottom tip rests in the cradle of the ember pile.



5. Place the left front ember strip in front of the pilot assembly.

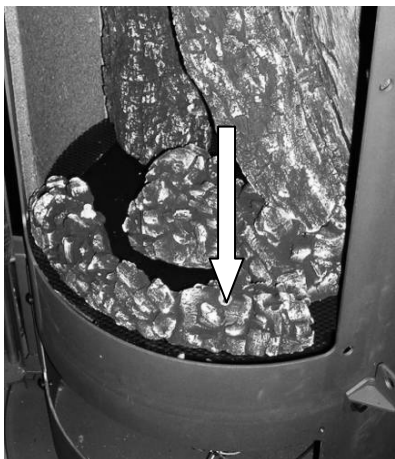

6. Slide the Right front ember strip next to the Left ember strip. The two fit together to hide the seam.

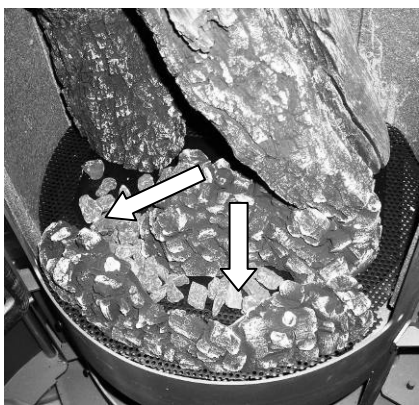

7. Sprinkle the charcoal embers over the burner ports. Ensure that you leave the ports open over the pilot and where the main burner ignites.

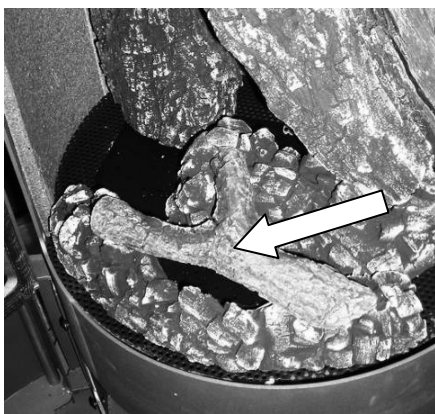

8. Place the twig as shown.
9. Place Platinum Bright embers randomly and sparingly over the logs and burner.

REMOVAL OF LOG SET

- CAUTION: THE FIRE LOG SET RETAINS HEAT AND CAN BE VERY HOT! ALLOW 2 TO 3 HOURS AFTER PILOT LIGHT IS TURNED OFF BEFORE HANDLING.**

To remove the Fire log set, follow the Installation of Log Set instructions in the reverse order.

LIGHTING THE UNIT FOR THE FIRST TIME

WARNING: If you do not follow these instructions exactly, a fire or explosion may result causing property damage, personal injury or loss of life.

CAUTION: Lighting the Luno for the first time and adjustments to the unit should be performed by qualified service personnel.

This appliance is designed only for use with the type(s) of fuel gas indicated on the rating plate. This appliance is not convertible for use with other gases, unless a certified kit is used.

Cet appareil doit être utilisé uniquement avec les types de gaz indiqués sur la plaque signalétique. Ne pas l'utiliser avec d'autres gaz sauf si un kit de conversion certifié est installé.)

SMOKE AND FUMES WARNING

When lit for the first time, the Luno will emit some smoke and fumes. This is normal "off-gassing" of the paints and oils used in the manufacturing and assembly of the unit. Open windows to vent the room if necessary. The off gassing and fumes will subside after the first 10 to 20 minutes of operation.

ODORS AND IMPURITIES

A heater of this type may produce other odors during heater operation due to impurities that may exist in the immediate area. Sources of impurities can be cleaning solvents, paint solvents, cigarettes, candles, smoke, pet hair, dust, adhesives, new carpet, and/or textiles. Such odors usually dissipate. However, opening a window or otherwise providing additional ventilation to the area can alleviate the condition quickly. If any odor persists, remove potential sources, or contact your dealer or an authorized service technician.

PILOT LIGHT

The Luno has a piezoelectric spark igniter (the black push button located next to the gas control valve behind the valve access door), which ignites the pilot light by means of a spark at the pilot light assembly.

DO NOT LIGHT PILOT OR BURNER BY HAND

Never attempt to light the pilot or main burner by hand with a match or lighter. If, after repeated attempts, the pilot light fails to light using the piezoelectric igniter, discontinue operation; turn off the gas at the gas control valve, and immediately contact qualified service personnel for assistance.

PREPARE FOR LIGHTING

Prepare for the lighting procedure by adjusting the thermostat (if equipped) to its lowest setting or OFF position. If the gas control knob is not in the OFF position, turn the knob fully clockwise to OFF. Locate the variable output control knob and turn it fully clockwise to the highest setting.

Prior to lighting the unit for the first time, wait 5 minutes to allow any residual gas within the unit to dissipate. Smell all

around the appliance area for gas. Be sure to smell next to the floor because some gases (LP) are heavier than air and will settle on the floor. If you do not smell gas after this five-minute period, proceed with the lighting procedure. If you do smell gas, **DO NOT** proceed with the lighting procedure. Instead, **immediately refer to the 'What to Do If You Smell Gas!' warning on the cover of this manual.**

🔥 NOTE: The valve control has an interlock device. After shutting off all gas flow, the pilot burner cannot be relit until the thermocouple has cooled, releasing the electromagnet (approx. 60 seconds). The gas control knob is designed to operate by hand. Do not use any tools during this operation. Damaged knobs may result in serious injury.

INITIAL ADJUSTMENTS

Once the Luno is set in place, connected and assembled as described in the "Clearances To Combustibles", "Venting Components & Configurations", "Electrical Connections", and "Gas Supply and Connections" sections of this manual, the unit is almost ready to light for the first time. The manufacturer tests each unit prior to shipment, so ignition should take place without failure. However, a number of small adjustments may be necessary to compensate for variations in gas pressure, altitude, and other factors particular to each installation.

VARIABLE OUTPUT CONTROL

The gas control valve is equipped with a variable output control. This control varies the rate of heat produced by the unit by varying the gas pressure to the TEK Burner. A combination of heat output and the thermostat setting affect the length of the burn cycle. If your stove cycles on and off too often, first try reducing the burn cycle by turning the HI/LOW knob, on the control valve, to a lower setting. Using the variable output control, the heat output of the unit can be reduced for mild fall and spring months, or maximized for the colder winter months. This adjustment can be made by the homeowner as necessary by turning the variable output control knob to "HI", "LO" or any setting in between.

LIGHTING INSTRUCTIONS

NOTE: The gas control knobs and the piezo igniter are located behind the control valve access door, under the front of the unit.

1. **STOP! Read the What To Do If You Smell Gas! Warning (on the cover of this manual). Ensure the front door is closed, and the lock screws are in place.**
2. Set the on/off/remote switch or thermostat to the "OFF" position.
3. Push in and turn the gas control knob clockwise to "OFF". (If not previously lit, the knob should be in this position.)
4. Wait (5) five minutes to clear out any gas. If you then smell gas, STOP! *Smell all around the appliance area for gas. Be sure to smell next to the floor because some gases are heavier than air and will settle on the floor. If you smell gas immediately follow the 'What To Do If You Smell Gas!' warning on the cover of this*

Manual. If you do not smell gas, proceed to the next step.

5. Turn gas control knob counter-clockwise to "PILOT".
6. Push in the control knob all the way and hold in. Immediately light the pilot with the gas lighter (push in and "click" the piezoelectric spark igniter button several times until lit). Continue to hold the control knob in for about 20 seconds after the pilot is lit. Release the knob and it will pop back out. The pilot should remain lit. If the pilot goes out, repeat the operation.

🔥 **If knob does not pop out when released, stop, shut off the gas supply to the heater and immediately call a qualified service technician or gas supplier.**

🔥 **If the pilot will not stay lit after several tries, turn the gas control knob "OFF" and call a qualified service technician or gas supplier.**

7. After the pilot lights, turn the gas control knob counter-clockwise to "ON".
8. If the ON/OFF/remote switch is set to "ON", the stove should now light. If the remote (or thermostat) is installed, set the ON/OFF/ remote switch to "remote" and program the remote to "ON". Then set the desired temperature.
9. Shut the gas control valve access door.
10. If "Remote" was selected, set remote to "ON" and set desired temperature setting. Normally, if Remote position was selected, the main burner is cycled on and off by the thermostat or the "on/off" switch located on the bottom of the thermostat body.

NOTE: When pressing/clicking the piezoelectric spark ignition button to light the pilot, watch through the glass (front) of the unit. Click the igniter button until a flame is visible at the pilot. Once the pilot is lit, continue to press on the gas control knob for another 20 seconds, then release. Ascertain that the pilot is still lit by looking through the front door. If lit, then turn the gas control knob fully counter-clockwise to the "ON" position. If the pilot fails to light, or if it went out due to a premature release of the gas control knob while depressed in the "PILOT" position, wait 60 seconds for the Interlock to release. Then repeat the lighting process as described in this section of the manual.

Once the pilot is lit, the gas control knob is been turned to the "ON" position, and the ON/OFF/Remote switch is turned to "ON", the main burner should light immediately. If you would like to use the thermostat and it is installed, switch the ON/OFF/Remote switch to thermostat. Turn the remote transmitter to "ON" and set it to a higher position so that it "calls" for heat in order to light the main burner (i.e. turns the unit on). Note that the remote thermostat controls the on/off cycling of the main burner, but the pilot remains lit regardless of the remote thermostat setting. The only way to turn the pilot off is to turn the gas control knob fully clockwise to the "OFF" position.

TO TURN OFF GAS TO APPLIANCE

1. Set the Remote thermostat to the "OFF" position or turn the ON/OFF/REMOTE switch to the "OFF" position.
2. If shutting the unit off for the non-heating season, turn the gas control knob fully clockwise to the "OFF" position. Do not force the knob to turn.

AIR SHUTTER

The air shutter is used to regulate the air-to-gas combustion mixture, which in turn influences the size and color of the flames. The air shutter is factory set in the general location needed for Natural Gas (NG), however, if the unit is not burning as well as it should, then the air shutter may need adjusting. The air shutter may need adjustment once the unit has been installed to compensate for variations in supply line pressure, restriction plate position, altitude, fuel gas type conversions, and other variables.

To determine if the air shutter needs adjustment, it is necessary to view the flame pattern with the variable output control knob at its highest setting. Allow the unit to operate for at least 10 minutes to allow the entire unit to reach temperature, and for the flame pattern to stabilize. Generally, the more air (open shutter) in the mixture, the bluer the flame. Less air (closed shutter) results in a more yellow flame, but too little air will result in incomplete combustion, low efficiency and a dirty burn. There are two simple guidelines to aid in determining the correct flame pattern:

- If the flame at the base of the logs is completely blue, the air shutter is possibly open too far;
- If the flame is dirty (sooty) or licks the top of the stove, the air shutter is possibly closed too far.

Some conditions cannot be corrected through air shutter adjustment; an adjustment must be made to the gas supply pressure or by changing the restriction plate location. Qualified service personnel must perform supply line/manifold gas line pressure adjustments and restrictor plate adjustments. Do not attempt to complete any part of the installation or adjustment of this unit unless technically qualified to do so.

AIR SHUTTER ADJUSTMENTS

The air shutter adjuster, located under the valve access door, at the lower front of the unit, is adjustable while the stove is burning. Under the burner assembly, but above the valve is the air shutter handle. It is a steel handle bent down for you to grasp. It uses a thumbscrew to lock the position of the shutter in place. **This handle and screw will get very hot during operation.** Loosen the thumbscrew and slide the shutter back and forth a couple of times to understand the "throw" of the shutter. Push the handle forward to close the air shutter. Pull it towards you to open the air to the unit. When the flame pattern is correct, tighten the locking nut without turning the screw. The air shutter is factory set and only a qualified gas technician should make adjustments.

Note: Very little movement is needed to substantially change the burn and flame patterns. Some conditions cannot

be corrected through air shutter adjustment; an adjustment must be made to the gas supply pressure. Supply line/manifold gas line pressure adjustments must be performed by qualified service personnel. Do not attempt to complete any part of the installation or adjustment of this unit unless technically qualified to do so.

PILOT ADJUSTMENT

The pilot light is preset by the manufacturer and should not need adjustment. However, you should perform a periodic visual check of the pilot flame. The pilot light flame should be large enough to engulf the thermopile and thermocouple located next to the pilot, but not so large as to create excessive noise or consume excessive gas (*Refer to figure 10*). If needed, the pilot flame is adjustable by means of the pilot light adjustment screw located on the gas control valve (*see figure 8*). Open the valve door to access the pilot adjustment screw. Note that the pilot flame must engulf the thermopile so that the thermopile can generate sufficient milli-voltage (325 to 500-mv) to power the gas control valve. The flame on the pilot should look like *Figure 10*. Controlling the Luno by the remote or wall-mounted thermostat may become erratic, nonexistent, or the unit may go out, if the pilot flame is too small or misdirected away from the thermopile.

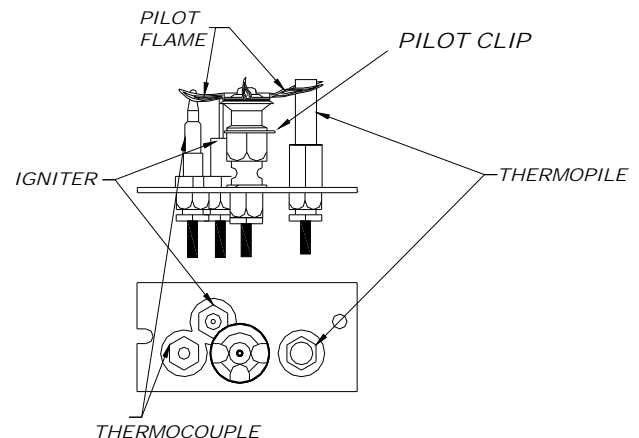

Figure 8: Pilot flame and assembly

WARNING

The control has an interlock device. If the stove was lit, then turned off, it will not relight immediately. After shutting off all gas flow, the pilot burner cannot be relit until the thermocouple has cooled, releasing the electromagnet (Approx. 60 sec.). The gas control knob is designed to operate by hand. Do not use any tools during this operation.

BURNER FLAME APPEARANCE

Once the unit is lit, observe the flame pattern and adjust as necessary. You should perform a periodic visual check of the burner flame. The burner flames can be adjusted by means of the air shutter. To determine if the burner flame needs adjustment, it is necessary to view the flame pattern with the variable output control knob at its highest setting (turn fully clockwise). Allow the unit to operate for 10 minutes enabling

the entire unit to reach temperature and for the flame pattern to stabilize. The flame pattern should be similar to the one shown in *Figure 11*. There are several guidelines to aid in determining if the flame pattern is correct:

1. The flame should not be dirty, smoky, sooty, or lick the top of the stove.
2. The flame should not rise off the burner; this is called "lifting".
3. Flames should not impinge heavily on the log set. They should "fit" through the pre-formed spaces designed in the log set.



Figure 9: Typical flame appearance

ROUTINE MAINTENANCE AND CARE

The Luno requires minimal routine maintenance and care. Ensure the Luno is cool and off when being cleaned, or serviced. Once a year, the unit, and venting system should be inspected by qualified service personnel to insure that they are clean, free of obstruction, safe, and in good working order. If service or maintenance is required, qualified service personnel should perform it.

WARNING: Do not substitute materials. For replacement parts, or for information about parts or service, contact your local Hearthstone dealer.

CLEANING

WARNING: Do not clean the unit when hot.

The unit should receive regular cleaning on, under, and around the stove to prevent the buildup of dust and lint. The exterior surfaces of the unit can be cleaned using soap, water, and a soft cloth. **Do not** use abrasive or chemical cleaners and take care not to scratch the glass or enamel finish (if so equipped) when cleaning the unit. The use of chemical wax based cleaners or polishes are not recommended due to the potential for discoloration of the stones, castings or enamel when the residues of the cleaners or polishes are exposed to heat. Excessive buildup of dust, spider webs, or room air contamination may cause odors when the stove is hot.

FIREBOX, PILOT, & BURNER ASSEMBLY

The firebox requires periodic cleaning to prevent the accumulation of dust, lint, and other debris. To clean the firebox, set the ON/OFF/REMOTE switch to the "OFF" position, and turn off the gas at the gas control valve. When the unit is cool, open the front door. Carefully remove the decorative log set, taking care not to damage the logs or chip the enamel cast iron. Clean the firebox and burner, and carefully vacuum the entire surface of the log set. Thoroughly vacuum the ports (holes) along the top of the burner, and the pilot assembly.

With the decorative logs out of the firebox; briefly light the unit. Check to insure a proper flame is burning from each burner port. The pilot flame should be large enough to engulf the thermopile and thermocouple as shown in *Figure 10*.

NOTE: Do not operate the unit for more than 1-2 minutes without the log set in place. Turn the unit off by setting the thermostat to "OFF", and turning the gas control valve off. Allow the unit to cool.

Check and clean any burner ports that are not burning, or not burning properly. Clean burner ports using a soft brush or vacuum cleaner. If the pilot flame height needs adjustment, it should be adjusted by qualified service personnel as described on *page 18*.

Complete the cleaning procedure by carefully placing the log set within the firebox. Re-install the glass assembly and front cast. Turn on the gas, light the unit and check for proper operation. Flame patterns should look similar to the flames in *Figure 11*. Regularly check to insure the area around the Luno is kept free from combustible materials, gasoline, and other flammable vapors and liquids. Check that the flow of combustion and ventilation air is not obstructed.

DOOR REMOVAL PROCEDURE:

The door is held closed with two machine screws, one on the top above the door, and one below the lower right corner of the door. To access these screws you must remove both the top stone and open the lower control access door located just below the front door. Do not remove the stone leveling screw containing the brass lock nut. Use the provided tool to release the pressure on the screws before removal. Remove the mounting screw using a 4mm or 5/32" Allen wrench.

1. Open the door fully, grasp the door securely and support it, remove the upper hinge pin.
2. Tilt the top of the door outward, and then lift the door up off the lower pin.
3. Place the door face down on a padded work surface. Use two rolled up towels, or similar, under the door to stabilize the curved door during maintenance.
4. Reverse steps 1 and 2 when remounting the door.

Reinstall the securing screws when the door is closed for operation; the door will not seal without them. Use the provided tool to apply pressure on the door seal before installing the screws.

GLASS REPLACEMENT PROCEDURES:

1. Follow the instructions included with the replacement glass kit.
2. Remove the door (see door removal procedure).
3. Remove the 12 screws from the glass retainer (use penetrating oil if necessary) – lift the retainer off the glass. Set aside for reinstallation.
4. Carefully lift the damaged glass out of the door and discard.
5. Remove any remaining glass and old gasket material.
6. Clean the screw holes and place a small amount of anti-seize compound in each one.
7. Place the gasketed new glass onto the door.
8. **Important! Center the glass** and ensure that the edges of the curved glass are parallel with the edges of the opening.
9. Check glass position again (centered, and parallel), then screw the glass retainer back on the door using a crisscross pattern. Tighten the screws no more than 1/8th of a turn after they seat. (The glass will break at this point if not positioned correctly. If the glass shifts too much to one side, you may see the gasket from the outside)
10. Apply a light film of anti-seize lubricant on the door's hinge pins if needed.
11. Install the door.
12. After 5 or 6 fires, check the glass retainer screws, and retighten if necessary.

Required Glass Kit: Part Number: 3300-201477 (Glass with gasket applied).

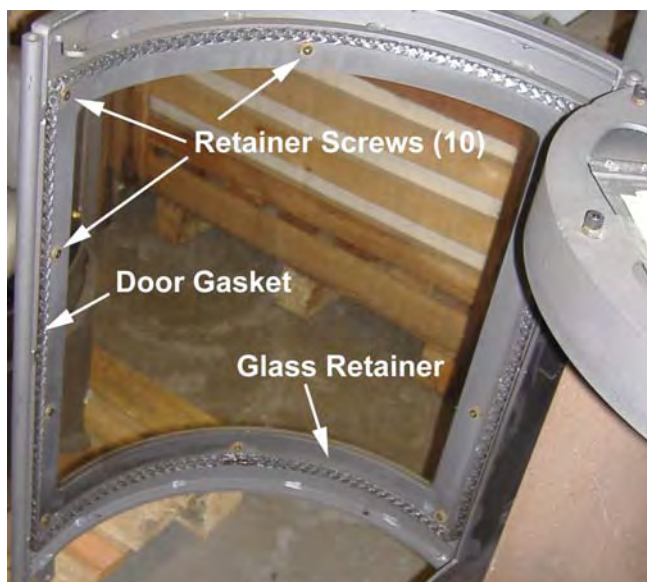

Figure 10: Door assembly

GLASS CLEANING

As fuel gas may contain some impurities; it will be necessary to clean the inside of the glass occasionally. Do not use abrasive cleaners. Scratching the glass will weaken the integrity of the glass. **Do not clean the glass when hot!** Allow the glass to cool and apply a mild window cleaning fluid. Special gas appliance window cleaner is available from your local Hearthstone dealer.

WARNING: Do not operate this appliance with the glass panel removed, cracked, or broken. Do not subject the door to abuse, such as striking or slamming shut. Replacement of the glass panel should be done by a licensed or qualified service person.

VENTING

The venting system should receive a periodic examination by a qualified agency. If the vent-air system is disassembled for any reason, re-install per the instructions provided in the venting section of this manual, being sure to reassemble and reseal the venting properly.

STONE

Occasional cleaning is all that is necessary to maintain the natural beauty of your stove's soapstone top plate. Clean the soapstone with water, any non-abrasive cleaner and a soft cloth. Wipe dust from the stone with a clean cloth. Do not use chemical agents to wash the stone; do not use waxes or any polishing agents on the stone. Soapstone is porous and will absorb most liquids, which can leave a stain, change the appearance, or result in odd odors when warm.

Take care not to scratch or chip the soapstone. Do not set items that can scratch or chip the stone on top of your stove. You can use 240 grit sandpaper to easily repair, or blend in minor scratches

Often, with use and over time, subtle earth tones of brown, red, and yellow may appear in the soapstone. This is a natural reaction in the soapstone. Surface or hairline fractures may also appear in the stone after a stove is used. Such changes are normal and do not affect the operation or the integrity of the stove and do not require replacement. If you observe a completely broken stone, contact your dealer for service.

PARTS LIST:

| Part # | Part Name |
|-------------------|----------------------------------|
| 7211-252 | BURNER PAN |
| 7211-253 | BURNER TOP PLATE |
| 7211-250 | VENTURI TUBE |
| 5800-240 | SHUTTER: PRIMARY AIR |
| 3160-181 | GASKET: FIREBOX BOTTOM |
| 3160-180 | BURNER GASKET |
| 3160-152 | PILOT GASKET |
| 3160-182 | VENTURI GASKET |
| 3170-150 | PLATINUM BRIGHT EMBERS |
| 7211-572 | REAR LEFT LOG |
| 7211-573 | REAR RIGHT LOG |
| 7211-574 | CENTER EMBER PILE |
| 7211-575 | CENTER VERTICAL LOG |
| 7211-576 | FRONT, RIGHT LOG |
| 7211-577 | FRONT, LEFT LOG |
| 7211-578 | TOP TWIG |
| 7211-517 | KIBBLES (4OZ) |
| 7211-401 | KNOB EXTENSION ON/OFF |
| 7211-402 | KNOB EXTENSION HIGH/LOW |
| 7211-370 | PILOT ASSEMBLY (NG) 3 port |
| 7200-338 | NG ORIFICE MAIN ORIFICE #38 SPUD |
| 91-56800 | LP CONVERSION KIT |
| 1141-820-128-0102 | TOP STONE PLATE |
| 5120-020 | PILOT SHIELD |
| | |

WARNING: *Do NOT SUBSTITUTE MATERIALS.* FOR REPLACEMENT PARTS, OR FOR INFORMATION ABOUT PARTS OR SERVICE, CONTACT YOUR AUTHORIZED HEARTHSTONE RETAILER. FOR THE NAME OF THE AUTHORIZED RETAILER NEAREST TO YOU, VISIT OUR WEBSITE WWW.HEARTHSTONESTOVES.COM, OR WRITE:

Hearthstone Quality Home Heating Products, Inc.

317 Stafford Ave.
Morrisville, Vermont 05661-8695
E-Mail: inquiry@Hearthstonestoves.com

BOLTING YOUR LUNO GAS STOVE TO A PERMANENT STRUCTURE

When installing the Luno in a mobile home it is required that you attach it to the structure. To do this, we have provided a rear attachment kit with the unit. Locate the 2 steel plates and remove them from the packaging. Attach the first (inner) plate to the stove by inserting the angled end into either the upper (shown) or lower slot (invert inner plate) located in the rear of the stove housing. (See figures 13 & 14) Attach the second (outer) steel plate to the first one using the 2 allen screws provided (See Figures 13 & 14). The rear or outer plate can be installed with the flange up or down as desired. We recommend securing the kit directly to suitable wall framing – not drywall sheeting.



Figure 13 – Structure Attachment Kit (top view)



Figure 14 – Structure Attachment Kit (side view)

Leave the screws loose. Next, level, then slide the rear or outer plate up tight to the wall. Using the three screws provided, screw the steel plate to the wall framing. Once the screws are in place and the stove is in its proper location, use the provided allen wrench to tighten the two screws that hold the two plates together.

HIGH ALTITUDE INSTALLATIONS

For installations from 610-1370 meters altitude (2000-4500ft) the orifice sizes (DMS) should be 38 for NG and 53 for LP. See the rating label for more information. For high altitude installations, consult the local gas distributor or the authority having jurisdiction for proper rating methods. If the installer must convert the unit to adjust for varying altitudes, the information sticker (similar to Figure 15) must

be filled out by the installer and adhered to the appliance at the time of conversion. (*Cet appareil est équipé pour des altitudes comprises entre 0 et 2000pieds (0-610m) seulement*).

This appliance is factory set for use between 0-2000 ft. A conversion kit for the Hase Bari (8180) Luno (8160) Modena (8140) is available through HearthStone and shall be used to convert this appliance to the appropriate altitude. Instructions are included with the kit. Ask for Kit #91-56803 for altitude 2000-4500 ft. The conversion should be carried out in accordance with the requirements of the Authority Having Jurisdiction. The normal input rating

| | NG | LP |
|-----------------------------|--------|--------|
| Input rating (0-2000 ft) | 26,500 | 26,500 |
| Input rating (2000-4500 ft) | 26,500 | 26,000 |

This appliance has been converted for use at an altitude of _____ Orifice _____
 Manifold pressure _____
 Input (btu/hr) _____ Fuel Type _____
 Day _____ Month _____ Year _____
 With kit number _____
 Conversion performed by:
 Name: _____
 Company: _____
 Address: _____

Figure 15 - Altitude Conversion Sticker

TROUBLESHOOTING

| Symptom | Possible Cause | Corrective Action |
|---|--|---|
| 1. Pilot will not light. | <p>A. Insufficient gas pressure, air in the pilot line, or dirty or kinked gas line.</p> <p>B. Pilot orifice plugged.</p> <p>C. Defective or misaligned electrode at pilot.</p> <p>D. Defective igniter.</p> <p>E. After sitting for "off" season (summer), pilot assembly may be dirty.</p> | <p>A. Using the piezo sparker, try to light the pilot. If it will not light, check the inlet gas pressure.</p> <p>B. Clean or replace the pilot assembly.</p> <p>C. If a match lights a pilot, check the electrode gap and location. Should be a 1/8" gap in the flame area.</p> <p>D. Check for a good connection between igniter and electrode. Check wire insulation. If properly connected and no spark, replace igniter.</p> <p>E. Clean or replace the pilot assembly.</p> |
| 2. Pilot will not stay lit after carefully following lighting instructions. | <p>A. Low or too high gas pressure</p> <p>B. Faulty connections.</p> <p>C. Defective thermocouple.</p> <p>D. Pilot dirty or plugged.</p> | <p>A. Check for proper inlet pressure for the gas being used.</p> <p>B. Measure voltage between valve body and solder connection on the rear of the valve (where the blue wire connects). It should be no less than 7 mV.</p> <p>C1. Ensure that the thermocouple connection at the gas valve is tight.</p> <p>C2. Check thermocouple output using milli-volt meter. Disconnect from valve and read voltage across wire ends. If the reading is less than 15 mV, replace the pilot assembly.</p> <p>C3. If burning NG, check pilot flame to see that it is impinging on the top of the thermocouple. Clean or replace pilot for maximum flame impingement.</p> <p>D. Clean or replace the pilot assembly.</p> |

Troubleshooting

| Symptom | Possible Cause | Corrective Action |
|--|--|--|
| 3. Pilot burning, no gas to main burner, valve knob in the "ON" position, thermostat and/or on/off/t'stat switch in the "ON" position. | <p>A. Thermostat switch or wires defective.</p> <p>B. Thermopile may not be generating sufficient voltage.</p> <p>C. Plugged burner orifice.</p> | <p>A. Check thermostat/wiring for proper connections. Place jumper wire across terminals at thermostat. If burner comes on, replace defective thermostat. If not OK, place jumper across thermostat wires at gas valve. If burner comes on, tighten connections, or replace faulty wires.</p> <p>B. Check thermopile output, using a milli-volt meter. Take the readings across generator terminals of the gas valve. (TPTH and TP). Milli-volt reading should be greater than 325 mV. If not, replace the pilot assembly. If the meter reading is OK, but the burner does not come on, replace the gas valve.</p> <p>C. Remove and check burner orifice - clean or replace. Note: do not use any metal cleaning device, as this may damage the orifice.</p> |
| 4. Pilot and burner come on, but go out after some warm-up. | <p>A. Inconsistent or insufficient flame on thermopile.</p> <p>B. Insufficient gas pressure.</p> <p>C. Excessive draft.</p> | <p>A. Adjust pilot flame size and assure that the flame is aimed directly at the thermopile.</p> <p>B. Check line pressure to ensure that the correct inlet pressure is present for the type of gas being used. If propane pressure is inconsistent, check for water condensation at the regulator.</p> <p>C. Check Restriction settings per this manual.</p> |
| 5. Frequent pilot outage problem. | <p>A. Pilot flame may be too low or blowing, (high), causing the pilot safety to drop out.</p> <p>B. Excessive draft</p> | <p>A. Clean and/or adjust the pilot flame for maximum impingement on the thermopile and thermocouple.</p> <p>B. Check Restriction settings per this manual.</p> |
| 6. Glass fogs (condensation) | A. A normal result of gas combustion. | A. After the heater warms up, the glass should clear. |
| 7. Blue Flames | A. A normal result during the first 20 minutes. | <p>A. Flames should begin to turn more yellowish after about 20 minutes of burning.</p> <p>B. If the blue color persists; adjust the air shutter for a proper burn.</p> |

Troubleshooting

| Symptom | Possible Cause | Corrective Action |
|--|---|---|
| <p>8. Floating flames, lazy ill-defined, quiet flames, which roll around, sometimes completely off the port, sometimes with overly, yellow tips. Possible sooting. Usually accompanied by the odor of aldehydes.</p> | <p>A. Potentially dangerous incomplete combustion due to incorrect air to fuel ratio (lack of combustion air or excessive fuel delivery i.e. excessive gas pressure, overrating of appliance).</p> <p>B. Incorrect air intake/exhaust flow system. Causes may be:</p> <p>B1. Blocked burner. B2. Blocked primary air B3. Blocked secondary air inlets</p> | <p>A. Check the appliance input rate and reduce if necessary. The air intake/exhaust flow system may be too restrictive or blocked (the rate at which the exhaust leaves [draft] determines the rate at which the combustion air is delivered). Poor draft results in insufficient air delivery or a restricted exhaust. Correct air intake/exhaust flow system.</p> <p>B1. Clear ports. B2. Clear obstructions. B3. Clear obstructions.</p> <p>C. If gas pressures are correct and the flames stay the same, adjust the air shutter for a proper burn.</p> |
| <p>9. Burner flashback. Air-gas mixture ignites inside the burner near the orifice, usually creating a roaring noise like a blowtorch. The problem is an imbalance of gas flow velocity and burning speed pattern.</p> | <p>A. Excessive primary air. B. Burner input underrated. C. Valve leak if flashback occurs with burner valve in off position. D. Improper gas pipe size.</p> | <p>A. Adjust the air shutter for a proper burn.</p> <p>B. Check input rate. Check input pressure using a manometer. Confirm correct gas pressure at house meter or tank (call gas company). Confirm burner orifice size.</p> <p>C. Replace valve. If above corrections do not eliminate flashback, replace burner.</p> <p>D. Correct plumbing.</p> |
| <p>10. Delayed ignition (makes a sudden "whoosh" noise as the burner lights). This is a buildup of gas prior to ignition. This is more prevalent with propane (LP) fuel.</p> | <p>A. Incorrect air-to-fuel ratio. A1. Primary air incorrect. A2. Burner ports plugged. B. Improper log placement.</p> | <p>A1. Adjust the air shutter for a proper burn. A2. Open ports to allow for proper travel of flames. B. Reposition logs to eliminate interference with flame travel.</p> |

RATING LABEL

MODEL # 8160-

SERIAL #

MODEL NAME: LUNO DIRECT VENT GAS FIRED HEATER
LISTED: GAS FIRED DIRECT VENT HEATER

TESTED TO: ANSI Z21.88b-2005/CSA 2.33b-2005
CGA-2.17-M91

REPORT NO. 308211S-T4



CERTIFIED FOR AND US CANADA
HOMOLOGUE POUR LE CANADA
ALSO FOR MOBILE HOME INSTALLATION

CAUTION: DO NOT OPERATE WITH GLASS REMOVED, CRACKED, OR BROKEN.
Replacement on the panel should be done by a licensed or qualified service person.
CAUTIONNER: N'opère l'appareil avec le verre enlevé, craqué ou cassé. Le remplacement du panneau devrait être fait par une personne de service qualifié ou autorisé.

This appliance must be installed in accordance with the local codes, if any, if not, follow the National Fuel Gas Code, ANSI Z223.1 or Canadian Installation Codes, CSA B149.1. (Installer l'appareil selon les codes ou règlements locaux, ou, en l'absence de tels règlements, selon les Codes d'installation CSA-B149.1)

| | ■ NG | ■ LP |
|---------------------------------------|----------|-----------|
| INPUT RATING (Btu/hr) 0-2000 ft | 26,500 | 26,500 |
| INPUT RATING (Btu/hr) 2000-4000FT | 26,500 | 26,000 |
| ORIFICE SIZE (DMS) 0-2000 ft | 38 | 52 |
| MANIFOLD PRESSURE - LO (in. w.c./kpa) | 1.2/0.3 | 3.3/0.8 |
| MANIFOLD PRESSURE - HI (in. W.c./kpa) | 3.5/0.87 | 10.0/2.48 |
| MINIMUM INLET PRESSURE (in. W.c./kpa) | 5.0/1.24 | 11.0/2.88 |
| MINIMUM INPUT (btu/hr) 0/2000 ft | 16,000 | 15,000 |
| MAXIMUM OUTPUT (btu/hr) 0-2000 ft | 20,400 | 20,200 |

WARNING: Improper installation, adjustment, alteration, service or maintenance can cause injury or property damage. Refer to the owner's information manual provided with this appliance. For assistance or additional information consult a qualified installer, service agency or the gas supplier. (L'AVERTISSEMENT: L'installation inconvenante, ajustement, modification, service ou entretien peut causer le dommages de propriété ou blessure. Rétérer au manuel d'information de propriétaire fourni cet appareil. Pour l'assistance ou information supplémentaire consulte un qualifiée installateur, agence de service ou le fournisseur de gaz.)

MINIMUM CLEARANCES TO COMBUSTIBLES

| | |
|--------------------|--------------|
| UNIT TO REAR WALL | 1" / 25 mm |
| UNIT TO SIDE WALLS | 10" / 254 mm |
| CORNER | 7" / 178 mm |

This appliance is only for use with the type of gas indicated on this rating plate and may be installed in an aftermarket, permanently located, manufactured (mobile) home where not prohibited by local codes. See owner's manual for details. This appliance is not convertible for use with other gases, unless a certified kit is used. If the vent air intake system is disassembled for any reason, reinstall per the instructions provided with the initial instructions. This vented gas fireplace heater is not for use with air filters. This appliance must be properly connected to a venting system in accordance with the manufacturer's installation instructions.

VENTED GAS FIREPLACE HEATER - NOT FOR USE WITH SOLID FUEL.



MANUFACTURED BY: HearthStone, MORRISVILLE, VERMONT 05661

| Date of Manufacture | | | | | | | | | | | | | | |
|---------------------|------|------|-----|-----|-----|-----|-----|-----|-----|-----|-----|-----|-----|-----|
| 2007 | 2008 | 2009 | Jan | Feb | Mar | Apr | May | Jun | Jul | Aug | Sep | Oct | Nov | Dec |
| ■ | ■ | ■ | ■ | ■ | ■ | ■ | ■ | ■ | ■ | ■ | ■ | ■ | ■ | ■ |

DO NOT REMOVE OR COVER THIS LABEL

MADE IN USA

3300-584

HEARTHSTONE EURO COLLECTION HASE GAS-FIRED STOVE WARRANTY

These warranties give you specific legal rights. You may also have other rights that vary from State to State.

Hearthstone Quality Home Heating Products, Inc. (Hearthstone) warrants **to the original purchaser only** (the "Original Purchaser") the new gas-fired stove/insert manufactured by Hearthstone and purchased by the Original Purchaser (referred to as the "Stove" for simplicity) against any of the occurrences listed in this document that result from defects in material or workmanship. All obligations of Hearthstone under this document commence on the date the Original Purchaser purchases the Stove (the "Purchase Date").

2-year limited warranty

Hearthstone warrants the following parts of the Stove against the following occurrences that result from defects in material or workmanship:

- 🔥 Ceramic glass against cracking due to thermal shock.
- 🔥 Vermiculite panels that break due to thermal stress and fall into the firebox.

This warranty expires on the second (2nd) anniversary of the purchase date.

3-year limited warranty

Hearthstone warrants the following parts of the Stove against the following occurrences that result from defects in material and workmanship:

- 🔥 Gas train, including gas valve, millivolt wiring, spill switch, pilot assembly, thermopile, thermocouple, piezo igniter – against breakage or malfunction.

This warranty expires on the third (3rd) anniversary of the Purchase Date.

5-year limited warranty

Hearthstone warrants the following parts of the Stove against the following occurrences that result from defects in material or workmanship:

- 🔥 All steel parts against cracking or burn-through
- 🔥 All cast parts against breakage.
- 🔥 Burners, air shutters and orifices – against breakage, cracking or burn-through.
- 🔥 TEK logs and embers – against breakage, cracking or burn-through.

This warranty expires on the fifth (5th) anniversary of the purchase date.

These warranties do not cover the following:

- 🔥 Damage caused during shipment.
- 🔥 Damage resulting from incorrect installation or operation (non-observance of the operating instructions).
- 🔥 Damage or poor function resulting from faulty and/or incomplete setup and installation and from faulty start-up or misuse of the Stove, including but not limited to using the incorrect fuel for the Stove.
- 🔥 Damage resulting from installation, modification, alteration, repair or service.
- 🔥 Damage due to water or to installation of the Stove in damp rooms or in damp environments, including high ambient humidity.
- 🔥 Damage due to installation of the Stove in an atmosphere contaminated by chemicals, including but not limited to chlorine, fluorine compounds or salts.

- 🔥 Scratches and damage on glass, steel surfaces/steel components and vermiculate panels due to mechanical wear.
- 🔥 Standard wear and tear of the stressed components resulting from normal usage of the Stove.
- 🔥 Damage, operational-related problems or inadequate performance caused by poor fuel quality, site, installation or environmental influences, including but not limited to nearby trees, roof tops, buildings, wind, hills, mountains, inadequate or excessive venting, insufficient make-up air or negative air pressure whether or not caused by exhaust fans, clothes dryers etc.

Additional exclusion of any liability is for the following:

- 🔥 Grit leaking during transportation and installation of the Stove.
- 🔥 Occurrence of odors during the first hours of operation resulting from the process-related "baking" of the stove paint and surrounding environment.
- 🔥 Occurrence of noises (click and pop sounds) due to expansion/contraction during the heating-up and cooling-down phases.

THE WARRANTIES CONTAINED IN THIS DOCUMENT ARE EXCLUSIVE AND ARE GIVEN BY HEARTHSTONE AND ACCEPTED BY THE ORIGINAL PURCHASER IN LIEU OF ALL OTHER EXPRESS WARRANTIES AND ANY OBLIGATIONS, LIABILITIES, RIGHTS, CLAIMS, OR REMEDIES IN CONTRACT OR TORT, WHETHER OR NOT ARISING FROM HEARTHSTONE'S NEGLIGENCE, ACTUAL OR IMPUTED. ALL IMPLIED WARRANTIES, INCLUDING THE WARRANTIES OF MERCHANTABILITY AND FITNESS FOR A PARTICULAR PURPOSE, ARE GIVEN **ONLY** TO THE EXTENT REQUIRED BY FEDERAL OR STATE LAW. EXCEPT AS OTHERWISE REQUIRED BY STATE LAW, UPON THE EXPIRATION OF THE EXPRESS LIMITED WARRANTIES CONTAINED HEREIN, **NO** IMPLIED WARRANTIES, INCLUDING THE IMPLIED WARRANTIES OF MERCHANTABILITY OR FITNESS FOR A PARTICULAR PURPOSE, SHALL APPLY TO THE SUBJECT STOVE. **SOME STATES DO NOT ALLOW LIMITATIONS ON HOW LONG AN IMPLIED WARRANTY LASTS, SO THE ABOVE LIMITATION MAY NOT APPLY TO YOU.**

THE WARRANTIES CONTAINED IN THIS DOCUMENT EXTEND **ONLY** TO THE ORIGINAL PURCHASER OF THE STOVE WARRANTED HEREUNDER. THEY DO NOT EXTEND TO ANY SUBSEQUENT OWNERS.

UNDER NO CIRCUMSTANCES SHALL HEARTHSTONE BE LIABLE TO THE ORIGINAL PURCHASER OR ANY OTHER PERSON FOR ANY INCIDENTAL OR CONSEQUENTIAL DAMAGES, INCLUDING BUT NOT LIMITED TO DAMAGE TO PROPERTY OR PERSONAL INJURIES, WHETHER ARISING OUT OF BREACH OF WARRANTY, TORT, OR OTHERWISE, EVEN IF HEARTHSTONE HAS BEEN APPRAISED OF THE POSSIBILITY OF SUCH DAMAGES. **SOME STATES DO NOT ALLOW THE EXCLUSION OR LIMITATION OF INCIDENTAL OR CONSEQUENTIAL DAMAGES, SO THE ABOVE LIMITATION OR EXCLUSION MAY NOT APPLY TO YOU.**

Qualifying for warranty coverage

To obtain performance of any obligation under this document, the Original Purchaser must, **within the applicable warranty time period**, contact their dealer, or Hearthstone at the address below, for instructions regarding the return of defective parts for repair, the return of the Stove for repair, or a Dealer service call. The Original Purchaser should refer to the Dealer network search engine contained on Hearthstone's Web site (www.Hearthstonestoves.com) to find a Hearthstone Dealer nearest the Original Purchaser's current location.

Hearthstone Quality Home Heating Products, Inc.

317 Stafford Ave.
 Morrisville, Vermont 05661-8695
 E-Mail: inquiry@Hearthstonestoves.com
www.hearthstonestoves.com

NOTES: