

# hase<sup>®</sup> - Bari

(Model 8170)

## Wood Stove OWNER'S MANUAL

### INSTALLATION AND OPERATING INSTRUCTIONS



We recommend that our products be installed and serviced by professionals who are certified in the U.S. by NFI (National Fireplace Institute).

[www.nficertified.org](http://www.nficertified.org)

Warnock Hersey



**SAVE THIS OWNER'S MANUAL  
FOR FUTURE REFERENCE**

**PLEASE READ THIS ENTIRE OWNER'S MANUAL BEFORE YOU  
INSTALL AND USE YOUR NEW BARI WOOD STOVE.**

**To reduce the risk of fire, follow the installation instructions.  
Failure to follow these instructions can result in property damage,  
bodily injury, or even death.**

**CONTACT LOCAL AUTHORITIES WITH JURISDICTION (BUILDING DEPARTMENT or  
FIRE OFFICIALS), ABOUT PERMITS REQUIRED, RESTRICTIONS AND INSTALLATION  
INSPECTION IN YOUR AREA.**

# TABLE OF CONTENTS

<b>INTRODUCING YOUR BARI WOOD STOVE.....</b>	<b>3</b>
CODES.....	4
SAFETY INFORMATION.....	4
Periodic Checklist.....	5
Emergency Procedures.....	5
SPECIFICATIONS.....	5
<b>SETTING UP YOUR BARI WOOD STOVE.....</b>	<b>6</b>
UNPACKING.....	6
INSTALLING YOUR STOVE.....	6
HEARTH REQUIREMENTS AND FLOOR PROTECTION.....	6
ROTATION LOCK INSTALL PROCEDURE.....	7
Combustible Surface Required Clearances:.....	8
OUTSIDE AIR SUPPLY.....	10
VENTING COMPONENTS AND CONFIGURATION REQUIREMENTS.....	10
CONNECTING THE STOVE TO A CHIMNEY.....	11
INSTALLING IN A MOBILE HOME.....	14
<b>OPERATING YOUR BARI WOOD STOVE.....</b>	<b>15</b>
CONTROLS AND FEATURES.....	15
CHOOSING FIREWOOD.....	16
BUILDING A FIRE.....	16
NORMAL OPERATION.....	17
Building A Fire For Everyday Use.....	17
Burn Rate.....	17
Over-Fire Caution.....	17
Removal And Disposal Of Ashes.....	17
MAINTENANCE.....	18
Creosote Formation And Need For Removal.....	18
Door Removal Procedure:.....	18
Gaskets.....	18
Door Gasket Replacement Procedures:.....	18
Latch Adjustment Procedures:.....	19
Glass.....	19
Glass replacement procedures:.....	20
Vermiculite Panel Replacement:.....	20
Stone.....	20
<b>TROUBLESHOOTING.....</b>	<b>21</b>
TROUBLESHOOTING GUIDE.....	22
REPLACEMENT PARTS & OPTIONAL ACCESSORIES.....	23
<b>SAFETY LABEL.....</b>	<b>24</b>
<b>LIMITED WARRANTIES.....</b>	<b>25</b>

# Introducing Your Bari Wood Stove

Thank you for purchasing a HASE Collection Bari woodstove from Hearthstone Quality Home Heating Products. This stove will provide years of comfortable heat. This stove also provides the benefits of advanced technology in wood burning without the cost and maintenance requirements of a catalytic device. The Bari blends modern technology with the unique beauty and qualities of steel and soapstone. We trust that you will appreciate the quality of this handcrafted product.

Your Bari woodstove is designed to burn efficiently, and produce a large amount of heat. However, you should not consider your Bari the primary heat source for your home. The Bari's unique ability to rotate 180 degrees, and the very large curved glass window allow you to enjoy the fire from a variety of locations in the room.

Please read this manual in its entirety. Its purpose is to familiarize you with your stove's safe installation, proper break-in, operation and maintenance. It contains extremely important information so keep it handy and refer to it often.

A qualified heating technician may need this owner's manual as a reference when installing this stove in your home. There are national, state, and local building codes that direct the technician on how to install your stove. These codes stipulate the dimension of stovepipe and clearances to walls, ceilings, hearth, and other combustible surfaces. The codes exist to reduce the risk of fire. Failure to follow these instructions can result in fire, property damage, bodily injury, and even death.

Install the stove in a safe, open area, away from traffic flow, doors, and hallways. If possible, try to install the stove near an existing chimney and chimney connector. It is extremely important to install this stove with the proper clearance from combustible surfaces. You can purchase specific connector pipe and special wall coverings as specified by this manual and the NFPA 211 code to protect combustible surfaces. Keep furniture, drapes, curtains, wood, paper, and other combustibles at least 36 inches (92 cm) away from the stove. Never install the stove in a location where gasoline, kerosene, charcoal lighter fluid or other flammable liquids are used or stored.

Install the stove in your living area to allow heat to radiate naturally to distant rooms. Do not install your stove in a poorly insulated area. This is inefficient and would likely result in higher fuel usage and possibly unsafe burning conditions.

 **SAFETY NOTICE:**  
**AN IMPROPERLY INSTALLED STOVE CAN RESULT IN A HOUSE FIRE. FOR YOUR SAFETY, CAREFULLY FOLLOW THE INSTALLATION DIRECTIONS. CONTACT LOCAL BUILDING OR FIRE OFFICIALS ABOUT RESTRICTIONS AND INSTALLATION INSPECTION IN YOUR AREA.**

The safety of your stove will depend on many factors, some of which include: distance to combustible objects, correct venting, and adequate chimney maintenance. Should you have any questions, do not hesitate to contact your dealer for additional information.

Contact your dealer for any necessary warranty service.

This stove is warranted by:

**HearthStone *Quality Home Heating Products, Inc***®  
317 Stafford Ave.  
Morrisville, Vermont 05661

## CODES

When you install your Bari wood stove, it is imperative that you adhere to all Federal and local codes. Obtain these codes from either of the following sources:

American National Standards Institute, Inc. (ANSI)  
1430 Broadway  
New York, NY 10018

National Fire Protection Association, Inc. (NFPA)  
Battery March Park  
Quincy, MA 02269

If you are installing your Bari in a mobile or manufactured home, follow the guidelines described in the Manufactured Home Construction and Safety Standard, Title 24 CFR, Part 3280 (United States).

## SAFETY INFORMATION

**Read and understand this Owner's Manual thoroughly before installing and using this stove.**

### Make sure to install your stove

- ❑ According to the manufacturer's recommendations,
- ❑ In accordance with all applicable codes, and
- ❑ With the proper sized chimney.

### When using your stove:

- ❑ Warn children and others of the danger of touching hot, radiating surfaces of your woodstove. For your additional safety, you can purchase hearth and stove guards through your local dealer.
- ❑ Burn natural wood only. Higher efficiencies and lower emissions result when burning air-dried, seasoned wood, as compared to green or freshly cut wood.
- ❑ Use caution when loading firewood into a hot stove.
- ❑ Keep the front door closed and secured at all times except when loading wood.
- ❑ Keep the ash pan tray fully inserted and the handle tightly latched.
- ❑ Inspect the stovepipe, chimney connector and chimney, as recommended.

### Follow these safety precautions:

- ❑ **Never** modify this stove in any way.
- ❑ **Never** burn kiln dried, painted or treated wood in this stove.

- ❑ **Never** burn garbage or trash, colored or glossy paper, solvents, plywood, artificial logs, cardboard, or driftwood, in this stove.
- ❑ **Never** burn coal in this stove.
- ❑ **Never** use gasoline, kerosene, charcoal lighter fluid, or other flammable fluids to start or invigorate the fire. These fuels will cause dangerous burning conditions in the stove. Keep all such materials away from the stove.
- ❑ **Never** use the stove if the ash pan is open, damaged, not present, or does not fully seal. The ash pan cover must be present under the pan to ensure the pan seals properly.
- ❑ **Never** use a wood grate or other device to elevate the fire.
- ❑ **Never** allow logs in the firebox to contact with the glass when the door is closed.
- ❑ **Never** slam the door or use the door to force wood in to the stove.
- ❑ **Never** over-fire your stove. (See page 17)
- ❑ **Never** put articles of clothing or candles on a hot stove.
- ❑ **Never** connect the stove to a flue used by another appliance.

### Other safety guidelines

- ❑ Keep all combustible items such as furniture, drapes, clothing, and other items, at least 36" (0.92 m) from the stove (See page 8)
- ❑ Install a smoke detector, preferably in an area away from your wood stove.
- ❑ Keep a fire extinguisher handy. We recommend the type rated "A B C."
- ❑ Dispose of ashes properly. (See page 17)
- ❑ Keep children and pets away from the stove when it is burning; they could be seriously injured by touching a hot stove.
- ❑ Clean your chimney system as needed. (See page 18)

## PERIODIC CHECKLIST

Perform each of these tasks at the specified intervals.

### At the End of Every Week:

- Empty ashes from the firebox and ash pan, sooner if the firebox or the ash pan are full.

### At the Beginning of Every Other Month:

- Depending upon your use of the stove, visually inspect the chimney connector and chimney for creosote. (Please see page 18)
- Check door seals using the "dollar bill test." - When the stove is cool, shut the door on a dollar bill. If the bill pulls out without any resistance, then your stove's door is not sealing properly. To tighten the seal, adjust the door latch mechanism or change the door gasket. (Refer to page 18.)

### At the End of Every Season:

- Dismantle the chimney connector and clean it thoroughly. Replace any pieces that show signs of rust or deterioration.
- Inspect and, if necessary, clean your chimney.
- Thoroughly clean out the inside of the stove.
- Inspect all door gasket material and replace if worn, frayed, cracked or extremely hard.
- Inspect and replace cracked or damaged vermiculite panels.

## EMERGENCY PROCEDURES

If you have a stovepipe or chimney fire, follow these instructions:

1. If the fire is too threatening, leave the area and call the fire department immediately! If not, perform the next three steps.
2. Close the primary air control.
3. Close the stovepipe damper (if present).
4. Keep the stove front door and ash pan closed!



### WARNING

**DO NOT ATTEMPT TO PUT OUT A STOVEPIPE OR CHIMNEY FIRE BY THROWING WATER ONTO THE STOVE, STOVEPIPE, OR CHIMNEY. THE EXTREMELY HIGH TEMPERATURE OF SUCH FIRES CAN CAUSE INSTANTANEOUS STEAM AND SERIOUS BODILY HARM.**

Once the chimney fire expires, leave the primary air control closed and let the fire in the stove die out completely. Inspect the stove, stovepipe, and chimney thoroughly for any sign of damage before firing the stove again. You must correct any damage before using your stove again.

## SPECIFICATIONS

### Maximum Heat Output

35,000 per hour of cordwood (based on independent laboratory test results).

### Floor Size of Heated Area

Up to a maximum of 1,200 square feet. Factors unique to your home can reduce the square footage the stove will heat. Home insulation value, number and efficiency of windows, floor plan, stove placement, quality of the fuel and other conditions may limit the heating ability of the stove.

### Firebox Capacity

1.25 cubic feet or 46 pounds of wood (The amount and weight of wood contained per cubic foot of firebox volume can vary from 15 to 36 lbs. per cubic foot depending on type of wood, moisture content, packing density and other factors. As a constant for comparison and test purposes, we are assuming 20 lbs. of seasoned hardwood per cubic foot of firebox volume).

**Maximum Log Length:** 17" (43 cm), vertically

### Stove Dimensions

**Height:** 41.5" (105 cm)

**Diameter:** 19.5" (49.5cm)

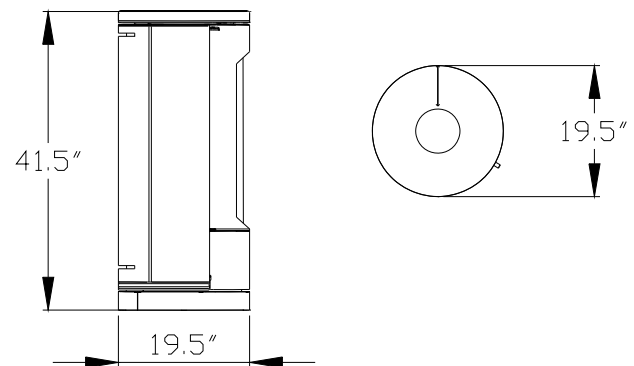

**Stovepipe Size:** 6" (152 mm) diameter

**Metal Chimney:** 6" (152 mm) inside diameter

**Masonry Chimney:** 6" (15.2cm) inside diameter  
(round flue) 8" x 8" (20 x 20cm) (square flue)

**Actual Weight:** 475 (216 kg) pounds

**Crate Dimensions:** H-49.5" W-32.4" L-24.5" or  
126x82.3x62.2cm (add 4" or 10.2cm for pallet).

### Optional Equipment:

Outside Air Kit 91-53700

Mobile Home Lockdown Kit- 91-99400

**Soapstone Finish<sup>1</sup>** Smooth, Gray Soapstone

<sup>1</sup>Gray soapstone is a natural product and colors will vary from stone to stone. Various amounts of gray, charcoal, blue and green are evident dependant on the natural composition of the stone.

# Setting Up Your Bari Wood Stove

## UNPACKING

HearthStone packages your Bari stove with the greatest care so that it ships safely. Under certain circumstances, however, damage may occur during transit and handling. When you receive the Bari, carefully unpack and inspect the stove and all accompanying parts. Make sure that all parts are included in the box. If any parts are damaged or missing, please contact your dealer immediately.

The stone panels on this stove are large and heavy (150 pounds total). Use a second person to assist in handling the panels to avoid injury, or damaging the panels. Despite the mass of each piece of soapstone, they will break if dropped.

## INSTALLING YOUR STOVE

Choose a place to install your Bari woodstove. Inspect this location to make sure that the stove and stovepipes will have the required clearance from combustible materials that are near the stove. Combustibles include walls, floor, ceiling, and chimney chase. You must carefully consider the clearances to all of these combustibles before actually connecting your stove.

If the floor is made of combustible material, then a non-combustible floor protector is required between the floor and the stove. *An example of a non-combustible floor protector is a hearth constructed with a continuous layer of a listed backer board (such as Micore, Wonder-Board or Durock) used for ember protection with a tile, brick, slate, or another non-combustible facing.*

If you use a close clearance connector pipe, ensure it is listed with Underwriter's Laboratories. Check the listing of your pipe with UL for the correct clearances.

The diagrams in this manual represent typical installations, but are specific to the Simpson Dura-Vent DVL brand.

## Clearances to NFPA Code 211 Protected Surfaces

You can reduce the clearances to combustible surfaces by using any National Fire Protection Agency (NFPA) approved wall protection system. Please refer to NFPA Code 211 for specifications and complete details. You can obtain this information directly from the NFPA.

**National Fire Protection Agency**  
 Batterymarch Park  
 Quincy, MA 02269  
 1-800-344-3555  
 1-617-770-3000

## HEARTH REQUIREMENTS AND FLOOR PROTECTION

Ensure combustible flooring is protected with a covering of noncombustible material. The floor protection must extend beyond the **body** of the stove at the minimum as follows:

In Figures 1 and 2 you will find two hearth options; one hearth for the freely rotating stove and the other for the locked stove.

- \* Installations in Canada require 18" (45.72 cm) of floor protection on both side and front.
- \*\* Rear clearance required only if stovepipe runs horizontally back above the top of the stove.

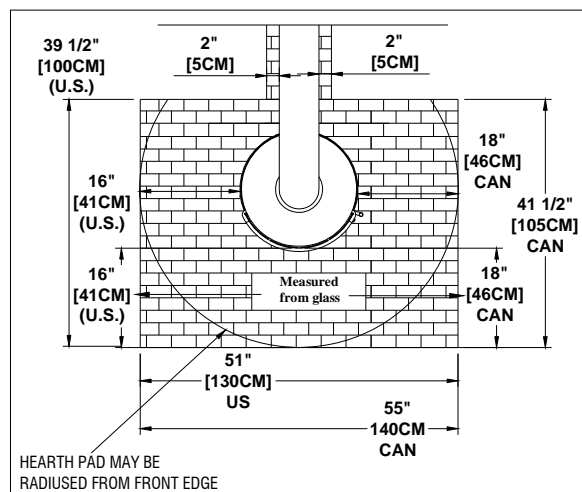

**FLOOR PROTECTOR  
 STOVE CAN ROTATE  
 180 DEG.**

**Figure 1**

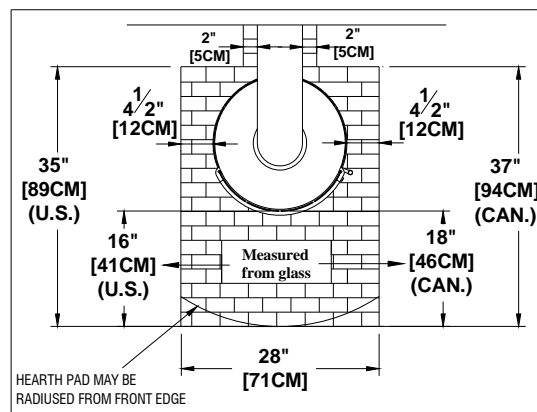

**Floor protection for stoves only  
 in the locked position shown**

**Figure 2**

*Note: Dimensions shown in previous figures are from the body of the stove.*

The Bari wood stove has a unique feature that allows it to rotate. This rotation allows the body of the stove to spin a full 90 degrees to either side. In order to install the Bari onto the smaller hearth protector shown in Figure 2, you must lock the stove in place. To do this, follow the instructions below:

#### ROTATION LOCK INSTALL PROCEDURE

1. Open the lower control door and locate the rotation control.
2. Ensure the stove is in its 0-degree orientation (line up the index marks)(see fig. 3), and then position the stove to center the door on the hearth.
3. Lift the control lever and remove the hex head screw (see fig. 4).
4. Rotate the control clockwise until the tangs release, and then lift the control out of its position (see fig. 5).
5. Insert the rotation lock, and line up the mounting screw holes (fig. 6).
6. Insert the screw and tighten securely with the hex wrench (fig. 7).



**Figure 3 - Zero Index Marks**



**Figure 4 - Remove Mounting Screw**

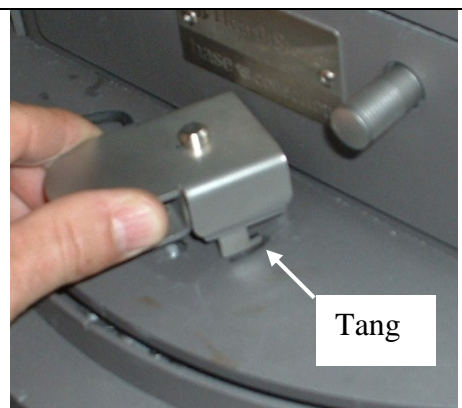

**Figure 5 - Remove Control**



**Figure 6 - Insert Rotation Lock**



**Figure 7 - Tighten Mounting Screw**

**COMBUSTIBLE SURFACE REQUIRED CLEARANCES:**

It is very important to follow minimum clearances for chimney connectors to combustibles such as walls and ceilings when installing the stove near combustible surfaces.

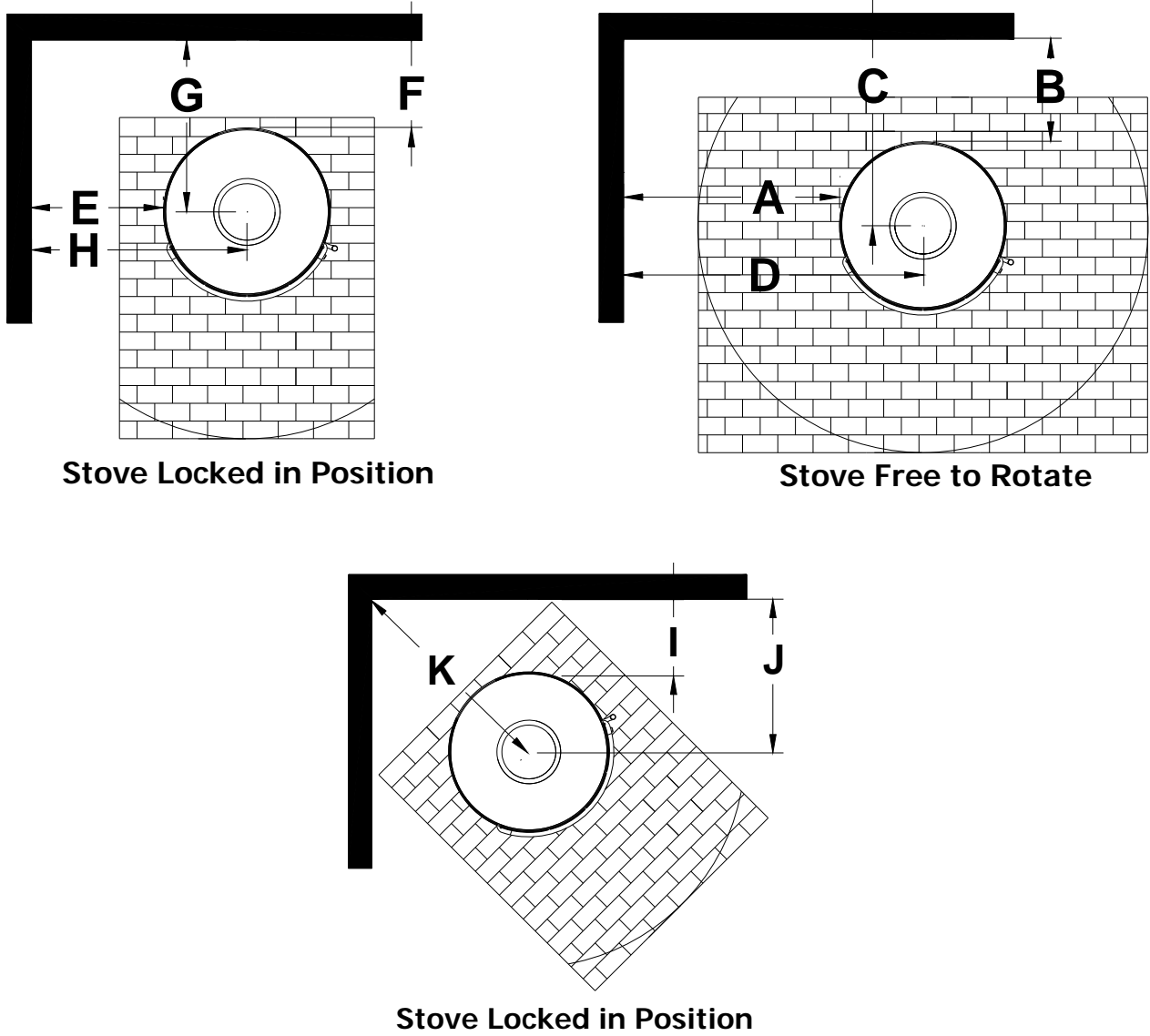

**Figure 8 Clearance to combustibles**

Clearances		Parallel								Corner		
		A	B	C	D	E	F	G	H	I	J	K
Single or double wall	Inches	38	17	26.5	47.5	17	7	16.5	26.5	12	21.5	30.5
	Centimeters	96.5	43	67.5	120.5	43	18	42	67.5	30.5	55	77.5

Alcove Clearances (inches)	Unprotected Surfaces	Protected Surfaces (NFPA-211)
Minimum alcove width	46	See NFPA-211
Maximum alcove depth	48	See NFPA-211
Alcove ceiling from floor	84	See NFPA-211



## Chimney Connector Systems and Clearances from Combustible Walls for Residential Heating Appliances

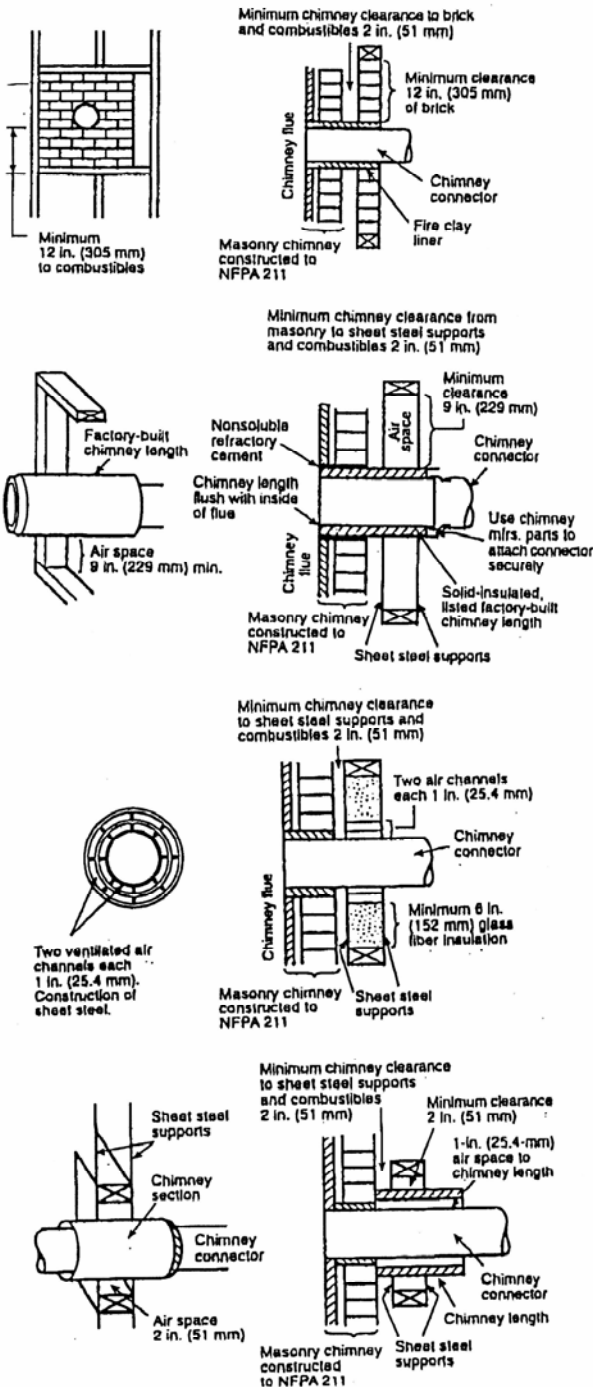

A Minimum 3.5-in thick brick masonry all framed into combustible wall with a minimum of 12-in brick separation from clay liner to combustibles. The fireclay liner shall run from outer surface of brick wall to, but not beyond, the inner surface of chimney flue liner and shall be firmly cemented in place.

B Solid-insulated, listed factory-built chimney length of the same inside diameter as the chimney connector and having 1-in. or more of insulation with a minimum 9-in. air space between the outer wall of the chimney length and combustibles.

C Sheet steel chimney connector, minimum 24 gauge in thickness, with a ventilated thimble, minimum 24 gauge in thickness, having two 1-in. air channels, separated from combustibles by a minimum of 6-in. of glass fiber insulation. Opening shall be covered, and thimble supported with a sheet steel support, minimum 24 gauge in thickness.

D Solid insulated, listed factory-built chimney length with an inside diameter 2-in. larger than the chimney connector and having 1-in. or more of insulation, serving as a pass-through for a single wall sheet steel chimney connector of minimum 24 gauge thickness, with a minimum 2-in. air space between the outer wall of chimney section and combustibles. Minimum length of chimney section shall be 12-in. chimney section spaced 1-in. away from connector using sheet steel support plates on both ends of chimney section. Opening shall be covered, and chimney section supported on both sides with sheet steel supports securely fastened to wall surfaces of minimum 24 gauge thickness. Fasteners used to secure chimney section shall not penetrate chimney flue liner.

## OUTSIDE AIR SUPPLY

(Kit #91- 53700)

You can connect an outside air source directly to this stove using an optional outside air kit. The advantage of providing outside air directly to the stove is that the air used by the stove for combustion is taken from outside the residence rather than from within the room where the stove is located.

The outside air kit for this stove allows for the direct connection of the stove's air intake to a minimum 3" (76 mm) diameter duct (supplied by others) which leads to the outside of the house. When considering placement of the duct from the outside of the house to the hearth, keep in mind the need to avoid structural members of the house. The outside air kit will attach to the back of the stove.

The International Residential Code (IRC) does not allow the outside air duct to terminate higher than the appliance. Some building officials also do not like to see any vertical rise in the duct's termination. HearthStone recommends the termination be at the same level, or lower than the air intake on the stove.

Locate the termination of the duct on the outside wall of the home in such a manner to avoid the possibility of obstruction by snow, leaves or other material. Screen the termination using ¼" x ¼" mesh rodent screen and cover it with a rain/wind proof hood (flex pipe, outside termination, mesh, and hood supplied by others) Contact your dealer for availability).

## VENTING COMPONENTS AND CONFIGURATION REQUIREMENTS

### DO NOT CONNECT THIS UNIT TO A CHIMNEY FLUE USED BY ANOTHER APPLIANCE

- Single wall connector that is 24 MSG or 25 MSG blued steel stovepipe.
- Double wall connector (close clearance pipe) which is used with a listed, factory-built "Type HT" chimney or with a masonry chimney to reduce clearances, is available from several manufacturers, your dealer can help you choose. Some air insulated connector pipe models available are Simpson Dura Vent DVL and Metalbestos DS. Security, GSW and Ameritec also have acceptable close clearance connector pipe.
- When used in a mobile home, a spark arrester is required. (See page 14)
- The chimney connector cannot pass through a floor or ceiling, nor any attic or roof space, closet or similar concealed space. Where venting requires passage through a wall or partition of combustible construction, the installation must conform to NFPA Code 211 or CAN/CSA - B365.

- It is very important to follow minimum clearances for chimney connectors to combustibles such as walls and ceilings when installing the stove. Typical chimney connector clearances are outlined below. The single wall clearances are generic; the double wall clearances shown are for Simpson DuraVent DVL. **CHECK THE SPECIFICATIONS FROM THE MANUFACTURER OF YOUR CONNECTOR.**

## Components of a Venting System

The complete venting system consists of several components: chimney connector, wall thimble, wall pass-through, chimney, and liner. It is *absolutely necessary* that you install all of these components and maintain the clearances to combustibles discussed earlier to ensure a safe stove installation.

To protect against the possibility of a house fire, you *must properly install and constantly maintain the venting system*. Upon inspection, immediately replace rusted, cracked, or broken components.

- The *chimney connector* is the stovepipe from the woodstove to the chimney. The chimney connector stovepipe is 6" (152 mm) diameter, 24 MSG or 25 MSG blued steel connector pipe. *Do not use aluminum or galvanized steel pipe* - they cannot withstand the extreme temperatures of a wood fire.
- The *thimble* is a manufactured (or site-constructed) device installed in combustible walls through which the chimney connector passes to the chimney. It keeps the walls from igniting. You must use a wall thimble when installing a chimney connector through a combustible wall to the chimney.
- A *wall pass-through* (or chimney support package) also keeps the walls from igniting. You must use one when connecting through a wall or ceiling to a prefabricated chimney.
- Only install this stove to a *lined masonry chimney* or an approved high temperature *prefabricated residential* type building heating appliance chimney. *Do not* connect this stove to a chimney serving another appliance; you will compromise the safe operation of both the wood stove and the connected appliance.

### WARNING: DO NOT CONNECT THIS APPLIANCE TO ANY AIR DISTRIBUTION DUCT OR SYSTEM.

- A *liner* is the UL 1777 or ULC S635 (for factory built fireplace or masonry) chimney.

You must connect your stove to a chimney comparable to those recommended in this manual. *Do not use stovepipe as*

a chimney. Use stovepipe for freestanding installations only to connect the stove to a proper chimney.

## Installing a Venting System

Install the rotating flue collar adaptor to the top of the stove. Attach stovepipe sections to the rotating adaptor and to each other with the crimped end toward the stove. If creosote builds up, this allows the creosote to run into the stove and not on the outside of the stovepipe or onto the stove.

Secure all joints, including attaching the stovepipe to the stove's flue collar, with three sheet metal screws. Install #10 x 1/2" (3 mm x 13 mm) sheet metal screws into the holes pre-drilled in the flue collar. Disregarding the screws can cause joints to separate from the vibrations that result from a creosote chimney fire.

You can simplify connecting stovepipe by using additional accessories such as telescoping pipes, slip-connectors or clean-out tees. These accessories ease the periodic inspection of your chimney, as well as allow you to dismantle the stovepipe easily (without moving the stove).

Install the stove as close as practical to the chimney, while maintaining all proper clearances. Install stovepipe that is as short and as straight as possible. Horizontal runs of stovepipe must always rise away from the stove at a minimum of 1/4" per foot (21mm/m).

*We do not recommend long runs of stovepipe to increase heat dispersal.* Longer lengths of stovepipe or more connecting elbows than necessary increase the chances of draft resistance and the accumulation of creosote buildup.

In general, you do not need to install a stovepipe damper with the Bari. Some installations, however, could benefit from a stovepipe damper, such as a tall chimney which can create a higher than normal draft. In such cases, a damper can help regulate the draft. The Bari requires a draft between 0.06" and 0.1" WC. For drafts above 0.1" WC, install a stovepipe damper. Check the draft at stove installation time.

Remember, the NFPA recommends minimum clearances for chimney connectors to combustibles such as walls and ceilings. Once the stove is installed at safe distances from these combustible surfaces, it is important to maintain these connector clearances for the remainder of the installation.

## CONNECTING THE STOVE TO A CHIMNEY

You can install your Bari to a prefabricated metal chimney, or a masonry chimney.

## Connecting to a Prefabricated Metal Chimney

There are two ways to install a prefabricated metal chimney:

- An *interior* installation where the chimney passes inside the residence through the ceiling and roof.
- An *exterior* installation where the chimney passes through the wall behind the stove then up the outside of the residence.

Whenever possible, choose an interior chimney. An interior chimney heats up quickly and retains its heat; thus promotes a better draft and discourages the formation of creosote. An exterior chimney does not benefit from the warmth of the building, so it typically operates at lower flue temperatures than an interior chimney. An exterior chimney's draft is not as strong and may experience increased creosote accumulation.

When connecting the Bari to a prefabricated metal chimney, you must follow, precisely, the manufacturer's installation instructions. Use only Type HT (2100 deg. F), prefabricated metal chimneys listed per UL 103 or ULC S629 standards.

Ensure the size of the chimney's flue is appropriate for the Bari. The Bari requires a 6" (152 mm) inside diameter flue for new installations. A 6" diameter flue provides adequate draft and performance. You can use an 8" (203 mm) diameter existing flue with a reducer. An oversized flue contributes to creosote accumulation. (In this case, bigger is NOT better.)

When purchasing a prefabricated chimney to install with your stove, Ensure you also purchase from the same manufacturer the wall pass-through (or ceiling support package), "T" section package, fire-stops (when needed), insulation shield, roof flashing, chimney cap, and any other needed accessories. Follow the manufacturer's instructions when installing the chimney and accessories. In addition, ensure you maintain all manufacturers' recommendations for the proper clearances to the chimney.

## Connection to a Masonry Chimney

Consider two primary elements when connecting your stove to a masonry chimney: the chimney itself and the thimble where the stovepipe connects to the chimney. Use only Code approved masonry chimneys with a flue liner.

Before connecting to a masonry chimney, hire a professional to examine the chimney for cracks, loose mortar, and other signs of deterioration and blockage. If the chimney needs repair, complete them before installing and using your stove. Do not install your stove until the chimney is safe for use.

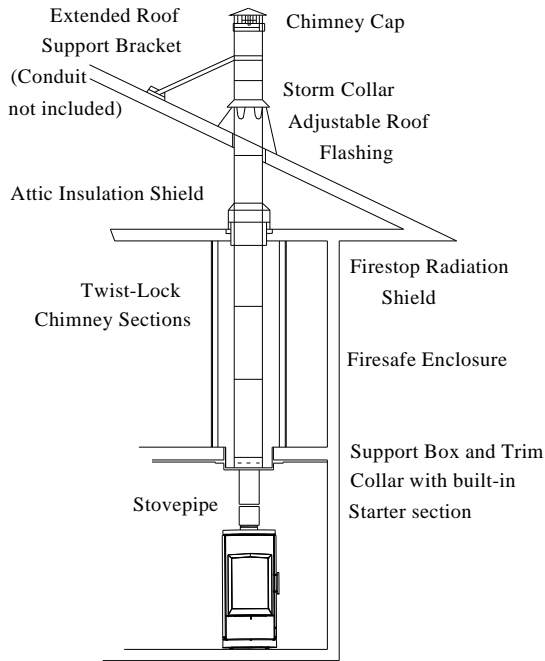

Two story house installation with attic.

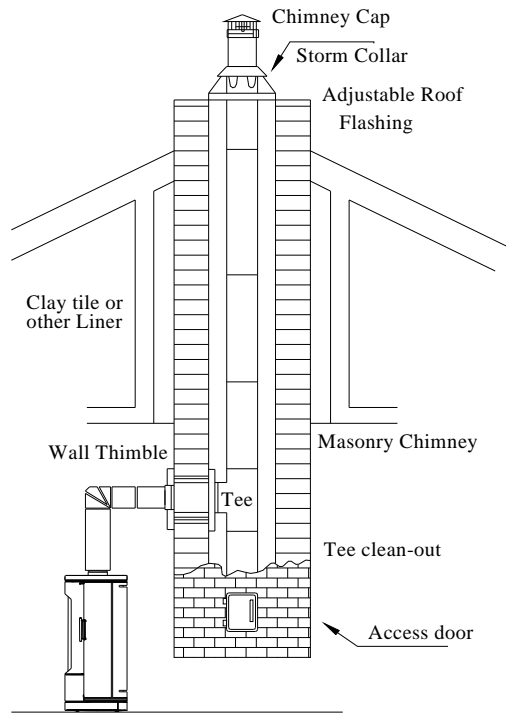

Chimney pipe through Clay tile or other Lined Masonry Chimney

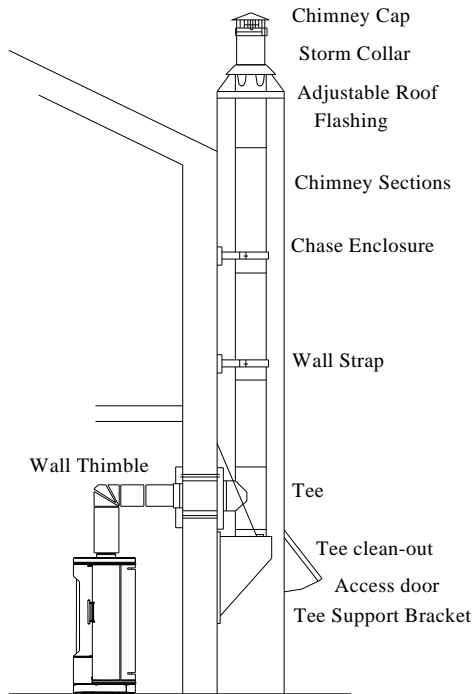

Chimney through outer wall with enclosed chase. Chimney is supported by Tee Support Bracket.

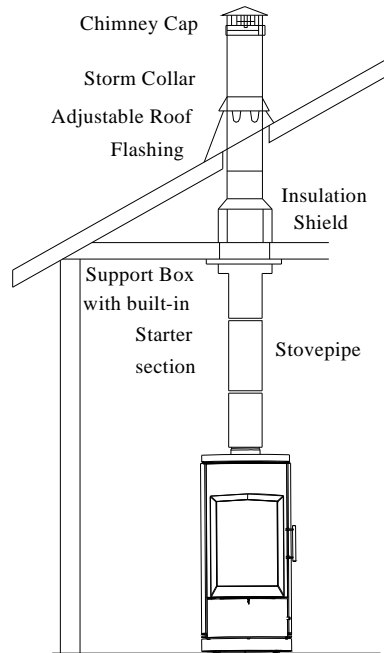

One story house installation with attic. Chimney is supported by Ceiling.

Make sure the chimney's cleanout is complete and working properly. To avoid a loss of draft, the cleanout door must close completely and provide a tight seal. If the cleanout door leaks, the chimney will cool, your stove will perform poorly, and creosote will build up.

Make sure the size of the chimney's flue is appropriate for this stove and that it is not too large. Use a masonry chimney with a maximum 8" x 8" (203 mm x 203 mm) tile size for best results. An oversized flue contributes to the accumulation of creosote.

Use the following checklist to ensure that your masonry chimney meets these minimum requirements:

**Masonry Chimney wall construction:**

- ❑ Mortared brick or modular block at least 4" (102 mm) thick
- ❑ A mortared rubble or stone wall

**Flue liner options:**

- ❑ Tile - minimum wall thickness of 5/8" (16 mm)
- ❑ Tile - installed with refractory mortar
- ❑ Tile - at least 1" (25 mm) air space around liner
- ❑ Stainless steel - UL listed 6" diameter

- ❑ Stainless steel - fill space around liner with vermiculite (keeps liner warmer for better performance)
- ❑ Ensure an equivalent flue liner is a listed chimney liner system meeting type HT requirements or other approved material.

**Interior chimney requirements:**

- ❑ At least 2" (51 mm) clearance to combustibles
- ❑ Fire stops installed at the spaces where the chimney passes through floors and/or ceiling
- ❑ Any insulation is at least 2" (51 mm) from the chimney

**Exterior chimney requirements:**

- ❑ At least 1" (25 mm) clearance to combustibles

**Chimney height requirements (See Illustration below):**

- ❑ At least 3 feet (0.9 m) higher than the highest part of the roof opening through which it passes.
- ❑ At least 2 feet (0.6 m) higher than any part of the roof within 10 feet (3 m) measured horizontally from the top of the chimney.

This stove requires a minimum chimney height of 13 feet (4 m). The maximum allowable chimney height is 30 feet (9m).

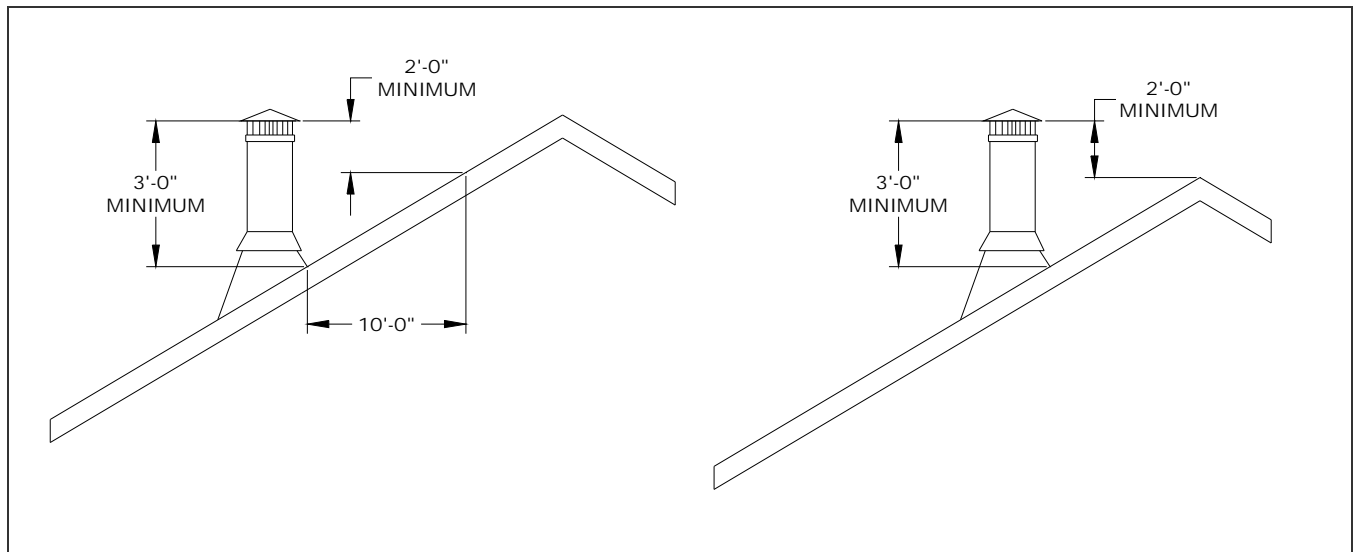

## INSTALLING IN A MOBILE HOME

Follow these special requirements for installing your stove in a mobile home.

- Install the stove in accordance with 24 CFR, Part 3280 (HUD)
- Permanently attach the stove to your mobile home's floor. Use HearthStone's Kit #91-99400 - Mobile Home Lock Down Kit.
- Install one of the following Dura-Vent Mobile Home Chimney & Connector Kits:

6DP-MH 6" Diameter S/N 9096N  
7DP-MH 7" Diameter S/N 9196N  
8DP-MH 8" Diameter S/N 9296N

Each kit includes:

Stainless spark arrester cap, storm collar,  
Adjustable vented flashing – 0/12 – 6/12,  
Two 24" Dura/Plus\* chimney pipes, 24"  
Support box with built-in starter section and trim.

\* (UL or ULC approved equipment is acceptable)

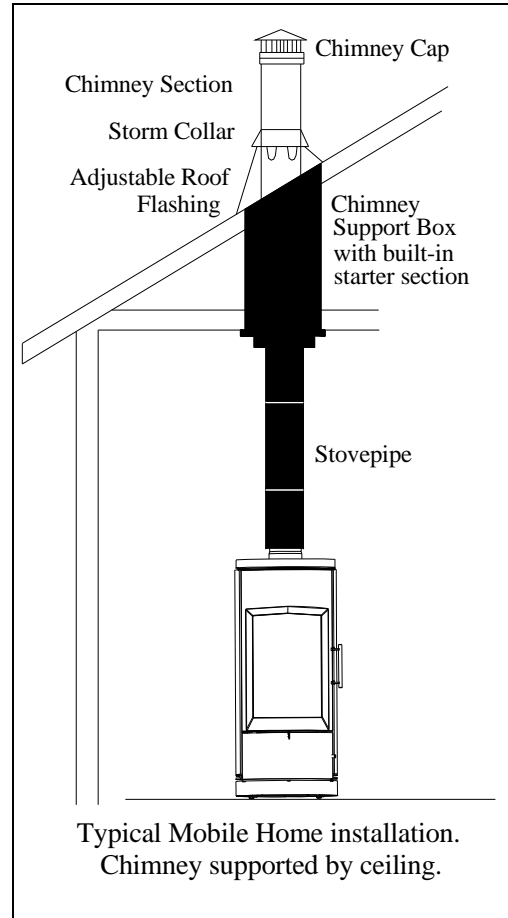

**WARNING:**  
**DO NOT INSTALL IN A SLEEPING ROOM  
IN A MOBILE HOME.**

**CAUTION:**  
**MAINTAIN THE STRUCTURAL INTEGRITY  
OF THE MOBILE HOME WALLS, FLOOR,  
CEILING, AND ROOF WHEN INSTALLING  
AND USING YOUR STOVE.**

**CAUTION:**  
**REMOVE THE CHIMNEY WHEN  
TRANSPORTING THE MOBILE HOME!**

# Operating Your Bari Wood Stove

Once your Bari is set in place, connected, and assembled, you are ready to light a fire. HearthStone tests each wood stove before we ship it, so you will easily light your first fire.

**WARNING:**  
**HOT WHILE IN OPERATION! KEEP CHILDREN, CLOTHING AND FURNITURE AWAY. CONTACT CAN CAUSE SKIN BURNS.**

Read this entire chapter before lighting your first fire. It explains the controls and features of your wood stove, how to choose firewood, and how to use your stove on a daily basis.

## CONTROLS AND FEATURES

Before lighting any fires, become familiar with the location and operation of your stove's controls and features and learn how to use them (See Fig. 9). For your own safety, do not modify these features in any way. *The Bari wood stove radiates heat into the surrounding area. In doing this, the controls of the heater can become very hot. Please use caution when using any of the controls. Do not use the controls unless the stove is cool or you use the provided hearth glove.*

**FRONT DOOR HANDLE:** *(This becomes hot during operation. Use the provided fireplace glove to open the handle while the stove is in use)* The front door allows you to load wood into your stove; a fixed handle operates the front door. To open the door, pull out on the handle and pull the door away from the stove. To latch the door, push the door tightly towards the firebox then continue to push the handle until it latches shut. Gently pull on the door handle to make sure it is properly latched.

**ASH GRATE LEVER:** *(This becomes very hot during operation. It is best to operate the ash removal system after the stove cools.)* To access the lever, open the control door located under the front door. The grate lever is located above the ash pan. Use the ash grate lever to open the ash grate to move the ashes from the firebox to the ash pan. Pull the lever out to open the grate. Once you have sifted the ashes through the grate into the ash pan, push the lever back in towards the stove to close the grate.

**ASH PAN:** *(This becomes hot during operation. It is best to remove the ash pan only after the stove cools.)* To access the ash pan you must open the control door, which is located under the firebox door. Open the control door and locate the ash pan handle. To remove the ash pan, grip the handle, rotate it clockwise ¼ turn, and then pull it out. The lid for the ash pan is stored under the ash pan. Use the lid to contain the ashes during transport for disposal. **The lid must be stored in place under the ash pan to support it, or the pan will not seal properly.** The ash pan collects the ash residue from

each fire and when full, allows you to remove the ash conveniently from your wood stove. Clear the firebox of ashes periodically by opening the ash grate in the bottom of the firebox. Sift the ashes through the grate into the ash pan, and then return the grate to its closed position.

To replace the ash pan, place the pan lid back into the bottom of the ash pan receptacle and slide the ash pan back into place on top of the lid. The lid must be upright to support the ash pan properly. Turn the ash pan handle counter-clockwise ¼ turn to tighten the seal around the pan and hold the pan in place.

**Do not operate the stove unless the ASH PAN is in place, and properly sealed. Not doing this could overheat and damage the stove.**

**PRIMARY AIR CONTROL:** *(This becomes hot during operation. It is best to operate the primary air system with the provided fireplace glove, or after the stove is cool.)* The primary air control handle is located on the front lower right of the stove, just under the ash pan. The primary air control allows you to regulate the amount of air entering the firebox. Generally, the more air allowed into the firebox, the faster the rate of burn; conversely, less air creates a slower burn. For maximum air flow, pull the primary air handle as far out as possible; push the primary air control handle in as far as possible for minimum air flow (does not close completely).

**ROTATION CONTROL:**

Your Bari rotates a full 180 degrees. With the stove centered on your hearth, it will rotate 90 degrees to the left and 90 degrees to the right.

To access the rotation control you must open the control door that is located under the firebox door. Open the control door and locate the flip-down lever. Push down on the lever to free the unit to rotate to the position you desire. Once the stove is in position, release the lever and slightly turn the stove to ensure it locks into position. If the stove is positioned as you like, close the control door and enjoy the fire.

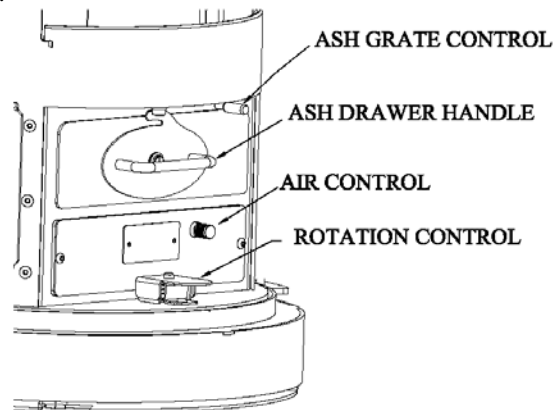

Figure 9 Controls

## CHOOSING FIREWOOD

Your Bari Wood Heater is designed to only burn firewood—also known as cordwood.



### CAUTION:

**DO NOT USE CHEMICALS OR FLAMMABLE FLUIDS SUCH AS GASOLINE, NAPHTHA, KEROSENE, CHARCOAL LIGHTER FLUID OR ENGINE OIL TO START A FIRE. DO NOT USE CHARCOAL, PELLETS, COAL, ARTIFICIAL LOGS OR ANY OTHER MATERIALS AS FUEL; THEY ARE NOT SAFE. DO NOT BURN GARBAGE.**

The quality of your firewood directly affects heat output, duration of burn and performance of your stove. Softwoods generally burn hotter and faster, while hardwoods burn longer and produce better coals. Density and moisture content are two critical factors to consider when purchasing wood for your stove.

The following is a list of some wood species and their relative BTU (British Thermal Unit) content. The higher the BTU content, the longer the burn. Firewood with higher BTUs is generally ideal for a wood stove.

*HIGH:* Apple, Black Birch, Hickory, Locust, White Oak, Black Beech, and Mesquite

*MEDIUM HIGH:* White Ash, Beech, Yellow Birch, Sugar Maple, and Red Oak

*MEDIUM LOW:* Black Ash, White Birch, Grey Birch, Elm, Norway Pine, Pitch Pine, Black Cherry, Soft Maple, Tamarack

*LOW:* White Pine, White Cedar, Balsam Fir, Spruce, Aspen, Basswood, Butternut, Hemlock

Moisture content also plays a key role in the performance of your stove. Wood freshly cut from a living tree (green wood) contains a great deal of moisture. As you might expect, green wood burns poorly. You must season green wood before using it in your wood stove. To season green wood properly, split, stack, and allow it to air dry for a period of one year.

Stack the firewood on skids or blocks to keep it off the ground, cover only the top of the stack. Plastic or tarps that cover the sides of the woodpile trap moisture and prevent the wood from drying. As for stacking, an old Vermonter said, "The spaces between the logs should be large enough for a mouse to get through, but not for the cat that's chasing it."



### CAUTION:

**DO NOT STORE FIREWOOD WITHIN THE STOVE'S SPECIFIED CLEARANCES TO COMBUSTIBLE MATERIALS.**

## BUILDING A FIRE

Once you understand the controls of your wood stove and have the appropriate firewood, you are ready to start a fire.

When you light your first fires, the woodstove will emit some smoke and fumes. This is normal "off-gassing" of the paints and oils used when manufacturing the woodstove. If you find it necessary, open a few windows to vent your room. The smoke and fumes will usually subside after 10 to 20 minutes of operation. The odor and smoke will end once the stove is "cured".

The first fires may produce other odors from impurities that exist in the area immediately surrounding the stove. Some potential impurities are cleaning solvents, paint solvents, cigarette smoke, and soot from scented candles, pet hair, dust, adhesives, a new carpet, and new textiles. These odors will dissipate over time. You can alleviate these odors by opening a few windows or otherwise creating additional ventilation around your stove. If any odor persists, contact your dealer or an authorized service technician.

If you adhere to the operating procedures in this manual, the steel, cast iron, and soapstone components of your stove will give you many years of trouble-free use. With use, the color of the soapstone will change and small fractures may appear on the surface of the stone. These changes will only add character and distinction to your stove.

Avoid the following conditions that can cause the glass, soapstone, steel or cast iron pieces to break:

- Do not throw wood into the stove.
- Do not use the door for leverage to force wood into the stove.
- Do not load wood encrusted with ice into a burning stove - the thermal shock can cause damage.
- Do not use a manufactured log grate. Burn the fire directly on the cast iron bottom of the firebox.



## NORMAL OPERATION

Prior to loading the stove, make sure the ash grate and the ash pan door are closed. If left open, the stove will over-fire and will suffer damage.

### BUILDING A FIRE FOR EVERYDAY USE

- 1) Open the front door and place five or six double sheets of tightly twisted newspaper in the center of the firebox. Arrange kindling in a tee-pee configuration over the newspaper. Use approximately 10 pieces of kindling, 1/2" (13 mm) in diameter and 10" to 16" (254 mm to 406 mm) long.
- 2) Fully open the primary air control by pulling it completely out, away from the firebox.
- 3) Light the paper under the kindling. Leave the front door slightly ajar momentarily until the kindling begins to burn and draft begins to pull.
- 4) Close the door and allow the fire to burn.
- 5) Once the kindling is burning, open the front door and add logs, small at first, to build the fire up. Ensure you keep the logs away from the glass in front in order for the air-wash system to work properly. Keep the front door and ash pan closed while the stove is in use.
- 6) Once the fire is burning well, use the primary air control to regulate the desired rate of burn. Pull the handle out to open the primary air control for a high rate of burn; or push it in for a low rate of burn. The air control does not close completely.

Note: When opening the front door to reload or rearrange logs, it is advisable to open the door just a crack, pause for a moment then open the door completely. This procedure allows the firebox to clear of smoke before the door is open fully. In addition, reloading on a bed of hot, red coals reduces smoking time and brings fresh fuel up to a high temperature rapidly.

### BURN RATE

**HIGH BURN:** Fully load the firebox with wood on a bed of hot coals or on an actively flaming fire and fully open the primary air control by pulling it all the way out, away from the firebox. A high burn rate once or twice a day to heat the stovepipe and chimney fully, will help minimize creosote accumulation.

**MEDIUM HIGH BURN:** With the primary air control in the open position, push the control handle slightly towards the firebox, or about ¼ to ½ the way in.



**MEDIUM LOW BURN:** With the primary air control in the open position, push the handle inward about ¾ of the way in. A medium-low burn rate is the typical setting and is preferable if the stove is unattended.

**LOW BURN:** Push the primary air control inward all the way to the firebox. This closes the air shutter to its minimum opening. A low burn rate over extended periods is not advisable as it can promote the accumulation of creosote. Inspect the venting system frequently if using low burn rates consistently.

### OVER-FIRE CAUTION

Over-firing means the stove is operating at temperatures above the recommended temperatures outlined in the *BURN RATE* section. Carefully avoid over-firing, as it will damage the stove. Symptoms of chronic over-firing can include warped components, short burn times, a roaring sound in the stove or stovepipe, and discoloration of the stovepipe.

Excessive draft, inappropriate fuel, and operator error can cause over-firing. Correct an over-fire situation as follows:

-  **EXCESSIVE DRAFT:** Contact your local dealer to have a draft reading taken. Any draft in excess of 0.1 WC requires a damper in the stovepipe. Some installations may require more than one damper.
-  **INAPPROPRIATE FUEL:** Do not burn coal; kiln dried lumber, wax logs or anything other than natural cordwood.
-  **OPERATOR ERROR:** Ensure all the gaskets are in good condition. Replace worn out or compressed gaskets. Do not burn the stove with the front door, ash pan, or the ash grate in the open position.

If you suspect that your stove is over-firing, contact your dealer immediately. **Damage caused by over-firing is not covered by your warranty.** Results of over-firing can include warped or burned out internal parts, cracked vermiculite panels, discolored or warped external parts, and damaged finish.

### REMOVAL AND DISPOSAL OF ASHES

Remove ashes only when the stove is cold. Use protective fireplace gloves if the ash pan is warm. Exercise extreme caution when handling, storing or disposing of ashes.

The ash pan is located behind the control door. The ash pan collects burned ash from a fire and allows you to remove the ash conveniently from your wood stove. Clear the firebox of ashes often, and do not let them build up more than 3 inches high. It is important to prevent ashes from building up around the front door opening. To remove ashes, pull the grate lever out to open the grate. Sift the ashes across the grate into the ash pan. Then return the ash grate to its closed position by pushing the lever back in towards the stove. The ash pan is easy to remove and has a handle and lid for convenient disposal of ashes. The lid must be stored under

the ash pan when burning the stove. The ash pan will not seal properly without the lid under it.

Dump ashes from the ash pan directly into a **metal** container with a tight fitting lid. Do not place any other items or trash into the metal container. Do not pour water into the container. Replace the container's lid and allow the ashes to cool. Never place the ash disposal container on a combustible surface or vinyl flooring, as the container could be **hot!**

Pending disposal, place the closed ash container on a noncombustible floor or on the ground, well away from all combustible materials, liquid fuels, or vehicles. Retain ashes in the closed container until all coals thoroughly cool.

 **NEVER** place ashes in wooden or plastic containers, in trashcans with other trash, or in paper or plastic bags, no matter how long the fire has been out. Coals within a bed of ashes can remain hot for several days once removed from the firebox.

## MAINTENANCE

 **NOTE: ANY SYMPTOMS OF OVER-FIRING WILL VOID YOUR WARRANTY!**

### CREOSOTE FORMATION AND NEED FOR REMOVAL

When wood burns slowly at low temperatures, it produces tar and other organic vapors, which combine with expelled moisture to form creosote. These creosote vapors condense in the relatively cool chimney flue of a slow-burning fire. As a result, creosote residue accumulates on the flue lining. When ignited, this creosote makes an extremely hot fire, which may damage the chimney or even destroy the house. When burning wood, inspect the chimney connector and chimney at least once every two months during the heating season to determine if there is a creosote buildup.

To prevent the buildup of creosote:

Burn the stove with the primary air control fully open for 35 - 45 minutes daily to burn out creosote deposits from within the stove and the venting system.

After reloading with wood, burn the stove with the primary air control fully open for 20 to 30 minutes. This manner of operation ensures early engagement of the secondary combustion system that minimizes creosote buildup in the chimney.

If a creosote build-up occurs, inspect the stovepipe connector and chimney more often, at least monthly during the heating season to monitor the accumulation. If a creosote residue greater than 1/4" (6 mm) accumulates, remove it to reduce the risk of a chimney fire.

If your glass always remains dirty, your operating temperatures are too low or your wood is wet; therefore, there is a higher risk of creosote buildup.

Inspect the venting system at the stove connection *and* at the chimney top. Cooler surfaces tend to build creosote deposits faster, so it is important to check the chimney at the top (where it is coolest) as well as from the bottom near the stove.

Remove accumulated creosote with a cleaning brush specifically designed for the type of chimney in use. Use a certified chimney sweep to perform this service. Contact your dealer for the name of a certified chimney sweep in your area (your dealer may be a certified sweep!).

We recommend that before each heating season you have the entire system professionally inspected, cleaned and repaired, if necessary.

### DOOR REMOVAL PROCEDURE:

1. Open the door and remove the push nut from the upper hinge pin, and remove the pin.
2. Tilt the top of the door outward, and then lift the door up off the lower pin. The door weighs 81 pounds (37 kg) – so use a helper if necessary.
3. Ensure the brass washer remains in place on the lower pin.
4. Place the door face down on a padded work surface. Use two rolled up towels, or similar, under the door to stabilize the curved door during maintenance.
5. When reinstalling the door, use a new push nut on the upper hinge pin.

### GASKETS

Replace door gasket material every two to three seasons, depending on stove use. If the door seal leaks, a new gasket will ensure a tight seal and improve stove performance.

We recommend you only use HearthStone Hase Collection replacement gaskets and adhesive when you need to replace your door gasket. Contact your dealer for a gasket kit that includes instructions, adhesive, and the gasket for your stove.

**Required Door Gasket:** Part Number: 3110-200752, 79" (200cm) Length, 9/16" (14 mm) Diameter.

### DOOR GASKET REPLACEMENT PROCEDURES:

1. To replace the door gasket, remove the door from the stove (see door removal instructions above), and remove the door's side plates. Pull off the old rope gasket. Carefully remove any old gasket material and adhesive with a small screwdriver, or cold chisel and a hammer. Clean all gasket channels with a small wire brush if necessary.
2. Vacuum the inside of the door as required. Loosely re-attach the door's side plates.
3. Apply a 1/8-inch (3mm) bead of gasket adhesive to the channels. Fold the provided gasket rope in half to find its center point. Start at the top or bottom center of the door and push the new gasket into place uniformly without stretching or compressing the gasket material. Pinch the gasket into place as necessary. Use masking tape to hold

the rope in the channel along the top and bottom of the door.

4. Once the gasket is installed, tighten the door's sidepieces to clamp the gasket in place. The sidepieces form one side of the gasket's channel, and hold the gasket rope along the sides in place.
5. Re-install and close the door immediately to fully seat the gasket in the channel and ensure complete adhesion. Check the gasket seal using a dollar bill or aim a flashlight into the space around the door from the outside (then look in through the glass at the gasket – if you see light, the seal will leak). The leak will most likely be where the gasket was not fully inserted into the channel, or where stretched (thinner), or adjacent to an area where the gasket was compressed (thicker).
6. First, adjust the gasket as necessary by reseating it uniformly. If that does not work, adjust the latch mechanism (see below and Fig. 10 and 11) so it applies more pressure when the door is closed. Keep the door closed and do not burn the stove for 24 hours while the adhesive cures.
7. Remove the tape before burning the stove.

#### LATCH ADJUSTMENT PROCEDURES:

1. Test gasket seal quality with small latch adjustments first. The curved door geometry means a little movement goes a long way. Too much pressure makes the door difficult to open and close and prematurely wears the roller and the gasket.
2. Loosen bolts, adjust jackscrews, or use a combination of both to shift the latch assembly to apply more, or less closing pressure to the gasket (See Fig. 10).
3. If necessary, loosen the five bolts securing the door side plate containing the handle (mounting holes are slotted). Make additional adjustments by sliding the side plate in towards the stove (less pressure), or out away from the stove (more pressure) (See Fig. 11).

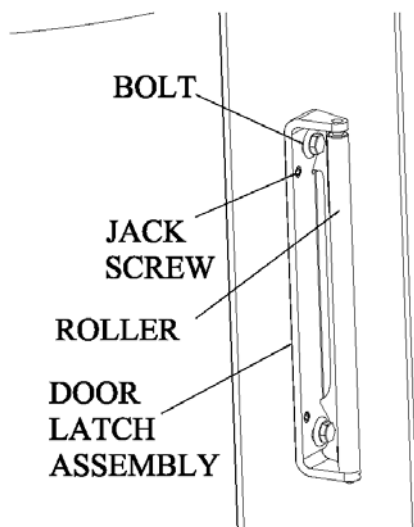

Figure 10 Latch Assembly Detail

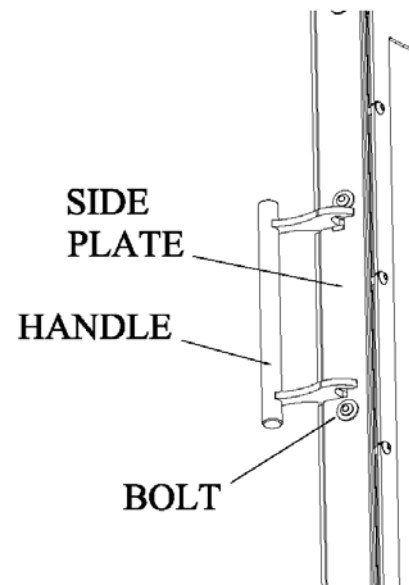

Figure 11 Handle Assembly Detail

#### GLASS

Do not operate the stove with a broken door glass. Do not abuse the front door by striking or slamming.

When necessary, clean the glass with commercial stove glass cleaners, which are available from your local dealer. Never attempt to clean the glass while the fire is burning or while the glass is hot. Remove deposits by following the instructions provided with the cleaner. To clean heavier, stubborn deposits, remove the door from the stove (See door removal procedures on page 18). Lay the door face down on a clean, padded workbench or table, use rolled up old towels, or similar, to stabilize the curved door so the heavy deposits are at the lowest point. Apply the cleaner to the glass and allow it to soak for a few minutes. Reposition the door as necessary to allow the cleaner to penetrate all the heavy deposits. Wipe the cleaner off with a soft cloth, or black & white newsprint.

**Important:** scratching or etching the glass will weaken the integrity of the glass. Do not use a razor blade, steel wool, or any other abrasive material to clean the glass. Use a cleaner specifically manufactured for woodstoves only.

The front door glass is a ceramic, shock-resistant glass, made specifically for use in woodstoves. Do not use any replacement glass other than the ceramic glass manufactured and supplied for use in this woodstove. Replacement glass is available through your local dealer.

Replace the door glass immediately if broken or chipped. Contact your local dealer for replacement glass. The glass kit includes instructions and everything needed for the repair. If you replace the glass yourself, wear work gloves and safety glasses.

**Required Glass Kit:** Part Number: 040-057-V (Glass with gasket applied).

**GLASS REPLACEMENT PROCEDURES:**

1. Follow the instructions included with the replacement glass kit.
2. Remove the door (see door removal procedure on page 18).
3. Remove the screws from the glass retainer (use penetrating oil if necessary) – lift the retainer off the glass. Set aside for reinstallation.
4. Remove the inner glass frame from around the glass. Set aside for reinstallation.
5. Carefully lift the damaged glass out of the door and discard.
6. Remove any remaining glass and old gasket material.
7. Clean the screw holes and place a small amount of anti-seize compound in each one.
8. Place the gasketed new glass onto the door.
9. **Important! Center the glass** and ensure that the edges of the curved glass are parallel with the edges of the opening.
10. Reinstall the inner glass frame (limits pressure on glass from the retainer).
11. Check glass position again (centered, and parallel), then screw the glass retainer back on the door using a crisscross pattern. Tighten the screws no more than 1/8<sup>th</sup> of a turn after they seat. (The glass will break at this point if not positioned correctly. If the glass shifts too much to one side, you will see the gasket from the outside)
12. Apply a light film of anti-seize lubricant on the door’s hinge pins and washer if needed.
13. Install the door.
14. After 5 or 6 fires, check the glass retainer screws, and retighten if necessary.

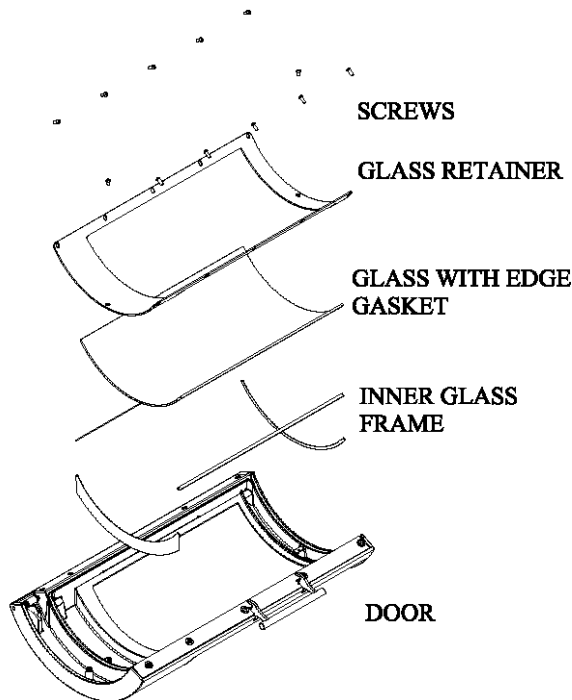
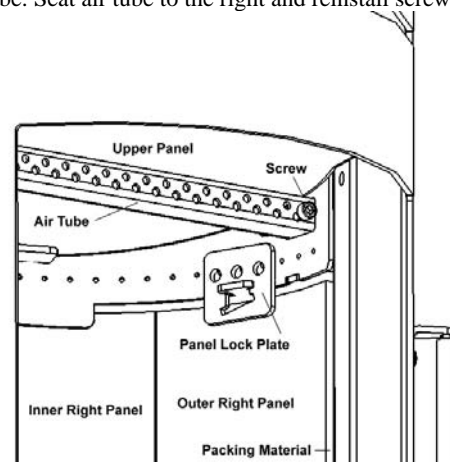

**Figure 12 Glass Assembly**

**VERMICULITE PANEL REPLACEMENT:**

1. Remove packing material from spaces along front edges of the outer left and outer right panels.

2. Remove the panel lock plate above the outer right panel.
3. Slide outer right panel slightly to the right, tilt top into firebox, and remove the panel.
4. Slide all other panels to the right, tilt, and remove.
5. To remove the upper panel, remove the screw securing the air tube, slide the air tube to the left, and remove it. Drop down the upper panel.
6. Install the side panels by placing each one into the right most position and then slide it to the left. All side panels are identical.
7. Replace side panel lock plate.
8. Push side panels together tightly and center them so the spaces along the front edges are equal, Insert packing to prevent panel separation.
9. To install the upper panel, insert the panel rear edge first into the space below the baffle plate – hold in place and insert the air tube. Seat air tube to the right and reinstall screw.



**Figure 13 - Panel Detail**

**STONE**

The stone panels on this stove are large and heavy (150 pounds total). Use a second person to assist in mounting the panels to avoid injury, or damaging the panels. Despite the mass of each piece of soapstone, they will break if dropped.

Occasional cleaning is all that is necessary to maintain the natural beauty of your stove’s soapstone finish. Clean the soapstone with water, any non-abrasive cleaner and a soft cloth. Wipe dust from the stone with a clean cloth. Do not use chemical agents to wash the stone; do not use waxes or any polishing agents on the stone.

Take care not to scratch or chip the soapstone. Do not set items that can scratch or chip the stone on top of your stove. You can use 240 grit sandpaper to easily repair, or blend in minor scratches

Often, with use and over time, subtle earth tones of brown, red, and yellow may appear in the soapstone. This is a natural reaction in the soapstone. Surface or hairline fractures may also appear in the stone after a stove is used. Such changes are normal and do not affect the operation or the integrity of the stove and do not require replacement. If you observe a completely broken stone, contact your dealer for service.

# TROUBLESHOOTING

## Common Issues

Virtually all woodstove operators experience basic common problems at one time or another. Most are correctable and generally require only a minor adjustment of the stove, installation, or operating technique. In cases where weather conditions dramatically affect stove performance, the problems are typically temporary and solve themselves once the weather changes.

If you question whether your stove is producing adequate heat, the best way to troubleshoot the problem is to monitor the temperature of the stack no more than 12 inches (30 cm) above the flue collar. A 400° F (200° C) stovepipe confirms the stove is supplying sufficient heat. Keep in mind that your house itself will regulate room/house temperatures. How well the walls, floors and ceilings are insulated, the number and size of windows, the tightness of outside doors, and the construction or style of your house (vaulted ceilings or other open spaces which collect large percentages of heat, ceiling fans, etc.) all are determining factors of room temperature.

Your stove's performance is also dependant on its installation. One common cause of poor performance is an oversized chimney flue. Oversized chimney flues result in decreased draft, which prevents the smoke from rising out the chimney. Oversized flues are also more difficult to heat effectively, especially when burning a high efficiency stove. Cool flue temperatures inhibit the establishment of a strong draft (and encourage the accumulation of creosote). The lack of a strong draft will cause the fire to die down and may even force smoke to pour into the room.

If your chimney is the proper size and a strong draft is not easily established, there is the possibility that the chimney is too cold. Again, hot chimneys promote stronger drafts. Opening a window briefly while lighting the stove may help.

Other draft guidelines are as follows:

**An "AIRTIGHT" HOUSE:** The air supply (infiltration) to the interior of the house may be inadequate if your home is super-insulated or especially well sealed. This phenomenon of air starvation within the building is exacerbated if exhaust

fans, such as clothes dryers, bathroom fans or cookstove exhaust fans, are in operation within the home. Outfitting your stove with the optional outside air adaptor connected to an air duct, which leads to the outside of the building, can correct this problem.

**TALL TREES OR BUILDINGS:** These obstructions, when located close to the top of the chimney can cause chronic or occasional downdrafts. When selecting a site for a new chimney, consider the placement of other objects near the proposed chimney location.

**WIND VELOCITY:** Generally, the stronger and steadier a wind, the stronger (better) the draft. However, "gusty" wind conditions can cause erratic downdrafts. For consistent problems, consider a high wind cap, such as the Vacu-Stack.

**BAROMETRIC PRESSURE:** Chimney drafts are typically sluggish on balmy, wet or muggy days (low barometric pressure). This is a weather-related phenomenon, which generally is self-correcting as the weather changes.

**BRISKNESS OF FIRE:** The hotter the fire in your stove, the hotter your chimney and, therefore, the stronger the draft.

**BREAKS IN THE VENTING SYSTEM:** An unsealed clean-out door at the bottom of the chimney, leaky stovepipe joints, a poor stovepipe-to-thimble connection, missing caps, or a leaky chimney all can cause inadequate draft.

**SEASONAL FACTORS:** Early fall and late spring are generally difficult seasons in which to establish proper drafts. The colder the outside air is relative to room temperature, the stronger the draft.

## Operating the Stove

As outlined above, there are days when a good draft is just not easy to establish. The causes are usually seasonal factors or a cold chimney. Try starting the fire by using small kindling and fuel to obtain a quick, hot fire. Tend the fire frequently with small fuel until the chimney is hot and the draft is well established. Sometimes, partially opening a first floor window briefly will help quickly get draft established.

## TROUBLESHOOTING GUIDE

<b><u>PROBLEM</u></b>	<b><u>POSSIBLE CAUSE</u></b>	<b><u>SOLUTIONS</u></b>
STOVE SMOKES	Operating Technique	Fully open the primary air control one minute before opening doors.
	Cold Chimney	Preheat the chimney when first starting a fire. Briefly open a window in the room containing the stove.
	Blocked Chimney	Examine the chimney and stovepipe for blockage or creosote accumulations.
	Oversized Chimney	Reline the chimney to the appropriate diameter
	Undersized Chimney	Install a draft inducer or replace the chimney.
	Chimney Too Short	Lengthen the chimney.
	Air Infiltration Into The Chimney	Seal chimney connections and openings in clean-out doors.
	More Than One Appliance Connected to the Flue	Disconnect all other appliances and seal openings.
BACK-PUFFING OR GAS EXPLOSIONS	Operating Technique	Fully open the primary air control one minute before opening the door and keep it fully open for a few minutes after reloading.
	Extra Low Burn Rate	Burn the stove at a higher burn rate.
	Chimney Down-draft	Install a chimney cap.
	Excessive Ash Build-up	Empty the ash pan more frequently. Increase efficiency of burns, and avoid using poor quality or green wood.
UNCONTROLLED OR SHORT BURN	Unsealed or Open Door Open ash grate	Close the door tightly or replace the gaskets. Slide ash grate to closed position.
	Excessive Draft	Check the installation. Operate at LOW BURN. Install stovepipe damper.
	Extra Long Chimney	Shorten the chimney. Install stovepipe damper(s).
	Oversized Chimney	Reline the chimney to the proper diameter.
	High Winds or Hilltop Location:	Install a chimney cap.
	Excessive Draft	Draft in excess of 0.1 wc should be corrected with a stovepipe damper(s)
INSUFFICIENT HEAT	Poor Quality or Green Wood	Use only air-dried wood, preferably dried <u>at least</u> one year.
	Low Burn Rate	Operate the stove at a higher burn rate.
	Air Insulated Chimney	Replace with a pre-fabricated insulated chimney system or a properly sized masonry chimney.
	Cold Exterior Chimney	Reline or insulate the chimney.
	Leaky Stovepipe or Chimney	Check the installation.
	Too Much Heat Loss From House	Add insulation, use energy efficient windows, or caulk windows, and seal openings in home.
	Excessive Ash Build-up	Empty the ash pan more frequently. Increase efficiency of burns, and avoid using poor quality or green wood.
BLISTERING OF FINISH	Operating Technique	Do not over-fire the stove. Monitor stove temperatures. Use seasoned wood only.
	Excessive Draft	Check the DRAFT. A damper may be required. Operate the stove at a LOW BURN range.

## REPLACEMENT PARTS & OPTIONAL ACCESSORIES

PART #	DESCRIPTION	PART #	DESCRIPTION
595-274-V	BAFFLE	565-132	REAR INNER AIR DUCT
595-377-V	SECONDARY AIR SUPPORT	565-133-V	SECONDARY AIR RING ASSEMBLY(W/PIPE)
595-379-V	STONE LEVELING PLATE	565-137-V	INNER AIR DUCT
595-278-V	FRONT DOOR TOP HINGE PLATE	575-184	FIREBOX JACKET
595-284-V	FRONT DOOR TOP HINGE PIN (.31"X .98")	800-013-V	ASH TRAY
605-132-V	ASH PAN FAÇADE	601-422-V	LEFT SUPPORT
635-011-V	ASH GRATE, ROTATING	601-425-V	RIGHT SUPPORT
635-052-V	ASH GRATE BASE	780-017-V	UPPER BAFFLE
635-053-V	GRATE ROD	3917-100125	GLOVE
650-047-V	AIR CONTROL SHUTTER	6400-40459	OWNERS MANUAL
505-064-V	BASE PLATE		
530-120-V	TOP PLATE	SP-150GR	AEROSAL PAINT GREY
170-050-V	VERMICULITE PANEL SET		
180-218-V1	SIDE PANEL (4 EA)		
180-240-V	TOP PANEL		
	<b>OPTIONAL ACCESSORIES</b>		
91-53700	OUTSIDE AIR KIT		
91-99400	MOBILE HOME BOLT DOWN KIT		
	<b>STONE</b>		
1141-820-149-V	RIGHT STONE PANEL		
1141-820-150-V	LEFT STONE PANEL		
1141-820-148-V	TOP STONE RING		

# Safety Label

CONTACT YOUR LOCAL BUILDING AND INSTALLATION



OFFICIALS ABOUT RESTRICTIONS INSPECTION IN YOUR AREA

Listed Room Heater, Solid Fuel Type  
Also Suitable for Mobile Home Installation Pursuant to (UM) 84-HUD



Intertek Testing Services NA, Inc.

Manufactured for:



By: HASE-Kaminofenbau GmbH  
Niederkircher Str. 14 D-54294 Trier  
Germany

## "PREVENT HOUSE FIRES"

Install and use only in accordance with manufacturer's installation instructions and your local building codes.

**CAUTION:** Special methods are required when passing chimney through a wall or ceiling, refer to local building codes. Do not connect this unit to a chimney flue serving another appliance.

**NOTE:** Replace glass only with 4mm CERAMIC or NEOCERAM glass.

**WARNING: (MOBILE HOME)** An outside air inlet must be provided for combustion and be unrestricted while unit is in use.

SERIAL # 0001



MODEL NAME: BARI 8170

TESTED TO: UL 1482, ULC S627

TYPE OF FUEL: Solid Wood Only

## WARNINGS:

- Do not operate with doors open.
- Do not use grate or elevate fire. Build wood fire directly on hearth.
- Keep ash grate closed when not in use.
- Do not overfire. If the heater or chimney connector glows, you are overfiring.

## Clearance to Combustible Materials\*

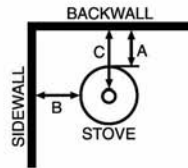

- A - 17" (18cm)
- B - 38" (43cm)
- C - 23" (33cm)

When installed on a combustible floor, non-combustible floor protection is required to:

- A. Cover the area beneath the heater, and extend at least 16" (18" Canada) to the front and 8" to the sides of the fuel opening.
- B. Cover the area beneath the chimney connector and 2" beyond each side.

\* Refer to the Installation Manual for additional clearance information.

## VENT REQUIREMENTS:

Use only a lined masonry, or listed Type HT factory-built chimney. Use 24-ga. Black chimney connector.

## OPTIONAL KITS:

- Outside Air Kit Kit # 91-53700
- Mobile Home Kit Kit # 91-99400

## FLOOR PROTECTION

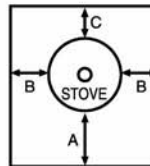

- A - 16" (18" CAN)
- B - 16" (18" CAN)
- C - 4.5" (4.5" CAN)



**CAUTION:** HOT WHILE IN OPERATION. DO NOT TOUCH. KEEP CHILDREN, CLOTHING AND FURNITURE AWAY. CONTACT MAY CAUSE SKIN BURNS. SEE NAMEPLATE AND INSTRUCTIONS. INSPECT AND CLEAN CHIMNEY AND CONNECTOR FREQUENTLY. UNDER CERTAIN CONDITIONS OF USE, CREOSOTE BUILDUP MAY OCCUR RAPIDLY.

U.S. ENVIRONMENTAL PROTECTION AGENCY  
Certified to comply with July 1, 1990 particulate emissions standards

Date of Manufacture  
2007 2008 2009 Jan Feb Mar Apr May Jun Jul Aug Sep Oct Nov Dec

DO NOT REMOVE OR COVER THIS LABEL

3300-588 Rev. A (IGN)



# HEARTHSTONE WOODSTOVE LIMITED WARRANTIES

## HearthStone Hase Collection Wood Stove Warranty

### **2-year limited warranty**

HearthStone warrants the following parts of the Stove against the following occurrences that result from defects in material or workmanship:

- 🔥 Ceramic glass against cracking due to thermal shock.
- 🔥 Vermiculite panels that break due to thermal stress and fall into the firebox.

*This warranty expires on the second (2<sup>nd</sup>) anniversary of the purchase date.*

### **5-year limited warranty**

HearthStone warrants the following parts of the Stove against the following occurrences that result from defects in material or workmanship:

- 🔥 All steel parts against cracking or burn-through
- 🔥 All cast iron parts against breakage.

*This warranty expires on the fifth (5<sup>th</sup>) anniversary of the purchase date.*

### **These warranties do not cover the following:**

- 🔥 Damage caused during shipment.
- 🔥 Damage resulting from incorrect installation or operation (non-observance of the operating instructions).
- 🔥 Damage or poor function resulting from faulty and/or incomplete setup and installation and from faulty start-up or misuse of the Stove, including but not limited to over-firing of the Stove.
- 🔥 Damage resulting from installation, modification, alteration, repair or service.
- 🔥 Damage due to water or to installation of the Stove in damp rooms or in damp environments, including high ambient humidity.
- 🔥 Damage due to installation of the Stove in an atmosphere contaminated by chemicals, including but not limited to chlorine, fluorine compounds or salts.
- 🔥 Scratches and damage on glass, steel surfaces/steel components and vermiculate panels due to mechanical wear.
- 🔥 Standard wear and tear of the stressed components resulting from normal usage of the Stove.
- 🔥 Damage, operational-related problems or inadequate performance caused by poor fuel quality, site, installation or environmental influences, including but not limited to nearby trees, roof tops, buildings, wind, hills, mountains, inadequate or excessive venting, insufficient make-up air or negative air pressure whether or not caused by exhaust fans, clothes dryers etc.

### **Additional exclusion of any liability is for the following:**

- 🔥 Grit leaking during transportation and installation of the Stove.
- 🔥 Occurrence of odors during the first hours of operation resulting from the process-related "baking" of the stove paint and surrounding environment.
- 🔥 Occurrence of noises (click and pop sounds) due to expansion/contraction during the heating-up and cooling-down phases.

**Notes:**