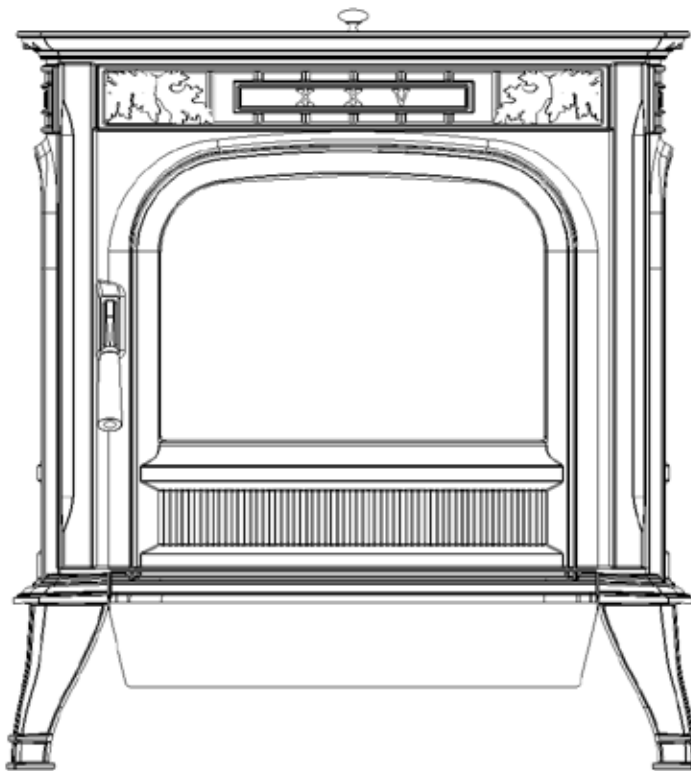


Installation & Operating Manual

XXV Pellet Stove Owners Manual

HARMANTM
HOME HEATING



We suggest that our hearth products be installed and serviced by professionals who are certified in the U.S. by the National Fireplace Institute (NFI) as NFI Specialists.



SAFETY NOTICE

PLEASE READ THIS ENTIRE MANUAL BEFORE YOU INSTALL AND USE YOUR NEW ROOM HEATER. FAILURE TO FOLLOW INSTRUCTIONS MAY RESULT IN PROPERTY DAMAGE, BODILY INJURY, OR EVEN DEATH.

FOR USE IN THE U.S. AND CANADA. SUITABLE FOR INSTALLATION IN MOBILE HOMES.

IF THIS HARMAN STOVE IS NOT PROPERLY INSTALLED, A HOUSE FIRE MAY RESULT. FOR YOUR SAFETY, FOLLOW INSTALLATION DIRECTIONS.

CONTACT LOCAL BUILDING OR FIRE OFFICIALS ABOUT RESTRICTIONS AND INSTALLATION INSPECTION REQUIREMENTS IN YOUR AREA.

CONTACT YOUR LOCAL AUTHORITY (SUCH AS MUNICIPAL BUILDING DEPARTMENT, FIRE DEPARTMENT, FIRE PREVENTION BUREAU, ETC.) TO DETERMINE THE NEED FOR A PERMIT.

CETTE GUIDE D'UTILISATION EST DISPONIBLE EN FRANCAIS. CHEZ VOTRE CONCESSIONNAIRE DE HARMAN HOME HEATING.

SAVE THESE INSTRUCTIONS

3-90-00684

Fuel Specifications

Fuel and Fuel Storage

Pellet fuel quality can fluctuate from manufacturer to manufacturer, and even from bag to bag. Hearth & Home Technologies recommends using only fuel that is certified by the Pellet Fuels Institute (PFI).

Fuel Material

- Made from sawdust and/or other wood by-products
- Shelled field corn (when mixed with wood pellets)
- Source material typically determines ash content

Higher Ash Content Material

- Hardwoods with high mineral content
- Bark and leaves as source material
- "Standard" grade pellets, corn and other biomass

Lower Ash Content Material

- Softwood; pine, fir, etc.
- Materials with lower mineral content
- "Premium" grade pellets

Shelled field corn

- Must be 15% moisture content or less
- Must be clean and free of debris
- Must be mixed with wood pellets. (Up to 50%)
- Stalk parts, excessive fines and cob remnants may cause feed system jams or blockage

CAUTION! Do not burn fuel that contains an additive; (such as soybean oil)

- May cause hopper fire
- Damage to product may result

Read the list of ingredients on the packaging. If you are buying field corn, the only ingredient listed should be field corn.

WARNING! Risk of Chemical Poisoning!

Do **NOT** burn treated seed corn

- Chemical pesticides are harmful or fatal if swallowed
- Burning treated seed corn will void the product warranty

Clinkers

Minerals and other non-combustible materials, like sand, will turn into a hard glass-like substance when heated. Trees from different areas will vary in mineral content. For this reason, some fuels will produce more clinkers than others.

Moisture

Always burn dry fuel. Burning fuel with high moisture content takes energy to dry and tends to cool the appliance thus, robbing heat from your home. Damp pellet fuel could turn back into sawdust which does not flow properly through the feed system.

Size

- Pellets are either 1/4 inch or 5/16 inch (6-8mm) in diameter
- Length should be no more than 1-1/2 inches (38mm)
- Pellet length can vary from lot to lot from the same manufacturer

Performance

- Higher ash content requires more frequent maintenance.
- "Premium" grade pellets will produce the highest heat output.
- Burning pellets longer than 1-1/2 inches (38mm) can cause inconsistent feeding and/or ignition.

We recommend that you buy fuel in multi-ton lots whenever possible. However, we do recommend trying different brands prior to purchasing multi-ton lots, to ensure your satisfaction.

CAUTION! *Tested and approved for use with wood pellets and a mixture of shelled field corn and wood pellets ONLY. Burning of any other fuel will void your warranty.*

When changing from wood pellets to a corn/pellet mixture, the FEED ADJUSTER will likely need adjusted to a lower setting. When under maximum demand, ensure there is no unburned fuel being pushed into the ash pan.

Storage

- Wood pellets should be left in their original sealed bag until ready to use, to prevent moisture.
- Shelled corn should be stored in a tightly sealed container to prevent moisture and to deter pests
- Do not store fuel within the specified clearance areas, or in a location that will interfere with routine cleaning and maintenance procedures.

CAUTION

Tested and approved for use with wood pellets and a mixture of shelled field corn and wood pellets ONLY. Burning of any other fuel will void your warranty.

NOTICE

Hearth & Home Technologies is not responsible for stove performance or extra maintenance required as a result of using fuel with higher ash or mineral content.

Tested & Listed By **OMNI-TEST** Portland Oregon USA
 Report #/Rapport #135-5-14c-6.2

Test to/Testé à ASTM E 1509-04, ULC-C1482-M91, AND ULC S627-00
 Tested by Emitech, Apave & BFP Electronique
 EN60335-1, EN55014-1, EN 61000-3-2, EN 14785:2005
 Test date: February 2004
 Room Heater Pellet Fuel Burning type (UM) 84-HUD

Model: XXV
 Residential Space Heating Appliance Fired by Wood Pellets
 This pellet burning appliance has been tested and listed for use in
 Manufactured Homes in accordance with OAR 814-23-900 through 814-23-909



Serial No.
 N° de série

008

"PREVENT HOUSE FIRES" Install and use only in accordance with manufacturer's installation and operation instructions. Contact local building or fire officials about restrictions and inspection in your area.

WARNING: FOR MANUFACTURED HOMES: Do not install appliance in a sleeping room. An outside combustion air inlet must be provided. The structural integrity of the manufactured home floor, ceiling and walls must be maintained.

Refer to manufacturer's instructions and local codes for precautions required for passing chimney through a combustible wall or ceiling. Inspect and clean exhaust venting system frequently in accordance with manufacturer's instructions.

Use a 3" or 4" diameter type "L" or "PL" venting system.
 Do not connect this unit to a chimney flue servicing another appliance.

FOR USE WITH PELLETIZED WOOD FUEL OR CORN/PELLET MIXTURE ONLY.
CONSULT MANUFACTURER'S INSTRUCTIONS.

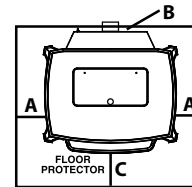
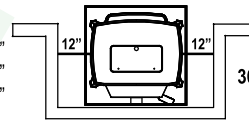
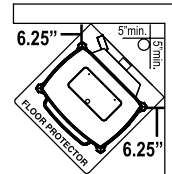
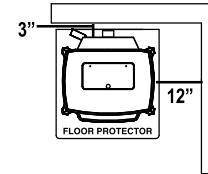
Input Rating Max: 5.7 lb. fuel/hr.
 Electrical Rating: 240 VAC, 50 Hz, Start 2.0 AMPS, Run 1.1 AMPS
 U.S. Electrical Rating: 115 VAC, 60 Hz, Start 4.1 AMPS, Run 1.1 AMPS
 Emission of CO in Combustion:
 Nominal Heat Output: .02%, Reduced Heat Output: .04%
 Flue Gas Temperature: 224 C
 Thermal Output: 10.5kW
 Energy Efficiency: Nominal: 84%, Reduced: 73%
 Fuel Type: Wood Pellets, 5mm diameter, 20mm long
 Route power cord away from unit.

DANGER: Risk of electrical shock. Disconnect power supply before servicing.
 Replace glass only with 5mm ceramic available from your distributor.
 For further instruction refer to owner's manual.
 Keep viewing and ash removal doors tightly closed during operation.

CLEARANCES TO COMBUSTIBLES

Back Wall to Appliance 3"
 Side Wall to Appliance 12"
Corner Installation
 Walls to Appliance 6.25"

Use a non-combustible floor protector extending at least 6 inches beyond the sides, front and back of unit as shown in Floor Protection Diagram. Measure from the top surface of the glass door.
 Recommended: Non-combustible floor protector with a minimum thickness of 1/2" with the fluepipe when installed with horizontal venting or under the top of a window opening.
 Do not remove this label.



This model is exempt from EPA certification under 40 CFR 60.531 by definition [Wood Heater (A) "Air-to-Fuel Ratio").

Modèle: XY
Appareil de chauffage à granulés
 Tests réalisés par OMNI TEST
 Essais selon les normes 15000-1-2, EN 61000-3-2, EN 14785:2005, EN 55014-1, EN 55014-2, EN 61000-3-3
NORMES EUROPEENNES
 NF EN 14785 CETIAT - AEMC MESURES EN - EMITECH, APAVE & BFP Electronique
 Respecter scrupuleusement les instructions du constructeur pour l'installation et les consignes de fonctionnement. Respecter les règles de sécurité en vigueur dans votre région.
AVERTISSEMENT POUR MOBILE HOMES : Ne pas installer dans une chambre. Il est impératif de prévoir une prise d'air extérieur. L'intégrité structurelle du plancher, du plafond et des murs doit être strictement préservée.
 Se reporter aux instructions du fabricant et aux réglementations spécifiques locales concernant les précautions requises lors de la traversée d'un mur ou d'un plafond. Contrôler et nettoyer fréquemment tout le système d'évacuation des fumées conformément aux recommandations du constructeur.
 Utiliser des conduits « Spécial granulés » de diamètre 80 mm ou 100 mm. Ne pas raccorder ce poêle à un conduit de cheminée déjà utilisé pour un autre appareil de chauffage.
FONCTIONNE EXCLUSIVEMENT AVEC DES GRANULES DE BOIS.
SE CONFORMER AUX INSTRUCTIONS D'UTILISATION
 Consommation maximale: 2,9 kg/h
 Caractéristiques électriques: 240 VC, 50 Hz, Intensité au démarrage 2 A, Intensité fonctionnement normal 1,1 A
 Tenir le cordon d'alimentation à l'écart du poêle.

DANGER : Risque d'électrocution. Débrancher l'appareil avant toute intervention.
 Ne remplacer la vitre qu'avec une vitre céramique de 5 mm de même qualité disponible auprès de votre revendeur.
 Pour une information plus complète, se reporter à la notice d'utilisation. Tenir la porte frontale et le couvercle de trémie hermétiquement clos durant le fonctionnement de l'appareil.
Puissance calorifique émise: Nominale: 10,5 Kw Réduite: 1,8 Kw
Concentration CO (à 13 % O2)
 à puissance nominale : 0,02 % à puissance réduite : 0,04 %
Rendement: à puissance nominale : 84 % à puissance réduite : 73 %
DISTANCES DE SECURITE PAR RAPPORT AUX MATERIAUX COMBUSTIBLES
 Entre mur arrière et appareil 8 cm
 Entre paroi latérale et appareil 31 cm
Installation en angle
 Entre murs et appareil 16 cm
Installation en alcôve
 Hauteur minimale de l'alcôve 150 cm
 Parois latérales de l'alcôve 31 cm
 Profondeur maximale de l'alcôve 91 cm
PROTECTION DU PANCHER:

	EU	CANADA
Côtés (A)*	6"/15cm	8"/20cm
Arrière (B)	0"	0"
Avant (C)*	6"/15cm	18"/46cm

 * mesurer à partir de la surface de la porte en verre.
 Utiliser une protection de sol non combustible sous l'appareil qui s'étend sur les côtés, l'avant et l'arrière du poêle (voir schéma). Il est recommandé que la protection s'étende jusque sous le conduit en cas d'installation d'un conduit horizontal ou sous le té en cas de conduit vertical.



AGENCE AMÉRICAINE POUR LA PROTECTION DE L'ENVIRONNEMENT
 Ce modèle est dispensé par EPA certification d'après 40 CFR 60.531 par définition [Appareil à bois(A) Ratio air/combustion]

Date of Manufacture/Date de Fabrication:
 2010 2011 2012 JAN FEB MAR APR MAY JUN JUL AUG SEPT OCT NOV DEC
 Ne pas enlever cette étiquette. Fabriqué aux USA

Harman Home Heating- 352 Mountain House Road - Halifax, PA 17032

IGN

Introduction

Thank you for purchasing the Harman XXV Pellet Stove. The Harman XXV Pellet Stove is the culmination of elegance, convenience, functionality and dependability

The XXV was thoughtfully designed to look captivating in every home. Intricately detailed oak leaves express the magnitude of craftsmanship that goes into making this stove a masterpiece. These beautiful castings are proudly made in the U.S.A.

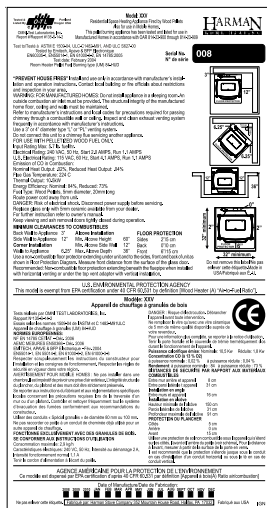
Built to strict Harman standards, the XXV has the most advanced construction of any Harman Pellet Stove. This 25th Anniversary Stove is based on Harman's patented pellet stove technology and goes a few steps further. The glass hopper lid allows you to see the fuel level while the mirrored front glass transforms into clear glass with the radiance of the fire.

A new concept for the XXV is the ability to use the top vent option. Using this method, the XXV can easily replace a wood stove by placing the top vent adapter over the rear vent.

We put all of our favorite features into the XXV, fusing the highest caliber pellet stove innovations with the allure of cast iron.



Serial #:



This label is located on the back of the unit. Please copy the Serial Number for future reference.

Table of Contents

Assembly & Installation	6
Installation	7
Venting	8
ESP Control	16
Low Draft Voltage Adjustment	17
Automatic Operation	18
Manual Operation	21
Room Sensor	23
Maintenance	24
Options	28
Trouble Shooting	29
Specifications	30
Wiring Diagram	30
Power Failure / Back-up	31
Warranty	32
Corn Burning Info	34
Service Parts List	35

Appliance Certification.

Model: XXV

Test Lab: Omni-Test Laboratories

Type: Pellet Burning Room Heater

Standard(s): ASTM E1509-04, ULC S627 and ULC C1482-M91. In accordance with OAR 814-23-900 through 814-23-909

Note: This appliance is also approved for installation into a shop.

Harman Home Heating
352 Mountain House Road
Halifax, PA 17032

IMPORTANT NOTES

Fuel should be stored in a cool dry place, well away from the room heater. Do not store fuel within the installation clearance area or the space required for loading and/or ash removal.

DO NOT use makeshift parts or other compromises when installing this appliance.

DO NOT INSTALL A FLUE DAMPER IN THE EXHAUST VENTING SYSTEM OF THIS UNIT.

DO NOT CONNECT THIS UNIT TO A CHIMNEY FLUE SERVING ANOTHER APPLIANCE.

DO NOT CONNECT THIS APPLIANCE TO ANY AIR DISTRIBUTION DUCT OR SYSTEM.

CAUTION

HOT WHILE IN OPERATION. KEEP CHILDREN, CLOTHING AND FURNITURE AWAY. CONTACT MAY CAUSE SKIN BURNS.

CAUTION

KEEP COMBUSTIBLE MATERIALS (SUCH AS GRASS, LEAVES, ETC.) AT LEAST 3 FEET AWAY FROM THE FLUE OUTLET ON THE OUTSIDE OF THE BUILDING.

Due to high temperatures, the stove should be placed out of traffic and away from furniture and draperies.

Children and adults should be alerted to the hazards of high surface temperatures and should stay away to avoid burns to skin and/or clothing.

Young children should be carefully supervised when they are in the same room as the stove.

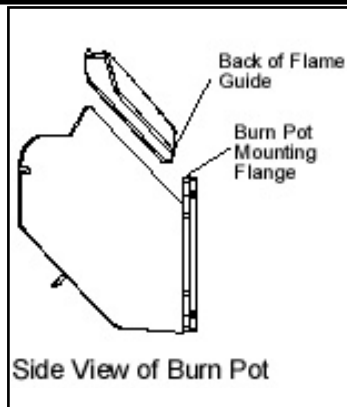
Clothing and other flammable materials should not be placed on or near this unit.

Installation and repair of this Harman stove should be done by a qualified service person. We recommend that the stove be inspected before use and at least annually by a qualified service person. Periodic cleaning is required throughout the heating season and at the end of each winter for the stove to work efficiently. See cleaning instructions.

Assembly and Installation

Flame Guide

Install the cast iron flame guide on top of the burn pot. Make sure that the flame guide is fully seated on the vertical sides of the burn pot and that the back of the guide rests against the burn pot mounting flange.



Install the venting only at the clearances specified by the venting manufacturer. Some brands of pellet venting require a 3" clearance to combustibles, while other brands may require only one inch.

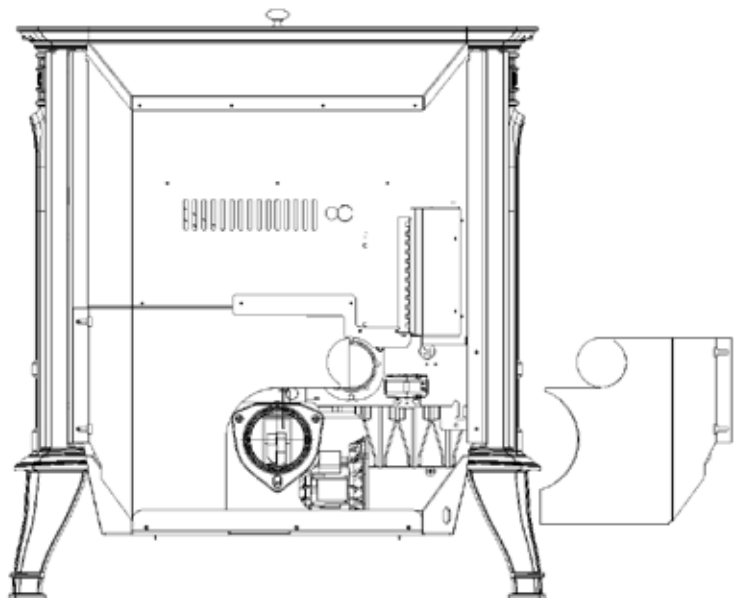


Figure 1

The power cord is tucked inside the left rear cover panel. To remove cord, Loosen the two 5/16" hex heads and slide the panel outward.

Installation

Installing

Place the stove on a non-combustible floor protector that extends a minimum of 6 inches (152mm) to the front (152mm), 6 inches to the sides (152mm) and flush with the rear of the hopper. Front and side floor protection measurements are made from the firebox or window opening. Floor protection must also be positioned under horizontal flue pipe. The minimum floor protector material is 20 gauge sheet metal. Other floor protector materials are ceramic tile, stone, brick, etc.

Place the stove away from combustible walls at least as far as shown in Figures 2 and 3.

Note that the clearances shown are minimum for safety but do not leave much room for access when cleaning or servicing. Please take this into account when placing the stove.

Connect the power cord to a 120 V.A.C. 60Hz grounded receptacle. (A surge protector is recommended to protect the circuit board.) Also be sure that the polarity of the outlet that the stove is plugged into is correct.

Prior to installing the flue pipe, connect a draft meter. (The draft meter must have a minimum range of 0-.5.) Record the first reading. Connect flue pipe to stove and be sure all doors and windows in the home are closed. Record the second draft reading _____. If the second reading is more than .05" lower than the first reading, check for possible restrictions or the need for outside air (see page 10). For more information on the draft test procedure, refer to Page 17.

Mobile Home Installation

When installing this unit in a mobile home several requirements must be followed (Reference HUD Regulation #24CFR3280):

1. The unit must be bolted to the floor. This can be done by using clips (part # 2-00-677110B) and 1/4" lag screws.
2. The unit must also be connected to outside air. See page 10.
3. Floor protection and clearances must be followed as shown.
4. Unit must be grounded to the metal frame of the mobile home.

CAUTION: This appliance must be vented to the outside.

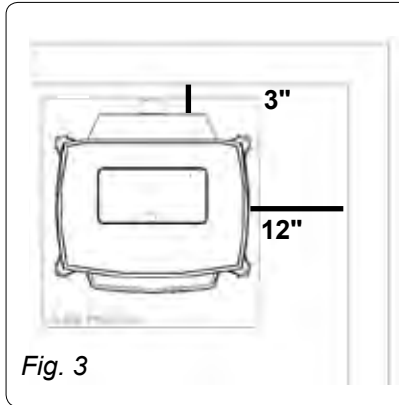


Fig. 3

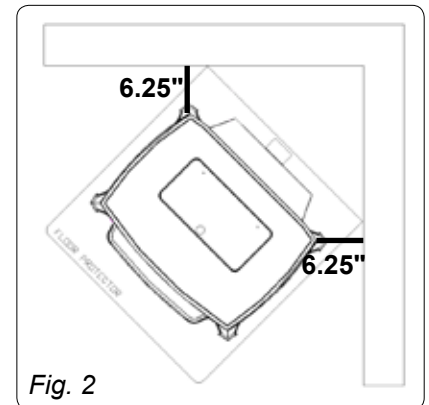


Fig. 2

Floor Protector minimum: 32" X 32"
(813mm X 813mm)

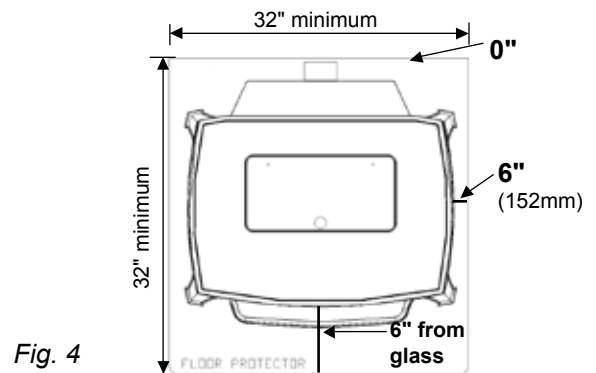


Fig. 4

*Measure front and side floor protection from the glass opening.

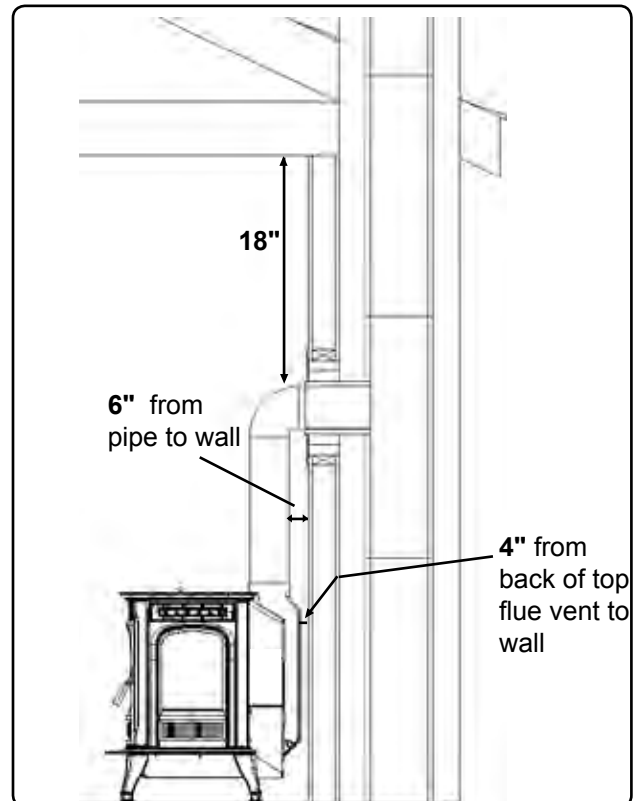


Fig. 5: Optional Top Vent Pipe Clearances

CAUTION
THE STRUCTURAL INTEGRITY OF THE
MOBILE HOME FLOOR, WALL, AND CEILING/
ROOF MUST BE MAINTAINED.

WARNING
Mobile home regulations do not allow
installation in a room designated for sleeping.

Venting

Requirements for Terminating the Venting

WARNING: Venting terminals must not be recessed into a wall or siding.

NOTE: Only the Harman Direct Vent Wall Pass-through (part # 1-00-677077) or PL listed vent pipe wall pass-throughs and fire stops should be used when venting through combustible materials.

NOTE: Always take into consideration the effects of the prevailing wind direction or other wind currents that may cause flyash and/or smoke when placing the termination vent.

In addition, the following must be observed:

A. The clearance above grade must be a minimum of 18".¹

B. The clearance to a window or door that may be opened must be a minimum of 48" to the side, 48" below the window/door, and 12" above the window/door.¹(with outside air installed, 18" to side or below window/door)

C. A 12" clearance to a permanently closed window is recommended to prevent condensation on the window.

D. The vertical clearance to a ventilated soffit located above the terminal within a horizontal distance of 2 feet (60 cm) from the center-line of the terminal must be a minimum of 18".

E. The clearance to an unventilated soffit must be a minimum of 12".

F. The clearance to an outside corner is 11" from center of pipe.

G. The clearance to an inside corner is 12".

H. A vent must not be installed within 3 feet (90 cm) above a gas meter/regulator assembly when measured from the horizontal center-line of the regulator.¹

I. The clearance to service regulator vent outlet must be a minimum of 6 feet.¹

J. The clearance to a non-mechanical air supply inlet to the building or the combustion air inlet to any other appliance must be a minimum of 48".¹

K. The clearance to a mechanical air supply inlet must be a minimum of 10 feet.¹

(with outside air installed, 6 feet)

L. The clearance above a paved sidewalk or a paved driveway located on public property must be a minimum of 7 feet.^{1,2}

M. The clearance under a veranda, porch, deck or balcony must be a minimum of 12 inches.^{1,3}**(B. Also Applies)**

NOTE: The clearance to vegetation and other exterior combustibles such as mulch is 36" as measured from the center of the outlet or cap. This 36" radius continues to grade or a minimum of 7 feet below the outlet.

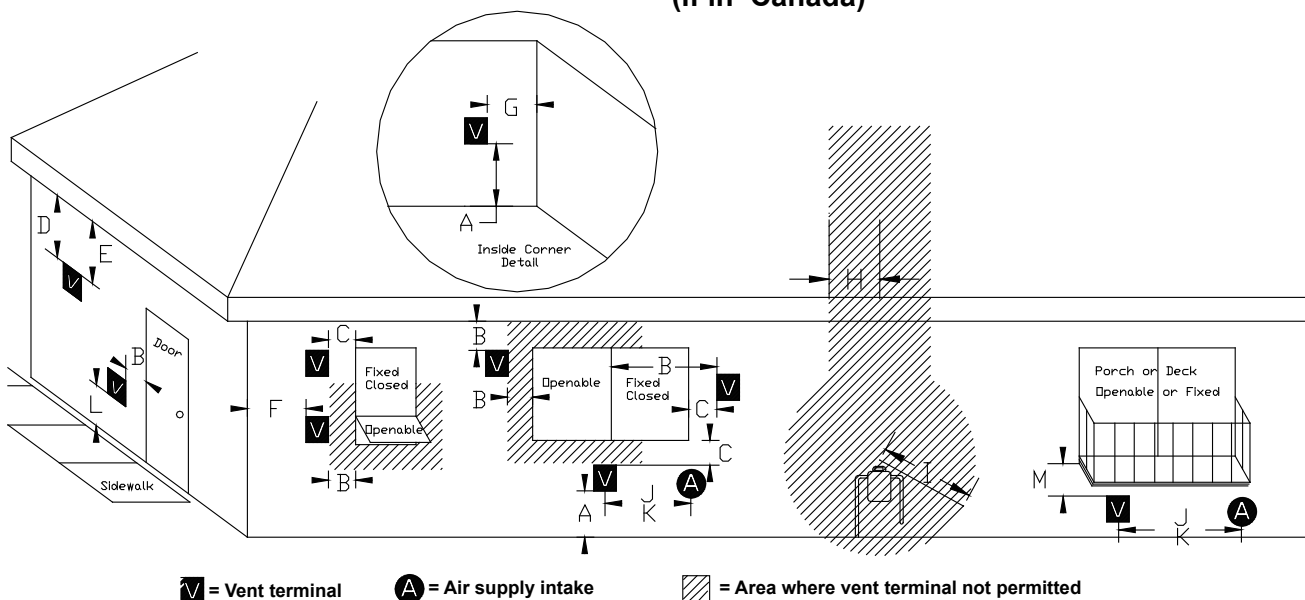
¹Certain Canadian and or Local codes or regulations may require different clearances.

²A vent shall not terminate directly above a sidewalk or paved driveway which is located between two single family dwellings and serves both dwellings.

³Only permitted if veranda, porch, deck, or balcony is fully open on a minimum of 2 sides beneath the floor.

NOTE: A chimney connector may not pass through an attic or roof space, closet or similar concealed space, floor, or ceiling.

NOTE: Where passage through a wall, or partition of combustible construction is desired, the installation shall conform to CAN/CSA-B365. (if in Canada)



Venting

IMPORTANT NOTICE

Approved Pellet Vent Pipe Must Be Used unless installing with the optional top 6" Flue Adapter. If using 6" Flue Adapter, it is recommended to use a sealed seam 6" flue pipe (snaplock seam is not recommended) secure each joint with at least 3 screws, and seal with high temperature silicone.

In some cases it may be necessary to use a liner in the existing chimney to obtain proper draft.

CAUTION

Do not connect to any air distribution duct or system.

Venting

A combustion blower is used to extract the combustion gases from the firebox. This causes a negative pressure in the firebox and a positive pressure in the venting system as shown in Fig. 6. The longer the vent pipe and more elbows used in the system, the greater the flow resistance. Because of these facts we recommend using as few elbows as possible and 15 feet or less of vent pipe. The maximum horizontal run should not exceed 48". If more than 15 feet of pipe is needed, the interior diameter should be increased from 3" to 4" because a larger pipe causes less flow resistance. **Be sure to use approved pellet vent pipe wall and ceiling pass-through fittings to go through combustible walls and ceilings.** The use of a starting collar is not always necessary. The first piece of pellet vent pipe must be fastened to the appliance flue collar with at least 2 fasteners. The two fasteners provided are a self-drilling type, however, due to material thickness, drilling a 3/32" pilot hole for each screw is recommended.

Vent Pipe

Pellet venting pipe (Known as "L" or "PL" venting) is constructed of two layers with air space between the layers. This air space is an insulator which reduces the surface temperature and allows a clearance to combustibles of 3 inches or less. The sections of pipe lock together to form an air tight seal in most cases. However, in some cases a perfect seal is not achieved. For this reason and the fact that the XXV operates with a positive vent pressure we specify that the **joints also be sealed with silicone.** Aluminum tape can also be used for any joint that is 1 ft. or more from the outlet of the stove.

When using the top vent option, 6 inch single wall pipe must be connected with at least three (3) screws at each joint. Also, the joints must be sealed with high temperature silicone.

We cannot emphasize enough, the importance of sealing every seam and joint in the venting system which is inside the home. Even the smallest pin hole can leak and when it does you will smell wood smoke or a creosote smell in the room. If this occurs check for leaks. Leaks are easiest to see during start-up. Alternatively you can use a smoke pellet to leak test the venting before lighting your first fire.

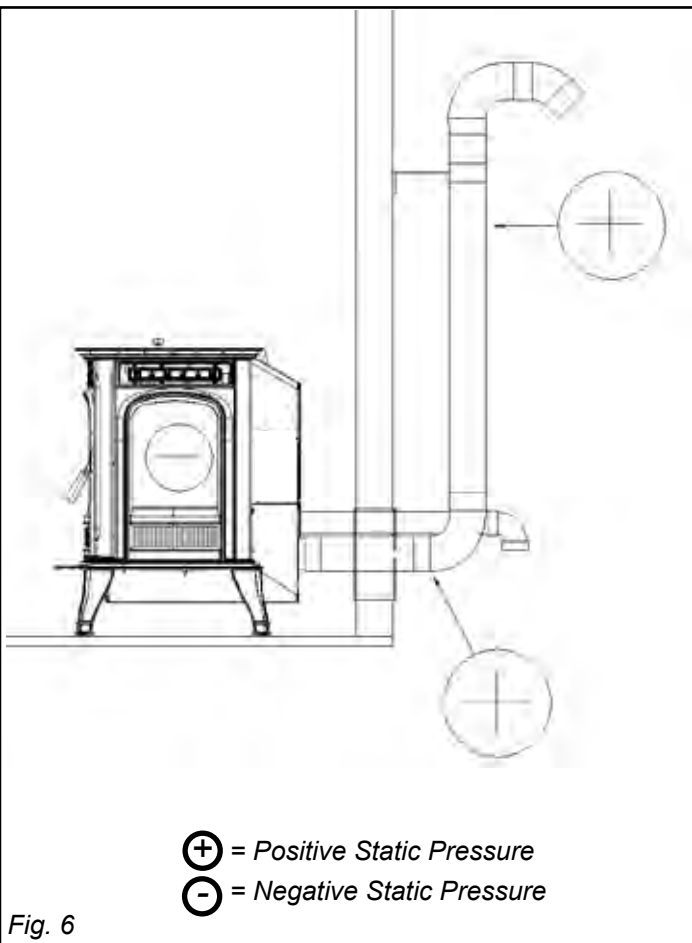
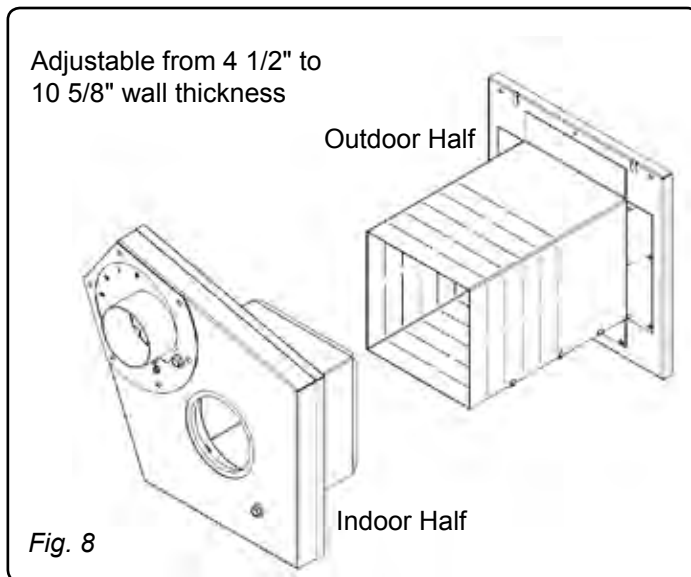
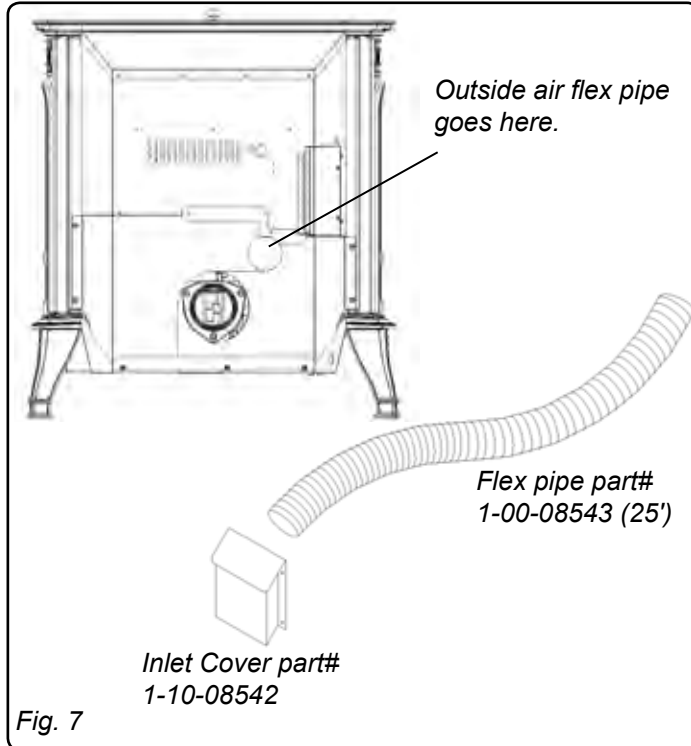


Fig. 6

INSTALL VENT AT CLEARANCES SPECIFIED BY THE VENT MANUFACTURER.

Venting



Direct Vent Wall Passthrough

The Harman Direct Vent Wall Passthrough (Part # 1-00-677077) makes installing your Harman Pellet Stove with outside air easier. It combines the needed wall protection for the venting, with a source of intake air for combustion. It is made to fit walls from 4 1/2" to 10 1/8" thick with a single square opening in the wall of 6-1/2 inches.

Avoiding Smoke and Odors

Negative Pressure, Shut-down, and Power Failure:

To reduce the probability of back-drafting or burn-back in the pellet burning appliance during power failure or shut-down conditions, the stove must be able to draft naturally without exhaust blower operation. Negative pressure in the house will resist this natural draft if not accounted for in the pellet appliance installation.

Heat rises in the house and leaks out at upper levels. This air must be replaced with cold air from outdoors, which flows into lower levels of the house. Vents and chimneys into basements and lower levels of the house can become the conduit for air supply, and reverse under these conditions.

Outside Air:

Harman Home Heating and Hearth & Home Technologies strongly recommend attaching outside air in all installations, especially lower level and main floor locations.

Per national building codes, consideration must be given to combustion air supply to all combustion appliances. Failure to supply adequate combustion air for all appliance demands, may lead to back-drafting of those and other appliances.

When the appliance is side-wall vented: The air intake is best located on the same exterior wall as the exhaust vent outlet and located lower on the wall than the exhaust vent outlet.

When the appliance is roof vented: The air intake is best located on the exterior wall oriented towards the prevailing wind direction during the heating season.

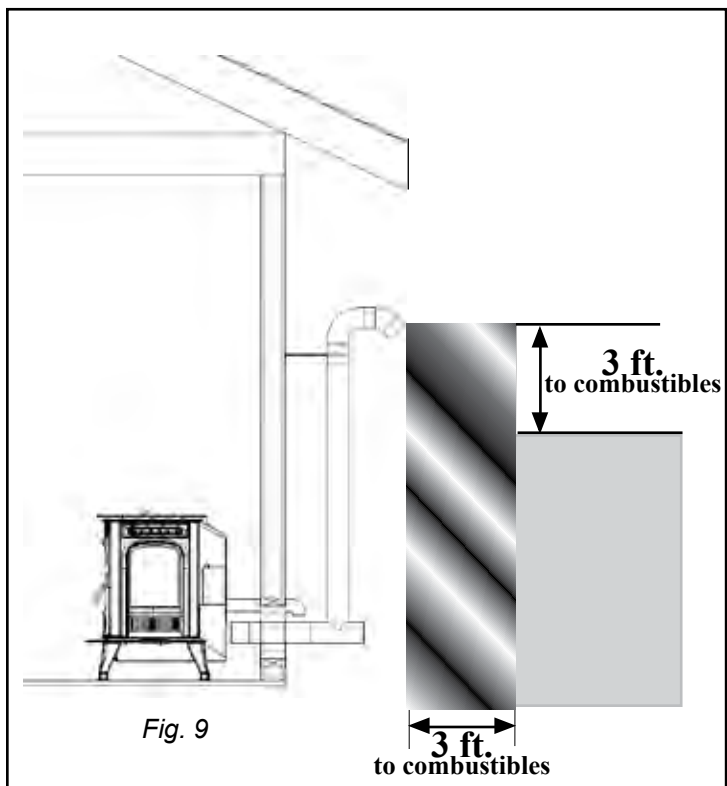
The outside air connection will supply the demands of the pellet appliance, but consideration must be given to the total house demand. House demand may consume some air needed for the stove, especially during a power failure. It may be necessary to add additional ventilation to the space in which the pellet appliance is located. Consult with your local HVAC professional to determine the ventilation demands for your house.

To install outside air use 2 3/8" I.D. non-combustible flex pipe. There is a break-away hole on the rear panel of the stove which must be removed to connect the flex pipe. The maximum length run of this pipe is 15 feet. If a longer run is needed the size must be increased to 3". Inlet cover part number 1-10-08542 should be used to keep birds, rodents, etc. out of the pipe unless the Harman wall passthrough is being used.

Venting

NOTICE

Use only components specified by the venting manufacturer or the appliance manufacturer, including the proper wall pass-through and termination cap. The use of mis-matched or makeshift venting components may cause exhaust spillage and/or increase fire risk.



#1 Preferred method

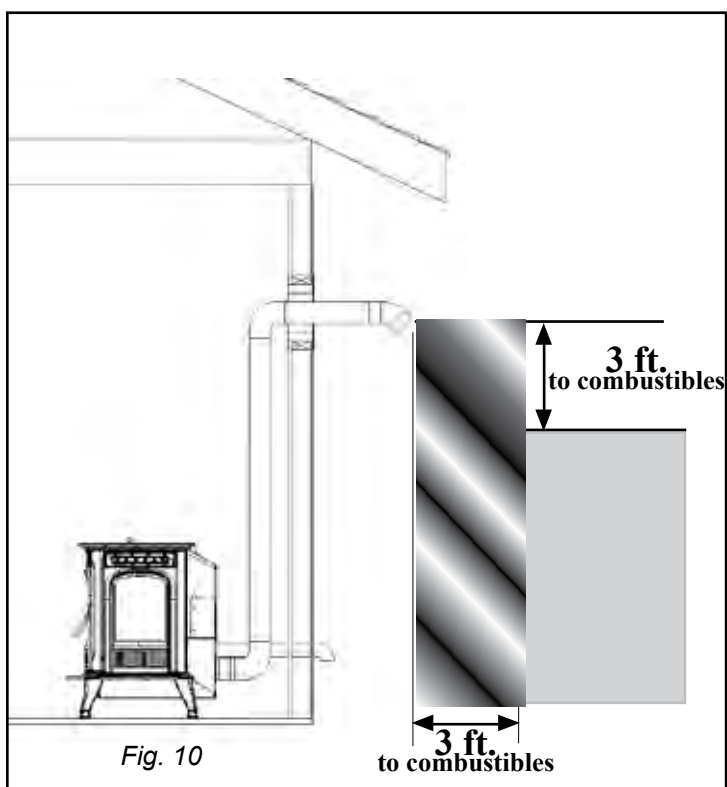
This method provides excellent venting for normal operation and allows the stove to be installed closest to the wall. Two inches from the wall is safe; however, four inches allows better access to remove the rear panel. The vertical portion of the vent should be three to five feet high. This vertical section will help provide natural draft in the event of a power failure. **Note: Do not place joints within wall pass-throughs.**

#2 Preferred method

This method also provides excellent venting for normal operation but requires the stove to be installed farther from the wall. The vertical portion of the vent should be three to five feet high and at least three inches from a combustible wall. This vertical section will provide natural draft in the event of a power failure.

If the stove is installed below grade be sure the vent termination is at least 18" above grade. The outlet must also be 1 foot from the house/building.

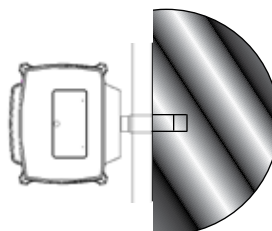
Note: Do not place joints within wall pass-throughs.



CAUTION

Keep any materials that may be affected by the elevated exhaust temperatures at least 3 feet away from the flue termination.

12" min. wall to outlet



Venting

#3 Installing into an existing chimney

This method provides excellent venting for normal operation. This method also provides natural draft in the event of a power failure. If the chimney condition is questionable* you may want to install a liner as in method #6.

*The chimney should be inspected and cleaned before installing your stove. If you discover that the chimney does not have a clay tile liner or has cracks or flaking of the tile liner you will need to install a stainless steel liner within the chimney. In most cases the inside diameter of this liner should be 4". Either flexible or rigid liner may be used for this purpose. Refer to Method 6.

Be sure to design the venting so that it can be easily cleaned.

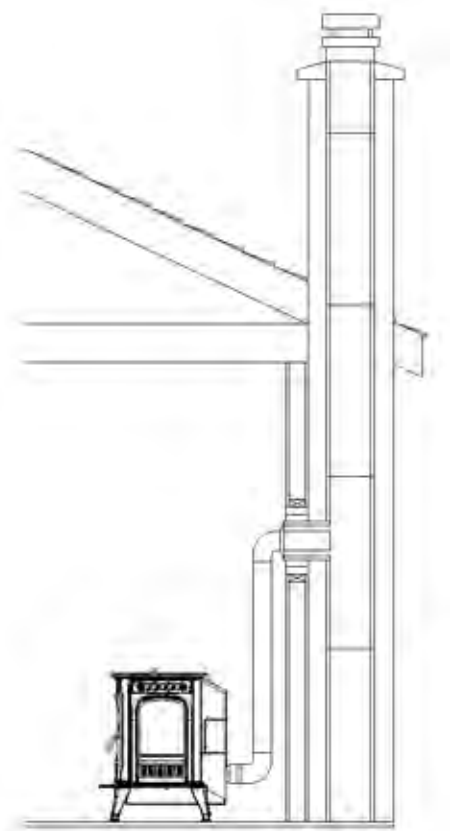


Fig. 12

#4 Installing into an existing chimney with optional top discharge 6" flue adapter

This method will allow single wall 6" flue pipe to come off the top of the stove and go directly into a masonry or class A chimney.

This method will be desirable for people who are replacing a wood or coal stove and have an existing chimney to use.

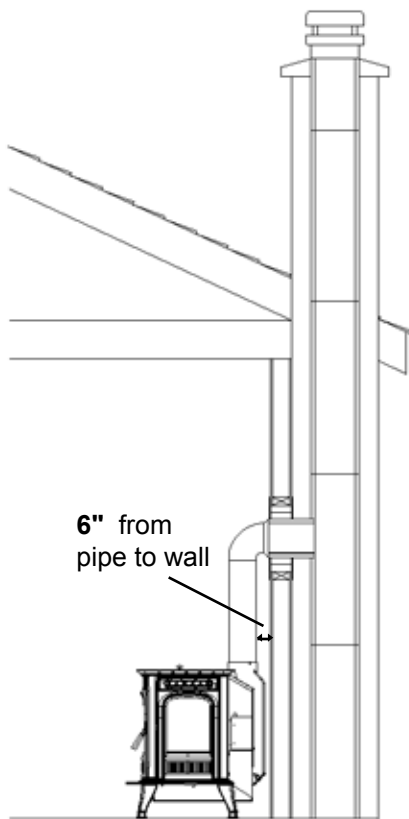


Fig. 13

Venting

#5 Installing into an existing fireplace chimney (US and Canada)

This method can be done with or without a flue liner. Without a liner, the damper area must be sealed off with a steel plate. Kaowool, mineral wool or an equivalent non-combustible insulation is recommended on top of the steel plate to minimize condensation. In this method a cap should also be installed on the chimney to keep out rain.

Some places in the US and Canada require that the vent pipe extend all the way to the top of the chimney. Per ULC S628.

Be sure to use approved pellet vent pipe fittings. Seal pipe joints with silicone or aluminum tape in addition to the sealing system used by the manufacturer. Pipe size should be increased to 4" using this method.

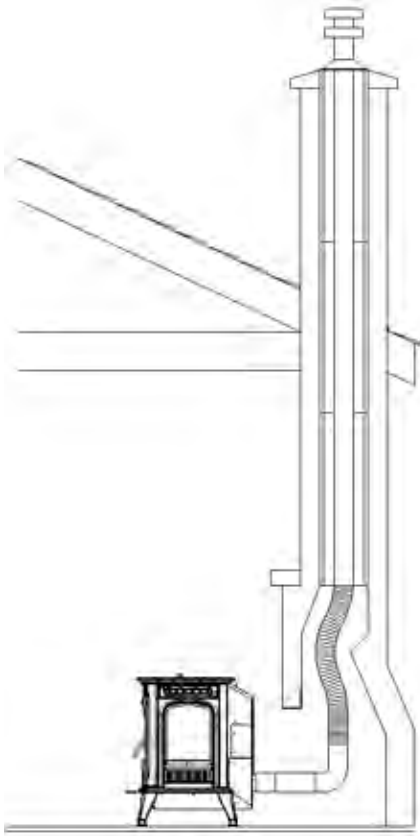


Fig. 14

#6 Installing into an existing chimney (US and Canada)

This method provides excellent venting for normal operation. This method also provides natural draft in the event of a power failure.

In this method a 4 inch liner is installed the entire length of the flue. Whether using a rigid or flexible liner, a cap should be installed on the chimney to keep out rain.

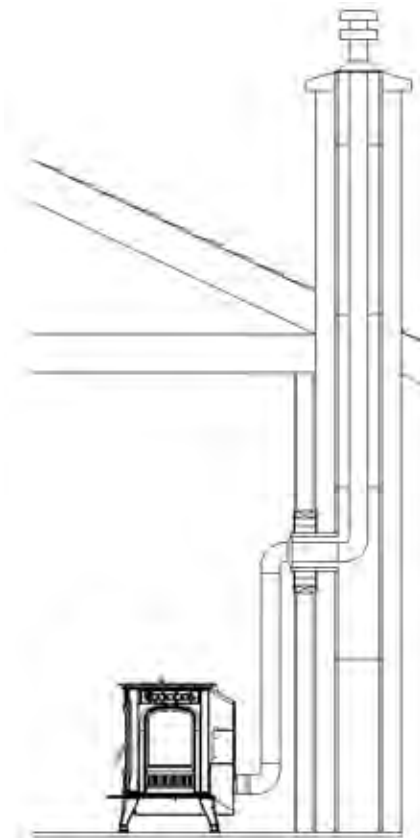


Fig. 15

Venting

#7 Installing into an existing chimney using 3" pellet vent in combination with 6" or 8" single or double wall stove pipe.

This method allows the installer to use 6" or 8" single and double wall stove pipe (sealed seam not snap lock) and an existing masonry or class A chimney to vent the stove.

The stove must use pellet vent and 90 degree elbow to start at the stove connector and then use the approved pipe adapter to connect to the size of vent that continues into the chimney connector. Support of the assembly must follow any pipe and connector manufacturers recommendations.

Due to combustible fuel, vent pipe to hopper clearances must meet guidelines stated by NFPA or local codes.

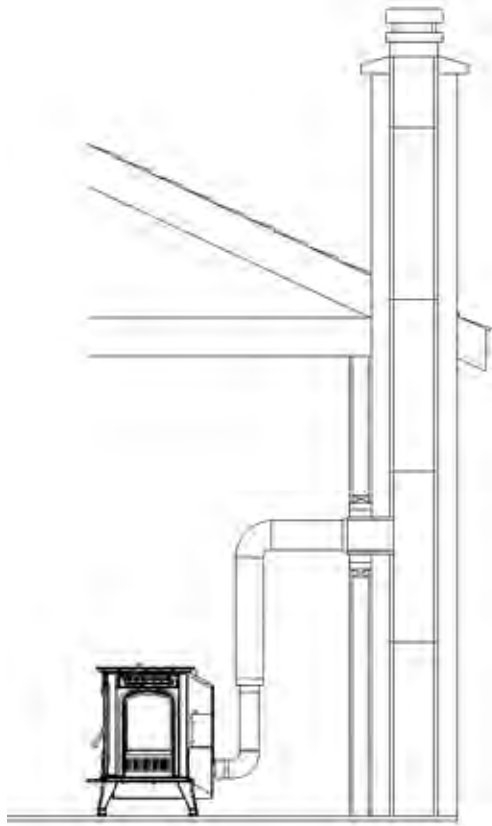


Fig. 16

#8 Installing through the ceiling

Through the ceiling vent, follow vent manufacturers recommendations when using a wall or ceiling pass through. **Note: Do not place joints within wall pass-throughs.**

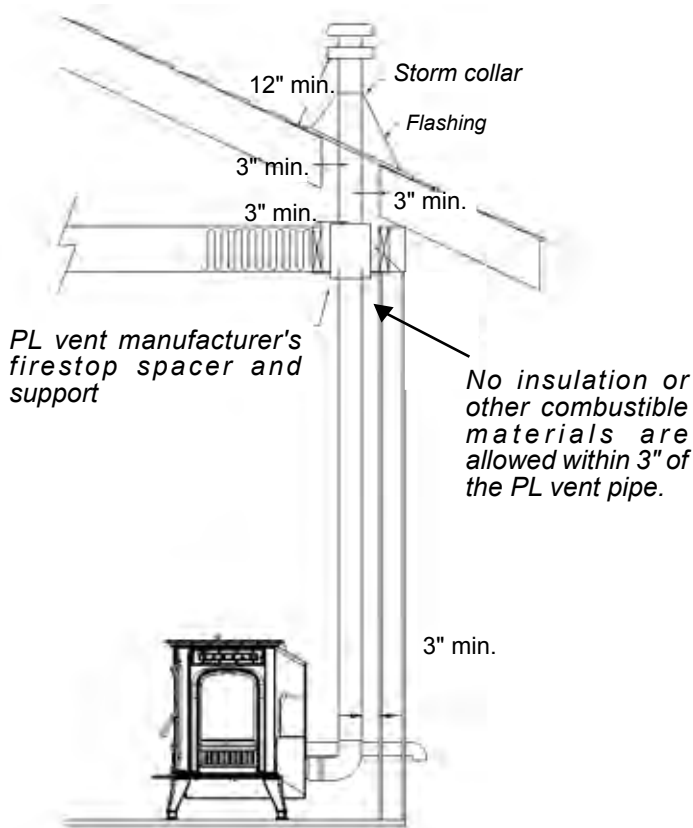


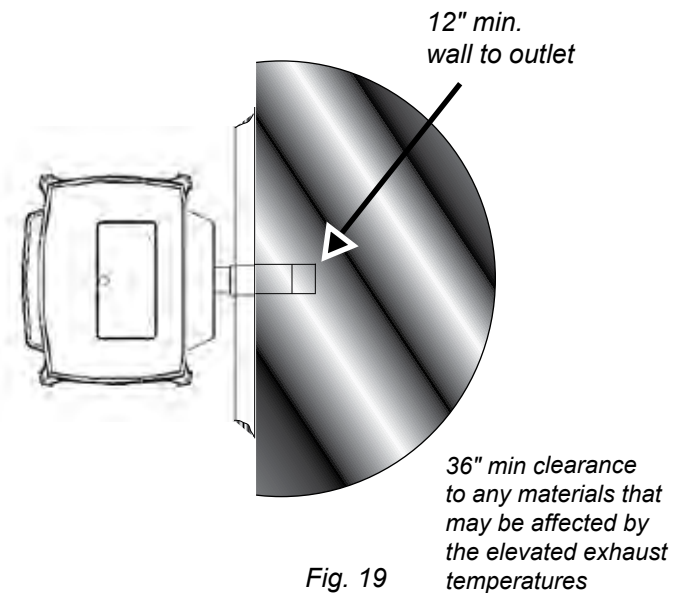
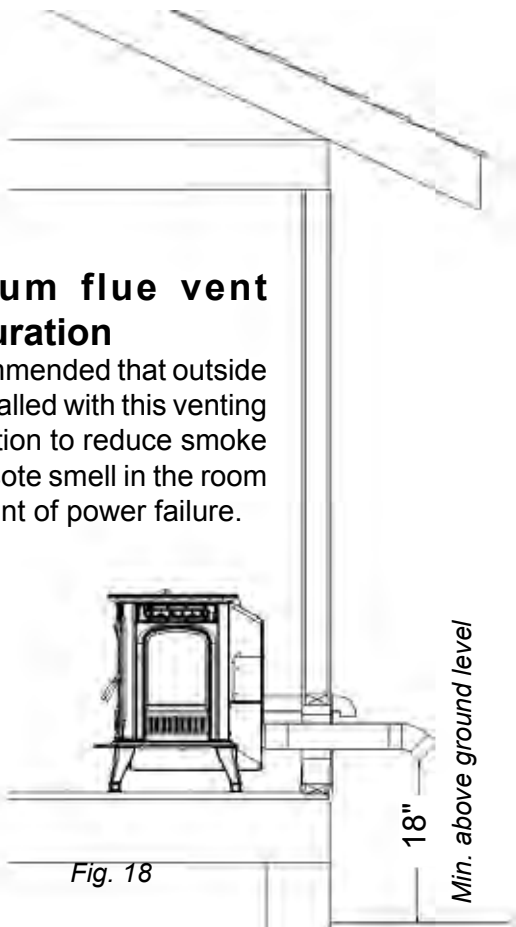
Fig. 17

WARNING:
THE CHIMNEY MUST BE OF A TYPE SUITABLE FOR SOLID FUEL BURNING. THE CHIMNEY AND CHIMNEY CONNECTOR MUST BE KEPT CLEAN AND MAINTAINED IN GOOD CONDITION.

Venting

Minimum flue vent configuration

It is recommended that outside air be installed with this venting configuration to reduce smoke and creosote smell in the room in the event of power failure.



Vent Configurations:

To reduce probability of reverse drafting during shut-down conditions, Hearth & Home Technologies strongly recommends:

- Installing the pellet vent with a minimum vertical run of five feet, preferably terminating above the roof line.
- Installing the outside air intake at least four feet below the vent termination.

To prevent soot damage to exterior walls of the house and to prevent re-entry of soot or ash into the house:

- Maintain specified clearances to windows, doors, and air inlets, including air conditioners.
- Vents should not be placed below ventilated soffits. Run the vent above the roof.
- Avoid venting into alcove locations.
- Vents should not terminate under overhangs, decks or onto covered porches.
- Maintain minimum clearance of 12 inches from the vent termination to the exterior wall. If you see deposits developing on the wall, you may need to extend this distance to accommodate your installation conditions.

Hearth & Home Technologies assumes no responsibility for, nor does the warranty extend to, smoke damage caused by reverse drafting of pellet appliances under shut-down or power failure conditions.

AUTOMATIC IGNITION ESP CONTROL

Dealer Diagnostic Port

For dealer maintenance only. Requires special DDM monitor supplied to Harman Dealers exclusively.

Distribution Blower speed adjustment range:

L = low
H = high

Variable speed anywhere between L and H; although as the stove temp. goes up, so does the low end of the scale.

Mode Selector

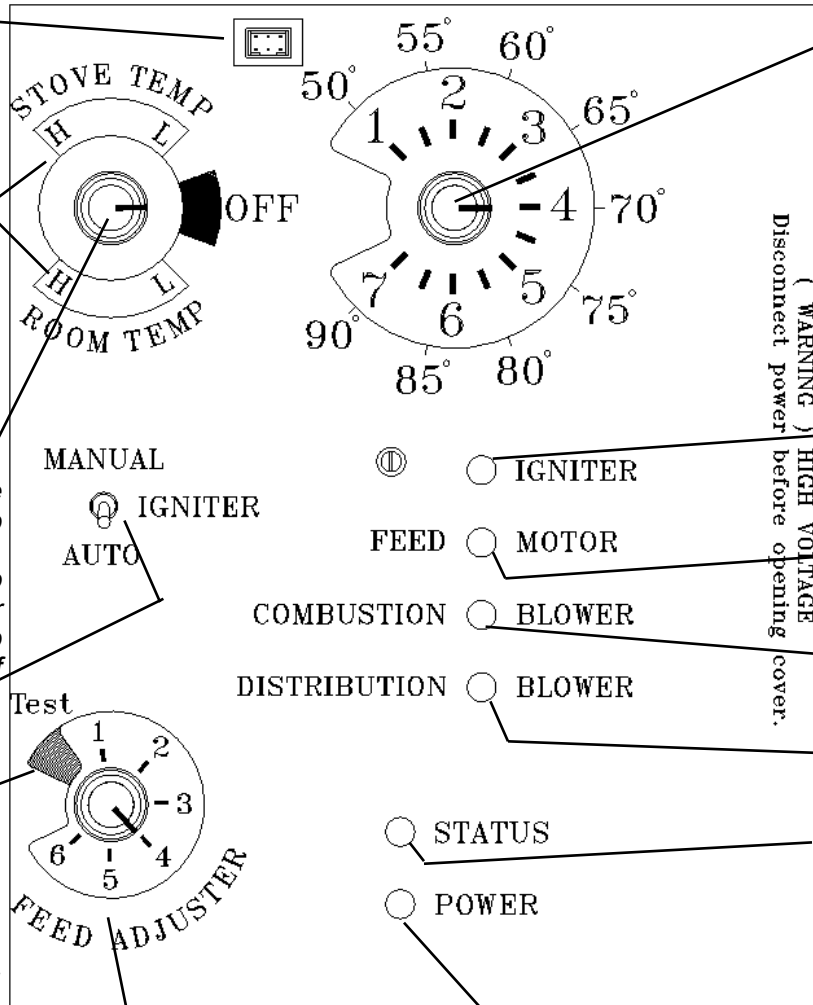
Allows you to choose between Room Temp Mode, Stove Temp Mode, or OFF. Also allows you to vary the distribution blower speed by turning the knob to the high or low side of each mode.

Igniter switch

Set to appropriate Start-Up mode.

Test

Runs all motors at full speed for one minute to check operation. Afterwards, the stove will be at minimum draft and will remain there as long as you are still in "Test Mode".



Feed adjuster
Sets the maximum feed rate per each cycle of the control.

Power Light
Indicates power to the control.

Temp dial

Allows you to adjust the room temperature in Room Temp Mode using the outer scale marked in degrees Fahrenheit. It also allows you to adjust the stove temperature while in Stove Temp Mode using the inner scale marked from 1 to 7.

Indicates power to the igniter

Indicates power to the feed motor.

Indicates power to combustion blower

Indicates power to distribution blower.

Status Light

Will be lit in either stove or room temp mode when pointer is not within off position band except after normal shut down. Blinks to indicate errors listed below.

Status light error messages:

3 Blinks: Indicates that the ESP (Exhaust Sensing Probe) has gone out of range too many times. If the stove seems to be operating correctly, perform a manual reset*. May indicate a need for cleaning, especially the exhaust / venting system.

4 Blinks: Can occur only in Room Temp Mode and indicates Room Sensing Probe failed or not installed. If a Room Sensing Probe is then installed, the status light will automatically reset.

5 Blinks (In Igniter Auto. Mode Only): Indicates that the unit has failed to light within the 36 minute start cycle. To reset - Turn Mode Selector to "OFF", then turn to either mode again.

6 Blinks : Indicates that the control has calculated poor or incomplete combustion occurring for more than 50 minutes.

A six blink status may be set if the stove is allowed to run out of pellets. To reset, turn mode selector to "OFF" then back on to the desired mode. If the unit was not out of pellets, see Troubleshooting section for more details.

* **Manual reset-** disconnect the power cord for a few seconds and reconnect. If error still occurs call your Dealer.

Low Draft Voltage Adjustment

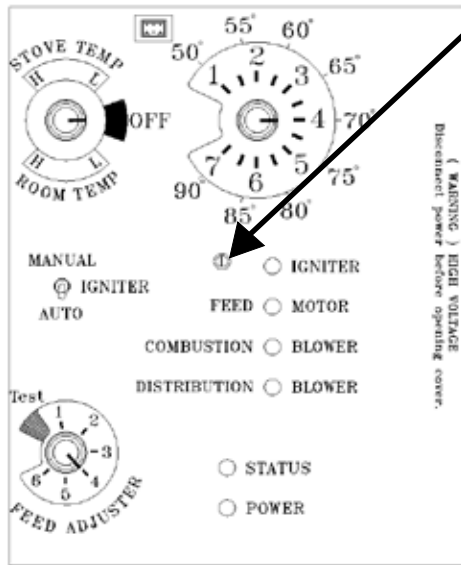


Fig.29

Combustion Motor Speed Control
Low draft only set point.
The small straight screwdriver slot is plastic; therefore, the unit can be adjusted while in operation.

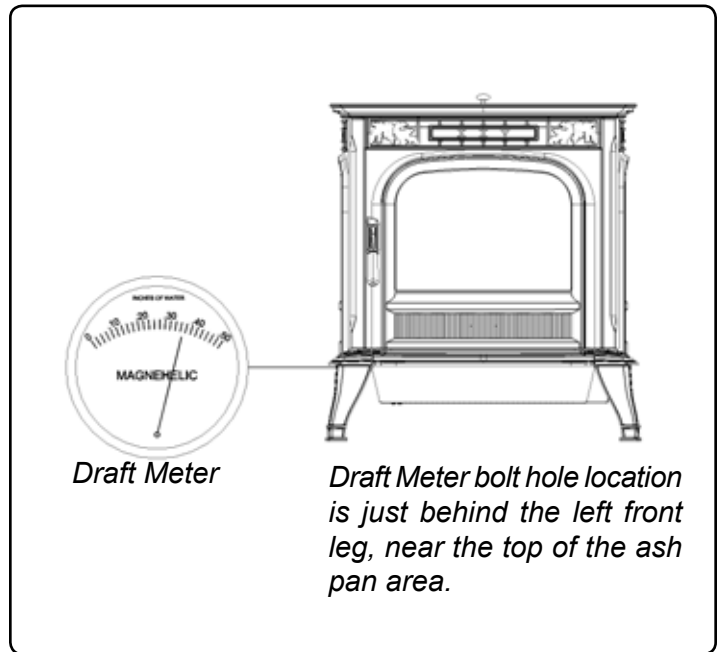


Fig.30

Low Draft Voltage Adjustment

These units are pre-tested at the factory with exactly 120 Volts A.C., 60 Hz. They are checked and adjusted for firebox tightness, gasket leakage, motor operation and igniter operation. The XXV is then factory set at a mid-point adjustment and in most cases will not need any adjustments. **NOTE: The factory low draft setting may not be correct for the unit's permanent installation conditions.**

The control board on the XXV is equipped with a low draft adjustment port. Located on the control face just to the left of the igniter light. This voltage adjustment is provided to allow the unit to be adjusted for the household voltage where the unit is going to be in permanent operation. **NOTE: The line voltage varies from area to area and often home to home.**

The low draft voltage should be adjusted to achieve the most efficient burn on low burn or "maintenance". This voltage adjustment allows the installer to change the low voltage set point approximately 10 volts. This adjustment should be done by the installer during set up because a draft meter reading is **required** to insure proper set up.

If the unit is not adjusted properly, it does not cause a safety concern. If the unit is adjusted too high, only efficiency is lost. If the unit is adjusted too low, the low draft pressure switch will not allow the feed motor or the igniter to operate.

A simple draft test should be performed after completing the flue pipe installation. To record the results for future reference:

1. Plug unit into a 120VAC, 60 HZ outlet.
2. Close the hopper lid, front view door, and the ash pan. Neither pellets or a fire are required for this test.
3. With the mode selector in the "OFF" position, turn the feed adjuster to "TEST".
4. Record the high draft ____ in W.C. (Normal is -.50 to -.60) The control will be on the High Draft for a total of 1 minute.
5. After 1 minute, the combustion motor will go down to low draft and the distribution blower will go on high. Allow approximately 15 seconds to pass for the combustion motor to slow before checking the low draft.
6. If the low draft is between -.35 and -.45, record the reading ____ in W.C. If the reading is higher, slowly turn the set screw counter-clockwise until the draft lowers. If the reading is lower, very slowly turn the set screw clockwise until the draft increases.

NOTE: In some cases, the draft may not go as low as -.35 to -.45 even with the set screw completely counter-clockwise, ideally, you should just set it as low as possible.

AUTOMATIC IGNITION/OPERATION

The XXV is a fully automatic stove that features two operating modes; **Stove Temperature Mode** and **Room Temperature Mode**. In Stove Temperature Mode, you select a burn rate and the stove will remain at the same burn rate regardless of the room temperature.

In the Room Temperature Mode the stove constantly monitors the temperature in the room and adjusts the size of the fire and the heat output of the stove so that the room is kept at a constant temperature. Room Temperature Mode, in the AUTO position, has the added advantage of turning the stove off if no heat is required and turning the stove on again when the room temperature drops below your desired room temperature set point.

Room Temperature Mode

Most consumers use the stove in the Room Temperature Mode because it is the easiest and most efficient method of keeping the room at a given temperature. In the Room Temperature Mode, the Room Sensing Probe constantly monitors room temperature. As the weather changes outside and your home needs varying amounts of heat to be at a desired temperature, the stove will automatically adjust size and heat output of the fire so that a constant even temperature is maintained. If the weather warms up and no heat is required the stove will gradually shut down. When the house cools down, the stove will automatically bring the room temperature to your desired setting.

In the Room Temperature Mode you can select either **Auto or Manual modes** for the **igniter** using the igniter toggle switch. When the toggle switch is in the Auto position the igniter, located inside the burn pot, is ready to automatically light the fire when required. When the toggle switch is set to the Manual position, the stove can be lit manually with either a gel or a wax type fire starter. (see lighting instructions on page 20.) With the igniter toggle switch set in the Manual position the stove will automatically adjust the heat output, but the stove will not automatically shut down if no heat is required. Instead it will go to its lowest setting and remain there. The Manual position on the igniter toggle switch lets you light the stove manually, should the igniter fail for any reason. Secondly, if you are using the Harman battery back up system the Manual setting will prevent the stove from turning off and on during a power failure, which will drain the back up battery, and possibly cause damage to the back-up or the stove.

In the Room Temperature Mode, the distribution blower speed can be increased or decreased by adjusting the Room Temp/Off/Stove Temp dial between L and H. As output of the stove increases, the speed of the blower will increase automatically to ensure that more heat is transferred out into the room. The distribution blower will shut off as the room reaches the set temperature, this will prevent overheating of the room.

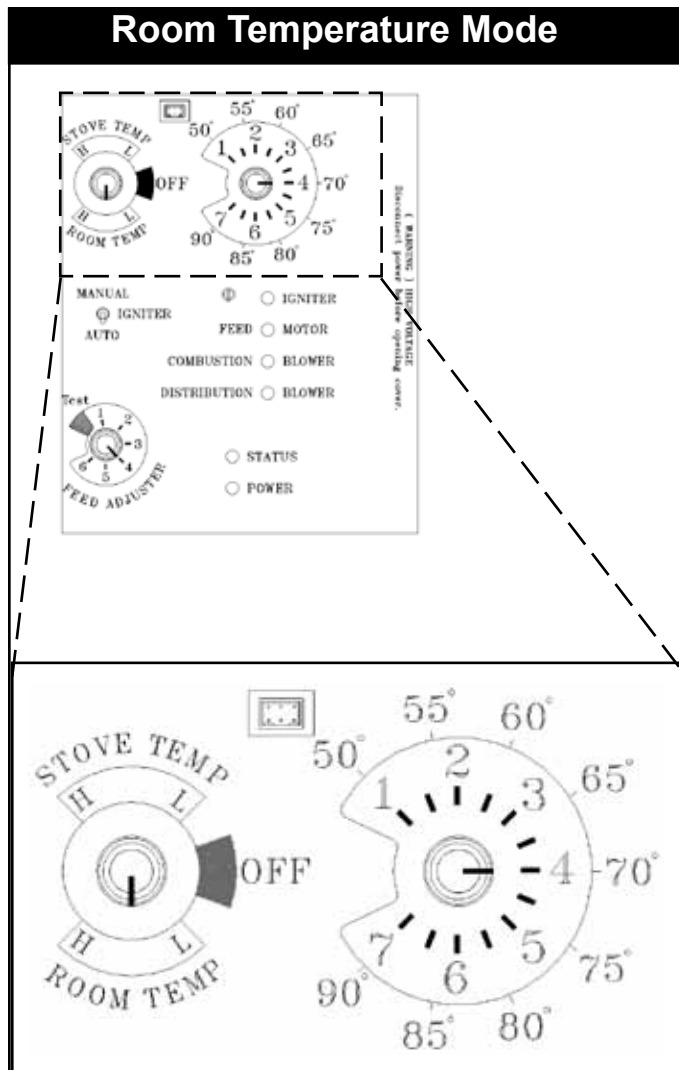


Fig. 20
Room Temperature Mode: This setting, see above, will produce a room temperature of 70 degrees with the distribution blower at medium speed.

Keep hopper lid, loading and ash removal doors closed at all times during operation.
Maintain gaskets and seals in good condition.

AUTOMATIC IGNITION/OPERATION

Stove Temperature Mode

In the Stove Temperature Mode and with the igniter toggle switch in the Auto position, the stove will light automatically and can be adjusted to the desired setting using the same temperature control dial as is used in the Room Temperature Mode. The heat output and fuel consumption will remain constant regardless of room temperature. The settings from 1 to 7 on the inner ring of the dial provide for relative heat output settings with 1 being low and 7 being the maximum.

In Stove Temperature Mode, the stove will not automatically shut off unless the stove runs out of fuel or is turned off.

Never disconnect the power cord to shut down the stove. This will stop the combustion blower and smoke will escape through window and door gaskets.

Feed Adjuster Knob

This knob controls the maximum amount of time per cycle that the feed motor is allowed to run. Based on the control settings and temperature demand, the control will make its own determination of how long to run the feed motor, **UP TO** the maximum allowed by the Feed Adjuster knob setting. For most premium grade pellet fuels, the feed adjuster should be set at #4. If high-ash fuel is used, the setting may need to be adjusted to #5 or 6. Higher settings are also needed if you want to achieve the maximum capacity of the stove. Just be sure that when burning at maximum, Stove temperature mode with the feed adjuster on #6 and the temperature knob on "7" or "90°", the pellets are not falling off the front of the burn pot before they have a chance to burn completely. You should try to keep about one inch of ash in front of the burning pellets.

Shut Down Procedure

The best way to shut down the stove is to simply let it run out of pellets, the stove will shut down automatically. Alternatively, you can turn the Mode Selector to "off". This will cause the fire to gradually die down and go out. The fire will not go out immediately and may take more than an hour to fully shut down.

If the stove is left to run out of fuel, you may get a 6 blink status light. If this happens simply reset the control board by turning the mode selector to OFF and back ON.

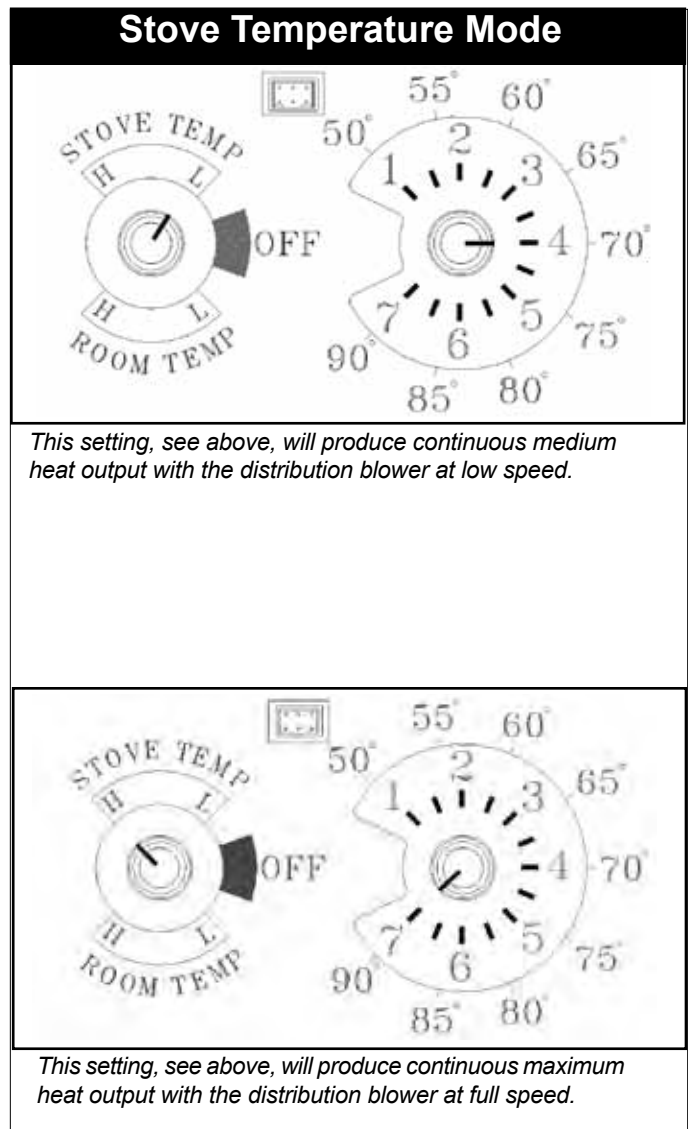


Fig. 21

AUTOMATIC START UP

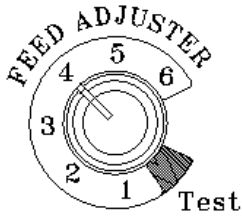


Fig. 22

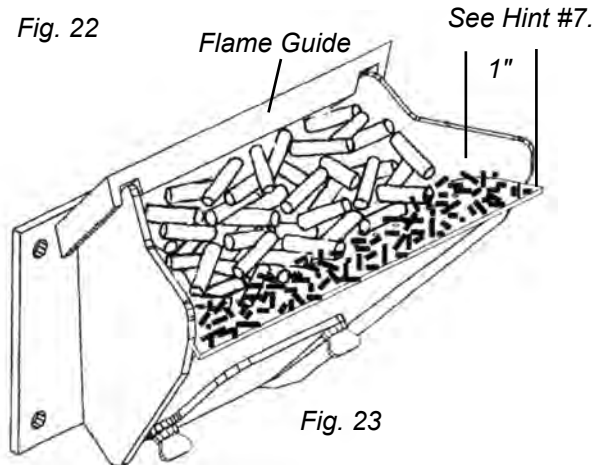


Fig. 23

Helpful Hints

1. Fines are small pieces of broken pellets (sawdust). Fines do not flow easily and often build up on the hopper funnel bottom angles. You can push these fines into the feeder opening and then fill the hopper with pellets. As the system works, they will be burned. Or you can clean them out before filling the hopper.
2. The "TEST" cycle will operate the feeder motor for exactly one minute. Turning to "TEST" again and again may purge too much fuel into the burn pot causing excessive smoke on start-up.
3. The firebox low pressure switch will not allow the auger motor or the igniter element to operate if the view door or the ash pan door are open.
4. Adjust Feed Rate. If this is your first fire or you are trying different pellets, set the feed adjuster to #4, Fig. 22. This is a conservative number and will probably need to be increased. After you know a feed rate setting that works well, use that setting. Remember, if your feed rate is too high you may waste fuel.
5. This is usually a weekly maintenance procedure. Cleaning the burn pot with the scraper with a small amount of new fuel in the bottom is not a problem. First, scrape the ashes off the front of the burn pot into the ash pan. Then, scrape the top surface of the burn pot downward into the base of the burn pot. When the stove is ignited these scrapings will be pushed out by the feeder and burned.
6. The ash pan can hold the ashes from approximately 1 ton of premium fuel. This means the ashes will only need to be emptied a few times a year.
7. Setting the feed adjuster # for maximum burn: With the unit burning in "AUTO", turn to "Stove Mode" and put the fan on "H". Set the Temperature Dial to #7. Allow the unit to burn for about 30 minutes and check ash on front of burn pot. Fig. 23. If the ash line is larger than 1", turn the feed adjuster from #4 to #5. Allow another 30 minutes of burn time and check again. If, at #6 setting, a 1" or less ash bed is not obtainable, it is not a problem. The 1" ash bed is only a maximum burn rate and at most normal settings the ash bed will be larger.

Starting Fire

Igniter Switch to "AUTO" (down position)

Make sure the unit is plugged into a 120 VAC, 60 HZ electrical source. The power light should be the only light lit.

To avoid unwanted smoke, be sure there is no fuel in the ash pan prior to lighting.

1. Turn Mode Selector to "OFF".
2. Fill hopper with pellets.¹
3. Clean burn pot with scraper, if necessary.⁵
4. If starting after an empty hopper, turn Feed Adjuster to "TEST" (for one 60 second cycle).² This will feed pellets into the auger tube and also allow you to check the motors for operation.
NOTE: The auger motor will not operate with the view door or ash pan door open.³
5. Turn Feed Adjuster to #4.⁴
6. Flip the Igniter Switch down into the "AUTO" position.
7. Turn the Temperature Dial to desired room temperature.
8. Turn Mode Selector to Room Temperature or Stove Temperature.
9. Fill hopper with pellets and remove ashes as required.⁶

WARNING

KEEP ALL DOORS AND HOPPER LID CLOSED DURING OPERATION.

WARNING

"NEVER USE GASOLINE, GASOLINE-TYPE LANTERN FUEL, KEROSENE, CHARCOAL LIGHTER FLUID, OR SIMILAR LIQUIDS TO START OR "FRESHEN UP " A FIRE IN THIS HEATER. KEEP ALL SUCH LIQUIDS WELL AWAY FROM THE HEATER WHILE IN USE".

WARNING

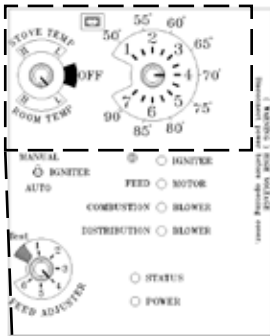
ONLY USE WOOD PELLET FUEL. DO NOT BURN GARBAGE IN STOVE.

MANUAL IGNITION/OPERATION

The XXV Pellet Stove is capable of manual operation. This also allows the operator to manually control operation during an emergency (i.e. igniter failure, or when using certain generators.)

The unit can be switched between "AUTO" and "MANUAL" at any time during operation.

Room Temperature Mode: This setting, see below, will produce a room temperature of 70 degrees with the distribution blower at medium speed.



NOTE: When starting the unit in "AUTO" mode and switching to "MANUAL": Once an ignition cycle has started, it will continue regardless of mode. Switching from "Auto" to "Manual" can be done as soon as the igniter light comes on.

Igniter Switch to "MANUAL" Room Temperature Mode

The fire will have to be lit with starting gel and a match, or started automatically, see "Automatic Operation" on Page 20. Turn to "Manual" position after the ignition cycle starts.

The difference between "AUTO" Room Temperature Mode and "Manual" Room Temperature Mode is that the fire will not go out as the room temperature goes above the control board setting. The unit can only go to low burn and will remain there until it runs out of fuel or until more heat is needed and the feed rate increases. Feed rate adjustments and dial settings are the same as "AUTO" settings. The blower will shut off completely if the temperature on the ESP is too low.

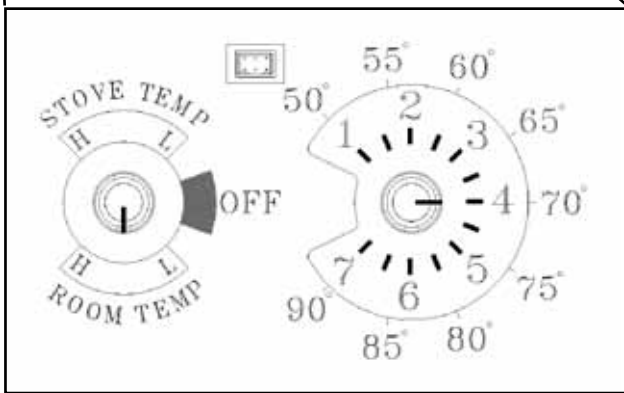


Fig. 24

Manual Stove Temperature Mode

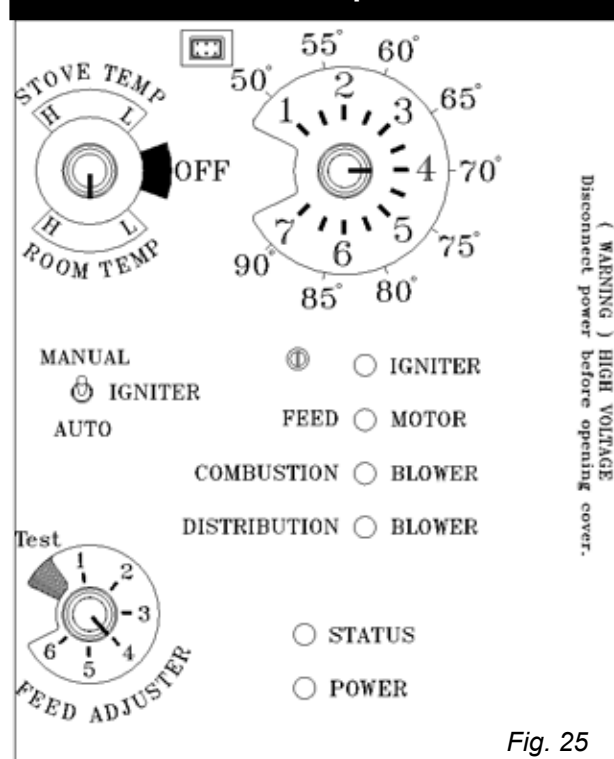


Fig. 25

This setting will produce a large viewing fire without a distribution blower operating.

Igniter Switch to "MANUAL" Stove Temperature Mode

The advantage of this mode is to allow the operator to have a large viewing fire without blowing extra heat into the room.

During operation, with the temperature dial set at #3 or less, the distribution fan will not operate. It is not necessary to operate the distribution blower below this point. This control setting allows a higher burn rate (a larger viewing fire) without an excess of hot air blowing into the room.

An example of when to use the Manual Stove Temperature Mode is if you want to watch a large fire and the room is already up to temperature. The Stove Temperature Mode allows you to have a larger fire and a lower sound level, without the distribution blower.

NOTE: During the use of this mode, if you keep increasing the temperature dial setting to increase the fire size, the distribution blower will automatically come on when the ESP Temperature reaches 350° F, or 81% output.

MANUAL START UP

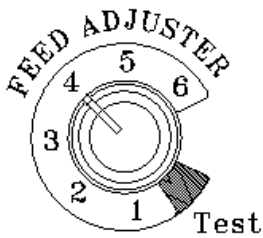


Fig. 26

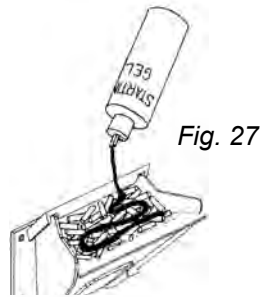


Fig. 27

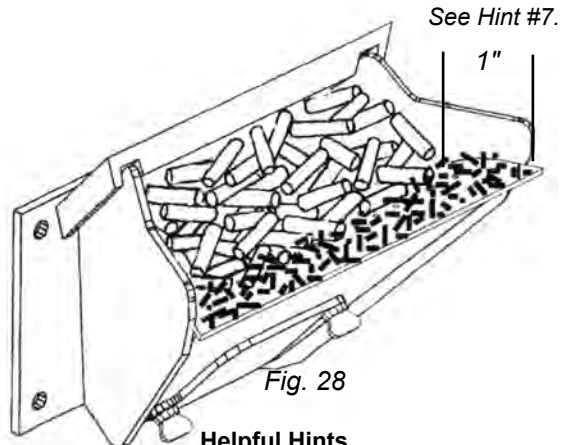


Fig. 28

Helpful Hints

1. Fines are small pieces of broken pellets (sawdust). Fines do not flow easily and often build up on the hopper funnel bottom angles. You can push these fines into the feeder opening and then fill the hopper with pellets. As the system works, they will be burned. Or you can clean them out before filling the hopper. As the system works, they will be burned.

2. The "TEST" cycle will operate the feeder motor for exactly one minute. Turning to "TEST" again and again may purge too much fuel into the burn pot causing excessive smoke on start-up.

3. The firebox low pressure switch will not allow the auger motor or the igniter element to operate if the view door or the ash pan door are open.

4. Adjust Feed Rate. If this is your first fire or you are trying different pellets, set the feed adjuster to #4, Fig. 26. This is a conservative number and will probably need to be increased. After you know a feed rate setting that works well, use that setting. Remember, if your feed rate is too high you may waste fuel.

5. This is usually a weekly maintenance procedure. Cleaning the burn pot with the scraper with a small amount of new fuel in the bottom is not a problem. First, scrape the ashes off the front of the burn pot into the ash pan. Then, scrape the top surface of the burn pot downward into the base of the burn pot. When the stove is ignited these scrapings will be pushed out by the feeder and burned.

6. The ash pan can hold the ashes from approximately 1 ton of premium fuel. This means the ashes will only need to be emptied a few times a year.

7. Setting the feed adjuster # for maximum burn: With the unit burning in "AUTO", turn to "Stove Mode" and put the fan on "H". Set the Temperature Dial to #7. Allow the unit to burn for about 30 minutes and check ash on front of burn pot. Fig. 28. If the ash line is larger than 1", turn the feed adjuster from #3 to #4. Allow another 30 minutes of burn time and check again. If, at #6 setting, a 1" or less ash bed is not obtainable, it is not a problem. The 1" ash bed is only a maximum burn rate and at most normal settings the ash bed will be larger.

Starting Fire

Igniter Switch to "MANUAL" (up position)

Make sure the unit is plugged into a 120 VAC, 60 HZ electrical source. The power light should be the only light lit.

To avoid unwanted smoke, be sure there is no fuel in the ash pan prior to lighting.

1. Turn FEED ADJUSTER to desired feed rate. No. 4 is good for most pellets.⁴
2. Turn the MODE SELECTOR to "OFF" and then to the desired mode. This will reset control and start the combustion motor.
3. Turn the TEMPERATURE DIAL to the desired setting.
4. Clean burn pot with scraper if necessary.⁵
5. Fill burn pot with pellets, only level with front edge. (Do Not Over Fill).
6. Add starting gel on top of the pellets. Stir gel into pellets for fast lighting.
7. Light starting gel with a match, and close the door. Operation will begin when the fire reaches the proper temperature.³
8. Fill hopper with pellets and remove ashes as required.^{1, 6}

WARNING

KEEP ALL DOORS AND HOPPER LID CLOSED DURING OPERATION.

WARNING

"NEVER USE GASOLINE, GASOLINE-TYPE LANTERN FUEL, KEROSENE, CHARCOAL LIGHTER FLUID, OR SIMILAR LIQUIDS TO START OR "FRESHEN UP " A FIRE IN THIS HEATER. KEEP ALL SUCH LIQUIDS WELL AWAY FROM THE HEATER WHILE IN USE".

WARNING

ONLY USE THE SPECIFIED FUELS. DO NOT BURN GARBAGE IN STOVE.

Room Sensor Installation

Room Sensor Installation



Fig. 31

The room sensor is a small temperature sensor on the end of a 60" wire. This sensor is installed much like a standard wall thermostat. Because it is so small, it can be hidden along the trim of a doorway or even up the leg of a coffee table. There is a remote room sensor port on the rear of the unit for easy external connection. Use standard 18-2 thermostat wire to extend the distance to the desired location (50' maximum). The room sensor should be installed in the location where you want to control the temperature.

In most installations locating the room sensor behind the stove near the distribution fan works well because the sensor monitors the room air being drawn into the distribution fan.

NOTE: Distances of more than 25 feet from the unit or in another room are not recommended. The room sensor is essential for the XXV's excellent efficiency.

NOTE: **It is recommended that the room sensor be installed,** even if only installed on the rear of the unit as a return air sensor.

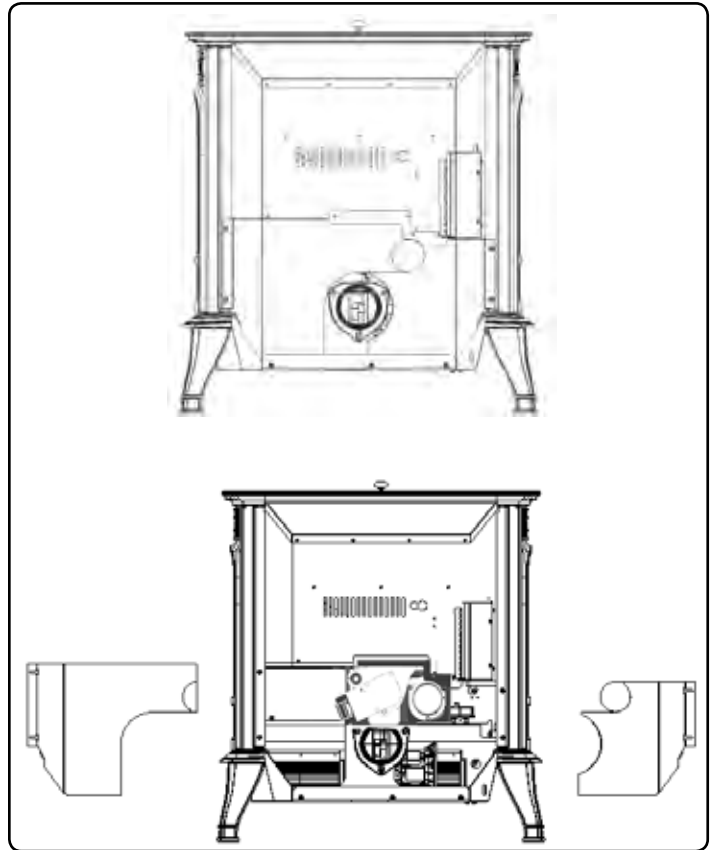


Fig. 32

Maintenance



Fig. 33



Fig. 34



Fig. 35

Removing Ashes:

Fuel quality and moisture content will dictate how often it will be necessary to empty the ash pan.

Disposal of Ashes

Ashes should be placed in a metal container with a tight fitting lid. The closed container of ashes should be placed on a noncombustible floor or on the ground, well away from all combustible materials, pending final disposal. If ashes are disposed of by burial in soil or otherwise locally dispersed, they should be retained in the closed container until all cinders have thoroughly cooled.

It is recommended that the stove is cold and shut down for removing the ash pan.

1. Open the front door of the stove and then open the ash door by pulling downward on the ash lip. Remove the ash pan (be sure to wear protective gloves if the stove is not cooled down). See Fig. 33.
2. Slide the ash pan back into the stove, seating it against the rear of the firebox. Lift the ash lip to close the ash door and then close the front door of the stove.

Cleaning:

The stove should be cleaned after burning approximately 1 ton of pellets (50 bags). The cleaner the stove, the more efficient it will be. You will burn less pellets and heat output will be greater.

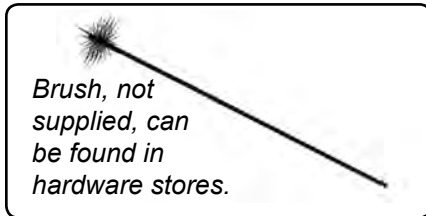
Note: Higher ash content pellets will require more frequent cleaning.

1. Shut down the stove and **disconnect power cord** to insure that all motors are stopped.
2. Clean the heat exchanger with scraper as shown in fig 34.
3. Brush or scrape the inside of the stove to remove fly ash.
4. Scrape the burn pot with the flat end of the scraper provided with the stove. Inspect the holes on the burn pot surface. See Fig. 35.
5. Open the burn pot clean-out. Clean fly ash from the burn pot and replace the cover. See Figures 39 and 40 on page 26.

Maintenance

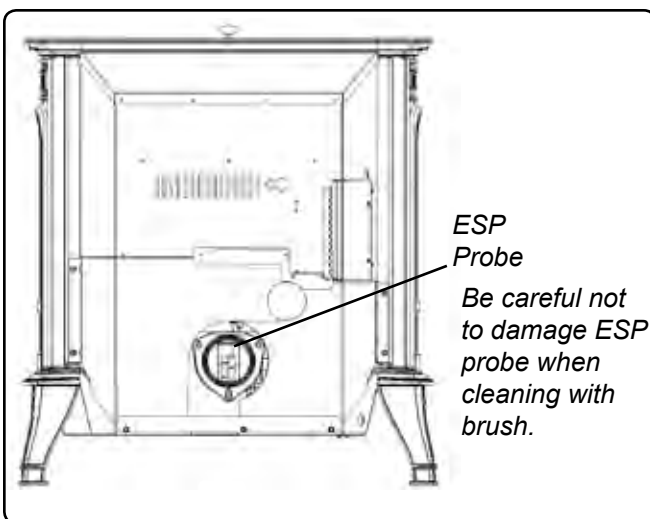


Fig. 36



Brush, not supplied, can be found in hardware stores.

Fig. 37



ESP Probe

Be careful not to damage ESP probe when cleaning with brush.

Fig. 38

6. Remove the ash pan and dispose of ashes in an approved manner, according to local codes.
7. Remove the combustion blower by loosening the 3 wing nuts, twisting the combustion blower mount plate counterclockwise to unlock, and pulling the blower out.
8. Clean the combustion blower wheel with a brush and a vacuum cleaner. Note: Do not use a household vacuum to clean the stove. We recommend that you use a shop vacuum that is equipped with a fine dust filter called a HEPA filter or a vacuum specially made for fly ash and soot. **USING A VACUUM WHICH IS NOT EQUIPPED WITH A FINE DUST FILTER WILL BLOW FLY ASH AND SOOT OUT INTO THE ROOM.**

NOTE: THE STOVE MUST BE COMPLETELY OUT BEFORE YOU VACUUM THE STOVE. LIVE PELLET EMBERS, IF SUCKED INTO THE VACUUM, WILL LIGHT THE VACUUM ON FIRE AND MAY ULTIMATELY CAUSE A HOUSE FIRE.

9. Use a brush to clean the flue, being careful not to damage the ESP probe.
10. Reinstall the combustion blower by turning plate clockwise to lock into place and tightening the 3 wing nuts. Be sure the fan plate is flush with the exhaust housing on the stove body and the motor armature points up toward the hopper.
11. Slide ash pan into the stove and latch the door.

Soot and Fly Ash

Formation and Need for Removal - The products of combustion will contain small particles of flyash. The flyash will collect in the exhaust venting system and restrict the flow of exhaust gases. Incomplete combustion, such as occurs during startup, shutdown, or incorrect operation of the room heater will lead to some soot formation which will collect in the exhaust venting system. **The entire exhaust venting system should be professionally cleaned at least once every year.**

Removing fly ash and soot improves efficiency and insures that the flue venting passageway is clear and unobstructed. The stove should be cleaned after each ton of pellets (50 bags) and the venting system inspected and cleaned after each heating season.

Maintenance - Burn Pot



Fig. 39



Fig. 40

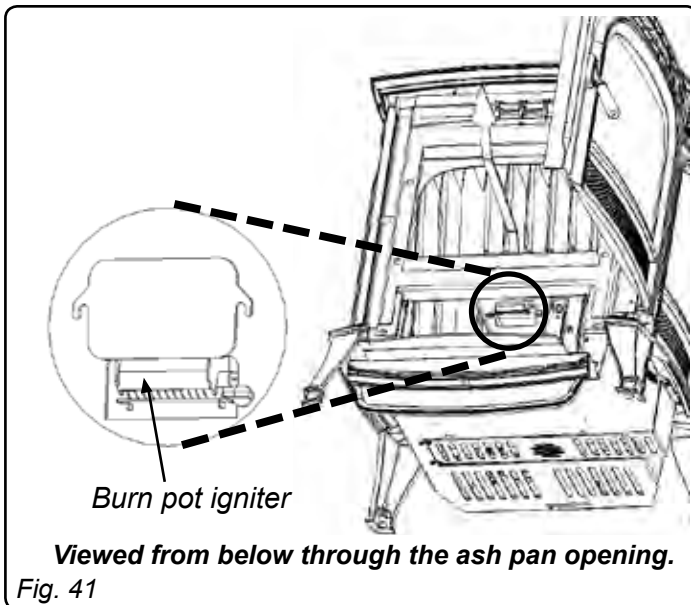


Fig. 41

Burn Pot Cleaning and Maintenance

1. Scrape the top holed surface and sides of the burn pot. (Fig 39) It is not necessary to completely remove all loose material from the burn pot. The excess will be pushed out during the next use.

DANGER

Disconnect the power to the unit before removing cover.

2. Loosen the (2) wing thumb screws on the lower front angle of the burn pot. (Fig. 39)

3. Lift off the clean-out cover (Fig.40) to open the bottom clean-out chamber. (Fig.41)

4. Clean ash buildup from inside the chamber while cover is off. Use the scraper to tap on the top front edge of the burn pot. This will help knock pieces of ash, loosened by the scraping process, down through the holes. It also helps knock scale off of the igniter element.

Figure 41

The igniter is made to be removable for service by insulated male/female wire connectors. These connections between the hot leads (the wires inside the burn pot) and the cold leads (the wires from the control board) are always pulled to the rear of the feeder body. **(Not coiled inside the burn pot.)**

It is very important that these connections are to the inside rear of the feeder body. Also, the extra wire of the igniter wire service loop must be pulled out through the rear of the feeder and tied up so that it will not be damaged by any moving parts.

Note: The hot lead/cold lead connection must always be pulled to the rear of the feeder body before operation.

WARNING

Use caution when cleaning burn pot clean-out chamber. Do not damage the high temperature igniter wires.

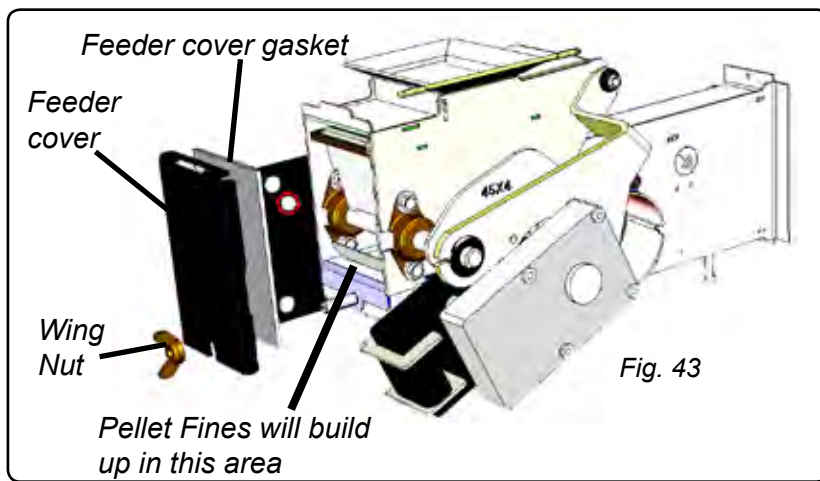
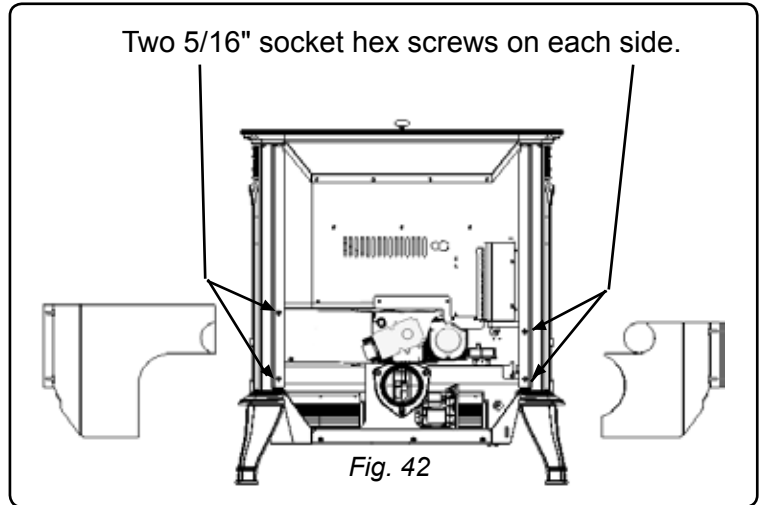
Whenever wood is burned, there is a potential for creosote formation. The venting system should be inspected periodically during the heating season to determine if a creosote buildup has occurred. If a significant layer of creosote has accumulated (3 mm or more), it should be removed to reduce the risk of a chimney or venting system fire.

Maintenance

Pellet fines will accumulate in the feeder body over a period of time; therefore, a yearly inspection and cleaning of this must be performed.

To clean out fines:

1. Remove right rear cover panel.
2. Remove wing nut and feeder cover on the right side of the feeder. See Fig. 43.
3. Use a vacuum cleaner to remove all fines.
4. Reinstall feed cover, wing nut, and right rear cover panel.



Viewing Glass

The glass in your Harman stove is a special ceramic glass.

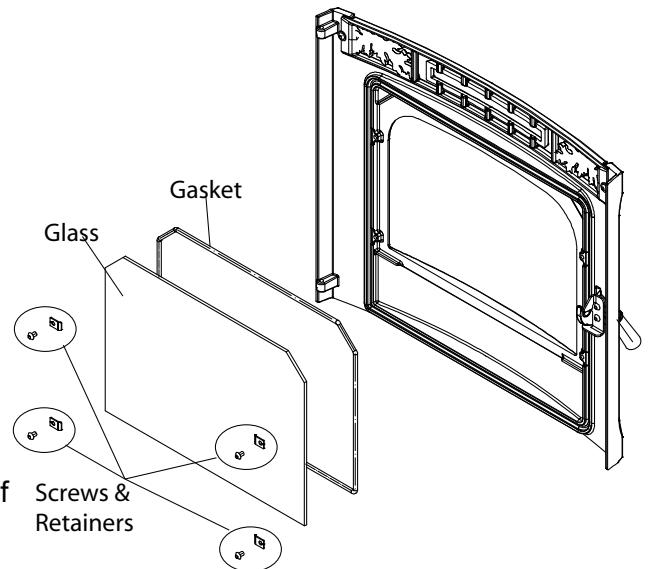
- Do not abuse the glass by striking or slamming the door.
- Never burn the appliance if the door glass is cracked or broken.
- Replace only with Harman supplied glass.

Soot and/or fly-ash may accumulate on the viewing glass, and will occasionally need to be cleaned. Clean the glass with a soft cloth and mild glass cleaner. Do not clean the glass when hot, and avoid the use of abrasive cleaners.

Glass replacement

Carefully remove all remaining glass and gasket materials prior to replacing the glass.

Lay the door face down on a flat surface. Remove the glass retainers and screws. Apply the gasket material to the face of the new glass. Lay the glass into the door, making sure that the glass is contained within the channels and raised areas of the door itself. Lay the glass retainers into position and install the screws. Tighten each screw evenly to avoid making any stress points.



Options

XXV Top Flue Option

The Top Flue option attaches to the exhaust on the rear of the stove, and extends it to the top with a six inch stub.

This gives the appearance of a wood stove and also allows venting with existing single wall, connector. A 12 inch piece of 4" pellet vent is included to act as an insulator only. Note: The top flue adaptor is not approved for use with pellet vent pipe. It is only tested for use with chimney connector (6- inch pipe) into an existing "class A" chimney.

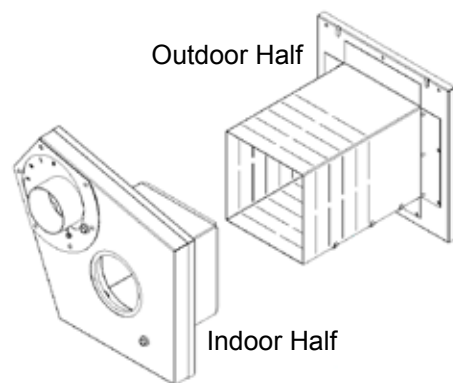
Harman Part #1-00-677120



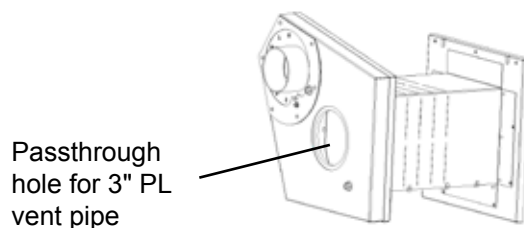
Direct Vent Wall Passthrough

The Harman Direct Vent Wall Passthrough makes installing your Harman Pellet Stove with outside air a lot easier. It is made to fit walls from 4 1/2" up to 10 1/8" thick with a square opening of 6" to 6 1/2".

Harman Part #1-00-677077



Adjustable from 4 1/2" to 10 5/8" wall thickness



Trouble-Shooting

STOVE DOES NOT FEED

1. No fuel in hopper.
2. Firebox draft may be too low for sensing switch in feeder circuit to operate. **Check for closed doors**, loose or missing gasket on doors or hopper lid.
3. Hopper lid must contact the lid position switch.
4. Feed motor will not run until the ESP control senses a certain temperature. Maybe you did not put enough fuel or starting gel in the burn pot before manually lighting the fire.
5. Restriction in the hopper or feeder. Remove all fuel and examine. Clear the obstruction.
6. Feed motor has failed.

PARTIALLY BURNED PELLETS

1. Feed rate too high.
2. Poor air to fuel mixture. (Check burn pot clean-out cover and air intake).
3. Burn pot or heat exchanger tubes may need to be cleaned.
4. Combination of all the above.
5. **#6 status blink:** A 6 blink control board status indication is caused by poor or incomplete combustion. The circuit board has the ability to track the combustion through feed settings and ESP temperatures. When the control board has calculated poor or incomplete combustion, it will shut down the unit as a safety feature. (Poor or incomplete combustion is a contributor of creosote which may cause a chimney fire)

A 6 blink status may be caused by several things:

1. Blocked or partially blocked flue.
2. Blocked or partially blocked inlet air.
 - a. Backdraft damper on the inlet pipe may be stuck closed.
 - b. If outside air is installed, the inlet cover may be blocked.
3. The air chamber under the burnpot may be filled with fines and small bits of ash.
4. The holes in the burnpot may be getting filled with ash or carbon buildup.
5. Combustion blower fan blades may need cleaned.
6. Fuel restrictions as noted above.

SMOKE SMELL

Seal the vent pipe joints and connection to stove with silicone. The exhaust vent is the only part of the system that is under positive pressure.

FIRE HAS GONE OUT- Check for status light.

1. No fuel in hopper.
2. Draft is too low, blocked flue.
3. Something is restricting fuel flow.
4. Hopper lid not closed properly.
5. Feed motor or combustion blower has failed.

SMOKE IS VISIBLE COMING OUT OF VENT

1. Air-fuel ratio is too rich.
 - A. Feed rate too high.
 - B. Draft too low caused by a gasket leak.

LOW HEAT OUTPUT

1. Feed rate too low
2. Draft too low because of gasket leak.
3. Poor quality or damp pellets
4. Combination of 1 and 2.

Helpful Hints

Cleaning Burn Pot

Whenever your stove is not burning, take the opportunity to scrape the burn pot to remove carbon buildup. A vacuum cleaner is handy to remove the residue. **Be sure the stove is cold if you use a vacuum.**

Carbon buildup can be scraped loose with the fire burning using the special tool provided with your stove. Scrape the floor and sides of the burn pot. The carbon will be pushed out by the incoming fuel. Always wear gloves to do this.

Removing Ashes

Turn the Temp Dial to number 1 approximately 30 minutes before removing ashes. This will result in a cooler stove and ash pan.

Maximum Feed Adjuster settings are not needed in most cases. Operating in the normal range (#4) is recommended when maximum heat output is not required. The ESP probe prevents the stove from being over-fired.

Keep the stove free of dust and dirt.

Fuel

See page 3 for detailed fuel information.

Wood Pellet size is regulated at .23" to .35" in diameter with a maximum length of 1.5" long.

Pellet fuels are put into 3 categories in terms of ash content. Premium at 1% or less, Standard at 3% or less and all others at 3% or more.

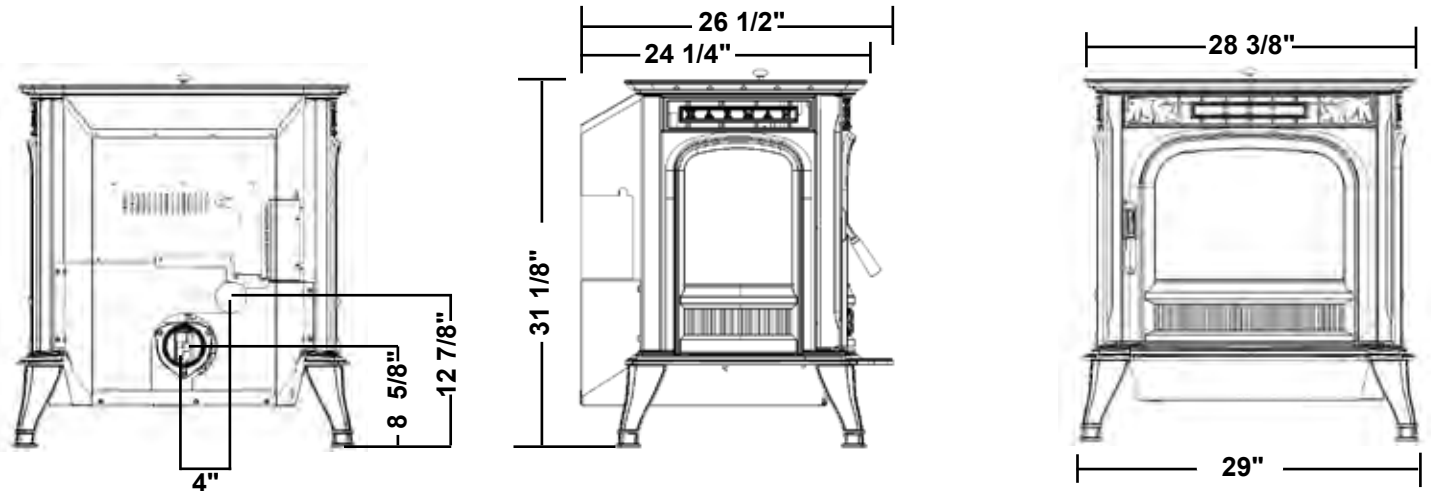
The XXV is capable of burning all 3 categories of pellets or a mixture of up to 50% shelled corn and pellets.

It should be noted, fuels with higher ash content will require more frequent; ash removal, scraping of the burn pot, increased cleaning frequency and may provide less BTU's per pound.

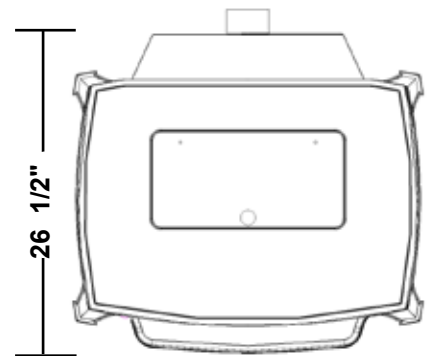
The moisture content of pellets must not exceed 8%, and Corn 15%. Higher moisture will rob BTU's and may not burn properly.

Fuel should **not** be stored within the stove installation clearances or within the space required for charging and ash removal. See Page 7.

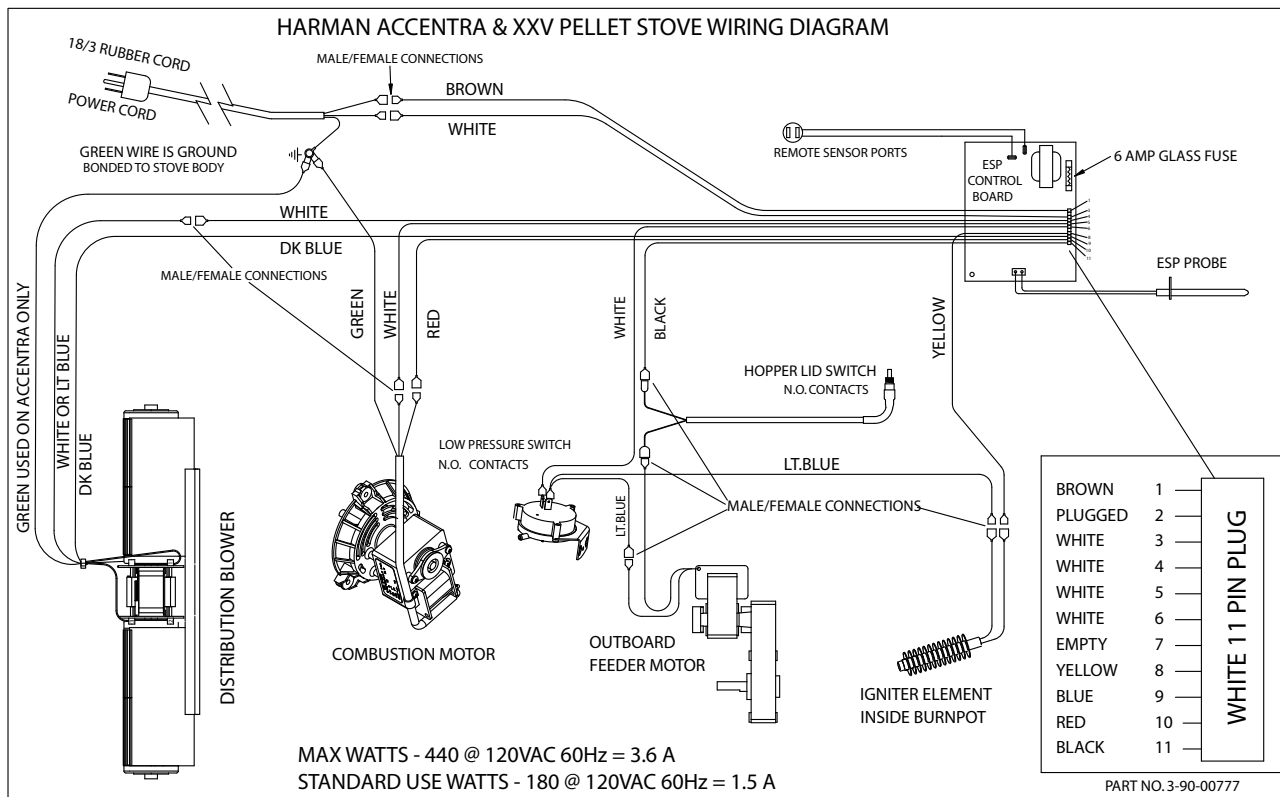
Specifications



Weight	375 lbs.
Blower	150 cfm
Feed Rate	approx. 1lb. to 5.75 lbs/hr.
Hopper Capacity	65 lbs
Fuel	Wood Pellets or Corn/Pellet mixture
Flue Size	3 inch or optional 6" top exit
Outside Air Size	2 3/8" I.D. inch
Fuse Rating	6 amp



Wiring Diagram



Addendum

Minimizing Smoke During Loss of Power Using Battery Back-up

Harman™ strongly recommends installing battery back-up to minimize entry of smoke into the room in the event of power loss.

Your pellet/biomass burning appliance relies on a combustion blower to remove exhaust. A power failure will cause the combustion blower to stop. This may lead to exhaust seeping into the room. Vertical rise in the venting may provide natural draft. It is, however, no guarantee against leakage.

There are two Harman™ approved battery back-up options for your appliance:

Uninterruptible Power Supply (UPS) UPS battery back-ups are available online or at computer and office equipment stores. Your Harman™ appliance with Rev E or later software available beginning in November 2010 may be plugged directly into a Harman™ approved UPS:

- The APC (American Power Conversion) model #BE750G and the TrippLite model INTERNET750U are tested and approved. Other brands or models may not be compatible.

When power is lost, a fully charged UPS will power a safe, combustion blower only shut-down. Your appliance will pulse the blower every few seconds to clear exhaust until the fire is out. **NOTE: The UPS provides safe shut-down only. It is not intended for continued operation.**

Your appliance will recognize when power is restored. What happens depends on ESP temperature and whether it is equipped with automatic ignition:

- In **“Automatic” setting**, units equipped with automatic ignition will respond to the set point and ESP temperature and resume normal operation.
- In **“Manual” setting** or for units without automatic ignition:
 - If the ESP is cool, the appliance will remain shut down.
 - If the fire is out and the ESP is still warm, the feeder may restart. Since the fire is out, the ESP temperature will not rise. The unit will then shut-down, and may flash a six-blink status error. (See *ESP error codes*)
 - If the fire is still burning, it will resume normal operation.

Contact your dealer if you have questions about UPS compatibility with your appliance.

Harman Surefire 512H Battery Back-up The 512H connects to a 12 volt deep cycle battery that will run your appliance for up to eight (8) hours. It includes a trickle charge feature that keeps your battery charged when power is available. **NOTE: If the power is out for longer than battery life, smoke leakage may still occur unless your stove has been safely shut down.**

CAUTION! Always keep appliance doors and hopper lid closed and latched during operation and during power failures to minimize risk of smoke or burn-back.

CAUTION! Use only Harman™ approved battery back-up devices. Other products may not operate properly, can create unsafe conditions or damage your appliance.

**Hearth & Home Technologies Inc.
LIMITED LIFETIME WARRANTY**

Hearth & Home Technologies Inc., on behalf of its hearth brands ("HHT"), extends the following warranty for HHT gas, wood, pellet, coal and electric hearth appliances that are purchased from an HHT authorized dealer.

WARRANTY COVERAGE:

HHT warrants to the original owner of the HHT appliance at the site of installation, and to any transferee taking ownership of the appliance at the site of installation within two years following the date of original purchase, that the HHT appliance will be free from defects in materials and workmanship at the time of manufacture. After installation, if covered components manufactured by HHT are found to be defective in materials or workmanship during the applicable warranty period, HHT will, at its option, repair or replace the covered components. HHT, at its own discretion, may fully discharge all of its obligations under such warranties by replacing the product itself or refunding the verified purchase price of the product itself. The maximum amount recoverable under this warranty is limited to the purchase price of the product. This warranty is subject to conditions, exclusions and limitations as described below.

WARRANTY PERIOD:

Warranty coverage begins on the date of original purchase. In the case of new home construction, warranty coverage begins on the date of first occupancy of the dwelling or six months after the sale of the product by an independent, authorized HHT dealer/ distributor, whichever occurs earlier. The warranty shall commence no later than 24 months following the date of product shipment from HHT, regardless of the installation or occupancy date. The warranty period for parts and labor for covered components is produced in the following table.

The term "Limited Lifetime" in the table below is defined as: 20 years from the beginning date of warranty coverage for gas appliances, and 10 years from the beginning date of warranty coverage for wood, pellet, and coal appliances. These time periods reflect the minimum expected useful lives of the designated components under normal operating conditions.

Warranty Period		HHT Manufactured Appliances and Venting							Components Covered
Parts	Labor	Gas	Wood	Pellet	EPA Wood	Coal	Electric	Venting	
1 Year		X	X	X	X	X	X	X	All parts and material except as covered by Conditions, Exclusions, and Limitations listed
2 years				X	X	X			Igniters, electronic components, and glass
		X	X	X	X	X			Factory-installed blowers
				X					Molded refractory panels
3 years				X					Firepots and burnpots
5 years	1 year			X	X				Castings and baffles
7 years	3 years		X	X	X				Manifold tubes, HHT chimney and termination
10 years	1 year	X							Burners, logs and refractory
Limited Lifetime	3 years	X	X	X	X	X			Firebox and heat exchanger
90 Days		X	X	X	X	X	X	X	All replacement parts beyond warranty period

See conditions, exclusions, and limitations on next page.

WARRANTY CONDITIONS:

- This warranty only covers HHT appliances that are purchased through an HHT authorized dealer or distributor. A list of HHT authorized dealers is available on the HHT branded websites.
- This warranty is only valid while the HHT appliance remains at the site of original installation.
- Contact your installing dealer for warranty service. If the installing dealer is unable to provide necessary parts, contact the nearest HHT authorized dealer or supplier. Additional service fees may apply if you are seeking warranty service from a dealer other than the dealer from whom you originally purchased the product.
- Check with your dealer in advance for any costs to you when arranging a warranty call. Travel and shipping charges for parts are not covered by this warranty.

WARRANTY EXCLUSIONS:

This warranty does not cover the following:

- Changes in surface finishes as a result of normal use. As a heating appliance, some changes in color of interior and exterior surface finishes may occur. This is not a flaw and is not covered under warranty.
- Damage to printed, plated, or enameled surfaces caused by fingerprints, accidents, misuse, scratches, melted items, or other external sources and residues left on the plated surfaces from the use of abrasive cleaners or polishes.
- Repair or replacement of parts that are subject to normal wear and tear during the warranty period. These parts include: paint, wood, pellet and coal gaskets, firebricks, grates, flame guides, light bulbs, batteries and the discoloration of glass.
- Minor expansion, contraction, or movement of certain parts causing noise. These conditions are normal and complaints related to this noise are not covered by this warranty.
- Damages resulting from: (1) failure to install, operate, or maintain the appliance in accordance with the installation instructions, operating instructions, and listing agent identification label furnished with the appliance; (2) failure to install the appliance in accordance with local building codes; (3) shipping or improper handling; (4) improper operation, abuse, misuse, continued operation with damaged, corroded or failed components, accident, or improperly/incorrectly performed repairs; (5) environmental conditions, inadequate ventilation, negative pressure, or drafting caused by tightly sealed constructions, insufficient make-up air supply, or handling devices such as exhaust fans or forced air furnaces or other such causes; (6) use of fuels other than those specified in the operating instructions; (7) installation or use of components not supplied with the appliance or any other components not expressly authorized and approved by HHT; (8) modification of the appliance not expressly authorized and approved by HHT in writing; and/or (9) interruptions or fluctuations of electrical power supply to the appliance.
- Non-HHT venting components, hearth components or other accessories used in conjunction with the appliance.
- Any part of a pre-existing fireplace system in which an insert or a decorative gas appliance is installed.
- HHT's obligation under this warranty does not extend to the appliance's capability to heat the desired space. Information is provided to assist the consumer and the dealer in selecting the proper appliance for the application. Consideration must be given to appliance location and configuration, environmental conditions, insulation and air tightness of the structure.

This warranty is void if:

- The appliance has been over-fired or operated in atmospheres contaminated by chlorine, fluorine, or other damaging chemicals. Over-firing can be identified by, but not limited to, warped plates or tubes, rust colored cast iron, bubbling, cracking and discoloration of steel or enamel finishes.
- The appliance is subjected to prolonged periods of dampness or condensation.
- There is any damage to the appliance or other components due to water or weather damage which is the result of, but not limited to, improper chimney or venting installation.

LIMITATIONS OF LIABILITY:

- The owner's exclusive remedy and HHT's sole obligation under this warranty, under any other warranty, express or implied, or in contract, tort or otherwise, shall be limited to replacement, repair, or refund, as specified above. In no event will HHT be liable for any incidental or consequential damages caused by defects in the appliance. Some states do not allow exclusions or limitation of incidental or consequential damages, so these limitations may not apply to you. This warranty gives you specific rights; you may also have other rights, which vary from state to state. EXCEPT TO THE EXTENT PROVIDED BY LAW, HHT MAKES NO EXPRESS WARRANTIES OTHER THAN THE WARRANTY SPECIFIED HEREIN. THE DURATION OF ANY IMPLIED WARRANTY IS LIMITED TO DURATION OF THE EXPRESSED WARRANTY SPECIFIED ABOVE.

Addendum for Burning Corn and Pellet Fuel Mixture

Harman pellet burning, free-standing stoves and inserts have been tested to ASTM E1509 for burning shelled corn in a mixture with wood pellets. The listing approves up to a 50% corn and 50% pellet mixture. Different mixtures of corn will have distinctively different burn characteristics depending upon moisture content and variety. The operator should closely monitor the stove's operation when burning a new corn/pellet mixture or a different variety of corn, and make any necessary adjustments to feed rate. Since corn is typically higher in ash and moisture content, cleaning and ash removal will be needed more frequently.

Operation in Stove Temp mode

Set feed adjuster to # 3. Set temperature knob to #3, Turn mode selector knob onto "Stove Temp" mode. After the fire has lit, watch that the fuel does not feed too fast that it pushes the red glowing fuel bed off of the burn pot grate. If it does, lower the feed adjuster setting or use a lower percentage of corn in the mixture. After the stove has burned for 10 minutes and the entire fuel bed is burning, the feed adjuster and temperature knobs may be adjusted for higher heat output if desired. Maximum feed has been reached when the fire bed is about ½ to 1 inch from the end of the burn pot. Settings will vary with different types, moisture levels and mix ratios of corn. If you are having difficulty burning a 50% corn / 50% wood pellet mixture, try a lower percentage of corn.

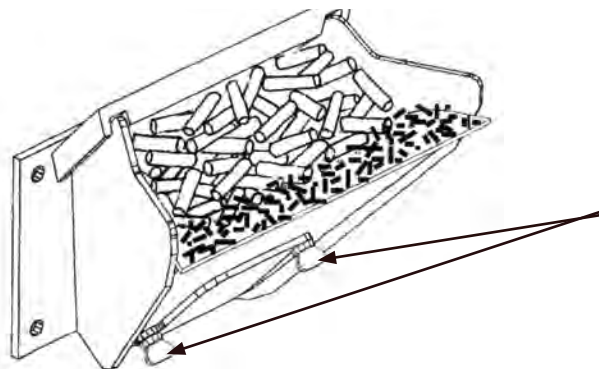
Operation in Room Temp mode

Set feed adjuster to # 2 or # 3. Set temperature knob to desired amount. Turn mode selector knob onto "Room Temp" mode. After the fire has lit, watch that the fuel does not feed too fast that it pushes the red glowing fuel bed off of the burn pot grate. After the stove has burned for 10 minutes and the entire fuel bed is burning, the feed adjuster may be set to a higher output level if desired. Maximum feed has been reached when the fire bed is about ½ to 1 inch from the end of the burn pot. It is recommended that after burning at the desired settings, turn the stove off and allow it to cool, then turn it back on in "Room Temp" mode and watch the stove restart and verify correct operation. Settings will vary with different types, moisture levels and mix ratios of corn. If you are having difficulty burning a 50% corn 50% wood pellet mixture, try a lower percentage of corn.

Changes to Maintenance Schedule

Wood pellets average around 6% moisture content or less. Corn will be 14 or 15% moisture. With more moisture in the fuel, more maintenance will be incurred. Burn pot scraping may need to be done once per day. The ash pan will fill more quickly and may need emptied weekly. Most importantly, remove the burn pot cleanout cover weekly to clean the air passage and the igniter element. Excessive buildup on the igniter may lead to shortened igniter life.

Venting Consideration: Check with your venting manufacturer regarding possible exclusions when a mixture of corn and pellets is burned.



Loosen these two wing screws for access to clean the air passage and igniter.

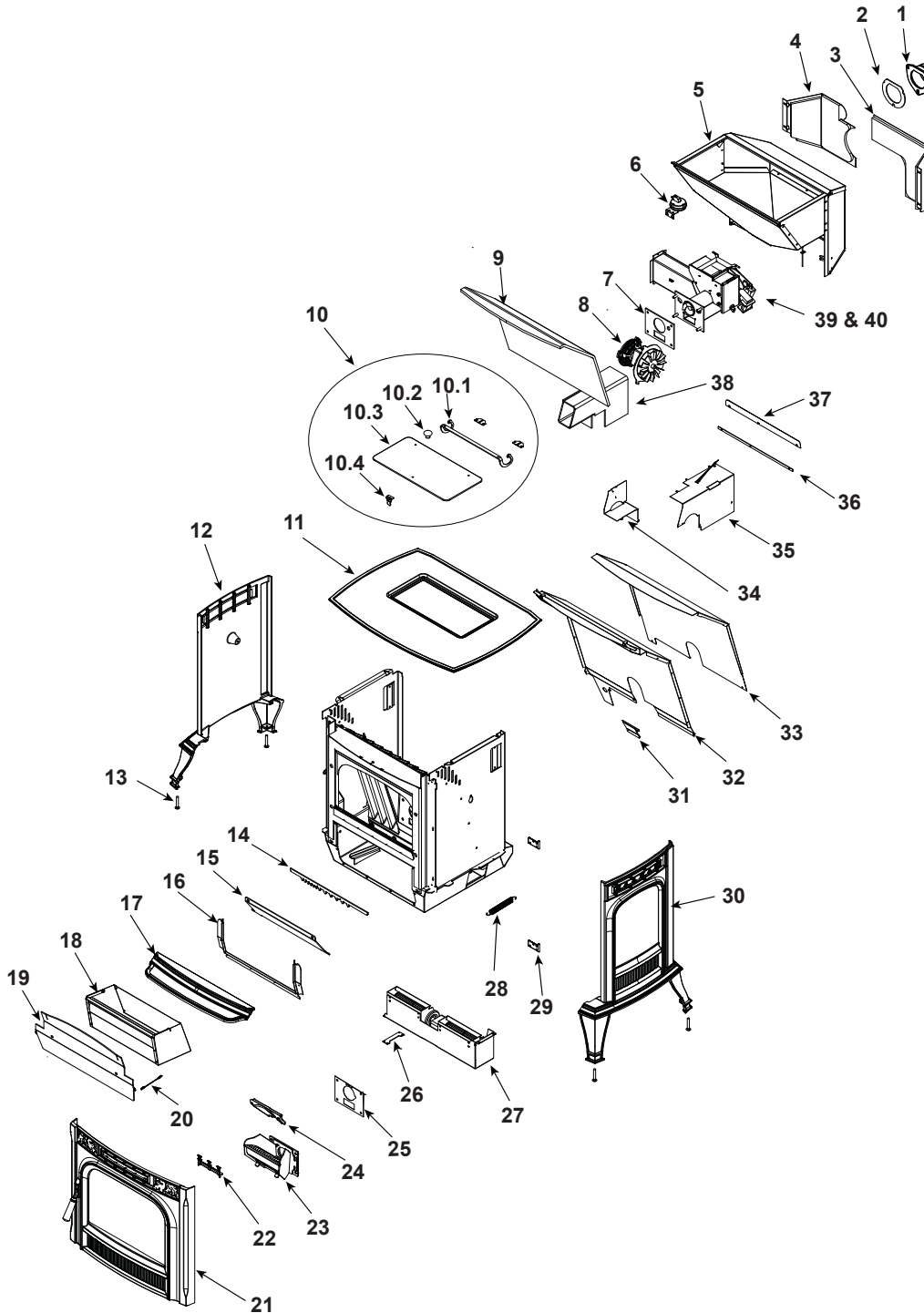
Pellet Stove

Beginning Manufacturing Date: N/A
Ending Manufacturing Date: Active

1-90-00677-1 (Black),
1-90-00677-2 (Charcoal),
1-90-00677-3 (Goldenfire),

1-90-00677-4 (Metallic Blue),
1-90-00677-5 (Honey Glo),
1-90-00677-10 (Mojave Red),

1-90-00677-12 (Forest Green),
1-90-00677-14 (Majolica Brown),
1-90-00677-19 (Bronze)
1-90-00025-2 (25th Anniversary Edition)



Part number list on following page.

IMPORTANT: THIS IS DATED INFORMATION. When requesting service or replacement parts for your appliance please provide model number and serial number. All parts listed in this manual may be ordered from an authorized dealer.



**Stocked
at Depot**

ITEM	DESCRIPTION	COMMENTS	PART NUMBER		
1	Pellet Tailpipe Cast		3-00-247237	Y	
2	Gasket, Pellet Tail pipe	Pkg of 5	1-00-07381	Y	
3	Right Feeder Shield		1-10-677085A	Y	
4	Left Feeder Shield		1-10-677084A	Y	
5	Hopper Assembly	Pre 12826	1-10-677800A	Y	
		Post 12826	1-10-677190A	Y	
	Gasket, Hopper Top		1-00-375501	Y	
	Hopper Switch		3-20-232108	Y	
6	Differential Switch		3-20-6866	Y	
7	Gasket, Burn Pot\Tailpipe	Pkg of 5	1-00-07381	Y	
8	Combustion Blower		3-21-08639	Y	
	Mounting Plate		1-10-677006		
9	Hopper Insulation		3-44-677037		
10	Hopper Lid		3-40-247100	Y	
10.1	Hinge		2-00-06694		
10.2	Hopper Knob	Gold	3-43-02000		
		Brushed Nickel	3-43-02000-8		
10.3	Hopper Plate	Qty. 2 Req.	2-00-06695L		
10.4	Hopper Lid Latch (Male and Female)	3 Sets	1-00-0669697	Y	
11	Top	Plain	4-00-677057		
		Bronze	1-10-667057-19		
		Brown			
		Pre 008206292	1-10-677057-14V		
		Post 008206292	1-10-677057-14		
12	Left Side	Plain	4-00-677055		
		Bronze	1-10-677055-19		
		Brown			
		Pre 008206292	1-10-677055-14V		
		Post 008206292	1-10-677055-14		
13	Leveler Feet	Pkg of 4	1-00-12302		
14	Airwash Reducer		1-00-677300		
15	Ash Door Stop		2-00-677096B		
16	Ash Door Gasket Retainer		2-00-677025B		
17	Ashlip	Plain	4-00-677058		
		Bronze	1-10-677058-19		
		Brown			
		Pre 008206292	1-10-677058-14V		
		Post 008206292	1-10-677058-14		

Additional service part numbers appear on following page.

IMPORTANT: THIS IS DATED INFORMATION. When requesting service or replacement parts for your appliance please provide model number and serial number. All parts listed in this manual may be ordered from an authorized dealer.

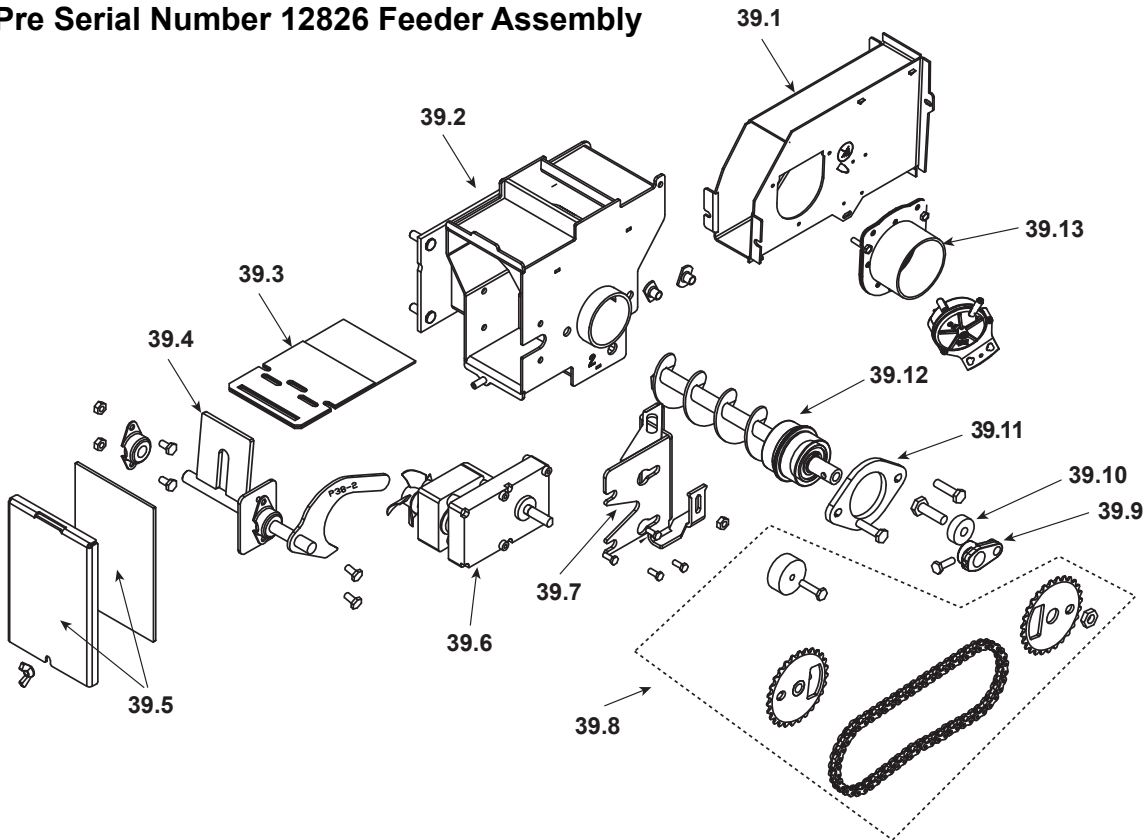


**Stocked
at Depot**

ITEM	DESCRIPTION	COMMENTS	PART NUMBER	
18	Ash Pan		1-10-677044	Y
19	Ash Door Weldment		1-10-677026A	
20	Cable Lanyard		3-31-677070	
21	Load Door Assembly	Plain	1-10-677099A	Y
		Bronze	1-10-677099A-19	Y
		Brown		
		Pre 008206292	1-10-677099-14V	Y
		Post 008206292	1-10-677099A-14	Y
	Door Only w/Rope	Plain	4-00-674053A	
		Brown		
		Pre 008206292	4-00-674053-14V	Y
		Post 008206292	4-00-674053-14S	Y
	Door Rope	30 Ft	1-00-00888	Y
	Handle Assembly	2 Sets	1-00-00247	Y
22	Letters		2-00-677022S	
23	Burn Pot		1-10-00675	Y
24	Flame Guide		3-00-03000	Y
25	Ceramic Insert Gasket		3-44-724114	Y
26	Distribution Blower Mount Plate		2-00-677006L	
27	Distribution Blower		3-21-29045	Y
28	Extension Spring		3-31-2181	
29	Hinge Plate	Qty. 2 req.	3-00-674047	
30	Right Side	Plain	4-00-677056	
		Brown		
		Pre 008206292	1-00-677056-14V	
		Post 008206292	1-10-677056-14	
		Bronze	1-10-677056-19	
31	Air Jacket Filler Plate		2-00-677039B	
32	Air Jacket		2-00-677035B	
33	Hopper Heat Shield		2-00-677038B	
34	Distribution Blower Heat Shield		2-00-677041B	
35	Combustion Box Heat Shield		2-00-677040B	
36	Rear Shield Spacer		2-00-677087L	
37	Rear Shield Retainer		2-00-677086L	
38	Combustion Assembly Insulation		3-44-677042	

Additional service part numbers appear on following page.

#39 Pre Serial Number 12826 Feeder Assembly



IMPORTANT: THIS IS DATED INFORMATION. When requesting service or replacement parts for your appliance please provide model number and serial number. All parts listed in this manual may be ordered from an authorized dealer.

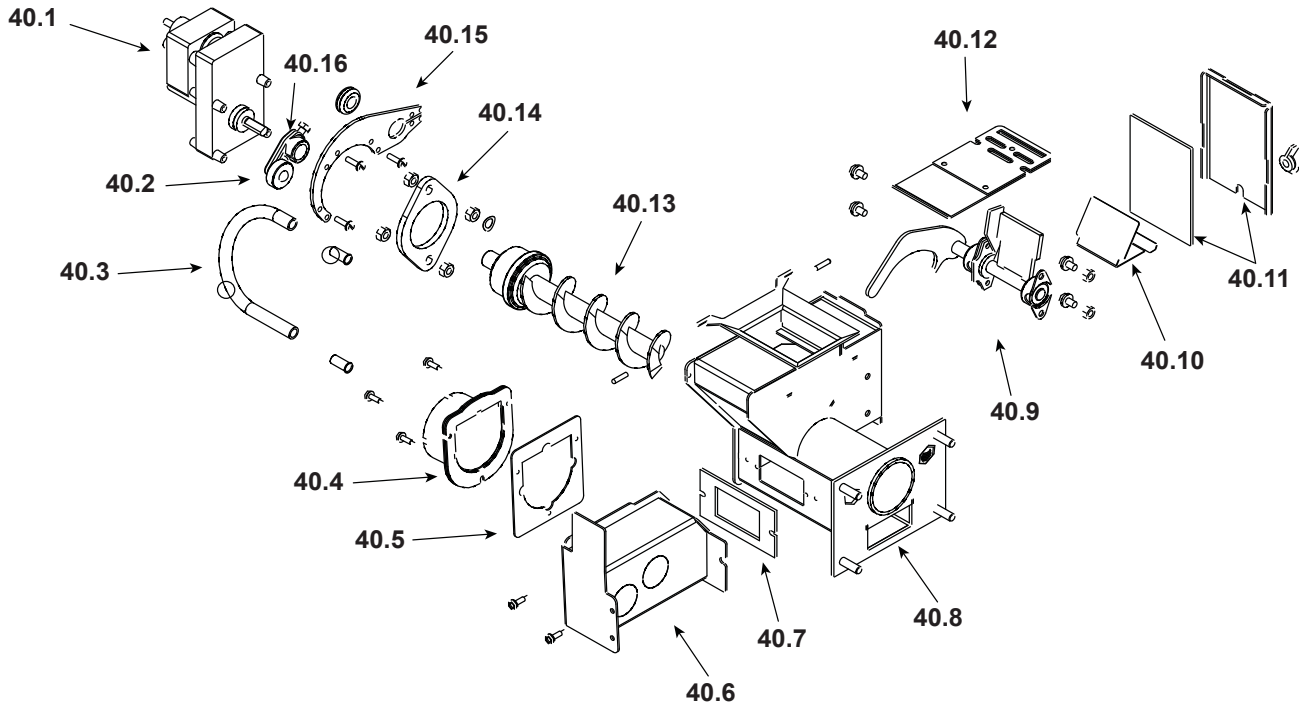


**Stocked
at Depot**

ITEM	Description	COMMENTS	PART NUMBER	
39	Feeder Assembly	Pre 12826	1-10-677153A	
39.1	Air Intake Weldment		1-10-677016W	
39.2	Feeder Weldment		1-10-677150	Y
39.3	Slide Plate Assembly		1-10-08037	Y
39.4	Pusher Arm Assembly		1-10-01530	Y
39.5	Feed Cover and Gasket	2 Sets	1-00-677152	Y
39.6	Gear Motor, 4 RPM		3-20-08752	Y
39.7	Bracket, Gear Motor		1-10-677005	Y
39.8	Sprocket Replacement Kit		1-00-06626	Y
39.9	Cast Cam Block		3-00-00153	Y
39.10	Cam Bearing		3-31-3014	Y
39.11	Bearing Flange w/Hardware		1-00-04035	Y
39.12	Auger Assembly		3-50-00465	Y
39.13	Air Intake Damper Assembly		1-10-06466W	
	Gasket, Feeder, Air Intake	Pkg of 6	3-44-72224-6	Y
	Feeder Replacement Kit		1-00-677150	Y

Additional service parts on following page.

#40 Post Serial Number 12826 Feeder Assembly



IMPORTANT: THIS IS DATED INFORMATION. When requesting service or replacement parts for your appliance please provide model number and serial number. All parts listed in this manual may be ordered from an authorized dealer.



Stocked at Depot

ITEM	Description	COMMENTS	PART NUMBER	
40	Feeder Assembly	Post 12826	1-10-677189A	
40.1	Pellet Feeder Gear Motor, 4 RPM		3-20-00677	Y
40.2	UL Feeder Cam Bearing		3-31-3014	Y
40.3	9MM Silicone Tube		1-00-511427	Y
40.4	Pellet Air Intake Assembly		1-10-06810A	
40.5	Gasket Feeder Air Intake	Pkg of 6	3-44-72224-6	Y
40.6	UL Feeder Air Intake		1-10-677183	
40.7	Gasket Ultra Air Intake	Pkg of 10	3-44-677160-10	Y
40.8	Ultra Feeder Weldment		1-10-724132	Y
40.9	UL Feeder Pusher Arm		1-10-677131W	Y
40.10	Fines Deflector	No longer available	2-00-677138-10	
40.11	Gasket, UL Feeder Cover		1-00-677122	Y
40.12	Slide Plate Assembly		1-10-677121A	Y
40.13	UL Feeder Auger Assembly		3-50-00565	Y
40.14	Bearing Flange w/Hardware		1-00-04035	Y
40.15	UL Feeder Gear Motor Bracket w/Grommet		1-00-247406	Y
40.16	UL Feeder Cam Block		3-00-677154	Y
	Gasket, Hopper Throat		3-44-677185	Y

Additional service parts on following page.

HARMAN™
HOME HEATING

Proudly Printed On 100% Recycled Paper

