

# Installation & Operating Manual

## The Harman PF 100 Pellet Pro Furnace

# HARMAN™

HOME HEATING

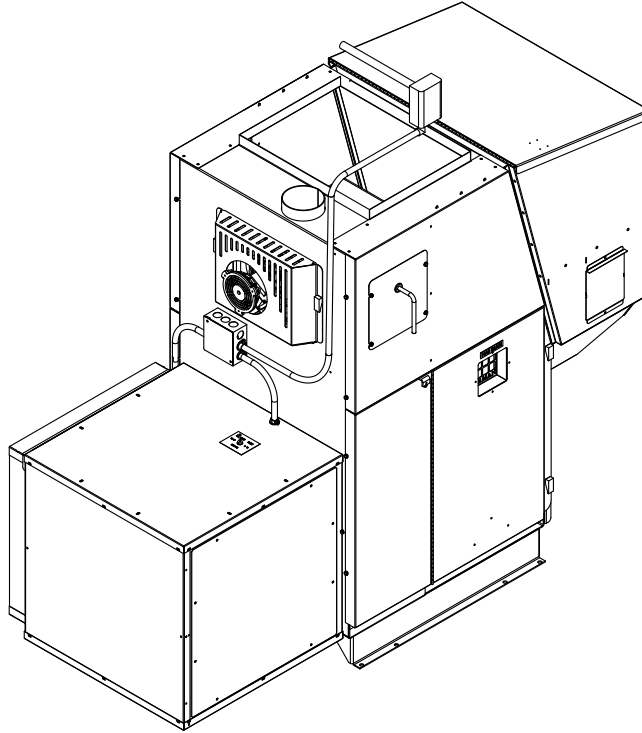

We suggest that our hearth products be installed and serviced by professionals who are certified in the U.S. by the National Fireplace Institute (NFI) as NFI Specialists.

*“Ce manuel est disponible en Français sur demande”*



## SAFETY NOTICE

**PLEASE READ THIS ENTIRE MANUAL BEFORE YOU INSTALL AND USE YOUR NEW FURNACE. FAILURE TO FOLLOW INSTRUCTIONS MAY RESULT IN PROPERTY DAMAGE, BODILY INJURY, OR EVEN DEATH.**

**FOR USE IN THE U.S. AND CANADA. SUITABLE FOR INSTALLATION IN MOBILE HOMES (SEE PG. 17).**

**IF THIS PELLET FURNACE IS NOT PROPERLY INSTALLED, A HOUSE FIRE MAY RESULT. FOR YOUR SAFETY, FOLLOW INSTALLATION DIRECTIONS.**

**CONTACT LOCAL BUILDING OR FIRE OFFICIALS ABOUT RESTRICTIONS AND INSTALLATION INSPECTION REQUIREMENTS IN YOUR AREA.**

**CONTACT YOUR LOCAL AUTHORITY (SUCH AS MUNICIPAL BUILDING DEPARTMENT, FIRE DEPARTMENT, FIRE PREVENTION BUREAU, ETC.) TO DETERMINE THE NEED FOR A PERMIT.**

**CETTE GUIDE D'UTILISATION EST DISPONIBLE EN FRANCAIS. CHEZ VOTRE CONCESSIONNAIRE DE HARMAN.**

**SAVE THESE INSTRUCTIONS.**

Item # 3-90-08101

# Parts Locator

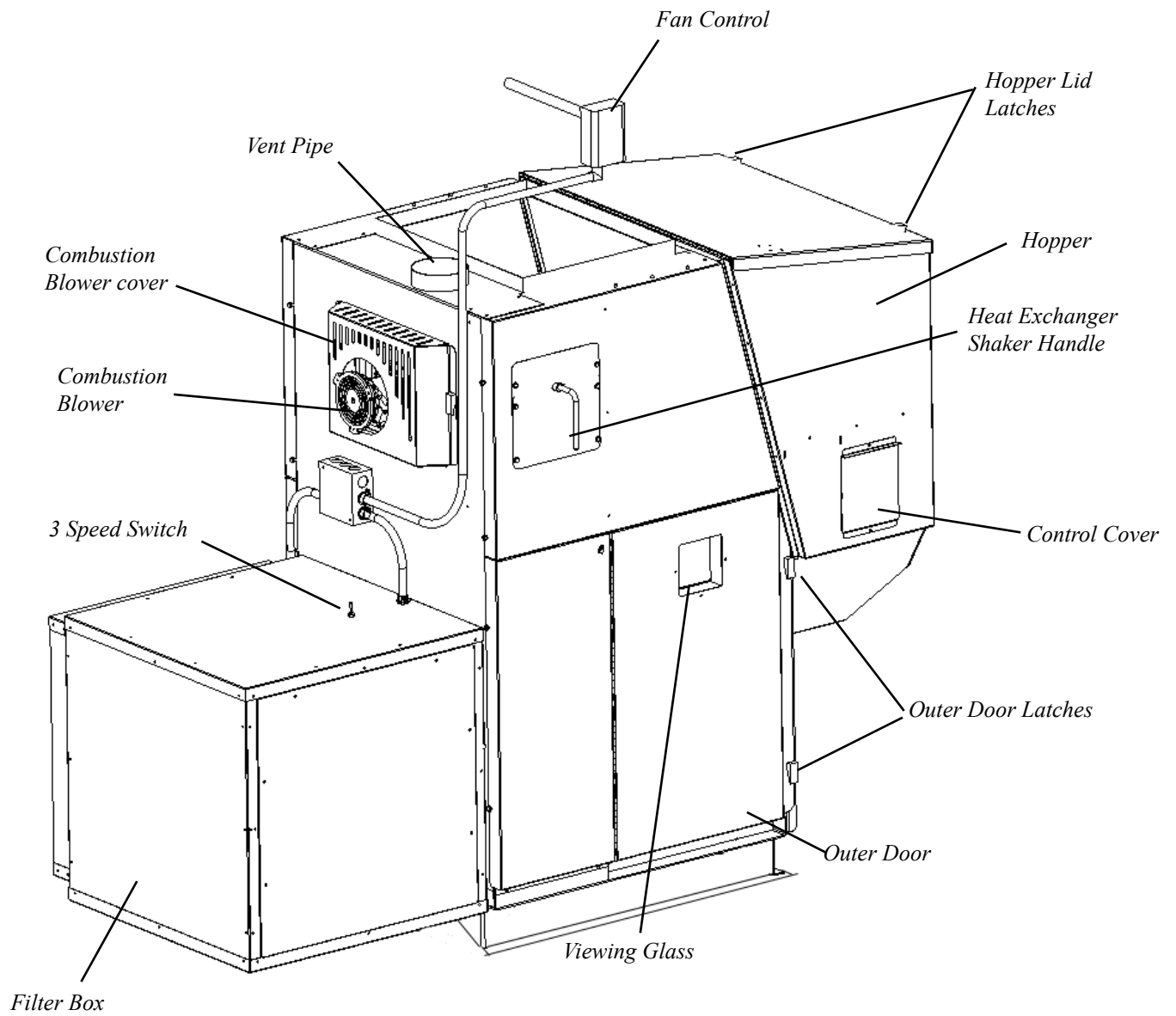

# Table of Contents

<b>Assembly</b>	<b>4</b>
<b>Venting</b>	<b>9</b>
<b>Installation</b>	<b>15</b>
<b>Mobile Home Requirements</b>	<b>17</b>
<b>Operation</b>	<b>21</b>
<b>Maintenance</b>	<b>29</b>
<b>Troubleshooting</b>	<b>34</b>
<b>Specifications</b>	<b>35</b>
<b>Wiring Diagram</b>	<b>36</b>
<b>Parts Information</b>	<b>37</b>
<b>Testing Label</b>	<b>43</b>
<b>Warranty</b>	<b>44</b>
<b>Fuel Specifications</b>	<b>46</b>
<b>Quick Reference Start-Up</b>	<b>Rear Cvr.</b>

Please read this entire manual before you install and use your new furnace. Failure to follow instructions may result in property damage, bodily injury, or even death.

## SAVE THESE INSTRUCTIONS

Hearth & Home Technologies, Inc.  
352 Mountain House Road  
Halifax, PA 17032

### Appliance Certification.

**Model:** Pellet Furnace - PF100

**Test Lab:** Omni-Test Laboratories, Inc.

**Report #:** 135-S-02-2

**Type:** Pellet Fueled Central/Supplementary For  
Residential Use

**Standard(s):** CAN/CSA B366.1-M91, UL 391,  
ASTM E1509-04 & ULC C1482- M1990

Note: This appliance is also approved for  
installation into a shop.

## Filter Box (Cold Air Return)

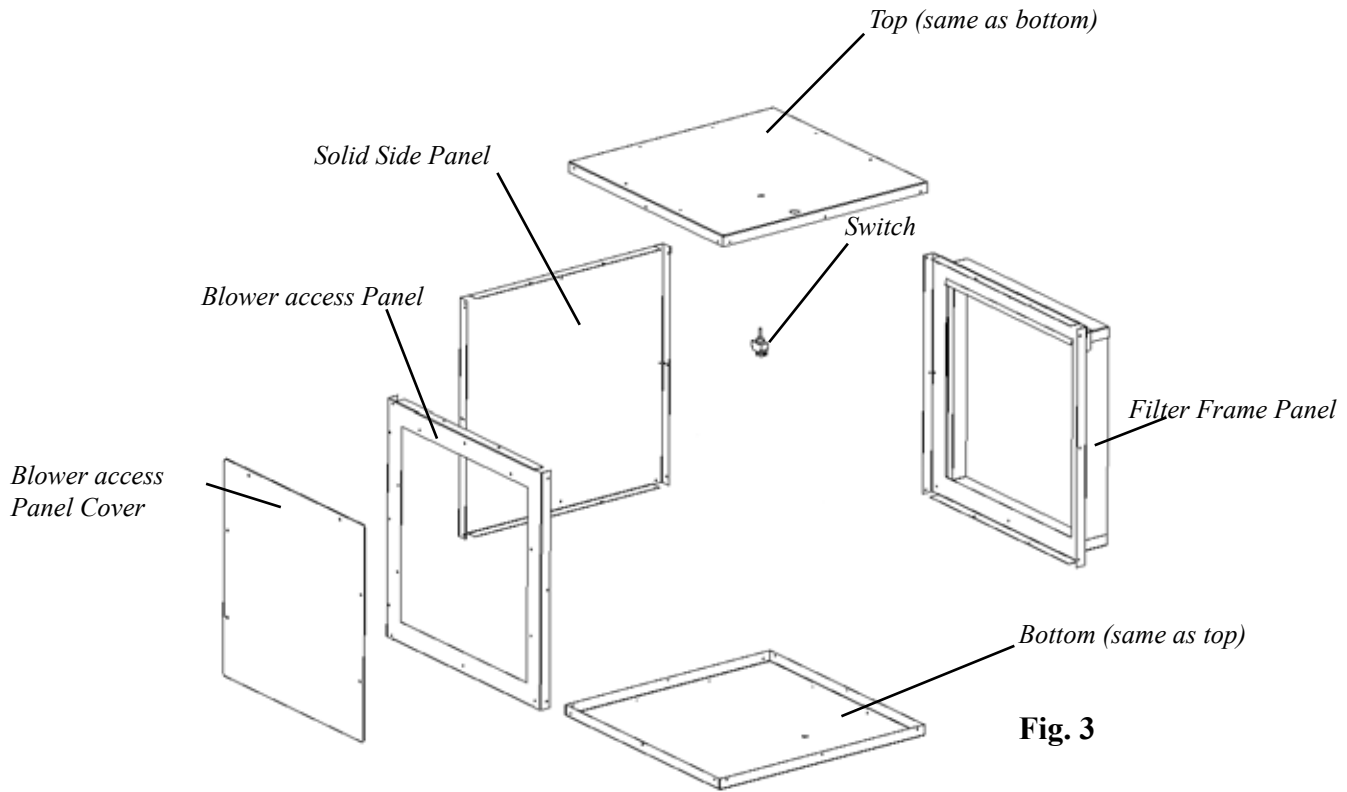

**Fig. 3**

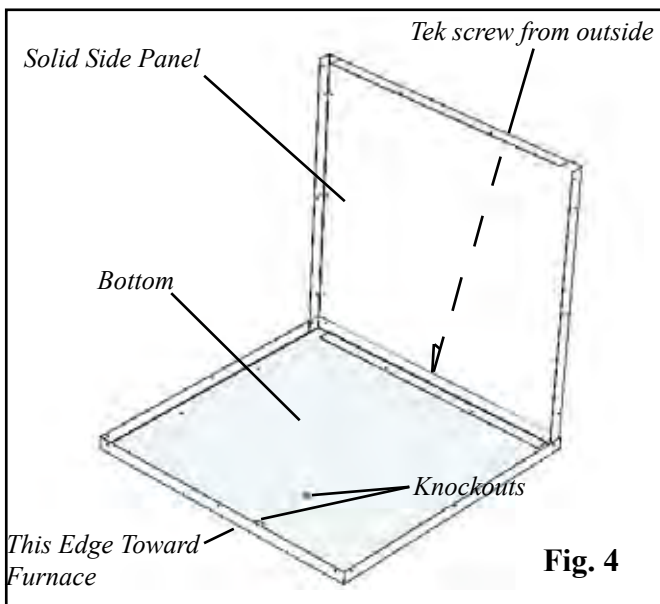

**Fig. 4**

### Assembling Filter Box

The cold air return filter box can be assembled with the filter frame on either side or the back, provided there is access to the combustion blower and flue area. It is not recommended that the filter frame be installed on the same side as the ash door due to the need to access the combustion blower, filter, and flue pipe for service.

1. Place the bottom on the floor. The edge closest to the knockouts will be the edge towards the furnace. See Fig. 4.
2. Place the desired vertical panel inside the bottom tray and hold into place with one Tek screw in the bottom middle hole. (solid panel shown) See Fig 4.

# Assembly

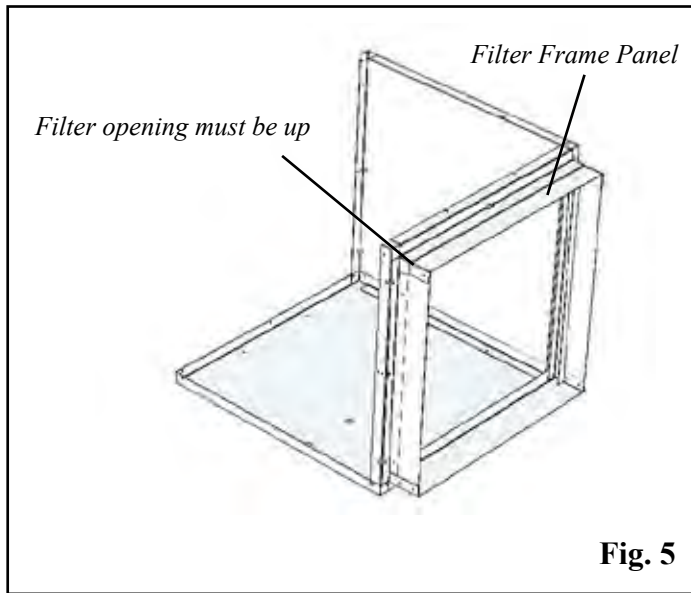

## Assembling Filter Box, Cont'd

3. Place the filter frame panel inside the bottom and inside the solid panel corner. See Fig. 6 for corner detail. Make sure that the filter opening is up. See Fig. 5 Hold the filter panel to the solid panel with a Tek screw in the middle hole of the solid panel, and one in the bottom middle hole under the filter opening.

NOTE: Do not put any screws into any of the top holes at this time.

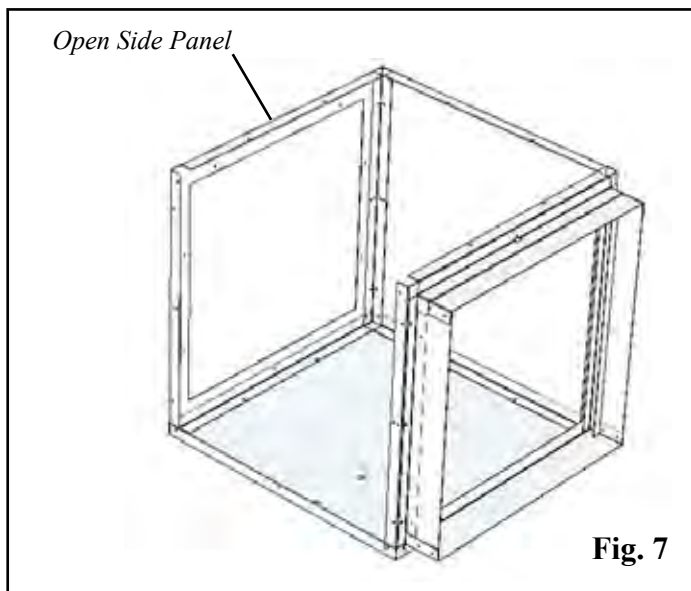
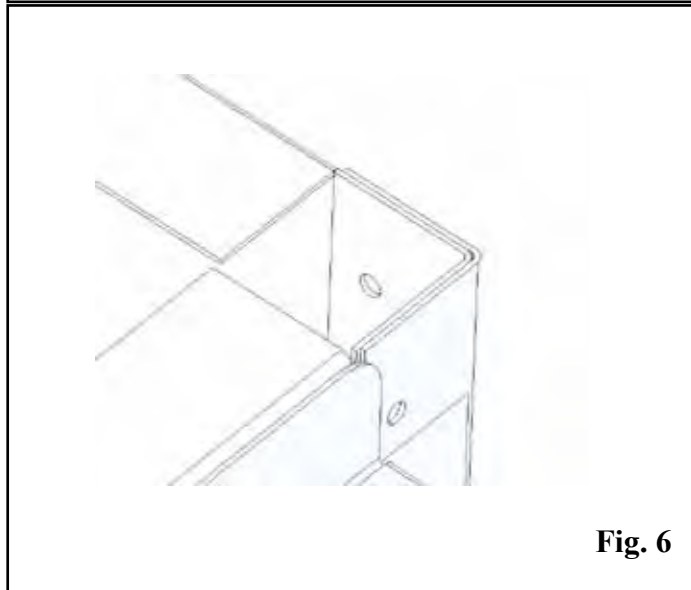

4. Place the remaining panel, (in this case the blower access panel) in the bottom panel and into the corner of the solid panel. See Fig. 7. Make sure that the panel is in the upright position. There are no cover mounting holes in the bottom edge of this panel. Hold the panel into place with one Tek screw in the middle hole of the solid panel and one in the bottom middle hole of the blower access panel.

# Assembly

## Assembling Filter Box, Cont'd

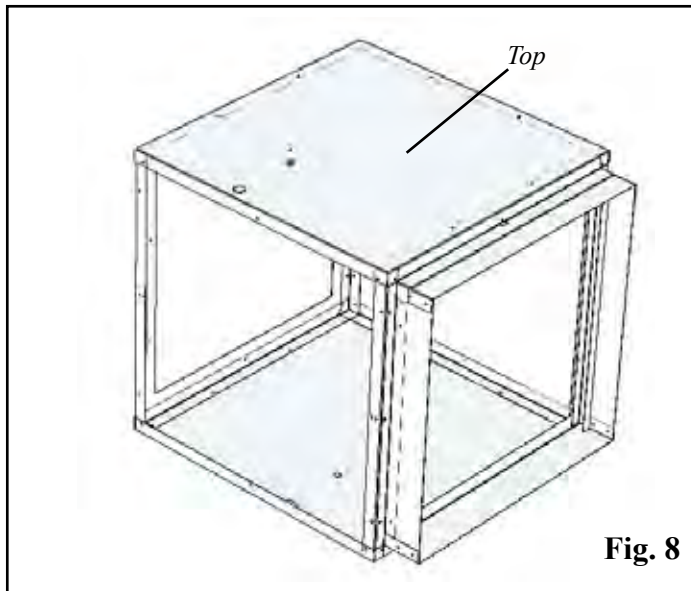

Fig. 8

5. Place the top on the filter box as shown in figure 8. At this time all Tek screws can be inserted around the filter box. **Note:** Except for the (6) screws that attach the blower access panel in place.

There should not be any screws protruding from the box on the side toward the furnace. Also DO NOT put a screw into the top center of the filter panel as a screw in this location will interfere with the filter access cover.

6. Pry out the two knockouts in the top of the box and install the flex connector and the switch. See Fig. 9.

**Note:** Don't forget the HI-MED-LO switch label on the switch before the locknut. Make sure that the setscrew on the flex connector is not pointing toward the furnace end of the box when the locknut is fully tightened. The filter box is now ready to install onto the furnace.

Follow the Blower mounting instructions on page 7 before continuing to step #7.

**Note:** The blower should be mounted on the furnace before the filter box for ease of distribution blower installation.

**Note:** It is best to wait until the blower, filter box, and cold air return duct work is installed before installing the filter and side panel.

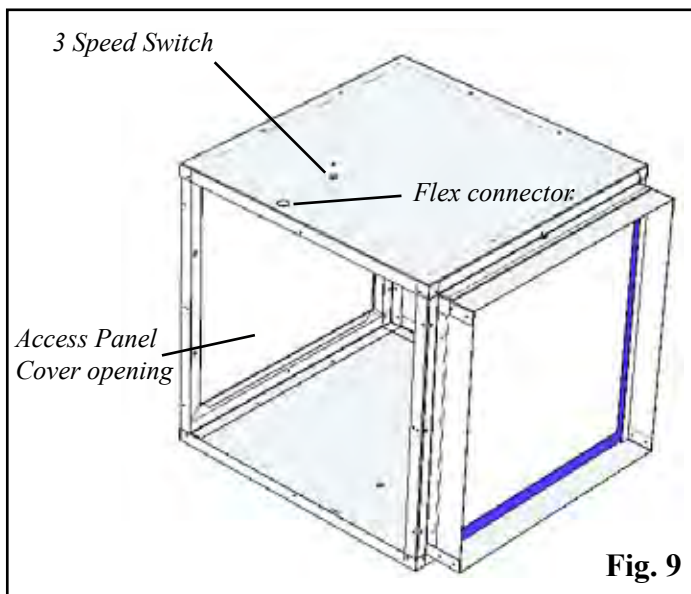

Fig. 9

7. After the Filter Box is installed on the furnace the electrical wiring to the three speed switch needs to be completed. White or Purple Neutral to White Neutral, Violet from the Fan Control to the center terminal of the switch, and the Black, Red, and Blue or Yellow to the terminals shown.

**Note:** The 1000 CFM blower is a 3-speed, and will wire as shown. The 1450 CFM blower is a single speed blower, therefore the three speed switch will not be used. The 1638 CFM blower is a 4 speed, only hook up the three colors shown and tape off the orange wire. See Fig. 10.

**(Note: the purple wire on the 1638 cfm blower is neutral, and gets spliced to the white neutral wire.)**

8. Install the access panel cover by hooking the lip at the bottom of the cover over the edge in the filter box. Use 6 Tek screws to secure the access panel.

9. To install the filter, insert the filter into the filter slot and slide completely into the frame. Take note to the air flow arrow on the filter when installing. Slide the filter access cover over the opening with the upright angle toward the filter box. If a Tek was put into the middle hole by mistake, remove the screw to allow the access cover to fit properly.

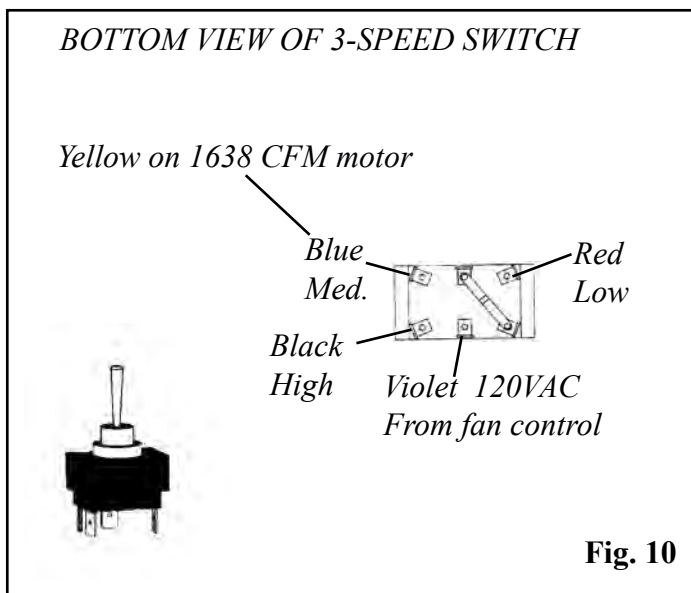
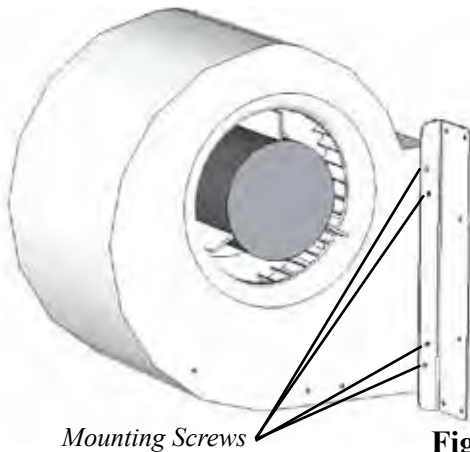

Fig. 10

# Assembly



Mounting Screws

Fig. 11

## Blower Assembly

Install the blower mounting brackets on the blower as shown in Fig. 11.

1. Install ( 4 ) Tek screws on each side where shown in Fig. 11. Start with the two center screws.

**NOTE:** There are two small holes in the discharge end of the blower that match the two center holes on the small angle of the blower bracket. The two (2) outer holes are drilled by the Tek screws.

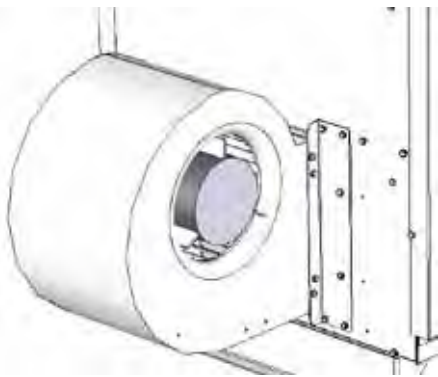

Fig. 12

2. Mount blower with brackets installed on the furnace as shown in Fig. 12. Each side will require 6 Tek screws.

**NOTE:** The furnace blower opening is made large enough for the use of any of the 3 offered blowers. The blower mounting brackets will fit either blower. The inner hole pattern is for the 1000 CFM blower and the outer pattern is for the 1450 or 1638 CFM blowers.

**NOTE: These Blower Motors are not designed to be operated without any positive static back pressure. OPERATION WITHOUT SUPPLY DUCTWORK OR IN FREE AIR WILL CAUSE MOTOR OVERLOAD AND PREMATURE FAILURE.**

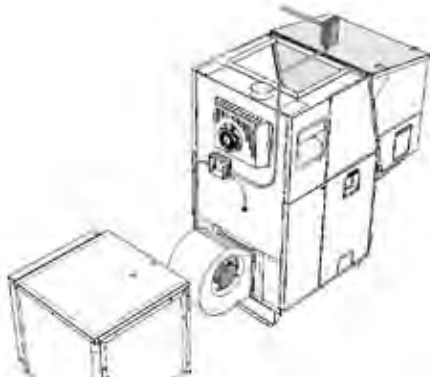

Fig. 13

**CAUTION:** Regardless of the supply air duct size installed, the Distribution Blower Motor **MUST** be checked for running Amperage. Check the motor name plate for the full load AMPS. If the amperage is running higher than that listed, a supply air restricting damper may be required to increase the supply plenum positive static pressure.

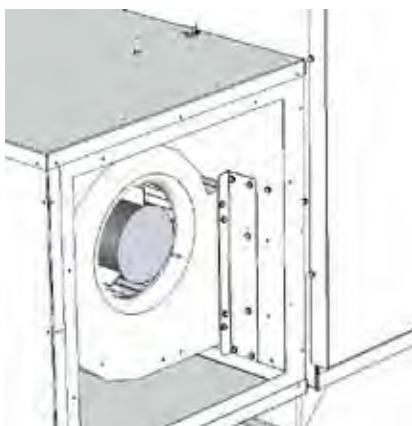
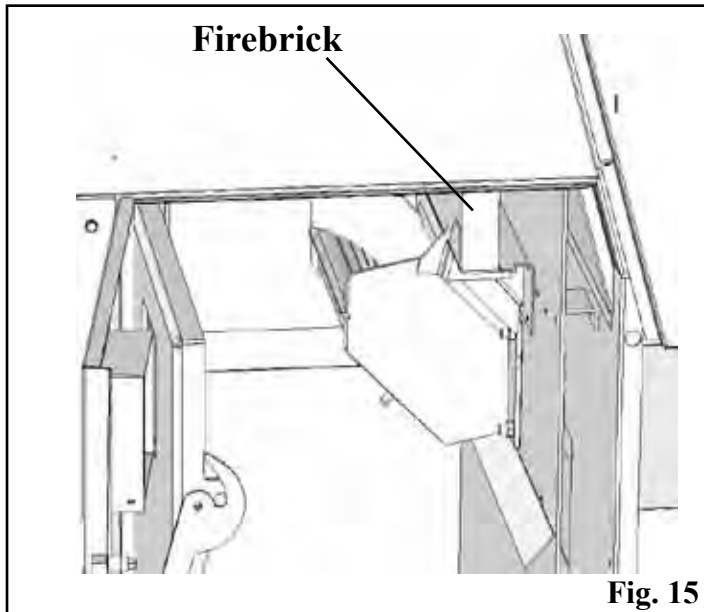

Fig. 14

3. Mount the filter box on the furnace with ( 6 ) #10 x 3/4 Tek screws, 3 on each side. Visually locate these holes so you are familiar with their location on the filter box and the furnace. Access to the mounting holes can be gained through the blower access panel cover and the filter opening. See Fig. 14.

**Note:** Two pieces of 2x4 stacked laying flat on the floor 12 inches from the blower opening will support the filter box during installation.

# Assembly



## Firebrick installation-required

The firebrick is shipped in the ash pan. It will need to be placed on the brick shelf as shown in Fig. 15. It can be installed with either face to the fire. Hold the brick longways and slide it down into the slot on the shelf. There is a stop at the rear of the shelf to stop the rearward travel. The brick just sits on the shelf in the upright position.

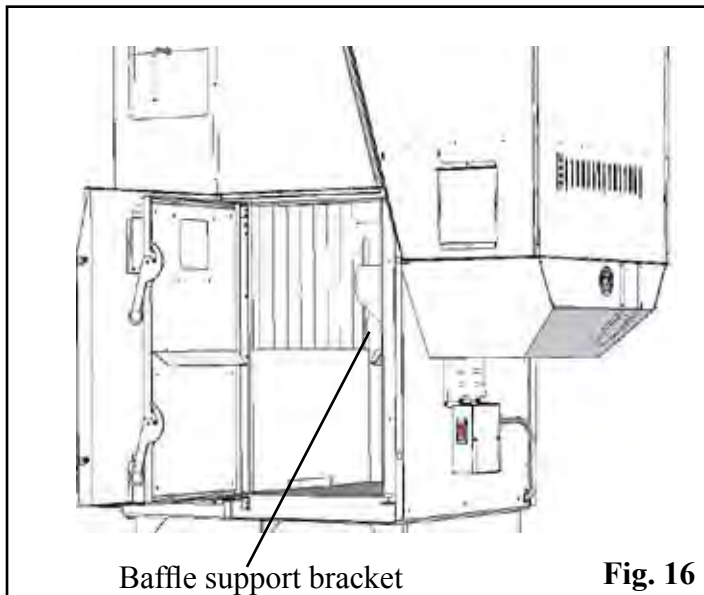

## Baffle installation

The upper heat exchanger baffle comes shipped along side the ashpan. Remove the ashpan and the baffle. This upper baffle needs to be installed before operating the furnace.

The baffle has a long 45 degree bend on the bottom of the firebox side. See Fig. 17.

On the opposite side there are four hooks that will support the baffle. On the front and rear of the firebox walls there are slots that these hooks fit into. See Fig. 16 Slide the upper baffle down to meet the slots, while you hold the baffle against the heat exchanger. You will notice that the upper baffle will hold the lower baffle plate into position. See Fig.17.

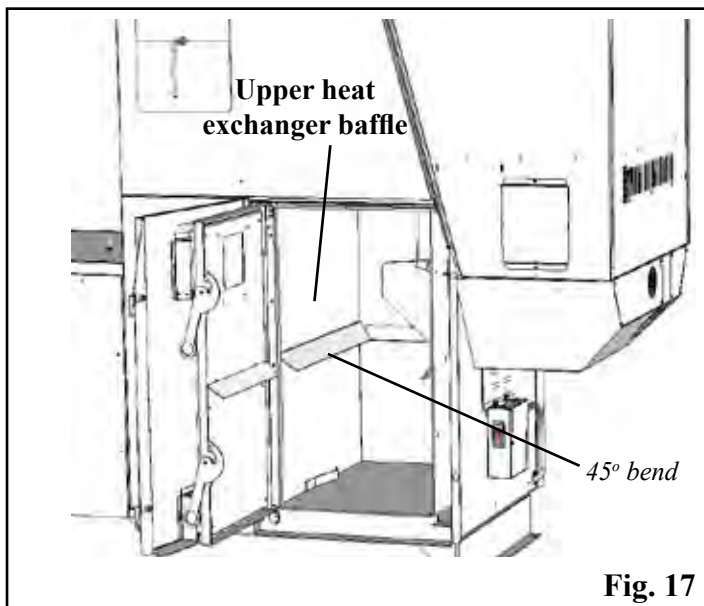

Note how the upper and lower baffles are held into position because they will need to be removed during heat exchanger cleaning.



# Installation

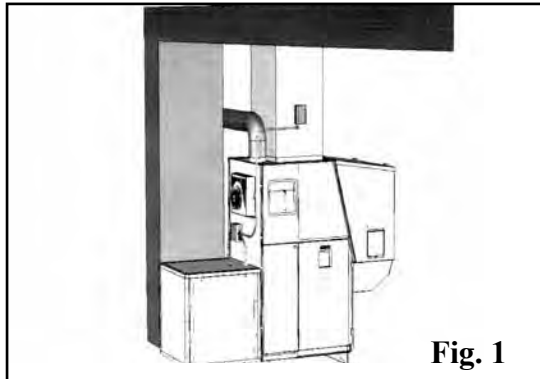

Fig. 1

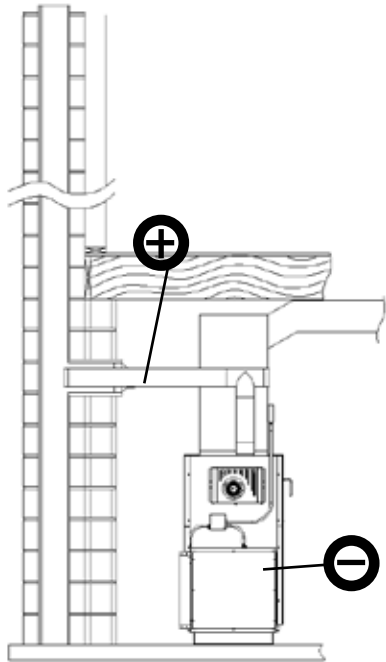
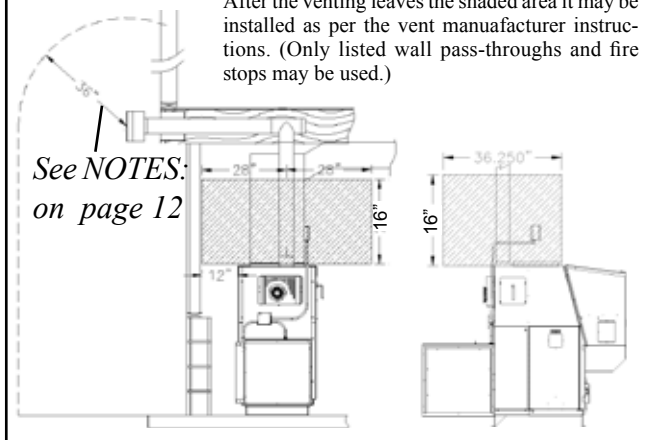

Fig. 2

## Clearances and Venting

The shaded areas where the clearances for the PL vent pipe must be maintained at 3". After the venting leaves the shaded area it may be installed as per the vent manufacturer instructions. (Only listed wall pass-throughs and fire stops may be used.)



**NOTE:** Read and follow all of the vent pipe manufacturers' instructions on the proper installation and support of the vent pipe. Adhere to all clearances.

## Design

The first thing needed is deciding where and how the furnace will be installed.

Things that need to be taken into consideration are Venting, Supply and Return Ducting, Electrical, and Condensation Drainage (if A/C is installed). Don't forget access to the furnace for service.

When the return air inlet position is known, the filter box and distribution blower can be installed. After the furnace is set into place, the venting can be completed.

## Venting

### Use 4" pellet vent pipe only.

A combustion blower is used to extract the combustion gases from the firebox. This creates a negative pressure in the firebox and a positive pressure in the venting system as shown in fig. 2. The longer the vent pipe and more elbows used in the system, the greater the flow resistance. Because of these facts, we recommend using as few elbows as possible and 30 feet or less of vent pipe. The maximum horizontal run should not exceed 18 feet. Remember, the horizontal pipe sections will accumulate with fly-ash first. Keep this area clean.

**Be sure to use wall and ceiling pass through fittings which are approved for pellet vent pipe when going through combustibles materials.** Be sure to use a starting collar to attach the venting system to the furnace. **The starting collar must be sealed to the furnace flue collar with high temp silicone caulking or aluminum tape, and screwed into the flue collar at least three (3) places.**

## Vent Pipe

4" pellet vent pipe (known as PL vent) is constructed of two layers with air space between the layers. This air space acts as an insulator and reduces the outside surface temperature to allow a clearance to combustibles as low as 2 inches. This clearance is tested and listed by the pipe manufacturers.

The sections of pipe lock together to form an air tight seal in most cases; however, in some cases a perfect seal is not achieved. For this reason and the fact that the furnace operates with a positive vent pressure, **we specify that all joints within the structure should also be sealed with high-temp silicone.**

**NOTE:** Use only 4" diameter "PL" venting system. Be sure to inspect and clean exhaust venting system frequently.

# Venting

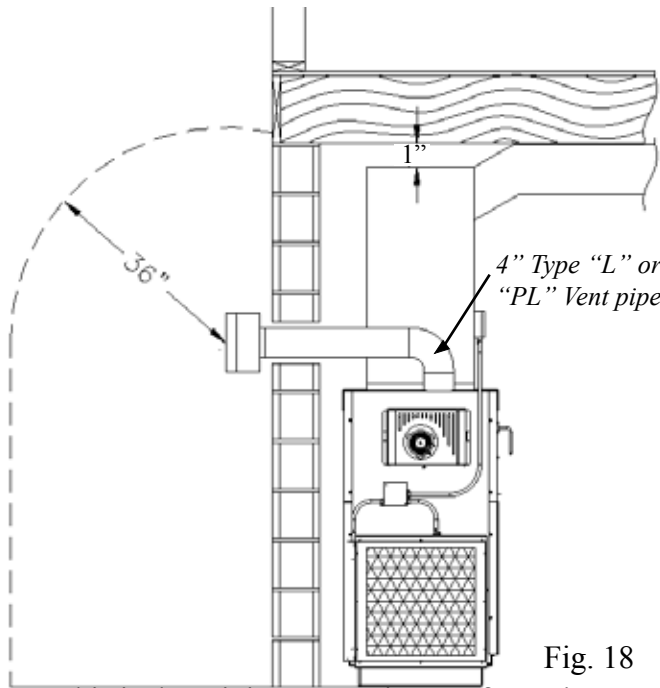

Fig. 18

This is the minimum venting configuration.

NOTE: This would only be allowed with **non-combustible** walls.

The minimum vent configuration is a 90° or Tee on a starter collar and a 24" length horizontal through an exterior wall. A cap or other bird screen on the end should direct the flue gasses down and away from the structure. See Fig. 18.

The maximum horizontal length is 18 feet. The minimum termination height above the exterior grade is 18". The maximum total length of any configuration is 30 feet\*. \* ( see venting graph on page 11)

NOTE: Cleanout Tee's should always be used on the transitions to horizontal pipe to allow easy access for cleaning.

The venting graph allows for (one) 90 deg. or Tee fitting in any configuration.

If more 90's, T's, or 45's are needed the total length must be adjusted to allow for the added restriction.

Up to four (4) additional 90's, Tee's, or equivalent 45's can be added as long as the overall length is adjusted in accordance with the values listed below.

( See the venting graph on page 11.)

Each Vertical ---- 90 deg. or T subtract 2.5 feet

Each Vertical ---- 45 deg. subtract 1.5 feet

Each Horizontal - 90 deg. or T subtract 5.0 feet

Each Horizontal - 45 deg. subtract 2.5 feet

**Any exterior venting (vent pipe exposed to outside ambient temperatures) should be kept to a minimum, due to potential condensation problems.**

This is especially important in high humidity cold weather climates, such as maritime areas, lake shores, and low river valleys.

**NOTE: Use only 4" diameter "PL" venting system. Be sure to inspect and clean exhaust venting system frequently.**

**INSTALLATION IS TO BE PERFORMED BY A QUALIFIED INSTALLER.**

**DO NOT INSTALL A FLUE DAMPER IN THE EXHAUST VENTING SYSTEM OF THIS UNIT.**

**DO NOT CONNECT THIS UNIT TO A CHIMNEY FLUE SERVING ANOTHER APPLIANCE.**

**INSTALL VENT WALL PASS-THROUGHS AT CLEARANCES SPECIFIED BY THE VENT MANUFACTURER.**

**NOTE: All installation clearances and restrictions must be adhered to.**

**NOTE: Read and follow all of the vent pipe manufacturers' instructions on the proper installation and support of the vent pipe. Adhere to all clearances.**

## WARNING

**KEEP COMBUSTIBLE MATERIALS SUCH AS GRASS, LEAVES, ETC. AT LEAST 3 FEET AWAY FROM THE POINT DIRECTLY UNDER THE VENT TERMINATION. (BETWEEN THE VENT AND THE GROUND)**

## CAUTION

**KEEP COMBUSTIBLES AWAY FROM FLUE OUTLET.**

## Venting Configuration Graph

Fig. 19

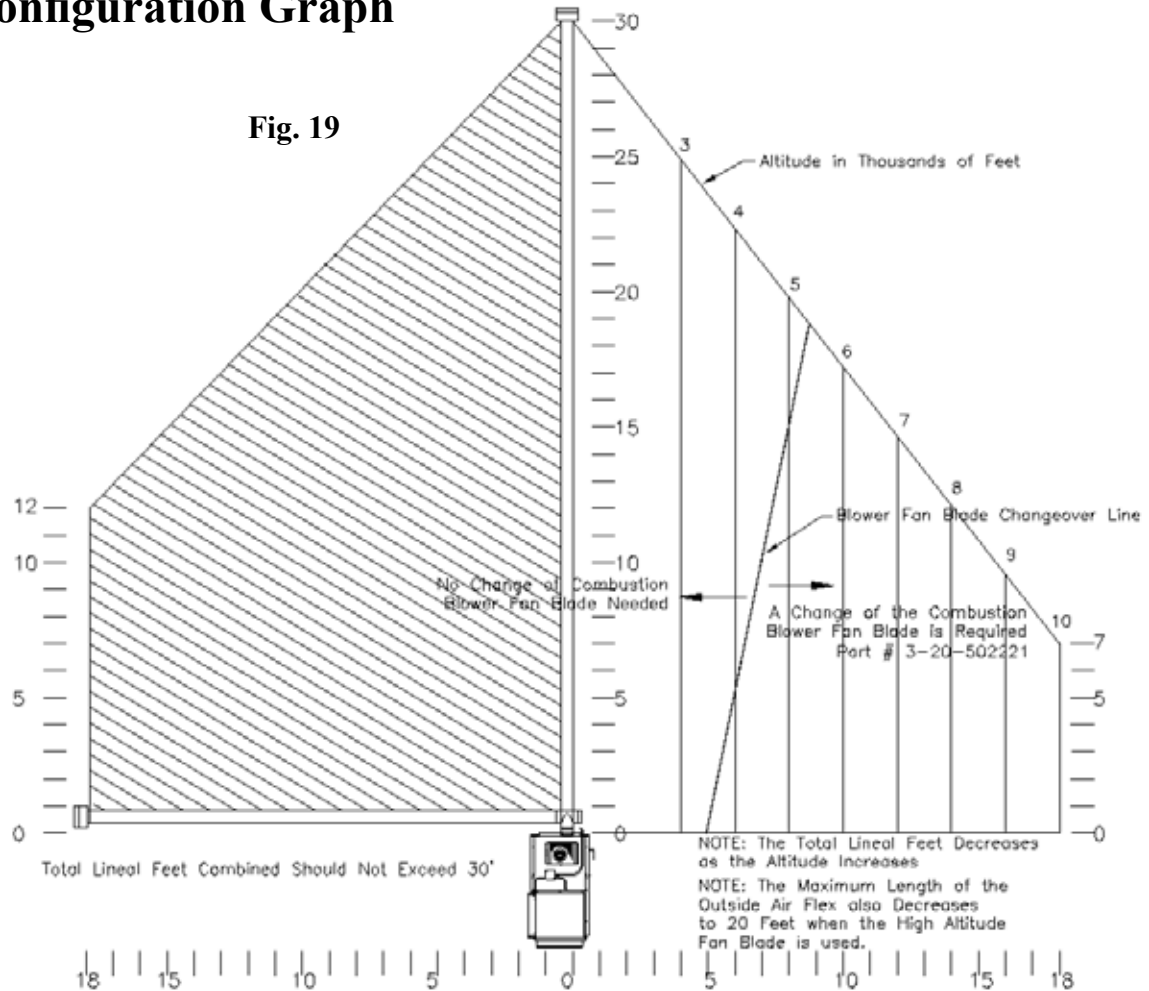

**To reduce probability of reverse drafting during a power failure, Hearth & Home Technologies strongly recommends:**

- Installing the pellet vent with a minimum vertical rise of five feet. Preferably terminating above the roof line.

- Installing an outside air connection to the appliance.

**To prevent soot damage to exterior walls, and to prevent re-entry of soot or ash into the home:**

- Maintain specified clearances to windows, doors and air inlets, including air conditioners.

- Vents should not be placed below ventilated soffits.

- Avoid venting into alcove locations.

- Vents should not terminate under overhangs, decks or onto covered porches.

- Maintain minimum clearance of 12" from the vent termination to the exterior wall.

**Hearth & Home Technologies assumes no responsibility for, nor does the warranty extend to, smoke damage caused by reverse drafting of pellet appliances under power failure conditions.**

Hearth & Home Technologies strongly recommends the use of outside air for all pellet furnace applications.

Per national building codes, consideration must be given to combustion air supply for all appliances in the vicinity of the pellet boiler. Failure to supply adequate combustion air for all appliance demands may lead to backdrafting of those appliances. Consult with your HVAC Professional to determine that all combustion air requirements are met.

**When the appliance is side-wall vented:** The air intake is best located on the same exterior wall as, and lower than the exhaust vent outlet.

**When the appliance is roof vented:** The air intake is best located on the exterior wall oriented towards the prevailing wind direction, during the heating season.

# Venting

## Requirements for Terminating the Venting

**WARNING:** Venting terminals must not be recessed into a wall or siding.

**NOTE:** Only PL vent pipe wall pass-throughs and fire stops should be used when venting through combustible materials.

**NOTE:** Always take into consideration the effect the prevailing wind direction or other wind currents will cause with flyash and /or smoke when placing the termination.

### In addition, the following must be observed:

- A. The clearance above grade must be a minimum of 18".<sup>1</sup>
- B. The clearance to a window or door that may be opened must be a minimum of 48" to the side, 48" below the window/door, and 12" above the window/door.<sup>1</sup>
- C. A 12" clearance to a permanently closed window is recommended to prevent condensation on the window.
- D. The vertical clearance to a ventilated soffit located above the terminal within a horizontal distance of 2 feet (60 cm) from the center-line of the terminal must be a minimum of 18".
- E. The clearance to an unventilated soffit must be a minimum of 12".
- F. The clearance to an outside corner is 11" from center of pipe.
- G. The clearance to an inside corner is 12".

H. A vent must not be installed within 3 feet (90 cm) above a gas meter/regulator assembly when measured from the horizontal center-line of the regulator.<sup>1</sup>

I. The clearance to service regulator vent outlet must be a minimum of 6 feet.<sup>1</sup>

J. The clearance to a non-mechanical air supply inlet to the building or the combustion air inlet to any other appliance must be a minimum of 48".<sup>1</sup>

K. The clearance to a mechanical air supply inlet must be a minimum of 10 feet.<sup>1</sup>

L. The clearance above a paved sidewalk or a paved driveway located on public property must be a minimum of 7 feet.<sup>1,2</sup>

M. The clearance under a veranda, porch, deck or balcony must be a minimum of 12 inches.<sup>1,3</sup> (see B also)

**NOTE:** The clearance to vegetation and other exterior combustibles such as mulch is 36" as measured from the center of the outlet or cap. This 36" radius continues to grade or a minimum of 7 feet below the outlet.

<sup>1</sup>Certain Canadian and or Local codes or regulations may require different clearances.

<sup>2</sup>A vent shall not terminate directly above a sidewalk or paved driveway which is located between two single family dwellings and serves both dwellings.

<sup>3</sup>Only permitted if veranda, porch, deck, or balcony is fully open on a minimum of 2 sides beneath the floor.

**NOTE:** Where passage through a wall, or partition of combustible construction is desired, the installation shall conform to CAN/CSA-B365. (if in Canada)

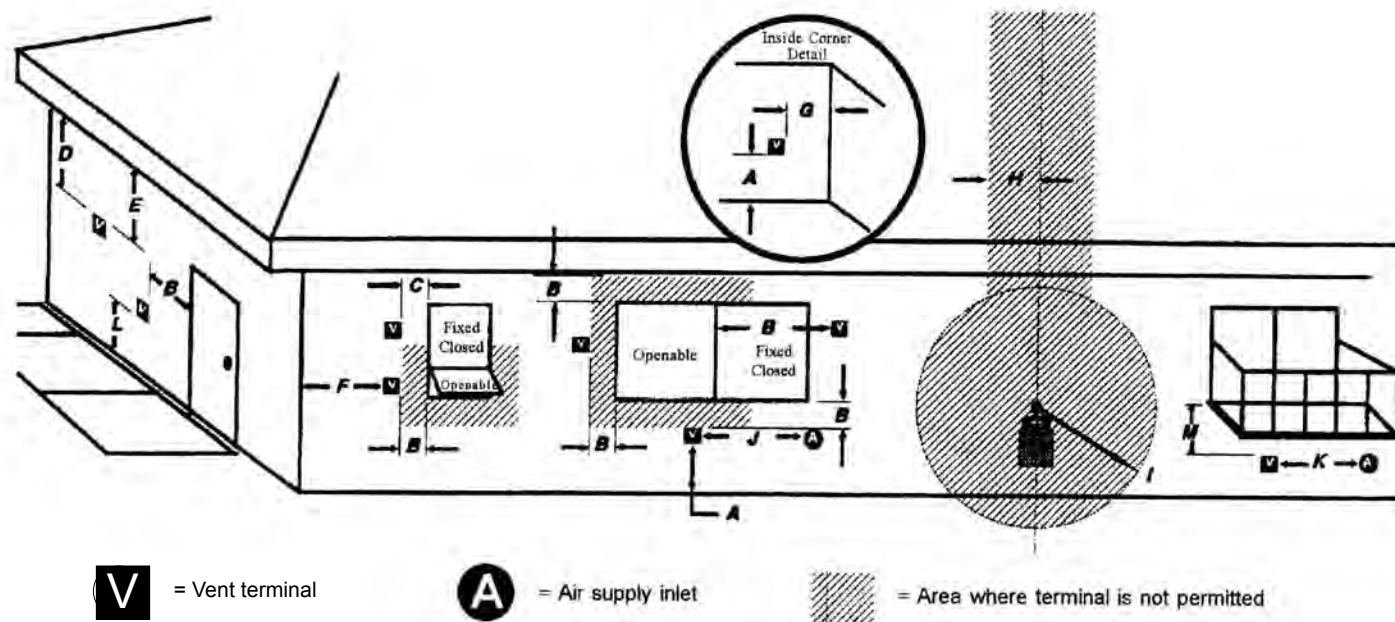

# Venting and Clearances

## Clearances to combustibles

If installing the furnace in a room separated from the remaining living spaces, the minimum size of the room must be no smaller than 8' x 8'. See Fig. 21. The reason for this is heat build-up and required space for service and normal operation. This is the minimum size of the room even if it is built of non-combustible material.

High and low air vents **MUST** be installed between the room and the remaining living space. Each vent should be at least 72 square inches in area. (The vent size will need to be increased if there is no return air ducting system.)

The striped areas are the minimum clearances to combustibles which is 36" from stove body, not the hopper or blower.

The shaded area indicates the required floor protection area. The furnace requires 48" x 52" of floor protection centered around the skidplate footprint. Flooring should be a minimum of 26 gauge sheet metal covering the installation clearance area and 18" in front of, and 8" to either side of the ash pan door.

The 18" clearance from the hopper end is a manufacturer's recommendation for adding pellets and/or servicing the feeder mechanism.

The minimum clearance to the top of the plenum is 1".

Note the minimum height to the bottom of the supply duct if it crosses the hopper.

The minimum duct configuration to a living space above the furnace is as shown below. An offset of at least 24" **MUST** be installed between the plenum and the floor register. The register size **MUST** have an area of at least 240 square inches.

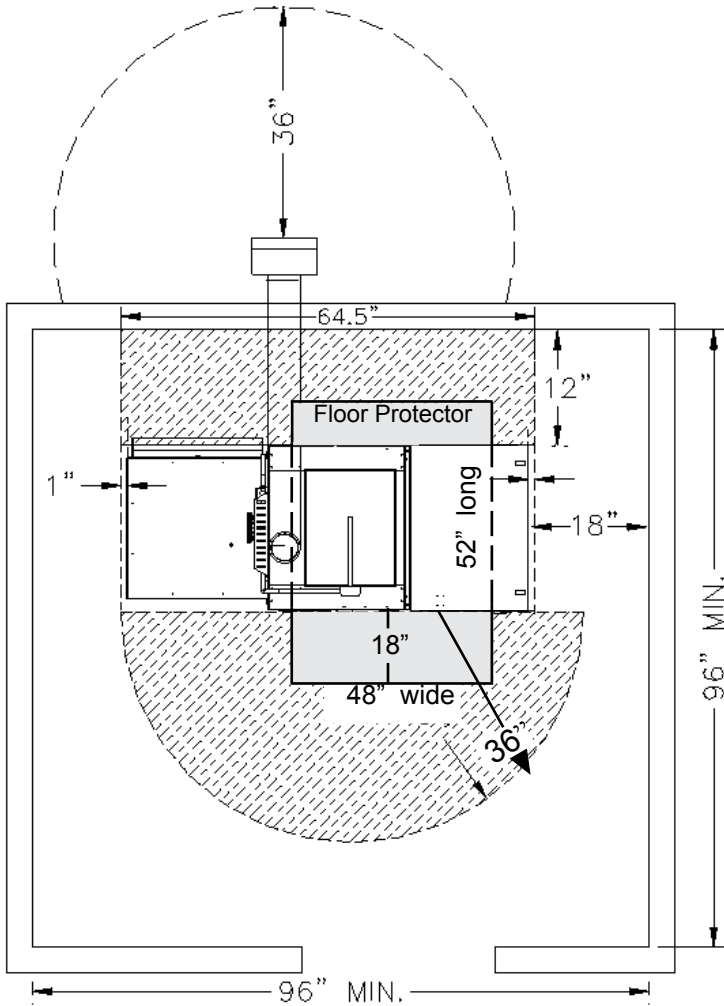

Fig. 21

The minimum ceiling height is 6'6". This is set by the clearance to combustibles (28") from the top of the of the furnace. See Fig. 22.

**NOTE:** Install vent at clearances specified by the vent manufacturer.

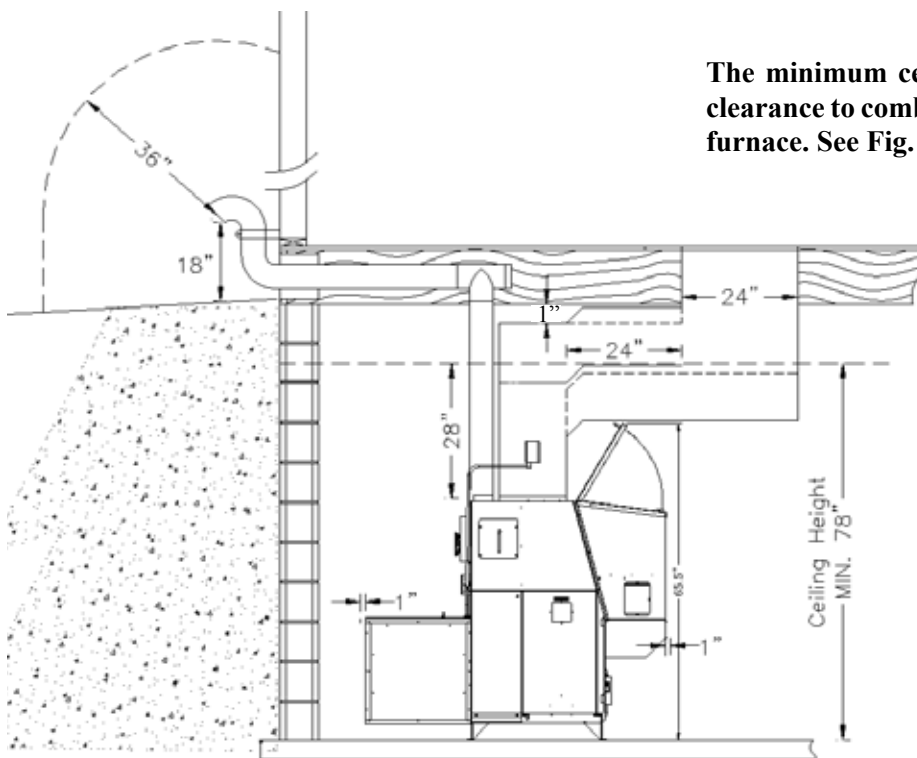
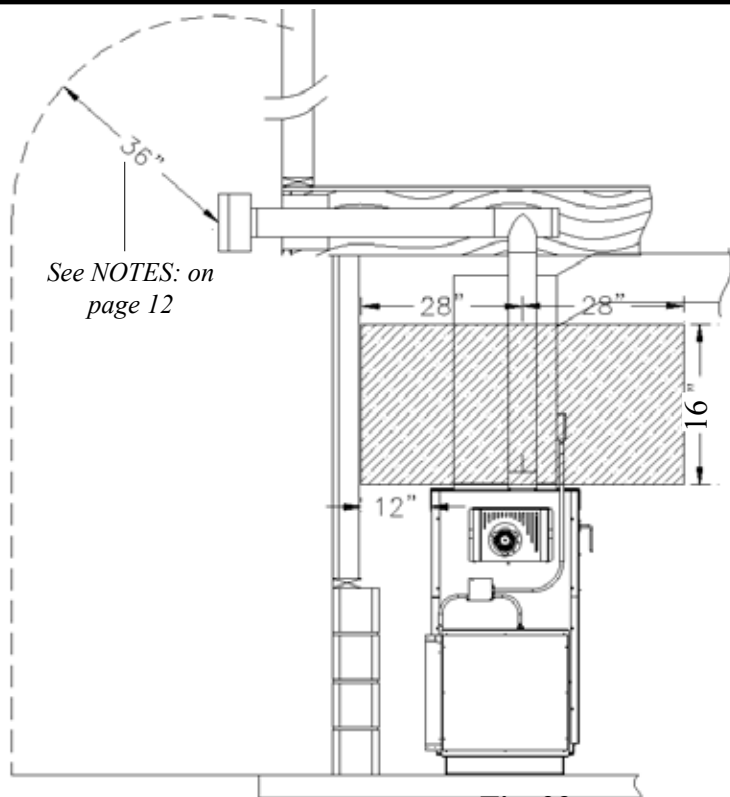

Fig. 22

**CAUTION:** When installing a floor register, the temperature of the discharge air **MUST** be taken into consideration (The discharge air temperature may be high enough to cause burns if not properly operated and maintained.)

**CAUTION:** The Blower Motor full load AMPS **MUST** be checked. A plenum damper may be required to adjust the motor full load AMPS to the motor nameplate rating.

# Venting and Installation



**Fig. 23**

The shaded area is where the clearance for the PL vent pipe must be maintained at 3". After the venting leaves the shaded area it may be installed as per the vent manufacturer instructions. (Only listed 4" pellet vent wall pass-throughs and fire stops may be used.) See Fig. 23 & 25.

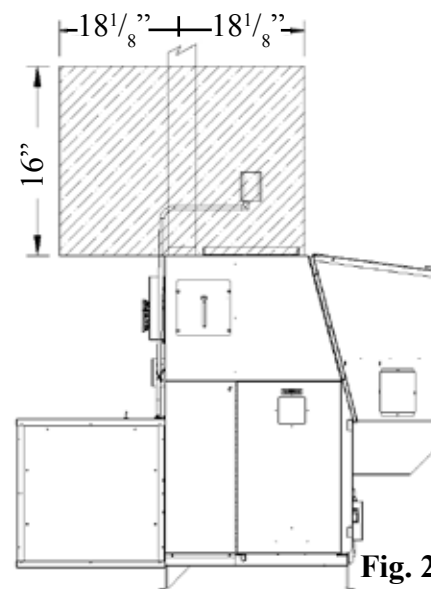

**Fig. 25**

Chimneys taller than 20' above the connection will require a draft test to determine if the draft is too high.

Note: The High Burn Draft should not exceed .85 IWC. Some form of a restrictor plate may be required at the top of high chimneys to reduce the draft. See page 20 for the Draft Test procedure.

This furnace may be used and installed into an existing masonry or Class A metal chimney.

**Certain Canadian and Local Codes may require that the chimney be fully relined. See Fig. 24.**

**This Furnace May Not** be vented into a chimney flue serving another appliance.

The chimney should be cleaned and or inspected before installation.

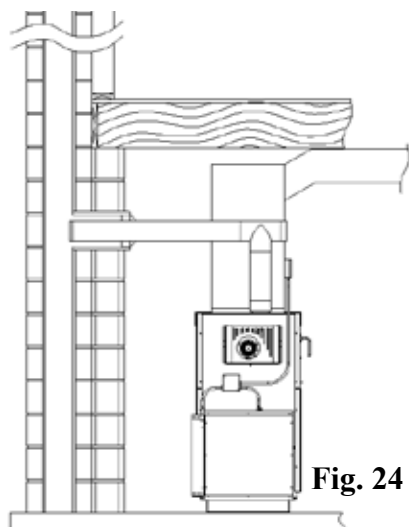

**Fig. 24**

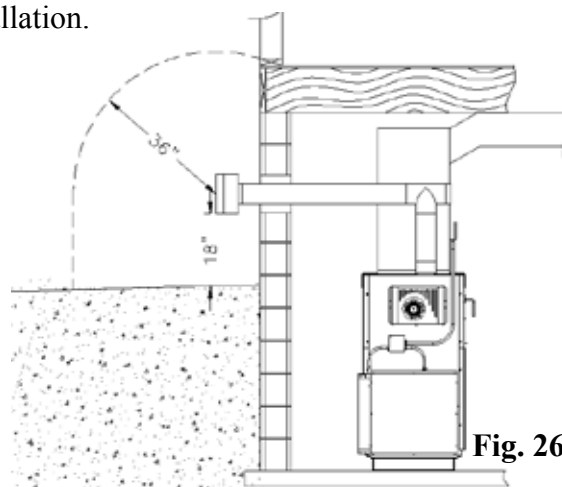

**Fig. 26**

**Creosote - Formation and Need for Removal** - When wood is burned slowly, it produces tar and other organic vapors, which combine with expelled moisture to form creosote. The creosote vapors condense in the relatively cool chimney flue of a slow-burning fire. As a result, creosote residue accumulates on the flue lining. When ignited, this creosote makes an extremely hot fire. The pellet vent pipe should be inspected at least twice monthly during the heating season to determine if a creosote buildup has occurred. If creosote has accumulated it should be removed to reduce the risk of a chimney fire.

Guidance on minimizing creosote formation and the need for periodic creosote removal: The chimney should be inspected during the heating season to determine if a creosote build-up has occurred. If a significant layer of creosote has accumulated (3mm or more) it should be removed to reduce the risk of a chimney fire.

# Installation

## Outside Air

The use of outside air is optional. Connecting to outside air may be required by local codes, and is strongly recommended. To install outside air, use 2 $\frac{3}{4}$ " I.D. metal flex pipe, part # 2-00-08544 (12'6" length) or part #2-00-08545 (25' length). There is a break-away hole on the rear panel which must be removed before connecting the flex pipe. See Fig. 28. The pipe should be run outside and terminate 3 feet or more below or 1 foot or more to the side of the vent pipe outlet. Never terminate the outside air above the vent pipe outlet. The maximum length of this pipe is 25 feet. Inlet cover, part #1-10-09542 should be used to keep birds, rodents etc. out of the inlet pipe. See Fig. 27.

**NOTE:** If outside air is installed, the inlet cover should not be placed in an area where drifting of snow or ice will build up, blocking the intake air supply.

Only metal Intake Flex should be used for the Outside Air Supply connection.

Only a screened or rodent protected Outside Air Intake cover should be used as an outside weather cover.

The Outside Air Intake Pipe is inside the Feeder Cover and to the right of the feeder motor. The 2 $\frac{3}{4}$ " steel flex pipe is made to slide over the outside of the Air Intake Pipe. See Fig. 29. It should be held into place with some silicone, foil tape, or a hose clamp. (not supplied)

Heat rises in the house and leaks out at upper levels. This air must be replaced with cold air from outdoors which flows into lower levels of the house. Vents and chimneys into basements and lower levels can become the conduit for air supply and reverse under these conditions.

The outside air supply will supply most of the demands of the pellet appliance to resist back-drafting, but consideration must be given to the total house demand. It may be necessary to add additional ventilation to the space in which the pellet appliance is located. Consult with your HVAC professional to determine the ventilation demands for your house.

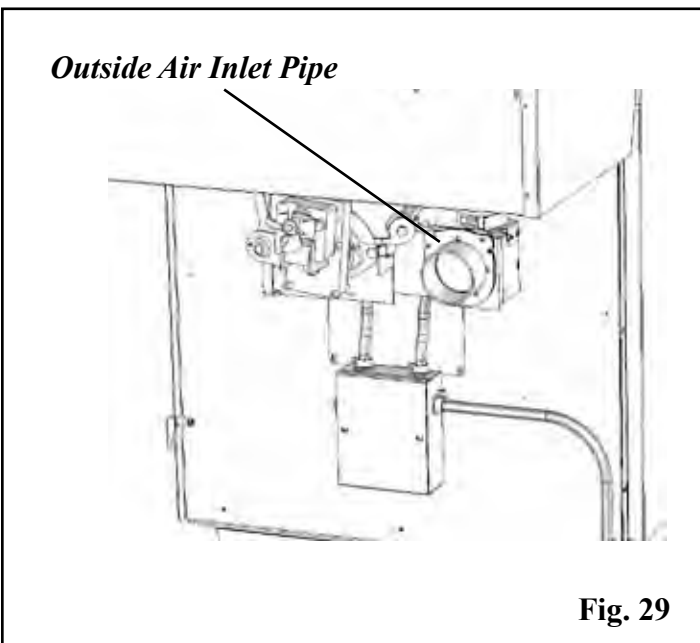
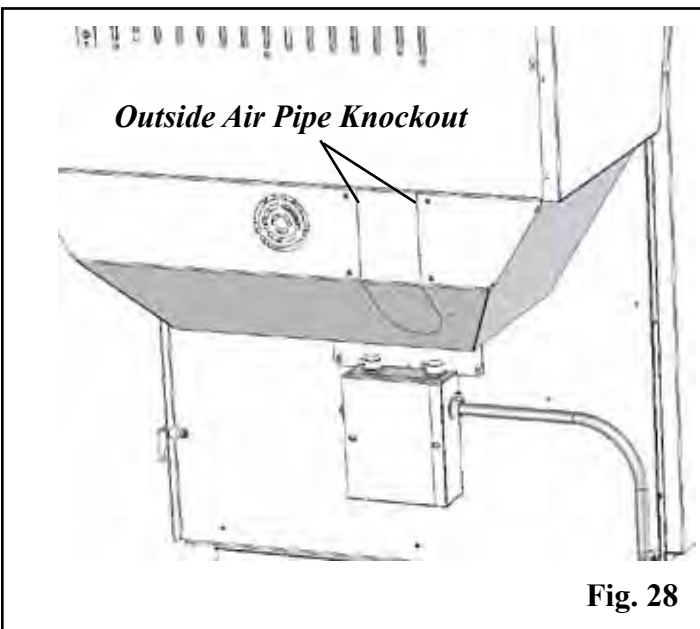
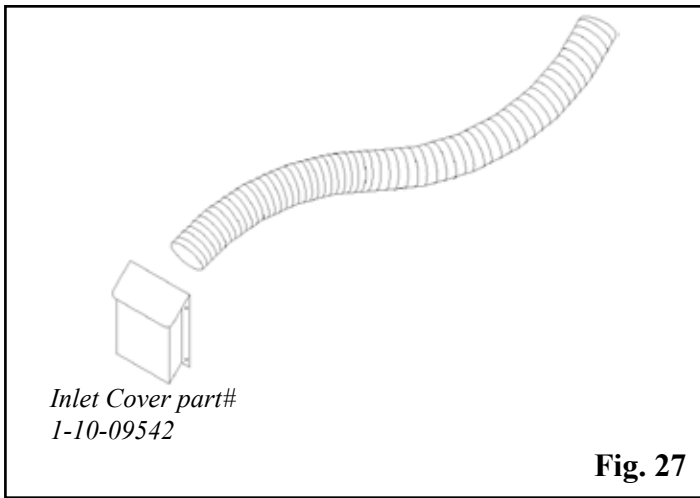

# Installation

## Wall Control Wiring

The Wall Control sends and receives information from the control board through a 4 wire Datacom cable. There is a 100' length of this cable supplied with the furnace. 100' lengths of this cable can also be ordered separately, part #3-20-02583. Alternately, any Datacom cable - CAT3- 2 twisted pair 24ga solid wire can be acquired at a local electrical supply house. Also any CAT3-24ga. solid wire 2, 3, or 4 pair cable can be used because they all have the same pair color combinations. The maximum length of wall control wiring is 100 feet.

The furnace connecting point is a 4 pole screw terminal block on the side of the hopper just around the corner to the right of the control. Follow the wiring instructions on the label alongside the terminal block. See Fig. 31.

**CAUTION:** With this small gauge of wire, care must be taken not to overtighten the terminal screws thus, breaking the wire.

There are tie-wrap holes in the face of the hopper approx. every 6" to keep the cable secure and out of the way.

The Wall Control is made to fit on a standard wall case electrical box. It could also be mounted directly to a stud using 2 drywall screws. In either case the screws should be turned in and tested for a snug fit when the Wall Control is slid down over the screws. The Wall Control only hangs on the screws so a good fit is important.

Remove the Wall Control and make the Datacom cable connections with the UY auto splicers provided. **DO NOT STRIP THE WIRES.** Following the wiring diagram on the inside of the Wall Control make each splice. See Fig. 32. Insert the two matching color wires fully into the two holes of one of the UY connectors. A pair of standard Channel-lock pliers works ideally to squeeze the raised button down into the UY connector body. Extra UY connectors can be purchased. Part # 3-20-00200

**NOTE:** A pair of needle nose pliers may be helpful to insert the BLUE T-stat wires fully into the connector. Visually inspect to see that the wires are fully inserted before squeezing the UY splicer.

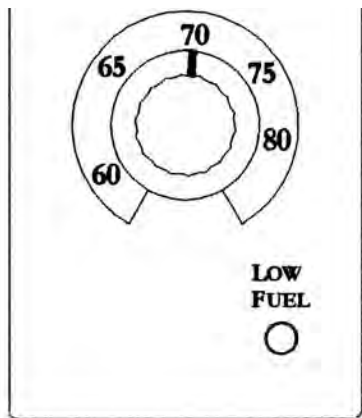

Fig. 30

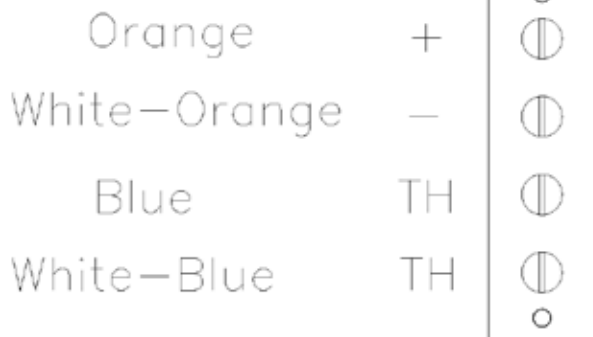

Fig. 31

Datacom Cable	Wall Control	
Orange -	Red	(+ LED )
Blue/White -	Blue	( Tstat )
Orange/White -	White or Black	( - LED )
Blue -	Blue	( Tstat )

Fig. 32



# Installation

## Mobile Home Installation

This furnace may be installed in a manufactured / mobile home. The following specific requirements must be met;

1. The furnace must be hooked up to an outside air source.(see page 15)
2. The furnace must be secured or bolted to the floor of the mobile home. Use lag bolts through the provided holes (see below).

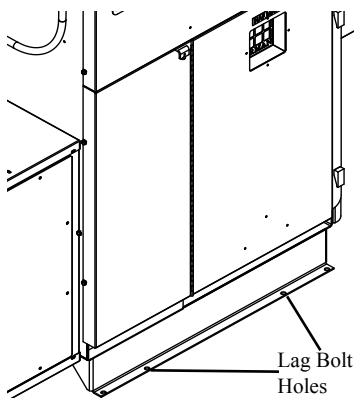

3. The furnace must be grounded to the frame of the mobile home.

4. Floor protection and clearance specifications must be followed, including the minimum room size of 8 feet by 8 feet.

5. As in any installation, the furnace must be vented to the outside, using only approved 4 inch pellet venting materials.
6. The furnace can not be installed in a room specified as a sleeping room.

**Mobile home installation must be done in accordance with the Manufactured Home and Safety Standard (HUD), CFR 3280, Part 24.**

### WARNING

**IN A MOBILE / MANUFACTURED HOME;  
DO NOT INSTALL IN SLEEPING ROOM**

### CAUTION

**THE STRUCTURAL INTEGRITY OF THE  
MANUFACTURED HOME'S FLOOR,  
WALLS, AND CEILING / ROOF MUST BE  
MAINTAINED.**

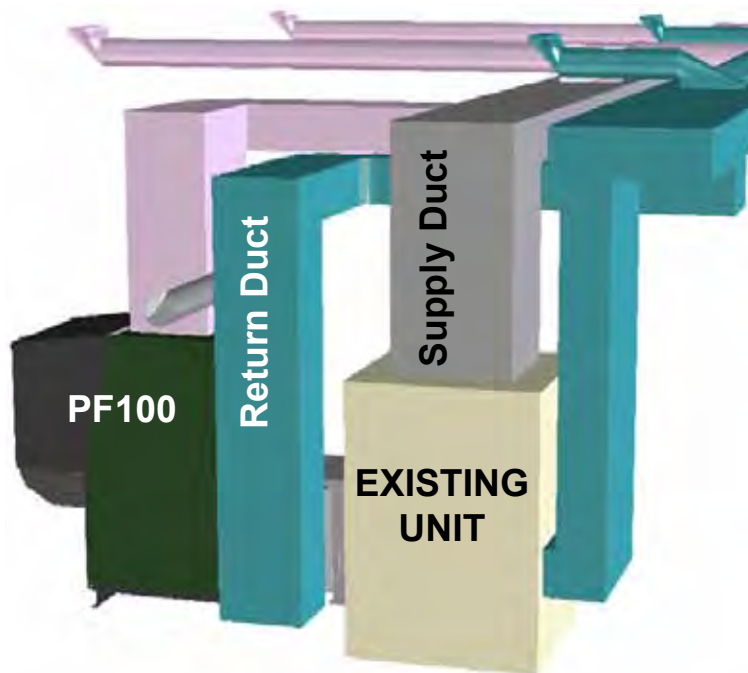

Fig. 33

## Installing Duct

The pellet furnace may be connected to a gas or oil-fired central furnace or heat pump duct system. Prior to installation, determine whether all requirements for installation including all clearances can be met.

The pellet furnace warm air supply and the cold air return must be installed in a parallel arrangement. EXAMPLE: The warm air supply duct from the pellet furnace is to be connected to the warm air supply of the existing furnace. Also the cold air return duct from the existing furnace is to be connected to the cold air return duct of the pellet furnace. Isolation dampers (2) should be installed in the ductwork. (1) in the warm air supply duct for the existing furnace and (1) in the warm air supply duct of the pellet furnace after or “downstream” of the high limit/fan control. These dampers can be manually operated or fully automatic. In either case, the unit that is not being used must be prevented from being operated. (This also can be done manually or automatically.) NOTE: Any control wiring, power wiring needed should be performed by a qualified installer and/or electrician.

The warm-air supply outlet of the pellet furnace shall not be connected to the cold-air return inlet of the existing furnace because of the possibility of overheating components of the existing furnace, causing the existing furnace to operate other than as intended.

We recommend that the warm air supply plenum be constructed of sheet metal.

# Installing Duct

## Recommendations for Supply Air and Return Air duct sizing.

The speed or velocity of air moving through duct systems increases as the duct decreases in size with the same CFM blower. The sound of air flowing through the duct increases as the velocity increases. Therefore the largest duct size practical should be used.

The velocity to sound level must be taken into consideration when connecting this furnace into an existing duct system.

As a primary source furnace the duct system can be installed to fit the customers needs.

These are recommended Supply Air duct sizes (in square inches) for some of the different CFM blowers that may be used with this furnace.

Velocity	500fpm	700fpm	900fpm
Static-In. W.C.	.3	Minimum to .6	Maximum
1000 cfm.	270 in <sup>2</sup>	210 in <sup>2</sup>	160 in <sup>2</sup>
1450 cfm	360 in <sup>2</sup>	290 in <sup>2</sup>	220 in <sup>2</sup>
1638 cfm	470 in <sup>2</sup>	360 in <sup>2</sup>	290 in <sup>2</sup>

(These duct sizes are only recommendations. )

The Return Air duct system should be sized approximately 10 percent larger for heating only systems and 20 percent larger if air conditioning is installed.

## Adding Air Conditioning to the pellet furnace.

An easy rule of thumb for A/C CFM blower size is, .75 to 1 CFM for each square foot of conditioned space. (std. 8' ceiling height )

This furnace can be fitted with an air conditioning coil mounted in the supply air plenum.

HHT is not responsible for sizing, duct placement, or interconnections. However we have made adding A/C to the furnace easier with the information listed below.

There is a factory installed junction box ready to accept your A/C relay. The A/C fan control center with 40 va transformer must have a DPDT relay. White Rodgers # 90-112, part # 3-20-38056 is available. Other brands are also acceptable for use.

The wiring should be done as per Fig. 34. The low voltage wiring to the outside condensing unit and the cooling thermostat are not shown. See condensing unit diagrams for that information.

This style of relay is used to lock out the feeder system of the pellet furnace when the A/C unit is calling for cooling. This is a fail-safe against both units operating at the same time. See the **NOTE** in the lower left corner.

**CAUTION:** Regardless of the supply air duct size installed, the Distribution Blower Motor **MUST** be checked for running Amperage. Check the motor name plate for the full load AMPS. If the amperage is running higher than that listed, a supply air restricting damper may be required to increase the supply plenum positive static pressure.

### NOTE:

It is highly recommended that the furnace control be turned to the "OFF" position whenever air conditioning is being used, whether or not it is interconnected.

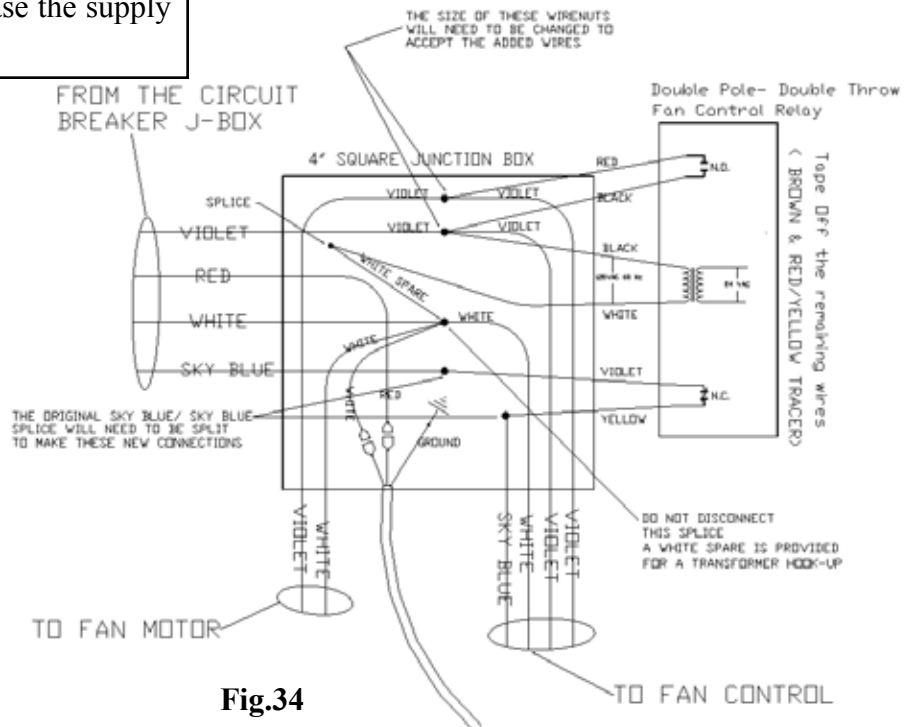

Fig.34

# Installation

## FAN/HIGH LIMIT CONTROL

### Installation & Set-up

1. The Fan Control must be placed in the discharge plenum approximately 11 inches above the discharge opening of the furnace, as close to center as possible.

**Note:** The best place is on the same side as the ash door because of ease of access. See Fig. 35.

**Note:** Care must be taken when installing the Fan Control when an air conditioning A Coil is used. The Fan Control **must** always be installed below the A Coil in low plenum installations.

2. Install the flex and wiring.

3. Make sure that the flue venting will not interfere with the flex to the Fan Control.

4. Pry out one of the bottom knockouts of the Fan Control. Install the 90 degree flex connector as shown in Fig. 36. One of the locknuts stays on the outside of the box and one goes on the inside to tighten the connector into place. This allows for maximum room for the wires around the switches.

5. **REMOVE THE COPPER JUMPER BETWEEN THE LIMIT AND CONTROL SWITCHES. (It is not needed.)** Figure 36 shown with copper jumper already removed.

6. Connect the two VIOLET wires to the FAN CONTROL switch. (It doesn't matter which wire is on which screw). See Fig. 36.

7. Connect the WHITE and SKY BLUE wires to the LIMIT switch. (It doesn't matter which wire is on which screw). See Fig. 36.

8. Make sure that all of the wires are out of the way when closing the cover. (Excess twisting and pinching of the wires could cause a short circuit.)

9. HIGH LIMIT setup is simple, just rotate the high limit pointer clockwise until it is against the tamper-proof screw. (Never adjust this screw)

10. FAN CONTROL setup: Move both fan control pointers together until they touch, then rotate both pointers together until the gap between them is directly over the middle 0 of 100. See Fig 36.

**Note:** This is the best fan control position we have found during factory testing. These fan control settings can be adjusted if desired.

High limit fan control

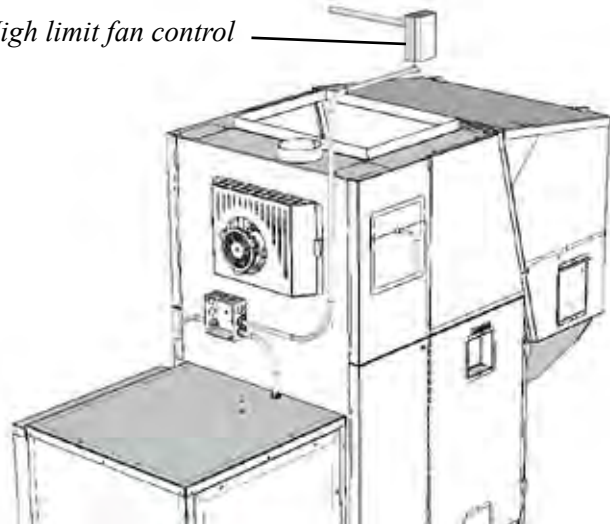

Fig. 35

Fan Control Setpoint

High Limit Setpoint

LIMIT

CONTROL



Locknuts outside and inside

Fig. 36

**NOTE: KEEP THE FAN/LIMIT CONTROL INSTRUCTIONS WITH THE OWNERS MANUAL FOR FUTURE REFERENCE.**

**NOTE: If fans are used in the fuel storage area, they should be installed so as not to create negative pressure in the room where the solid-fuel-burning appliance is located.**

# Installation

## Installing Electrical Power:

To install power to the furnace first remove the cover on the circuit breaker junction box shown.

Inside you will find the main terminal block. (See wiring diagram on page 36 for location of main terminal block and proper power connections). In the bottom of the box a knockout hole is provided for the incoming wire.

The **minimum** recommended circuit is 15 Amp 120 V.A.C. 60 Hz. This furnace should be the only appliance on the circuit.

**This furnace should never be powered by the use of an extension cord.**

The recommended high and low voltages are, 130 V.A.C. 60 Hz maximum high voltage, and 113 V.A.C. 60 Hz minimum low voltage.

The furnace will continue to operate at voltages as low as 105 V.A.C. , although it can not be guaranteed that automatic ignition will occur. Also, there is the possibility of a distribution blower motor overload.

**NOTE: If other sources of electrical power are to be used (such as a generator) for normal operation or emergency operation, this source should be checked before installation. Many generators and inverters may not supply 120V.A.C. 60Hz. power stable enough to operate the control board properly. (Control board damage could occur).**

## Checking & Recording the Low Draft:

After the venting is completed, the firebox low draft will need to be checked and possibly adjusted. After removing the 3/8" bolt from the draft hole shown in Fig. 38, insert the draft meter tube. The inner ash door and the hopper lid must be latched during this test. ( It is recommended that the draft meter have a scale of 0 to 1" WC.)

Turn the Feed Adjuster to "Test". this will start the combustion blower and allow you to check and record the High Draft \_\_\_\_\_ - IWC date \_\_\_\_\_ (There is no adjustment for the High Draft)

After the first 60 seconds, the "Test" mode lowers the combustion blower voltage to the Low Burn voltage. During this lowered voltage cycle the **Low Burn Draft must be checked** and adjusted if necessary. The recommended low draft setting should be between -.25 & -.35 IWC. Depending on the amount of vertical rise, it may not be possible to get a low draft reading in this range. In this case, a maximum low draft of -.55 is acceptable.

The adjustment screw is through the small hole to the right of the Igniter Light. See Fig. 39. Adjusted the Low Draft to \_\_\_\_\_ -IWC.

**Don't forget to turn off of "Test" mode.**

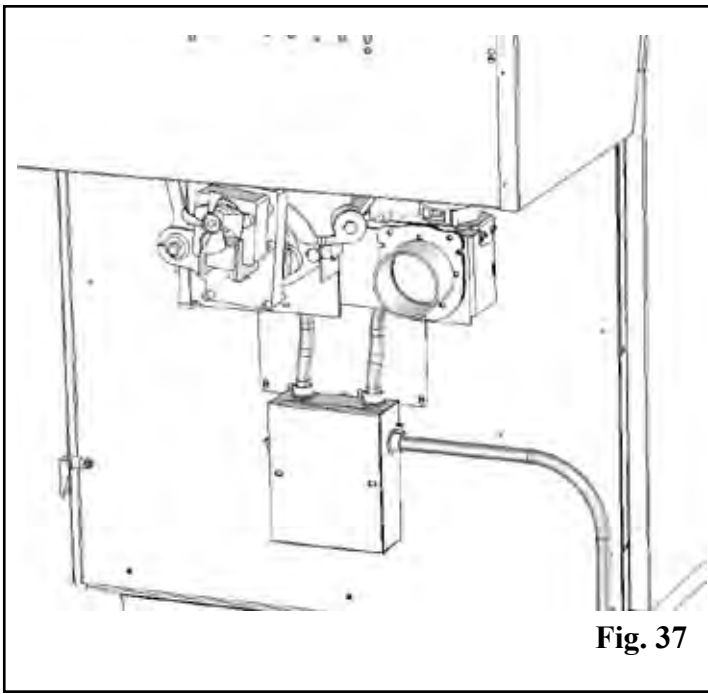

Fig. 37

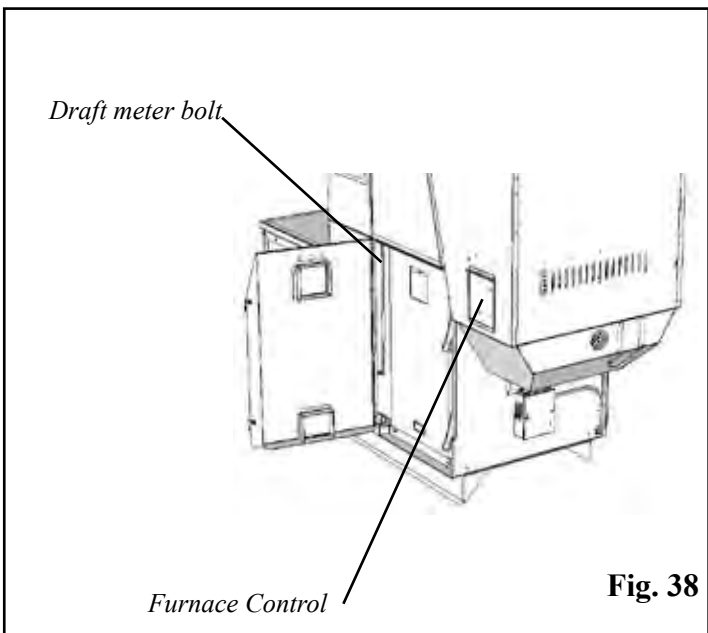

Fig. 38

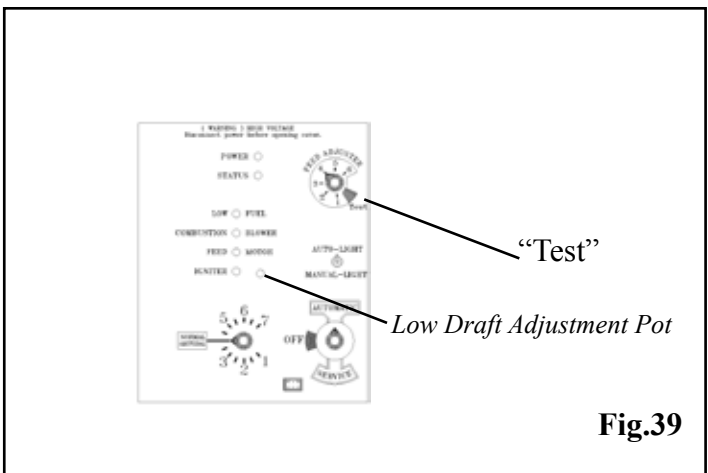
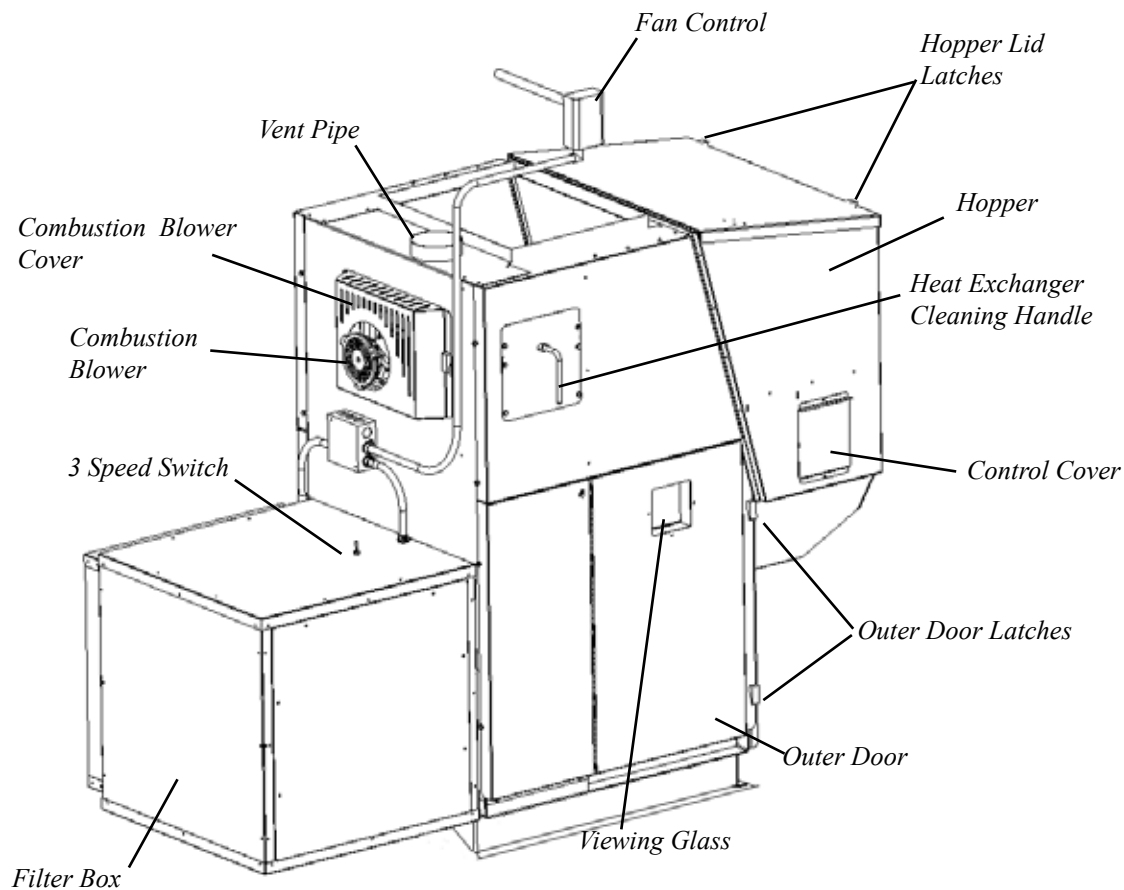
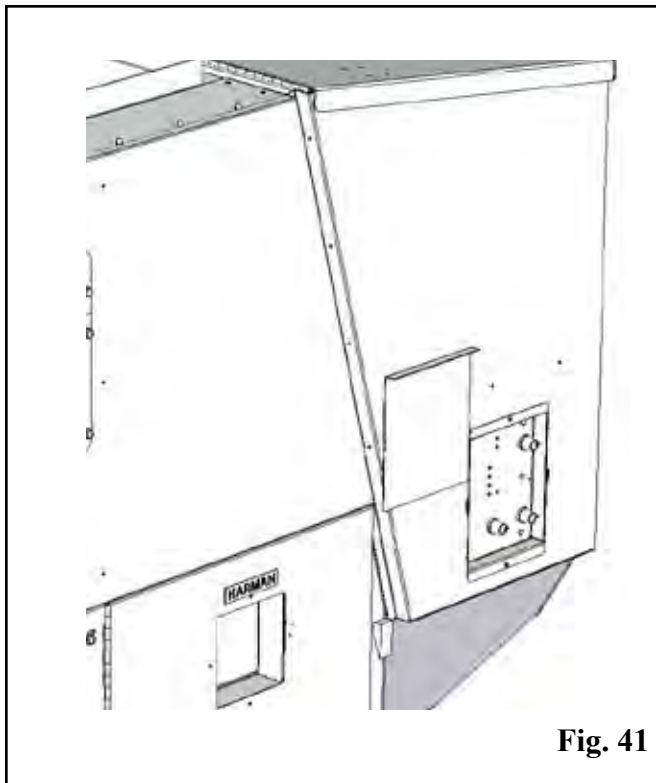

Fig.39

# Operation



**Fig. 40**



**Fig. 41**

## The Control

The control can be covered as shown above, or uncovered as shown at left. There is a pair of slots provided for each position. Simply move the cover to the desired position by placing the tabs on the cover in the proper slots.

**CAUTION: HOT WHILE IN OPERATION. DO NOT TOUCH. KEEP CHILDREN, CLOTHING, FURNITURE, AND OTHER COMBUSTIBLE MATERIAL OUT OF THE INSTALLATION CLEARANCE AREA.**

**WARNING: DO NOT OPERATE WITH FIRE CHAMBER OR RASH REMOVAL DOORS OPEN.**

**WARNING: DO NOT STORE FUEL OR OTHER COMBUSTIBLE MATERIAL WITHIN INSTALLATION CLEARANCE AREA.**

# Operation

## Power Light

Indicates power to the control, and is also used during "Test" to check the Low Fuel Sensor operation.

## Status Light

Will be lit in either automatic or service mode when pointer is not within off position band except after normal shut down. It also blinks to indicate errors as listed below.

## Low Fuel Light

Indicates that fuel in the hopper is low and needs to be refilled.

## Combustion Blower Light

Indicates Power to combustion blower

**Feed Motor Light** Indicates Power to the feed motor.

## Igniter Light

Indicates power to the igniter

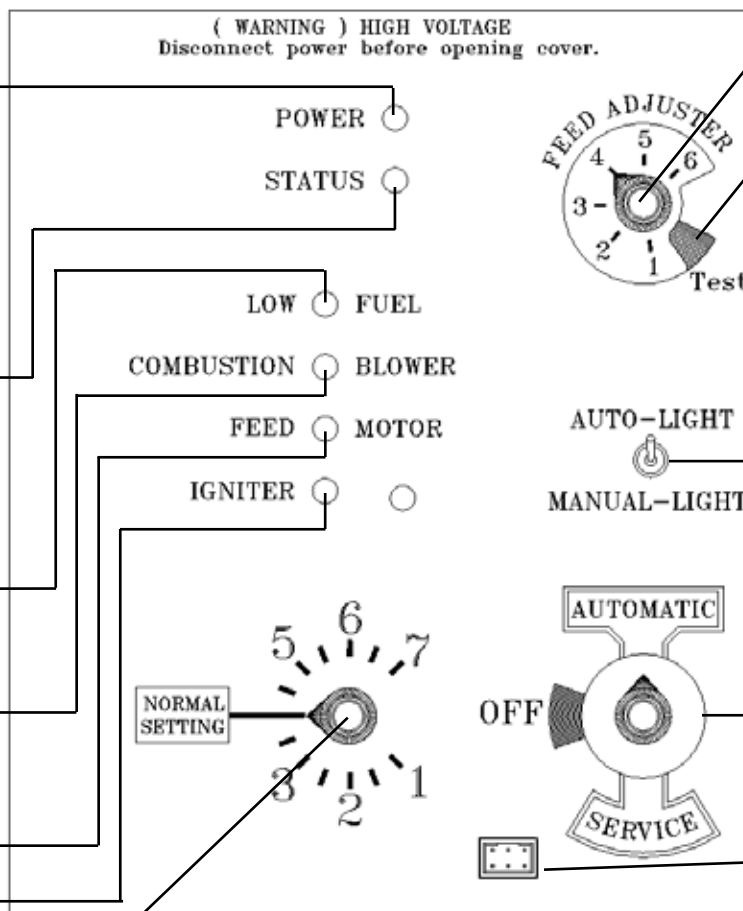

Fig. 42

## Feed adjuster

Sets the maximum feed rate

## Test

Runs all motors \*\* at full speed for one minute to check operation. After one minute the combustion blower will go to it's minimum speed and remain there. This is to allow for low draft voltage adjustment.

## Lighting Mode Selector

Switched between Auto and Manual lighting

## Mode Selector

See explanation below.

## Diagnostic Display Port

Requires special DDM monitor supplied exclusively to service technicians.

## Temp dial

The "Temp Dial" should be in the "Normal Setting" position except when service work is being done. It also allows you to adjust the fire temperature when the "Mode Selector" is in "Service Mode" using the scale marked from 1 to 7.

## Status light error messages:

**3 Blinks:** Indicates that the ESP (Exhaust Sensing Probe) has gone out of range too many times. If the unit seems to be operating normally, Perform a manual reset\*. If the code persists, you'll need to call a service technician.

**4 Blinks:** Can occur only in the Automatic Mode and indicates the Wall Control has failed or is not installed. If a Wall control is then installed the status light will automatically reset.

**5 Blinks:** (In Auto Light Mode Only)

Indicates that the igniter has failed to light the fire after 4 consecutive 8 minute attempts. To reset - Turn the Mode Selector to OFF and then back to Automatic.

**6 Blinks :** Indicates that the control has calculated poor or incomplete combustion occurring for more than 50 minutes. A six blink status may be set if the stove is allowed to run out of pellets. To reset, turn mode selector to "OFF" then back on to the desired mode. If the unit was not out of pellets, see Troubleshooting section, Page 34, for more details.

\* **Manual reset**, disconnect power at the circuit breaker for a few seconds and reconnect. If error still occurs call your Dealer.

## Mode Selector

Allows you to choose between Automatic Mode, Service Mode or OFF.

## Automatic Mode

Automatic mode switches operational control of the furnace to the wall mounted control. This is the mode to use whenever the furnace is burning in a normal heating application.

## Service Mode

Service mode switches control of the furnace to the temp dial. The temp dial can be set from 1 to 7 to allow a steady furnace temperature at the desired level. The main purpose of this mode is to operate the furnace without having to go back to the wall mounted control.

## OFF Mode

Turning the mode selector to OFF will shut down the furnace.

\*\* The Distribution Blower is not controlled by the "Test" operation. The Distribution Blower has it's own Manual Test Switch on the Fan / High Limit Control cover.

# Operation

## Wall Control

The wall control acts like a thermostat, a thermister in the wall control is sending temperature information back to the micro processor on the furnace. This information is used to determine the need to increase or decrease the size of the fire according to the temperature demand.

## Setting The Room Temperature

To set the room temperature, simply turn the temperature dial to the desired setting. The control and the furnace will then perform to achieve the set temperature.

Note: The minimum temperature you can set with a full counter-clockwise knob position is 58 degrees. The maximum temperature you can set with a full clockwise knob position is 90 degrees.

Wall Control calibration: The “Normal Setting” on the Temp Dial of the Furnace Control (See Fig.44) calibrates the Wall Control temperature span. If the Temp Dial is not pointing to the “Normal Setting”, the temperature span could vary by 3 degrees up or down depending on the Temp Dial knob setting.

## Low Fuel Sensor

There is a low fuel sensor in the hopper that tells the control that the fuel level in the hopper has dropped below the sensor. When this happens, the Low Fuel light on the Wall Control will start to blink. You then know that it is time to fill the hopper with pellets.

Note: Testing the low fuel sensor can be done by turning the FEED ADJUSTER knob to “Test”. The POWER light will go off when the sensor is uncovered and will light when the sensor is covered again.

Note: The LOW FUEL light on the Furnace Control will light at the same time. Only the LOW FUEL light on the Furnace Control will remain lit for three minutes after the sensor is covered with pellets. See Note below.

Note: The Low Fuel light indicates that there is power going to the auxiliary leads in the circuit breaker junction box. (120 VAC 60 Hz Max. 1 Amp.)The auxiliary power leads could be used if a bulk hopper and auger system were installed. (see wiring diagram on page 36)

## Type of Fuel

Pelletized wood only. Note: The lower the ash content of the pellets means less heat exchanger surface cleaning that will be needed. The cleaner these surfaces are kept, the more efficient the furnace will be.

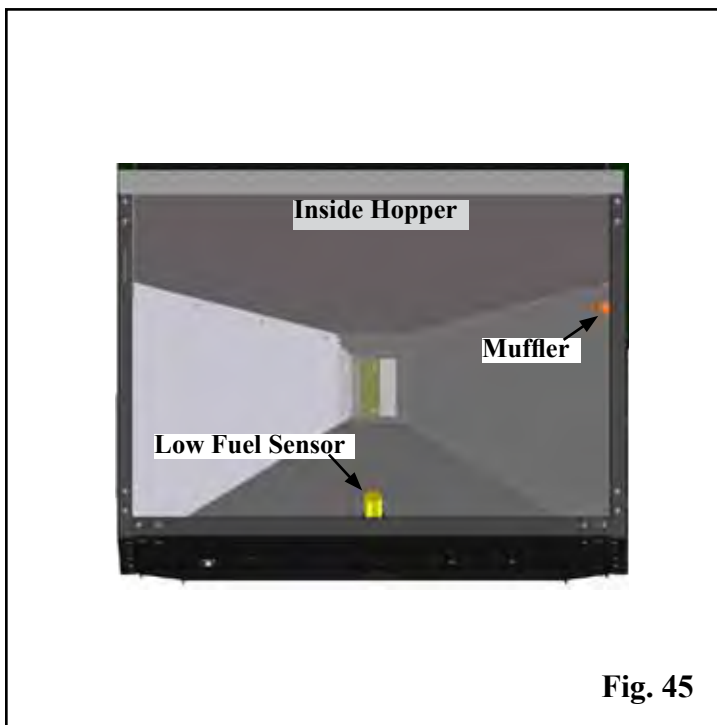
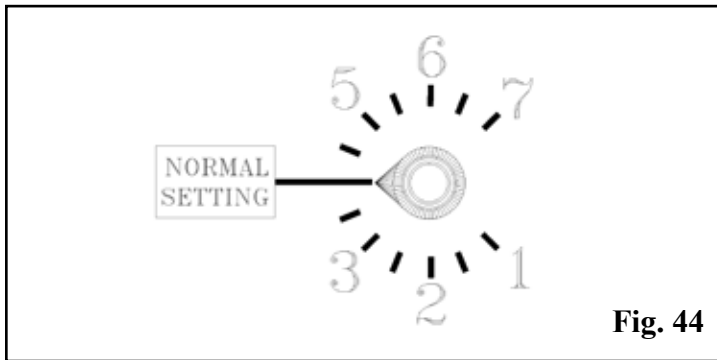
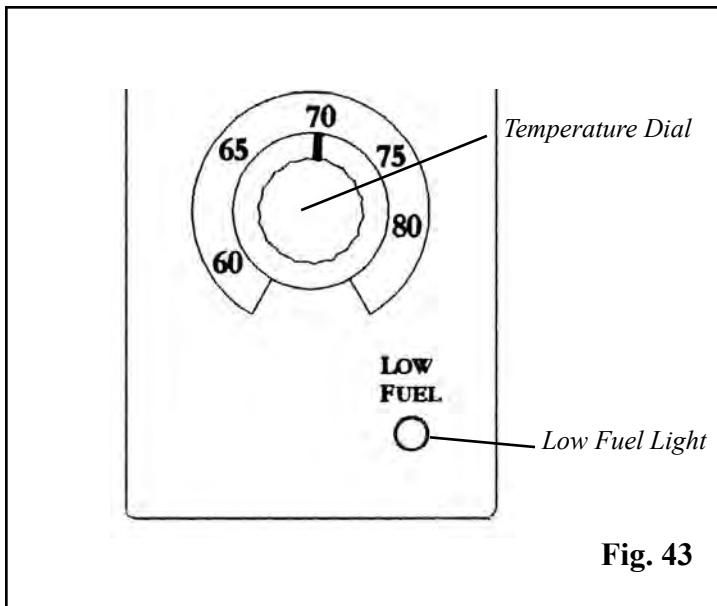

## Starting A Fire Automatically

**IMPORTANT:** Be sure there is no fuel or other combustibles in the ash pan prior to lighting.

### 1. Turn Mode Selector to “OFF”.

This resets the control in addition to turning it off.

### 2. Fill hopper with pellets.

When filling the hopper check for excessive fines in the bottom of the hopper. Fines are small pieces of broken pellets (sawdust). Fines do not flow easily and often build up on the hopper funnel bottom angles. These fines can be pushed into the feeder opening and then fill the hopper with pellets. As the system works, they will be burned.

### 3. Clean burnpot with scraper, if necessary.

This is usually a weekly maintenance procedure. Cleaning the burn pot with the scraper with a small amount of new fuel in the bottom is not a problem. First, scrape the ashes on the front of the burn pot into the ash pan. Then scrape the hole grid surface downward into the burn pot. When the stove is ignited these scrapings will be pushed out by the feeder.

**Note:** If the Distribution Blower is running when the outer door is open, some air will escape around the door opening. This is not a problem. However, any dust that is caused in the cleaning process can potentially be transferred through the duct, or otherwise dispersed.

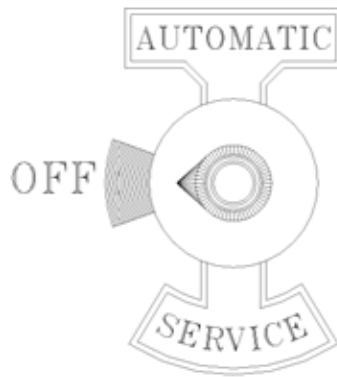

Fig. 46

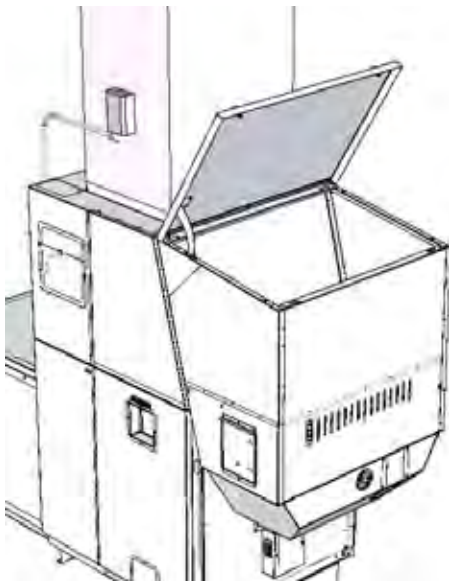

Fig. 47

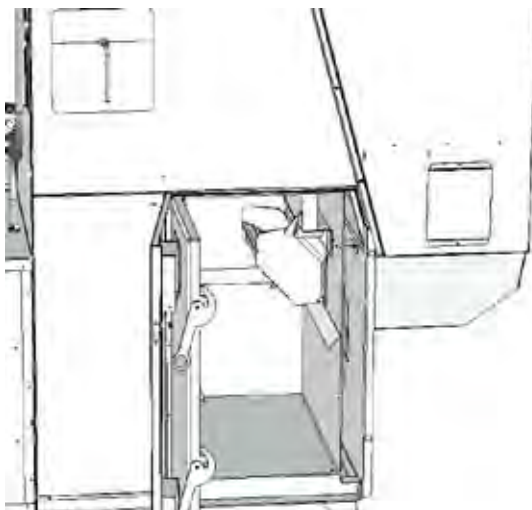

Fig. 48



# Operation

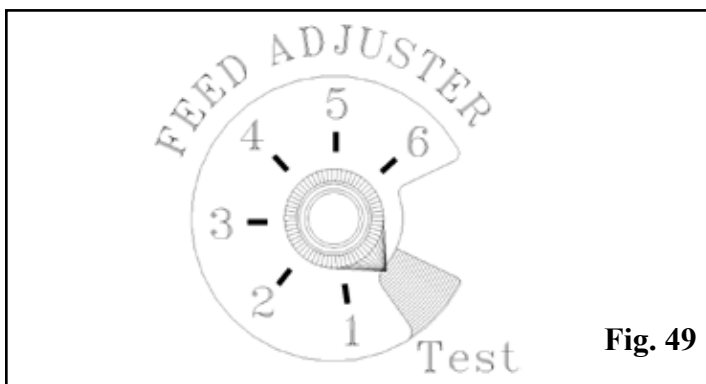

Fig. 49

4. If starting after an empty hopper, turn **Feed Adjuster** to “TEST” (for one 60 second cycle). This will charge pellets into the auger tube and also allow you to check the motors for operation. **NOTE: The auger motor will not operate with the furnace door open.**

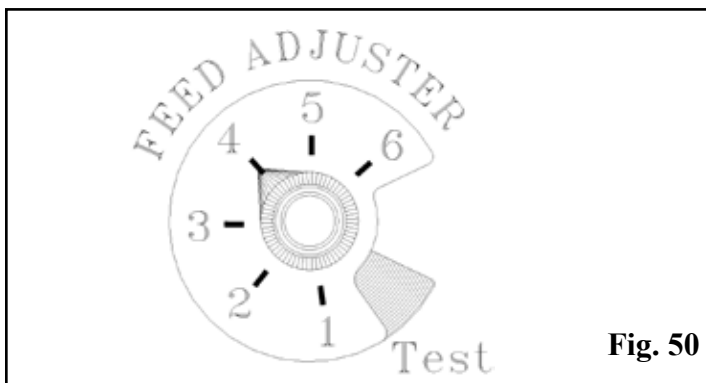

Fig. 50

5. **Turn Feed Adjuster to #4.**

If this is your first fire, or you are trying different pellets, set the feed adjuster to #4, Fig. 50. This is a conservative number and will probably need to be increased if maximum BTU output is desired. After you know a feed rate setting that works well for your application, use that setting. Remember, if your feed rate is too high you may waste fuel due to overshooting the Wall Control setting.



Fig. 51

6. **Flip the Igniter Switch up** into the “AUTO-LIGHT” position.

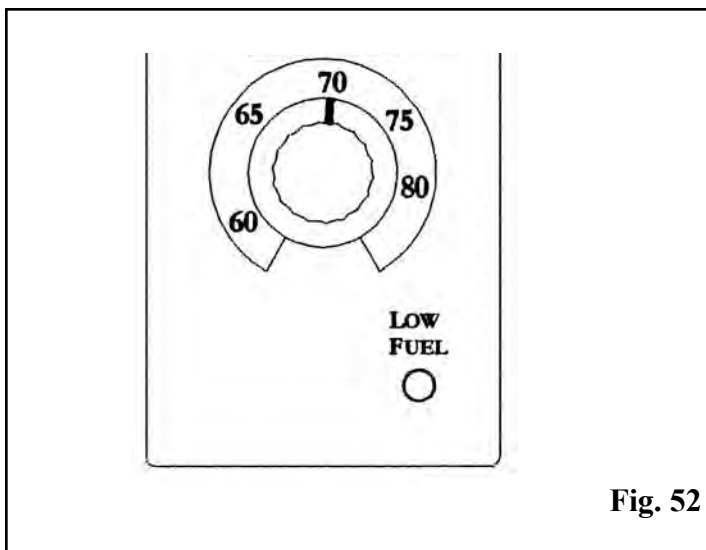

Fig. 52

7. **Turn the Temperature Dial** on the wall control to desired room temperature. Note: The set temperature on the dial must be higher than the room temperature for the fire to light.

**WARNING: HOT WHILE IN OPERATION. KEEP CHILDREN, CLOTHING, AND FURNITURE AWAY. CONTACT MAY CAUSE SKIN BURNS.**

# Operation

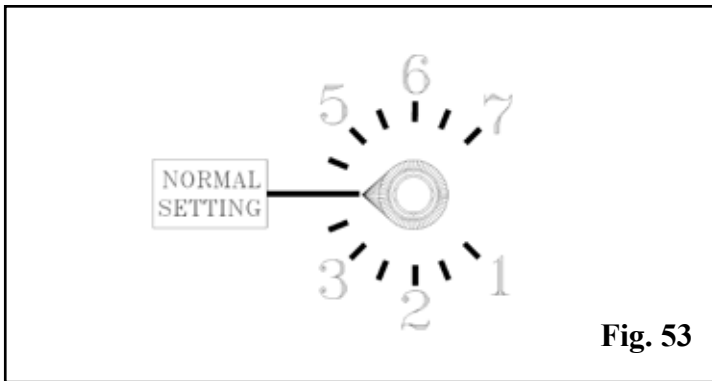

Fig. 53

8. Turn the **Temperature Dial** on the furnace control to “NORMAL SETTING”.

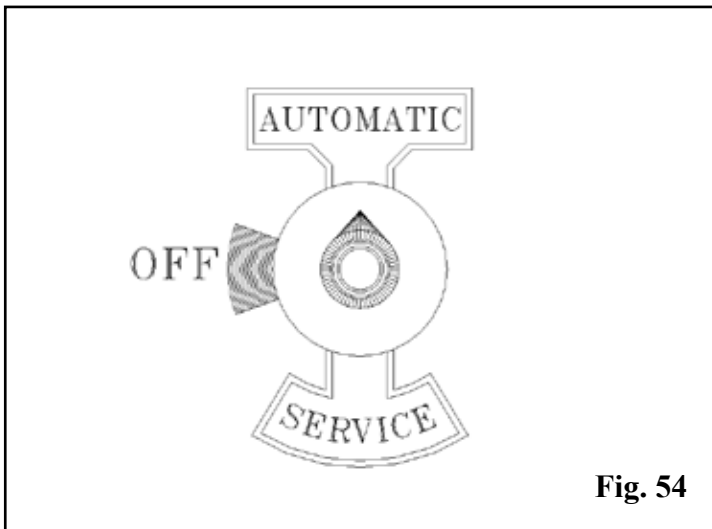
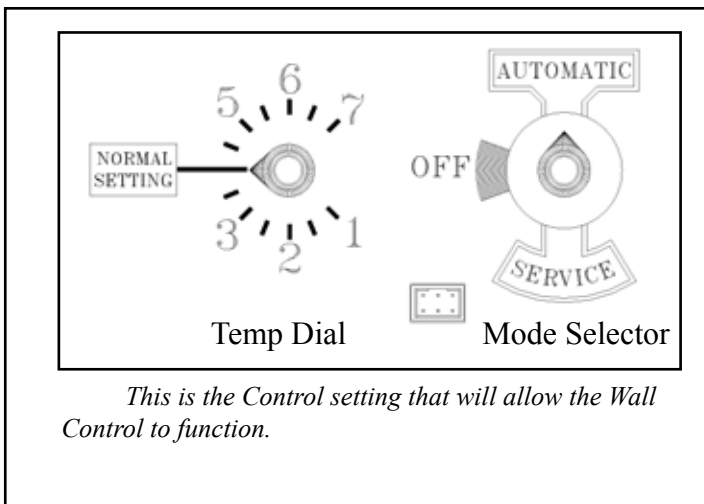

Fig. 54

9. Turn **Mode Selector** to “AUTOMATIC”

This will start the lighting process if the temperature at the wall control is less than the set temperature on the dial.

This unit is more than just an automatic ignition pellet furnace. The automatic system will allow the fire size to be adjusted to match the heating needs and even put the fire out if necessary. If heat is needed after the fire is out, the furnace will automatically re-ignite and adjust the fire size to match the heating need.



*This is the Control setting that will allow the Wall Control to function.*

10. **Fill the hopper** with pellets and **remove ashes** as required.

## Type of Fuel

Use pelletized wood only. **Note:** The lower the ash content of the pellets the less cleaning that will be needed of the heat exchanger surfaces. The cleaner these surfaces are kept, the more efficient the furnace will be.

**NOTE: Do not burn garbage, gasoline, naphtha, engine oil, or other inappropriate materials in the PF100.**

**Store pellets in the manufacturer’s wrapping until needed to prevent pellets from absorbing moisture. Do not store fuel within the appliance installation clearances, or within the space required for fueling, ash removal, and other routine maintenance operations.**

AUTO-LIGHT  
  
MANUAL-LIGHT

Fig. 55

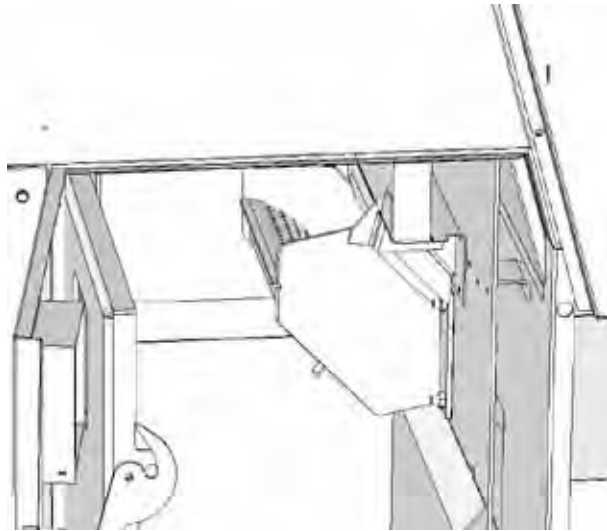

Fig. 56

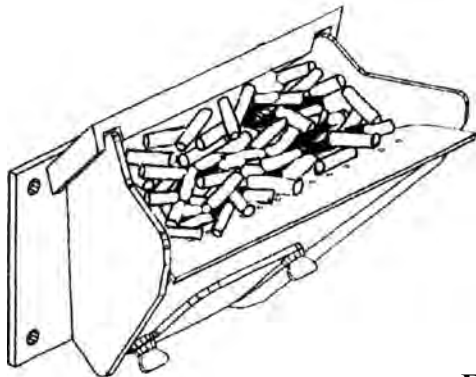

Fig. 57

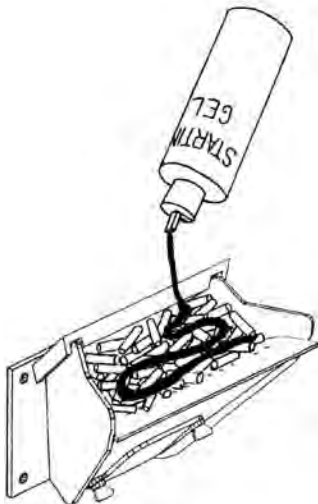

Fig. 58

## Lighting A Fire Manually

Lighting the fire manually will not be necessary unless the igniter system fails.

Follow steps 1 through 5 of the instructions for automatic lighting.

**6. Flip the Igniter Switch Down** into the “MANUAL-LIGHT” position. See Fig. 55.

**7. Open inner and outer ash doors** as shown in figs. 63, 64, 65, on page 30.

**8. Fill burnpot with pellets as shown.** See Fig. 57. **Only fill level with the front edge.** ( --- ---- DO NOT OVERFILL ----- )

**9. Have matches or other ignition source ready.**

**10. Turn Mode Selector to “SERVICE”**

This will start the combustion blower and allow the ESP to control the fire in relation to the Temp Dial setting 1 through 7. Once the fire is well established the Temp Dial can remain on any number setting desired, or changed to the “AUTOMATIC” setting. If you change to “AUTOMATIC” remember to set the Temp Dial to “Normal Setting” for proper Wall Control calibration.

**NOTE:** When the Switch is set to Manual-Lite in the “AUTOMATIC” mode, the Wall Control will function as in Auto-Lite except the fire will not be allowed to go out. It will only be allowed to go to a minimum burn rate between the times the Wall Control is calling for heat. This rate is about 1 pound of fuel per hour.

**“NEVER USE GASOLINE, GASOLINE-TYPE LANTERN FUEL, KEROSENE, CHARCOAL LIGHTER FLUID, OR SIMILAR LIQUIDS TO START OR “FRESHEN UP “ A FIRE IN THIS FURNACE. KEEP ALL SUCH LIQUIDS WELL AWAY FROM THE FURNACE WHILE IN USE”.**

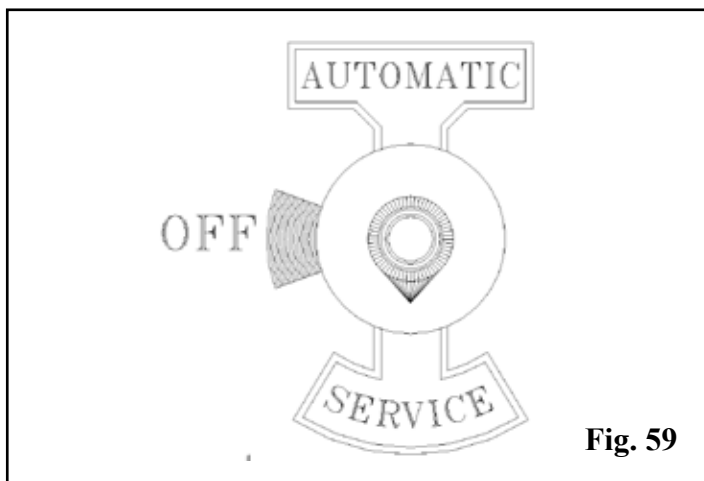

Fig. 59

## 11. Apply starting gel as shown in Fig. 58.

**NOTE:** Stirring the starting gel into the pellets usually allows the fire to become established quicker.

**CAUTION:** A vapor flash could occur if too much time is allowed to pass before lighting the starting gel.

**CAUTION:** Care must be taken not to get starting gel on your hands or clothing. Serious burns could occur during the lighting process.

**CAUTION:** Never try to apply more starting gel to an already burning fire, or a fire with smoldering pellets.

## 12. Light The Starting Gel With A Match.

## 13. Close The Doors

The fire will light and the control will adjust the fire to the proper level according to the temperature dial setting on the wall control.

## 14. Return air filter

Check the condition of the return air filter periodically and replace as needed.

## Shut Down Procedure:

The proper way to shut down the furnace is to turn the mode selector to "OFF". The control will decrease the feed rate to cool the fire. Once the ESP cools enough, the feeder will stop running. In order to ensure removal of smoke and gases from the remaining fuel in the burn pot, the combustion blower will operate until the ESP cools to a safe temperature. Depending on the size of the fire at the time the unit is turned to "OFF", this process could take as long as one hour.

Another method of shut down which is recommended at the end of the burn season, is to simply let the unit run out of fuel. This way, the hopper is empty for the off season.

**Never turn off the circuit breaker or otherwise disconnect power to the unit for shut down purposes!**

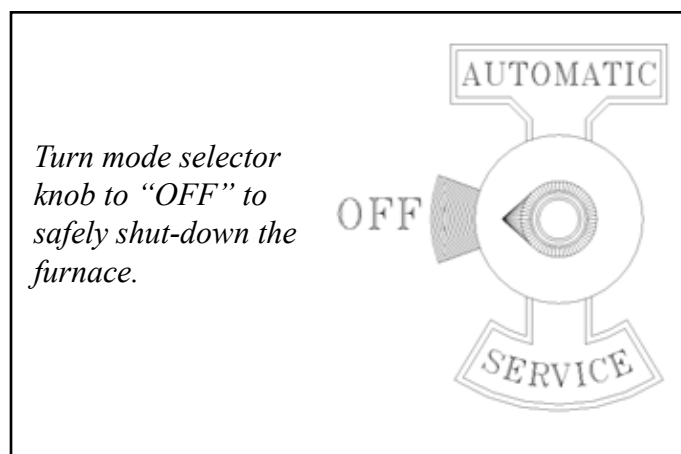

Solid-fuel burning appliances need to be cleaned frequently because soot, creosote, and ash may accumulate. If you suspect a chimney/vent pipe fire 1) Call the fire department. 2) Remove fuel from the burn pot using the burnpot scraping tool to scrape the pellets into the ash pan. 3) Remove the ash pan from the unit and take outside. Do not place ash pan on a combustible material. 4) Turn off circuit breaker at unit. 5) Do not use the unit until a qualified person has inspected your appliance and venting.

# Maintenance

## Burnpot cleaning:

The burnpot should be cleaned no less than once a week. For best operation the burnpot should be cleaned every time the hopper is filled with pellets. The fire does not have to be out to scrape the burnpot although it is recommended the furnace be on minimum burn at the time of cleaning.

**Note:** The furnace can easily be turned to minimum burn regardless of present operation. Simply turn the Mode Selector to SERVICE. Then turn the Temp Dial to the #1 setting. If this is done before starting to refill the hopper the furnace will not be as hot when scraping the burnpot. When the burnpot cleaning is completed don't forget to turn the control back to the Wall Control positions.

Use the flat end of the scraper provided to scrape down over the holed surface of the burnpot grate. See Fig. 62. It is not necessary to clean out the scrapings from this cleaning because they will be pushed out the next time the auger operates.

**Note:** Make a special effort to scrape the bottom inside corners of the burnpot where the auger tube enters the burnpot. Carbon deposits can build up over time in this area that may cause a restriction to the flow of pellets into the burnpot.

**Note:** An old long shank screwdriver with the end sharpened is an ideal aid in the removal of these deposits.

## Cleaning the burnpot air chamber:

This area only needs to be cleaned twice a heating season, unless excessive buildup is noticed during scheduled cleanings.

There is a cover on the front of the burnpot to gain access to the air chamber. The cover is held into place by two thumb screws. Loosen the thumb screws and remove the cover. See Fig. 60. The air chamber can be cleaned of any ash that has fallen through the holes during operation and cleaning.

**NOTE: ALWAYS REMEMBER TO CLOSE THE CLEANOUT COVER AFTER CLEANING.**

## Feeder Chamber (Fig. 61):

This chamber may get a buildup of fines from the feeder mechanism movement. This area should be checked and cleaned at least once a year.

### To remove the feeder cover:

- Remove the wing nut.
- Slide the cover off of the threaded stud.
- Inspect and clean the inner chamber if necessary. See Fig. 61.
- Reinstall the cover making certain it is centered on the feeder body and tighten as tightly as you can by hand.

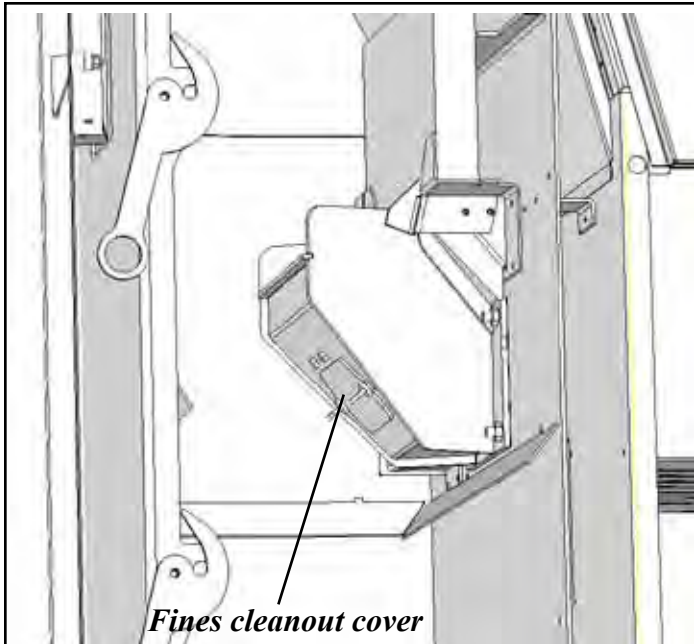

Fig. 60

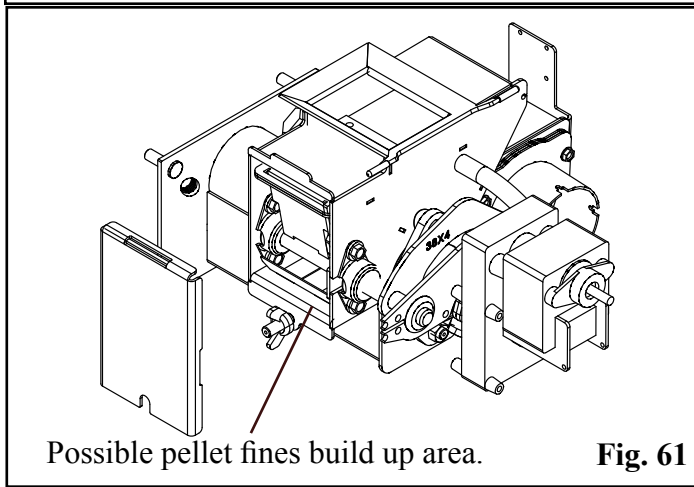

Fig. 61

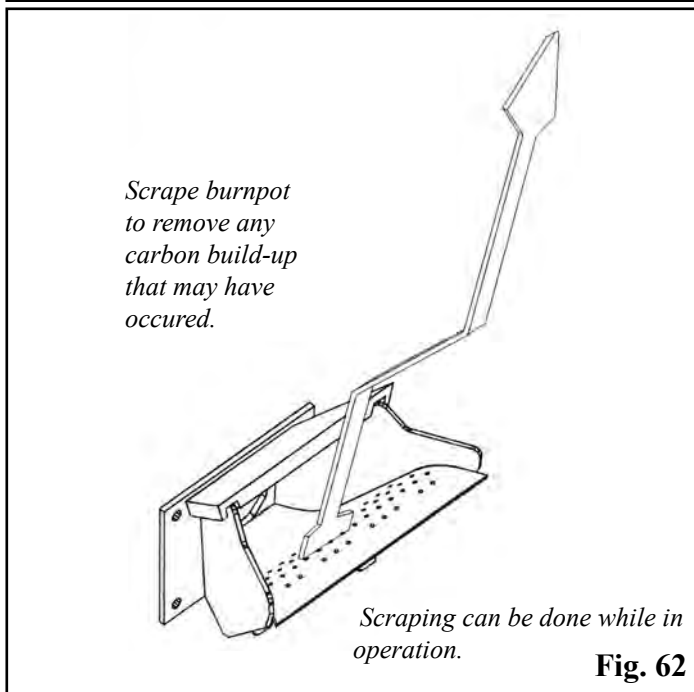
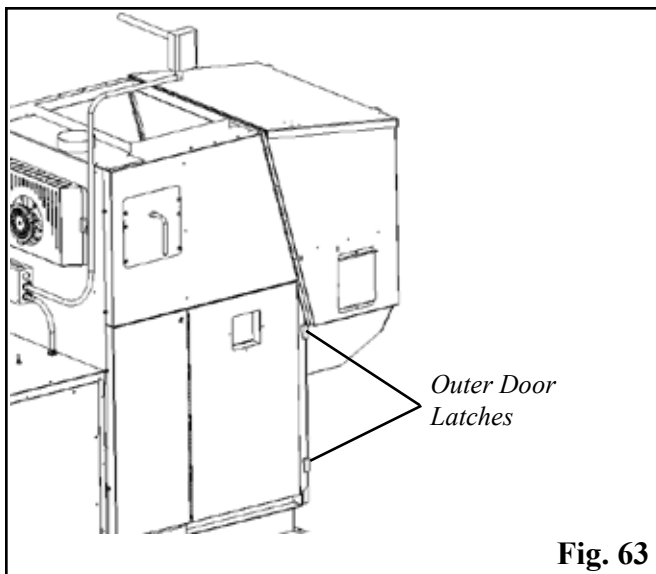

Fig. 62



## Ash Removal

It is recommended to remove the ashes when the furnace is not in operation. This lessens the chances of coming in contact with hot surfaces. Ashes can be removed while in operation but, extra care must be taken.

### Open Outer Ash Door

Lift the two latches shown in figure 63 and open the outer door as shown in figure 64. If the Distribution Blower is running when the outer door is open, some air will escape around the door opening. This is not a problem, however any dust that is caused in the ash removal process can potentially be blown around.

### Open Inner Ash Door

Lift latches shown in figure 64 and open the inner door as shown in figure 65.

**NOTE: Keep hopper lid and ash pan doors closed during operation and maintain all seals in good condition.**

### Remove Ash Pan

Always wear gloves to remove ash pan. Grab the ash pan by the handle and pull it out of the furnace. Lift the handle and use it for carrying the ash pan. **Close the inner door before disposing of the ashes.**

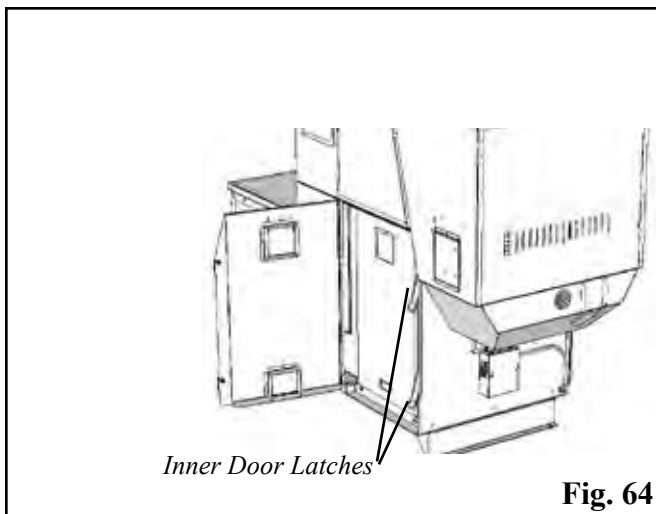

### Disposal of Ashes

Ashes should be placed in a metal container with a tight fitting lid. The closed container of ashes should be placed on a non-combustible floor or on the ground, well away from all combustible materials, pending final disposal. If ashes are disposed of by burial in soil or otherwise locally dispersed, they should be retained in the closed container until all cinders have thoroughly cooled.

### Soot and Flyash: Formation and Need for Removal

The products of combustion will contain small particles of flyash. The flyash will collect in the exhaust venting system and restrict the flow of the flue gases. Incomplete combustion, such as occurs during startup, shutdown, or incorrect operation of the furnace will lead to some soot formation which will collect in the exhaust venting system. The exhaust venting system should be inspected at least twice monthly to determine if cleaning is necessary.

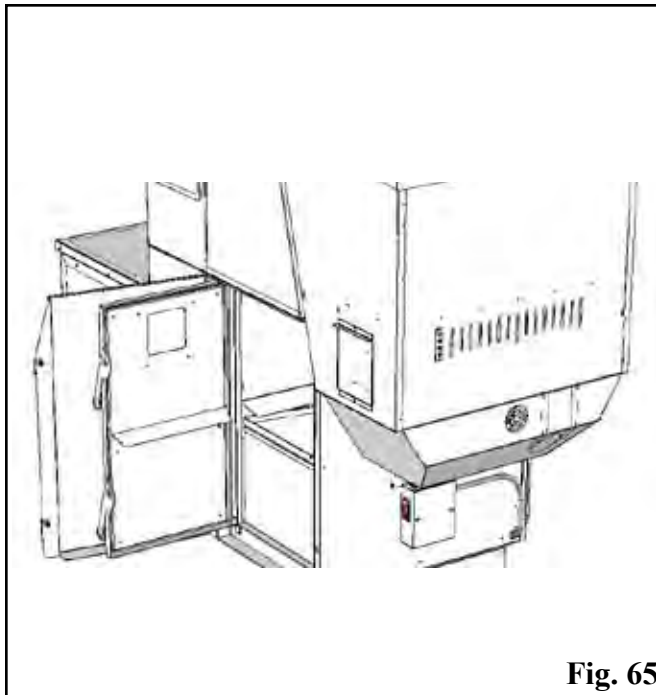

# Maintenance

## Cleaning the accordion heat exchanger/firebox:

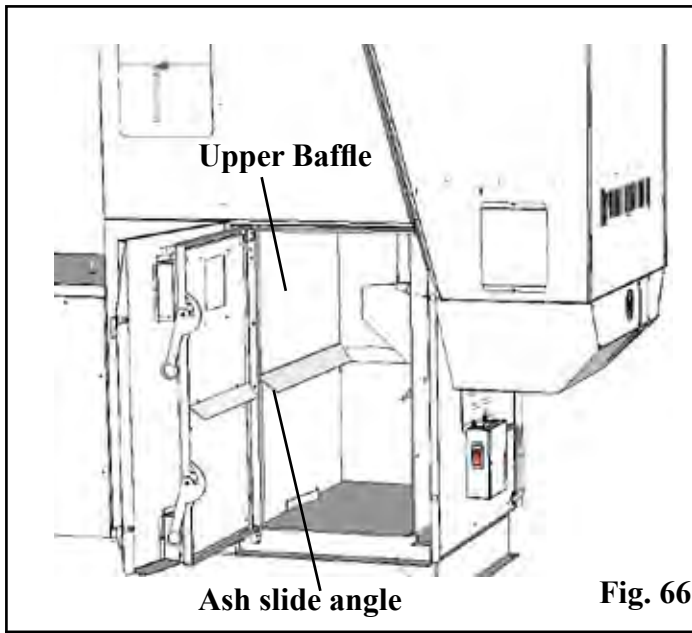

This cleaning should be done monthly, or after each ton of pellets used. The frequency of this cleaning will be directly related to the quality and the quantity of the pellets being used. Keep in mind that the cleaner the heat exchanger surface is kept, the higher the heat transfer efficiency will be.

Due to its ease of restarting it is recommended that the furnace be **OFF** and **COOL** before cleaning.

Before starting to clean the inside of the firebox area it is recommended that all of the baffling be removed. Start with the upper heat exchanger baffle. See Fig. 66. Push straight upward on the lower ash slide angle approx. 1/2". This will release the baffle from the positioning brackets and allow it to be tilted toward the burnpot and removed from the furnace.

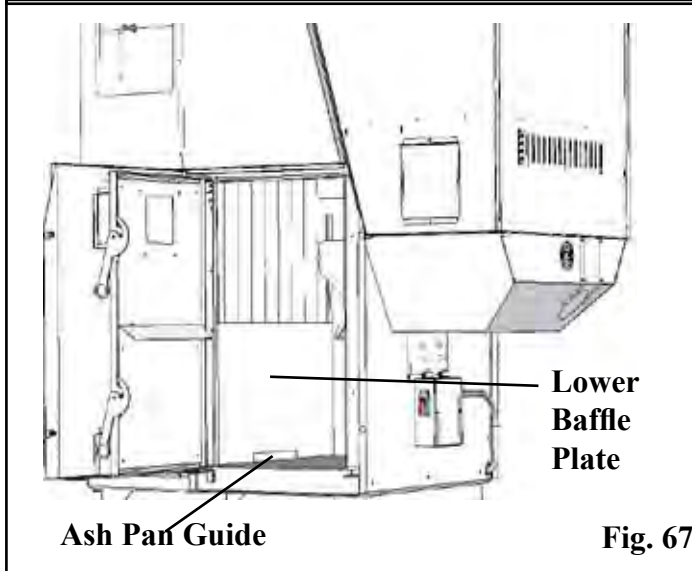

**Note:** Observe the positioning tabs and bracket system on the rear of the upper baffle as it is being removed, for easier replacement later.

Remove the lower baffle plate. This baffle is a flat plate that sits on the furnace floor. Tip the top edge toward the burnpot and lift up and out of the furnace. Note how the baffle bottom edge sits behind the ash pan guide and against the heat exchanger. See Fig. 67.

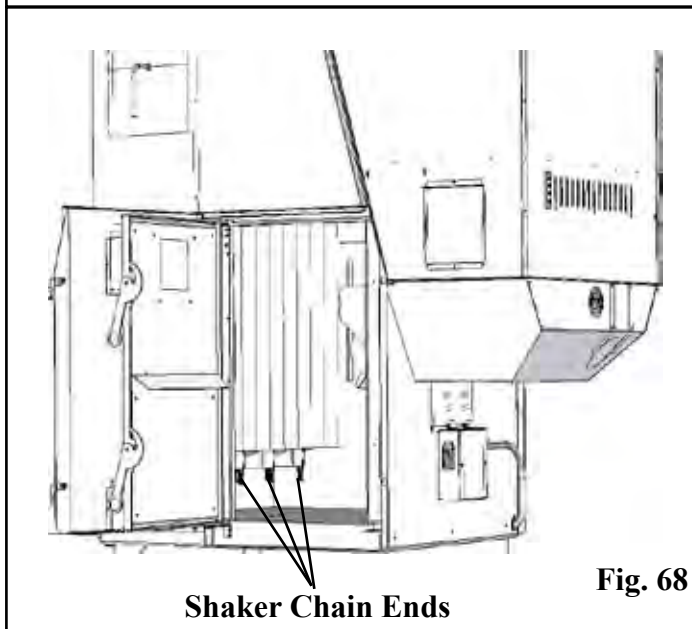

With all of the baffling removed, the entire firebox area and the accordion heat exchanger can be cleaned. Use the pointed end of the scraper supplied to clean the accordion heat exchanger. A small wisp brush, wire brush, or an old stiff bristled paint brush works best for cleaning the firebox walls. All of the fly ash removed during cleaning will fall to the bottom of the furnace where there is an unobstructed access for cleaning. Even the bottom ends of the chains can be seen and accessed easily from the door opening. See Fig. 68.

**CAUTION: Cleanout of the heat exchanger, flue pipe, chimney, and combustion blower fan housing, is especially important at the end of the heating season to minimize corrosion during the summer months, caused by accumulated ash.**

## Combustion Blower Cleaning

Remove the combustion blower heat shield. There are two latches that hold the shield in place. See Fig. 69. Flip the latches up and pull the shield away from the furnace. It can not be fully removed, it can only be moved down over the wire until it hangs on the junction box.

The furnace **MUST be OFF and COOL** before you should attempt to clean the combustion blower.

The wire to the combustion blower doesn't need to be disconnected during the cleaning process.

Loosen the three (3) thumb screws about 4 turns each. See Fig. 70. Hold the motor head with one hand and the blower plate handle with the other hand. Pull outward on the plate handle until the complete unit comes loose. Now rotate the plate counter-clockwise about 1/8 turn. This will allow the complete assembly to be removed from the blower chamber.

Clean the blower fan blades and the blower plate sealing overlap. See Fig. 71.

**Note:** Be careful not to bend the fan blades, this will throw the fan blade out of balance or it may rub the inner chamber, which may affect the performance of the furnace. Any horizontal and vertical flue pipe directly above the unit should be cleaned at this time.

**Note:** The horizontal flue pipe directly above the furnace is the first place fly ash will settle, due to the slowing of flue gas velocity through horizontal pipe. Cleaning of horizontal venting pipes is very important to the efficiency of this furnace.

The Draft Differential Pressure Switch monitors the draft pressure in the hopper. This fitting, known as the Muffler, may need to be cleaned occasionally. Use caution when performing any maintenance in the hopper so you don't damage the Muffler or the Low Fuel Sensor.

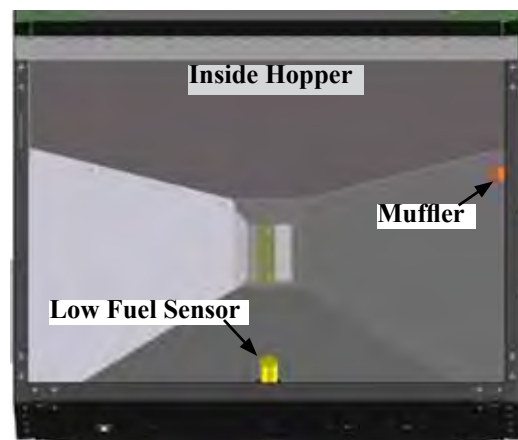
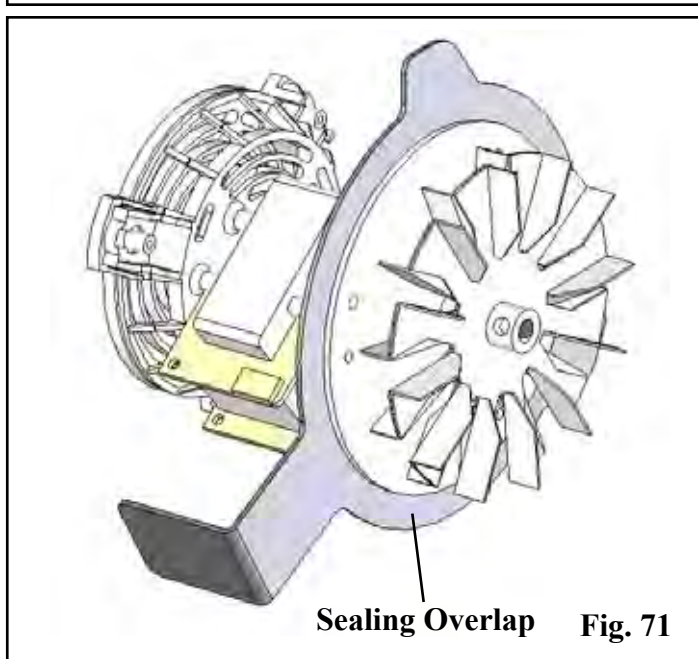
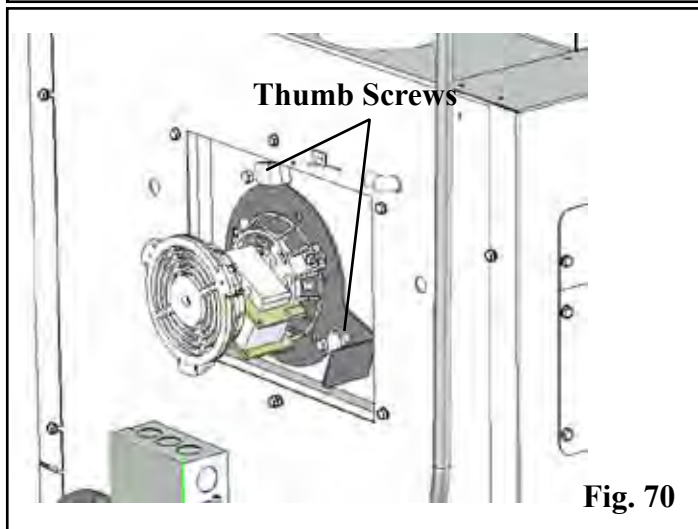
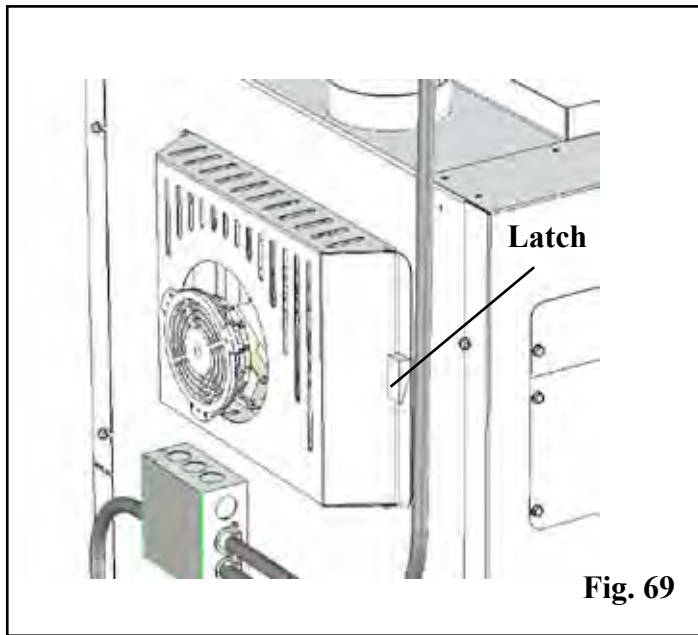



# Maintenance

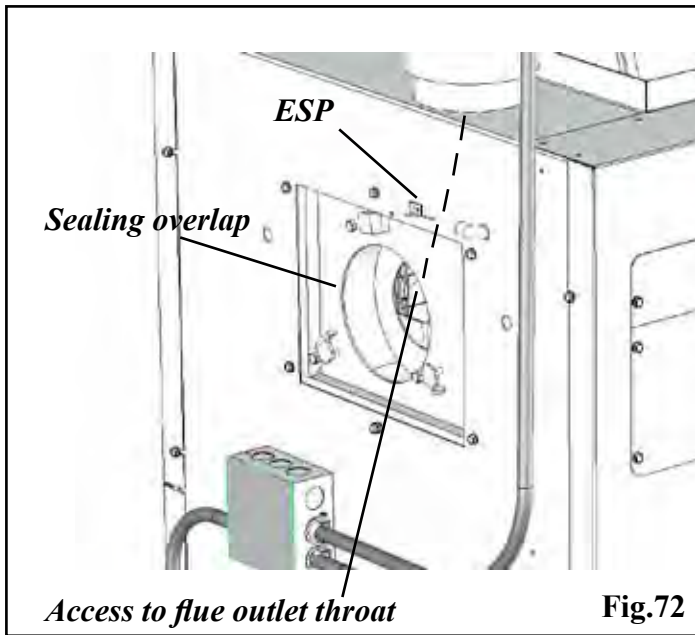

Clean the flue outlet throat ( this is the hole that goes up into the flue pipe). See Fig. 72.

**Note:** The ESP sensing tip extends into this same area. **CARE MUST BE TAKEN NOT TO DAMAGE THE ESP DURING CLEANING.** Bending of the ESP will make it difficult to remove if it should become necessary. See Fig. 72.

Clean the inner chamber of the blower. See Fig 72.

Clean the furnace blower plate, sealing overlap. See Fig 72. Inspect the tops of the heat exchanger tubes where the chain shaker mechanism is located. Make sure there are no fly ash buildups that may block the easy flow of flue gasses into the combustion blower inlet hole. (A flashlight may be necessary.)

Inspect the chain shaker mechanism for proper operation.

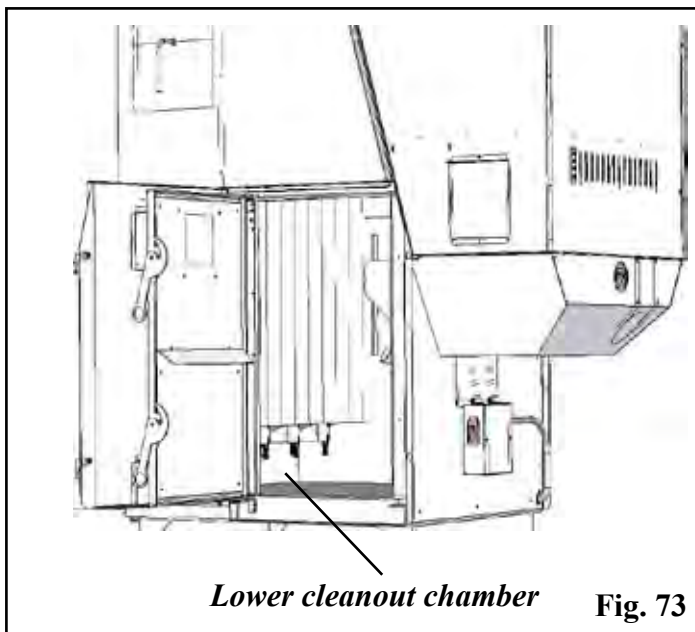

**Note:** Fly ash can build up to the top edges of the heat exchanger tubes without affecting operation. The chain shaker will cause any excess to fall down into the chamber under the tubes where it can be cleaned out through the fire box. See Fig. 73.

**CAUTION: Inspect flue pipes, flue pipe joints and flue pipe seals regularly to ensure that smoke and flue gases are not drawn into, and circulated by, the air-circulation system.**

## Cleaning the Tube heat exchangers:

The heat exchangers tubes have an external handle that operates the cleaning mechanism. See Fig. 74.

This cleaning should be done at least once a week, although it can be done as often as desired. The cleaner the heat exchangers are, the more efficient the furnace will be. This cleaning can be done at any time and in any mode of operation.

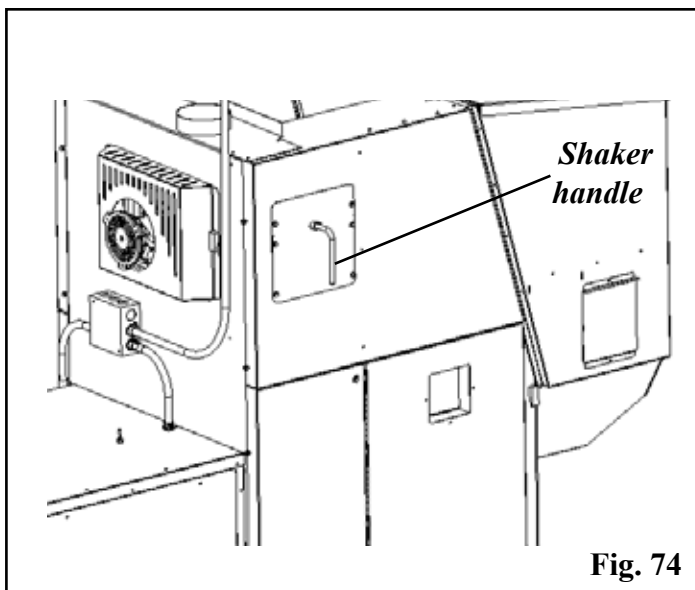

The handle has two directions of movement, Right to Left and In and Out. All inside surfaces of these rectangular tubes can be cleaned with this range of motion. First, with the handle pushed in, turn the handle right to left, the full sweep, several strokes. Second, with the handle pointing straight down, pull out and push inward several strokes. Third, with the handle all the way out, turn the handle right to left, the full sweep, several times. End with the handle pushed inward and pointing down.

# Troubleshooting

## FEEDER DOES NOT FEED

1. No pellets in hopper.
2. Firebox draft may be too low for low draft pressure switch in feeder circuit to operate. **Check for closed doors**, loose or missing gasket on doors or hopper lid, or a faulty pressure switch.
3. Feed motor will not run until ESP senses 165°F. Maybe you did not put enough pellets in the burn pot before lighting the fire manually.
4. Something is restricting flow in the hopper or causing the slide plate to stick.
5. Feed motor has failed.

## PARTIALLY BURNED PELLETS

1. Feed rate too high.
2. Draft too low. (Check burn pot clean-out slide and door gasket).
3. Burn pot or heat exchanger tubes may need to be cleaned.
4. Combination of all the above.
5. #6 status blink: A 6 blink control board status indication is caused by poor or incomplete combustion. The Automatic Ignition circuit board has the ability to track the combustion through feed settings and ESP temperatures. When the control board has calculated poor or incomplete combustion, it will shut down the unit as a safety feature. (Poor or incomplete combustion is a contributor of creosote which may cause a chimney fire)

### **A 6 blink status may be caused by several things:**

1. Blocked or partially blocked flue.
2. Blocked or partially blocked inlet air.
  - a. Backdraft damper on the inlet pipe may be stuck closed.
  - b. If outside air is installed, the inlet cover may be blocked.
3. The air chamber under the burnpot may be filled with fines and small bits of ash.
4. The holes in the burnpot may be getting filled with ash or carbon buildup.
5. Combustion blower fan blades may need cleaned.
6. There is no fuel in the hopper.

## SMOKE SMELL

Seal the vent pipe joints and connection to stove with silicone.

## FIRE HAS GONE OUT

1. No pellets in hopper.
2. Draft setting is too low.
3. Something is restricting fuel flow.
4. Feed motor or combustion blower has failed.
5. Power failure or blown fuse.

## SMOKE IS VISIBLE COMING OUT OF VENT

1. Air-fuel ratio is too rich.
  - A. Feed rate too high.
  - B. Draft too low caused by a gasket leak.

## LOW HEAT OUTPUT

1. Feed rate too low
2. Draft too low because of gasket leak.
3. Poor quality or damp pellets
4. Combination of 1 and 2.

## Helpful Hints

### **Cleaning Burn Pot**

Whenever your stove is not burning, take the opportunity to scrape the burn pot to remove carbon buildup. A vacuum cleaner is handy to remove the residue. **Be sure the stove is cold if you use a vacuum.**

Carbon buildup can be scraped loose with the fire burning using the special tool provided with your stove. Scrape the floor and sides of the burn pot. The carbon will be pushed out by the incoming fuel. Always wear gloves to do this.

### **Removing Ashes**

Turn the Temp Dial to number 1 approximately 30 minutes before removing ashes. This will result in a cooler stove and ash pan.

Maximum Feed Adjuster settings are not needed in most cases. Operating in the normal range (#4) is recommended when maximum heat output is not required. The ESP prevents the stove from being over-fired.

Keep the stove free of dust and dirt.

## Fuel

Pellet fuels are put into 3 categories in terms of ash content. Premium at 1% or less, Standard at 3% or less and all others at 3% or more.

This model is capable of burning all 3 categories of pellets due to a patented feeder and burn pot system.

It should be noted, however, that higher ash content will require more frequent ash removal, scraping of the burn pot, and may provide less BTU's per pound. Normally, standard and high ash pellets cost less than premium pellets and can be cost effective when burned in this unit.

The moisture content must not exceed 8%. Higher moisture will rob BTU's and may not burn properly.

# Specifications

## BTU Input Range 0 - 8500 to 112,000

0 if system is satisfied, then  
 min. burn = 1 pound per hour  
 max. burn = 13 pounds per hour

## Electrical 120 VAC 60 Hz.

combustion blower 1.4 AMP  
 auger motor .7 AMP  
 igniter element 3.7 AMP  
 control board .05 AMP

1000 CFM blower ( shade pole ) 6.5 AMP  
 1450 CFM blower ( PSC ) 4 AMP  
 1638 CFM blower ( PSC ) 6.9 AMP

Average electrical usage is .5 KWH

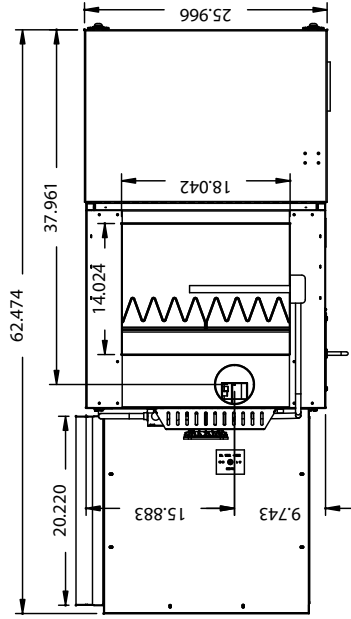

WITHOUT BLOWER BOX INSTALLED

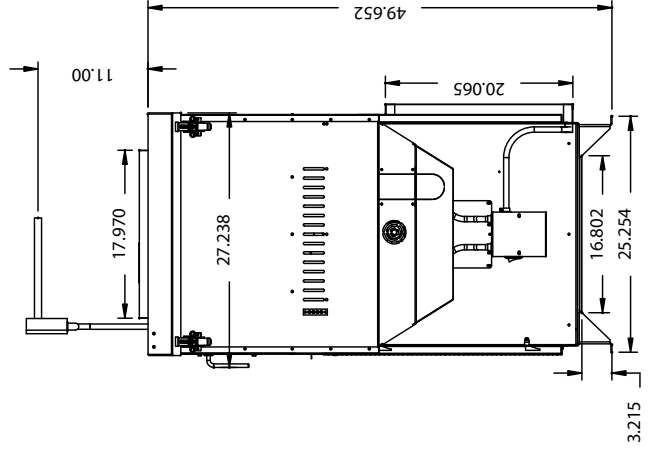
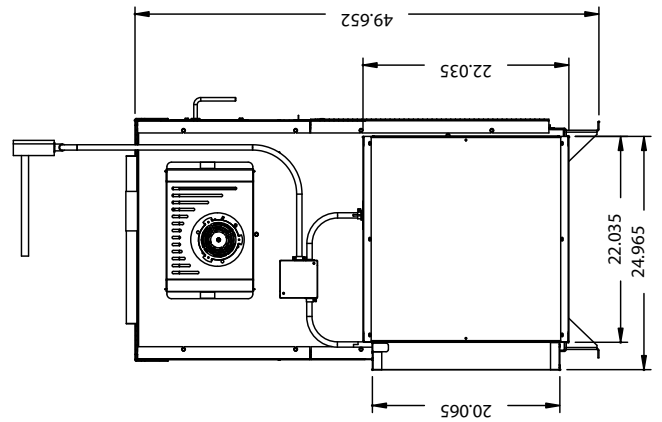
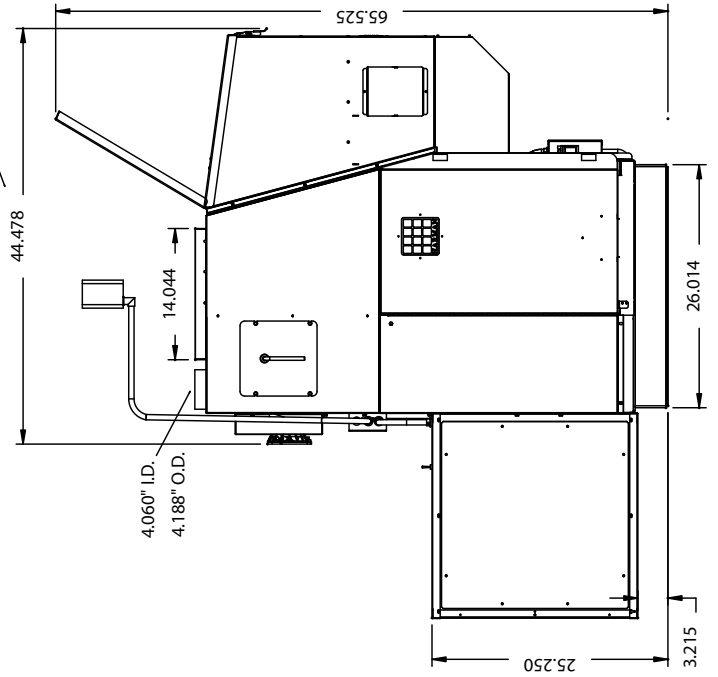

# Wiring Diagram

## PELLET FURNACE WIRING DIAGRAM

- 120 VOLTS A.C. 60 HZ.
- 10 AMPS MAX ( test mode )
- 1200 WATTS-
- 7.5 AMPS NORMAL OPERATION
- 900 WATTS-

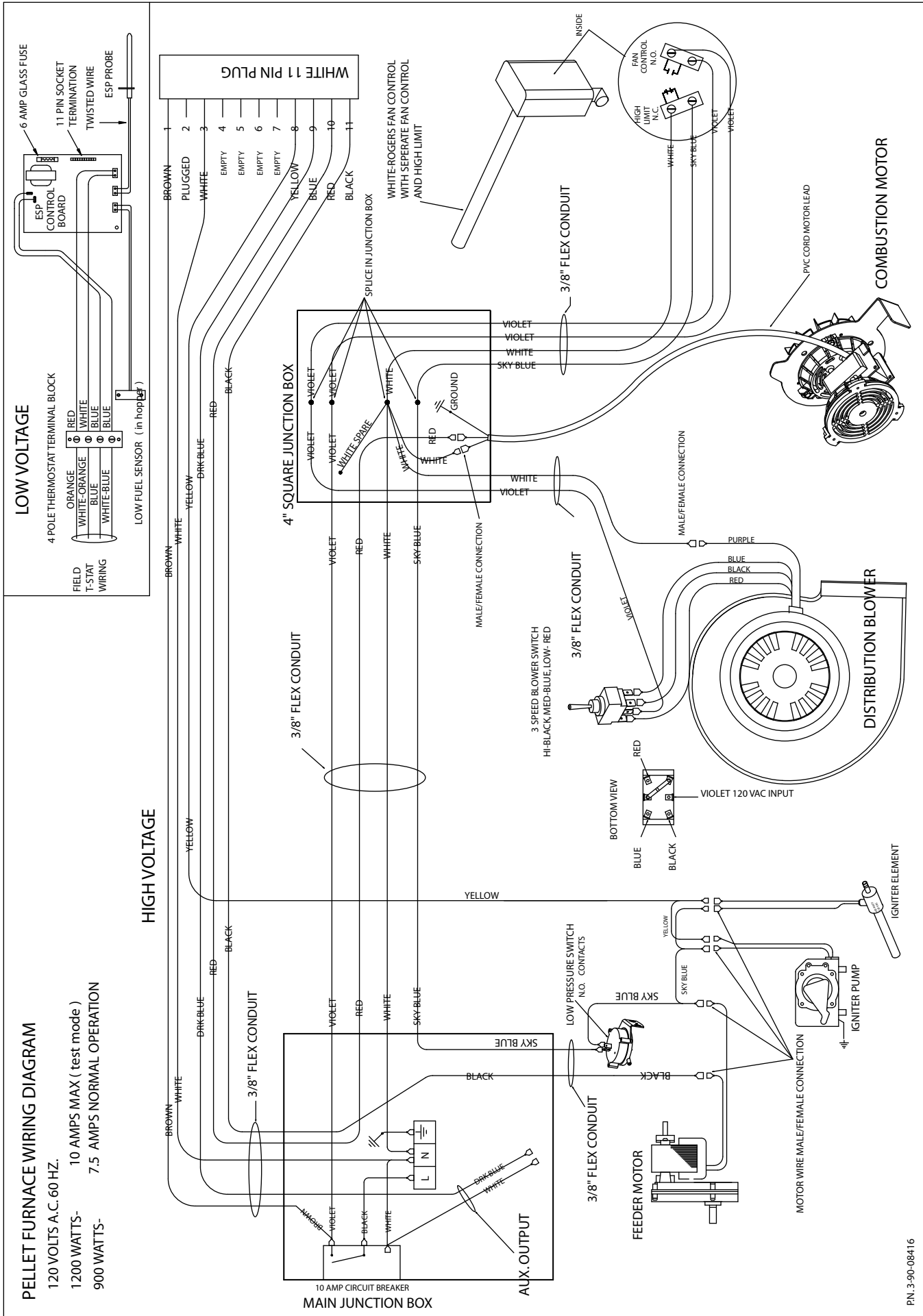

# Parts Identification

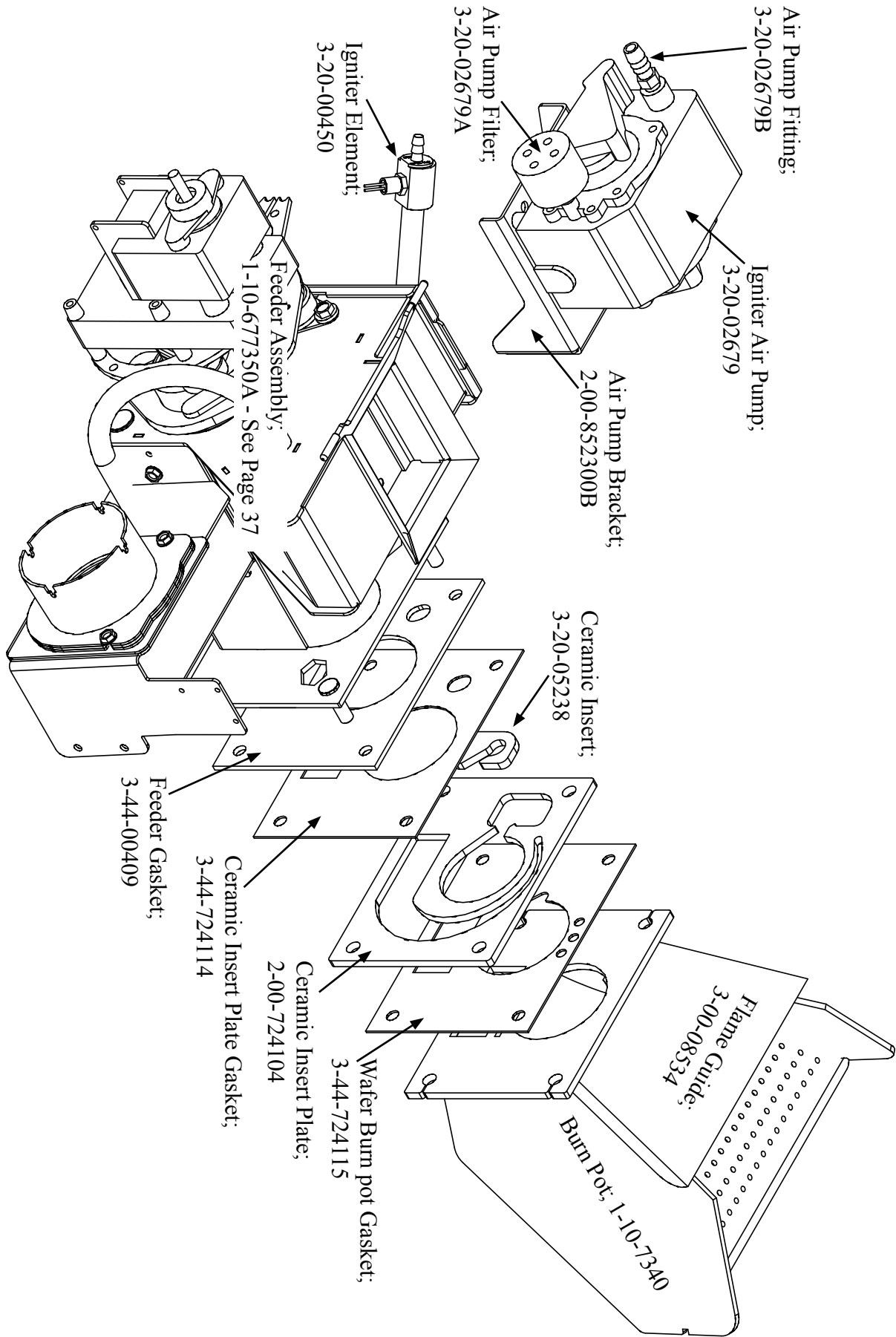

# Door Parts

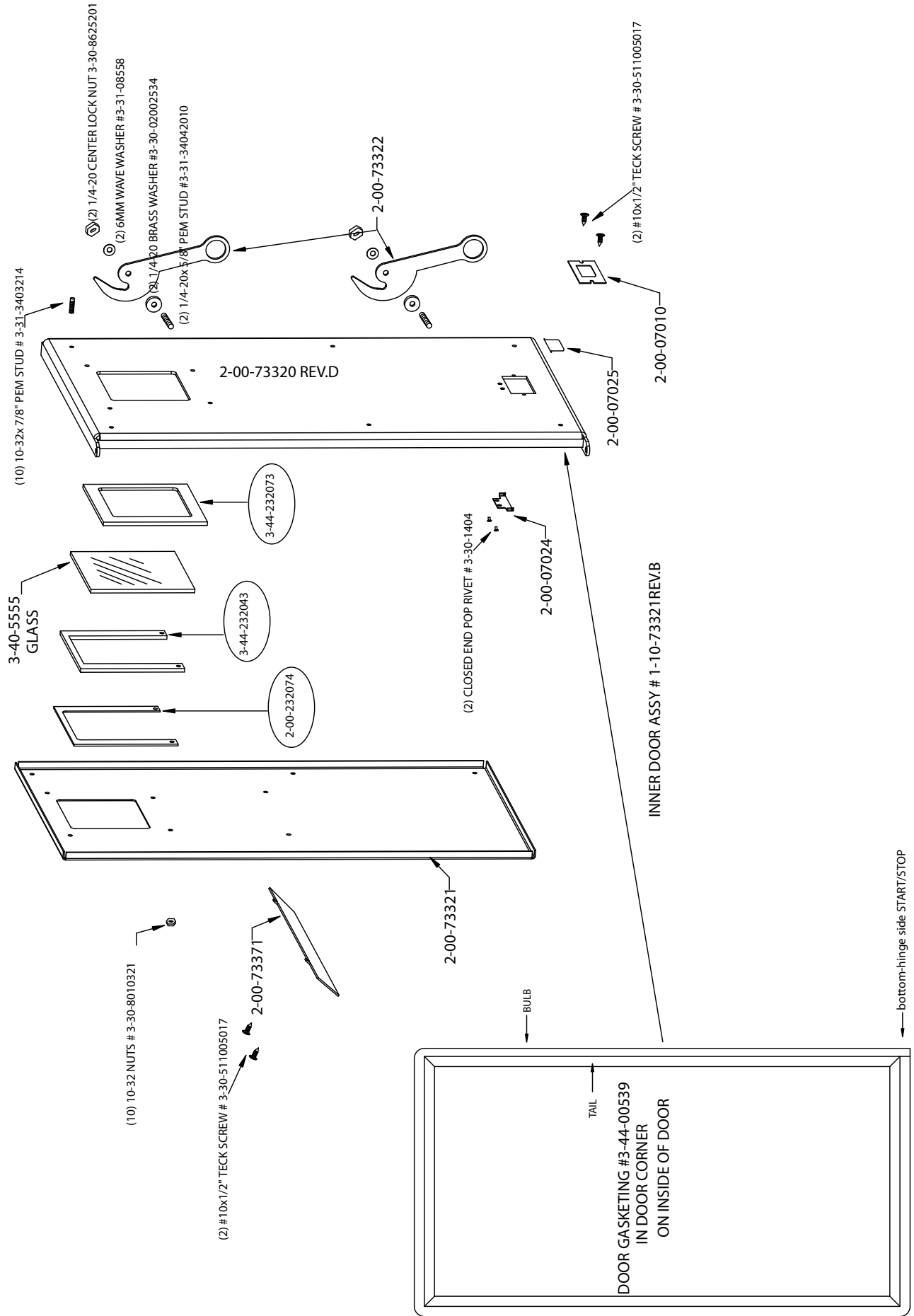

**1-70-08100**

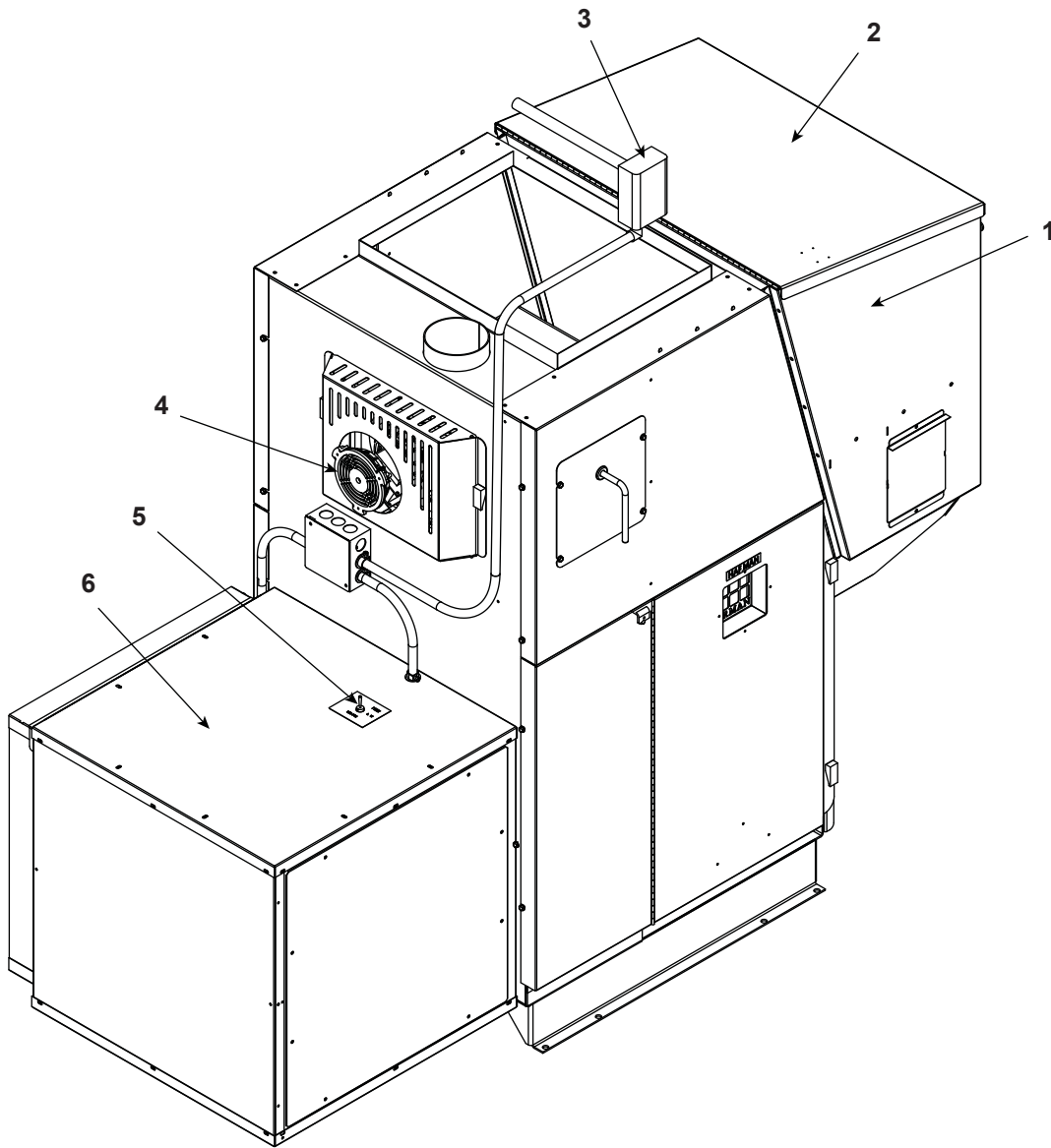

Part number list on following page.

IMPORTANT: THIS IS DATED INFORMATION. When requesting service or replacement parts for your appliance please provide model number and serial number. All parts listed in this manual may be ordered from an authorized dealer.



**Stocked at Depot**

ITEM	Description	COMMENTS	PART NUMBER	
1	Hopper Assembly	Pre 008350087	1-10-08224A	
		Post 008350087	1-10-73329	
2	Hopper Lid Assembly - Swell latch	Pre 008350087	1-10-73333A	
	Hopper Lid Assembly - Spring Latch	Post 008350087	1-10-73491A	
3	Fan Control / High limit		3-20-23139	Y
4	Combustion Blower		3-21-08639	Y
5	Toggle Switch - 3 Speed		3-20-70020	Y
6	Filter box kit		1-00-20201	

### #7 Feeder Assembly Pre SN 008350087

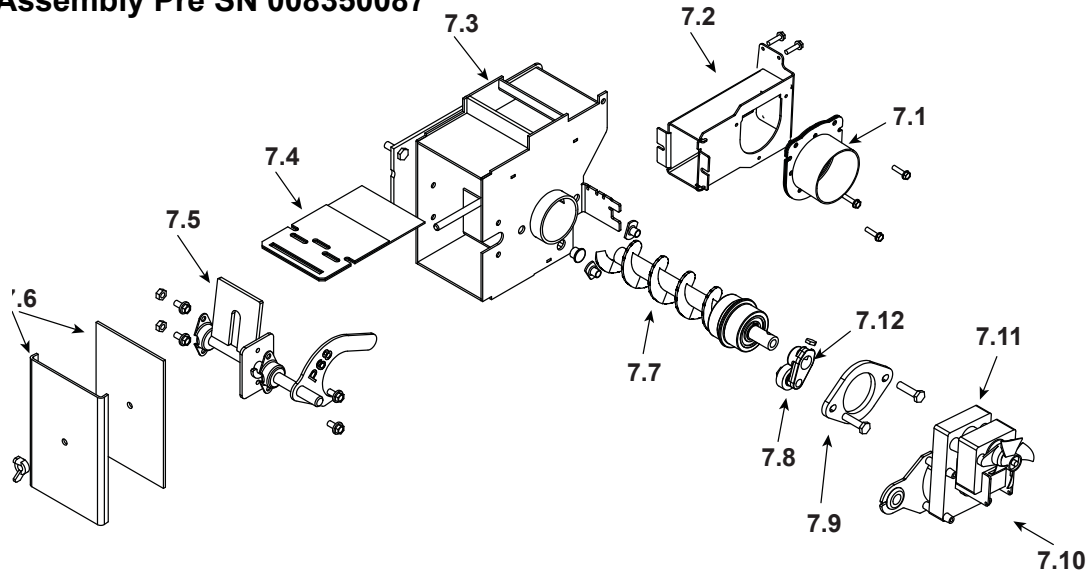

7.1	Air Intake Damper Assembly		1-10-06466W	
7.2	Air Intake Weldment		1-10-773843	
7.3	Feeder Weldment		1-10-677150	Y
7.4	Slide Plate Assembly		1-10-08037	Y
7.5	Pusher Arm Assembly		1-10-08048	Y
7.6	Feed Cover and Gasket	2 Sets	1-00-677152	Y
7.7	Auger Assembly		3-50-00465	Y
7.8	Cam Bearing		3-31-3014	Y
7.9	Bearing Flange w/Hardware		1-00-04035	Y
7.10	Bracket, Gear Motor	Pkg of 2	1-00-01534	Y
7.11	Gear Motor, 6 RPM		3-20-09302	Y
7.12	Cast Cam Block		3-00-00153	Y
	Gasket Feeder Air Intake	Pkg of 6	3-44-72224-6	Y

Additional service parts on following page.



IMPORTANT: THIS IS DATED INFORMATION. When requesting service or replacement parts for your appliance please provide model number and serial number. All parts listed in this manual may be ordered from an authorized dealer.

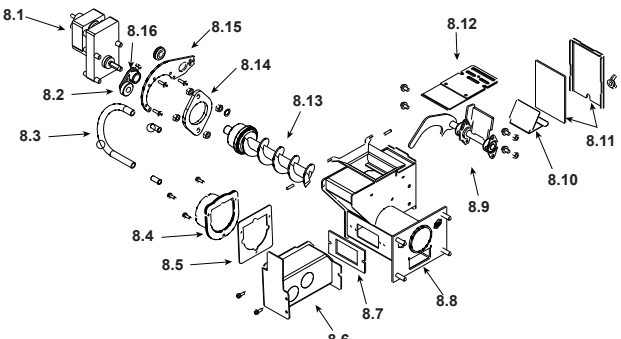

**Stocked at Depot**

ITEM	Description	COMMENTS	PART NUMBER	
<b>#8 Post Feeder Assembly</b> <b>SN #008350087</b> 				
8.1	Pellet Feeder Gear Motor, 10 RPM		3-20-02524	Y
8.2	UL Feeder Cam		3-31-3014	Y
8.3	9MM Silicone Tube		1-00-511427	Y
8.4	Pellet Air Intake Assembly		1-10-06810A	
8.5	Gasket Feeder Air Intake	Pkg of 6	3-44-72224-6	Y
8.6	UL Feeder Air Intake		1-10-72222	
8.7	Gasket Ultra Air Intake	Pkg of 10	3-44-677160-10	Y
8.8	Ultra Feeder Weldment		1-10-72226S	Y
8.9	UL Feeder Pusher Arm		1-10-677187W	Y
8.10	Fines Deflector	<b>No longer available</b>	2-00-677138-10	
8.11	Gasket, UL Feeder Cover		1-00-677122	Y
8.12	Slide Plate Assembly		1-10-677121A	Y
8.13	UL Feeder Auger Assembly		3-50-00565	Y
8.14	Bearing Flange w/Hardware		1-00-04035	Y
8.15	UL Feeder Gear Motor Bracket w/Grommet		1-00-247406	Y
8.16	UL Feeder Cam Block		3-00-677154	Y
	Gasket, HopperThroat		3-44-677185	
	A/C double Pole relay		3-20-38056	Y
	Air filter - 20 x 20 x 1	Pkg of 12	3-40-20201-12	
	Arrow Burn Pot Scraper	Pkg of 10	2-00-773850-10	
	Ash Pan		1-10-73351	Y
	Battery back-up		3-20-512	
	Bearing 3/8 ID x 1-1/8 OD		3-31-3014	Y
	Blower assembly 1450 Cfm		1-00-00862	Y
	Blower assembly 1638 Cfm		3-21-19599	Y
	Burn Pot Weldment		1-10-73546A	Y
	Cable 2 Pair twisted cat 3 (50' for wall control)		3-20-02583	
	Circuit Board		1-00-05888	Y
	Circuit breaker 10 Amp (orange - on/off switch)		3-20-334110	

Additional service parts on following page.

IMPORTANT: THIS IS DATED INFORMATION. When requesting service or replacement parts for your appliance please provide model number and serial number. All parts listed in this manual may be ordered from an authorized dealer.



**Stocked  
at Depot**

ITEM	Description	COMMENTS	PART NUMBER	
	Circuit breaker harness - to control board		3-20-04947	
	Comb blower heat shield		2-00-73339	
	Control Knob/ Shaft	25 Sets	1-00-015605	Y
	Differential Pressure Switch		3-20-6866	Y
	Distribution Blower assembly 1000 Cfm		1-10-01006	Y
	Distribution Blower mounting bracket	Qty 2 req	2-00-73430B	
	Distribution Blower (motor only) 1000 cfm		3-20-36648	Y
	ESP (Exhaust Sensing Probe)	Black wires	1-00-00744	Y
	ESP (Exhaust Sensing Probe)	Red wires	3-20-00844	Y
	Fan Blade, 5" Single Paddle (Combustion Blower)		3-20-40985	Y
	Fan Blade, 5" Double (high altitude)		3-20-502221	Y
	Fire Brick 12 x 6 x 1.25"		3-40-86125	Y
	Flame Guide		3-00-08534	Y
	Flame guide insulator		3-44-35263	Y
	Flex pipe 2-3/4" (12-1/2")		2-00-08544	
	Flex pipe 2-3/4" (25')		2-00-08545	
	Gasket, 1/4" Rope Black w/PSA per inch (Glass)		1-00-2312	Y
	Gasket, Ceramic Insert Plate	Post 004351831	3-44-724114	Y
	Gasket, Burn Pot	Pre 004351831	1-00-07381	Y
		Post 004351831	3-44-724115	Y
	Gasket, Chain shaker	Pkg of 2	3-44-08100-2	Y
	Gasket, Hopper Lid		1-00-00248	Y
	Gasket, Hopper Throat	Post 008350087	3-44-677185	Y
	Harman Gold Label	Pkg of 5	3-90-08540-5	
	Haman Silver Label	Pkg of 5	3-90-04580-5	
	Heat exchanger baffle - bottom		2-00-73314	Y
	Heat exchanger baffle - top		2-00-73418	
	Hopper lid catch		2-00-72166B	
	Hopper Muffler and Fittings	1 set	1-00-18186618	Y
	Ignition Air Pump	Post 004351831	3-20-02679	Y
	Ignitor Element (Pressure Ignition)	Post 004351831	3-20-00450	Y
	Ignitor Element	Pre 004351831	3-20-677200	Y
	Inner ash door gasket		1-00-00539	Y
	Inner ash door glass		3-40-5555	
	Junction box harness		3-20-04948	
	Low fuel sensor		4-20-03835	Y
	Outside Air Vent Assembly		1-10-09542	
	Terminal block for power supply - 3 Position		3-20-03018	Y
	Thermostat extension 4 Pole		3-20-04946	
	Thermostat (wall control)		3-20-08101	Y

# Testing Label

Tested & Listed By



Portland Oregon USA

OMNI-Test Laboratories, Inc.  
Report #/Rapport #135-S-02-2  
Certified for U.S.A. and Canada  
Certifié pour les États-Unis et le Canada

**PF 100**

LISTED PELLET FUEL CENTRAL OR SUPPLEMENTARY FURNACES FOR RESIDENTIAL USE

APPAREIL DE CHAUFFAGE CENTRAL OU SUPPLÉMENTAIRE ENREGISTRÉ DE BOULETTES COMBUSTIBLES POUR USAGE DANS LES RÉSIDENCES



Serial No.  
Numéro de série

**008**

Tested June 2001 to CAN/CSA B366.1-M91, UL 391, ASTM E 1509-04 & ULC C1482-M1990.

Install and use only in accordance with the manufacturer's installation/operating instructions. Refer to authorities having jurisdiction for proper installation. Contact local building or fire officials about restrictions and installation inspection in your area. If there are no applicable local codes, follow ANSI/NFPA 211 and CAN/CSA B365. Special precautions are required for passing the chimney through a combustible wall or ceiling. Inspect and clean exhaust venting system frequently in accordance with manufacturer's instructions. Use a 4" diameter type "L" or "PL" venting system.

A Harman PF 100 may be connected to an existing furnace or heat pump duct system.

Testé en Juin 2001 à CAN/CSA B366.1-M91, UL 391, ASTM E 1509-04 & ULC C1482-M1990.

Installez et utilisez en accord avec les instructions d'installation et d'opération du fabricant. Référez-vous à des professionnels avec autorité dans l'installation. Contactez le bureau de la construction ou le bureau des incendies au sujet des restrictions et de l'inspection d'installation dans votre voisinage. S'il n'y a pas de codes locaux, suivez alors ANSI/NFPA211 et CAN/CSA B365. Prenez des précautions spéciales lorsque vous faites passer une cheminée à travers un mur ou un plafond combustible. Inspectez et nettoyez le système de ventilation fréquemment en accord avec les instructions du fabricant. Utilisez un système de ventilation de 4" de diamètre de type "L" ou "PL".

Une Harman PF 100 peut être connecté à une fournaise ou un système de pompe de chauffage déjà existants.

Model Modèle	Fuel Combustible	Chimney Connector Size Grandeur du Tuyau de Cheminée	BTUH/Kw Input Pellet Rendement des Boulettes BTUH/Kw	Electrical Rating Classification Électrique	Maximum Overcurrent Protection Protection Maximum du Courant
PF 100	Pellet Boulettes	4"	112,625 BTUH (33 Kw)	120V, 9.3A, 60 Hz	20 AMP

**Clearances to Combustibles/Espaces Libres aux Combustibles**

Combustibles to Filter Box on Appliance	1" (25 mm)	Des combustibles à la boîte de filtration de l'appareil
Combustibles to Connector Pipe	*2" (51 mm)	Des combustibles au tuyau connecteur
Combustibles to Appliance	12" (305 mm)	Des combustibles à l'appareil
Supply Air Plenum to Ceiling	1" (25 mm)	Provision d'air plénum au plafond
Supply Air Plenum to Combustible Chase	1" (25 mm)	Provision d'air plénum au châssis du combustible
Appliance Body to Ceiling	28" (711 mm)	De l'appareil au plafond
Combustibles from Stove Front	36" (914 mm)	Des combustibles au devant du poêle

\* At 16" of pipe length distance from flue collar while maintaining listed clearances from appliance body./  
Un tuyau de grandeur de distance de 16" de l'ouverture du ventilateur doit être en accord avec l'espace libre mentionné de l'appareil même.

**Essential parts and subassemblies provided for field assembly are as follows /  
Pièces essentielles et sous-ensembles procurées pour l'assemblage sont les suivantes:**

Thermostat/Thermostat	Burnpot Scraper/Grattoir de la chaudière de chauffage
Datacom Wire/Fil datacom	1000 CFM Blower (Standard)/Ventilateur CFM 1000 (Standard)
Fan Control High Limit/Contrôle du ventilateur haute limite	1400 CFM Blower (Optional)/Ventilateur CFM 1400 (Optionnel)
Fire Brick/Brique de feu	Return Air Filter Box/Boîte de filtration pour retour d'air
Heat Exchanger Baffles/Défecteurs d'échange de chaleur	Ash Pan/Bassin des cendres

**DO NOT CONNECT THIS UNIT TO A CHIMNEY FLUE SERVING ANOTHER APPLIANCE**

**WARNING!** Do not operate with fire chamber or ash removal doors open. Do not store fuel or other combustible material within installation clearance area.

**CAUTION!** Hot while in operation.  
DO NOT touch. Keep children, clothing, furniture and other combustible material out of the installation clearance area.  
DO NOT connect this unit to a chimney flue that serves another appliance.  
Flooring must be a non-combustible material covering the installation clearance area, and 18" in front of, and 8" to either side of the fuel loading doors.

**In the event of loss of electrical power:**  
Consult owner's manual for restarting your furnace after power is restored.

**NE PAS CONNECTER CET APPAREIL À UN TUYAU DE CHEMINÉE SERVANT UN AUTRE APPAREIL**

**ATTENTION!** Ne pas opérer si la porte du combustible ou la porte de la cuvette des cendres sont ouvertes. Ne pas placer le combustible et les matières combustibles à l'intérieur de l'espace désignée pour l'installation.

**ATTENTION!** Chaud lors de l'opération.  
NE PAS toucher. Gardez les enfants, les vêtements, les meubles et les matériaux combustibles loin de l'espace désignée pour l'installation.  
NE PAS connecter cet appareil à un tuyau de cheminée servant un autre appareil.  
Le plancher de l'espace désigné pour l'installation doit être fait de matière non-combustible, de 18" en avant, et de 8" de chaque côté des portes d'entrée du combustible.

**Dans le cas d'un manque d'électricité:**  
Consultez le manuel du propriétaire pour remettre la fournaise en marche lorsque l'électricité est revenue.

Manufactured by/Fabriqué par: Hearth & Home Technologies, Inc.  
352 Mountain House Road, Halifax, PA 17032

Date of Manufacture/Date de Fabrication

2009 2010 2011 Jan Feb Mar Apr May Jun Jul Aug Sep Oct Nov Dec

Made in U.S.A./Fait aux États-Unis Do Not Remove or Cover This Label/Ne pas enlever ou recouvrir cet étiquette

# Warranty

## HARMAN™ CENTRAL HEATING PRODUCTS LIMITED WARRANTY

Hearth & Home Technologies Inc., on behalf of its Harman™ brand ("HHT"), extends the following warranty for all Harman™ furnace and boiler products ("Products") that are purchased from an HHT authorized dealer.

**Warranty Coverage:** Subject to the conditions, exclusions and limitations set forth below, HHT warrants to the original owner of the Products, and to any transferee taking ownership of the Products at the site of original installation within two years following the date of original purchase, that the Products will operate free from defects in material and workmanship under normal conditions and use, as described in the operating instructions furnished with the Product, during the warranty period described below. HHT will, at its option, repair or replace any Product covered by this warranty that is determined to be defective in material or workmanship.

**Warranty Period:** The warranty period runs for six years, except for mechanical and electrical components, which are warranted for three years. The warranty period begins on the earlier of: (i) the date of invoice for the Product; (ii) in the case of new home construction, the date of first occupancy of the residence or six months after the date of sale of the Product by an HHT authorized dealer, whichever occurs first; or (iii) the date 24 months following the date of Product shipment from HHT, regardless of the invoice or occupancy date.

**Warranty Conditions:** This warranty applies only to Products: (i) installed, operated, and maintained as recommended in the Product user's manual; (ii) purchased through an HHT authorized dealer; (iii) while remaining at the site of original installation; and (iv) that have not been altered after leaving the factory.

**How to File a Claim:** Claims must be made within the warranty period to the dealer who sold the Product. If that dealer cannot provide the warranty service, contact the nearest HHT authorized dealer. Additional service fees may apply if you are seeking warranty service from a dealer other than the dealer from whom you originally purchased the Product. Travel and shipping charges for parts are not covered by this warranty.

**Warranty Exclusions:** This warranty does not cover the following: (1) consumable and normal wear items, including, without limitation, flame guides, grates, coal bars, afterburner hoods, fire brick, gaskets, paint, glass discoloration, burnpot housing weldments, burnpot grate weldments (pellet or corn), burnpot front plates (pellet or corn), burnpot front plate locks, corn auger extensions, ceramic inserts, and ceramic insert plates; (2) noise caused by minor expansion, contraction or movement of parts; (3) damage resulting from: (i) failure to install, operate or maintain the Product according to the installation and operating instructions and listing agent identification label furnished with the Product; (ii) failure to install the Product according to local building codes; (iii) shipping or improper handling; (iv) abuse, misuse, continued operation with damaged, corroded or failed components, accident, or incorrectly performed repairs; (v) environmental conditions, inadequate ventilation, negative pressure or drafting caused by tightly sealed construction, insufficient make-up air supply, or handling devices such as exhaust fans or forced air furnaces or other such causes; (vi) use of fuels other than those specified in the operating instructions; (vii) installation or use of components or accessories not supplied with the Product or authorized and approved in writing by HHT; (viii) modification of the product not expressly authorized and approved by HHT in writing; or (ix) interruptions or fluctuations of electrical power supply to the Product; (4) non-HHT components or accessories used in conjunction with the Product; (5) the Products' capability to heat a desired space; information is provided to assist the consumer and the dealer in selecting the proper Product for the application; consideration must be given to Product location and configuration, environmental conditions, insulation and air tightness of the structure; or (6) additional or unusual utility bills incurred due to any malfunction or defect in Products.

**Limitations of Liability:** Repair or replacement in accordance with the provisions of this warranty will be the owner's exclusive remedy for and will constitute HHT's sole obligation under this warranty, under any other warranty (express or implied), or in contract, tort or otherwise. No employee, agent, dealer, or other person is authorized to give any warranty on behalf of HHT. TO THE EXTENT ALLOWED BY LAW, HHT MAKES NO OTHER WARRANTY, EXPRESS OR IMPLIED, INCLUDING ANY WARRANTY OF MERCHANTABILITY OR FITNESS FOR A PARTICULAR PURPOSE. HHT WILL NOT BE LIABLE FOR ANY CONSEQUENTIAL OR INCIDENTAL DAMAGES ARISING OUT OF DEFECTS IN OR USE OF THE PRODUCTS. Some states do not allow exclusions or limitation of incidental or consequential damages, so these limitations may not apply to you. This warranty gives you specific rights; you also may have other rights, which vary from state to state. The duration of any implied warranty is limited to the duration of the warranty period specified herein.

# Back-up Power Supply

This wiring schematic shows the optional use of a standard UPS (uninterrupted power supply). In the event of a power failure, this will provide power to the combustion blower to remove smoke and other exhaust gases from the furnace.

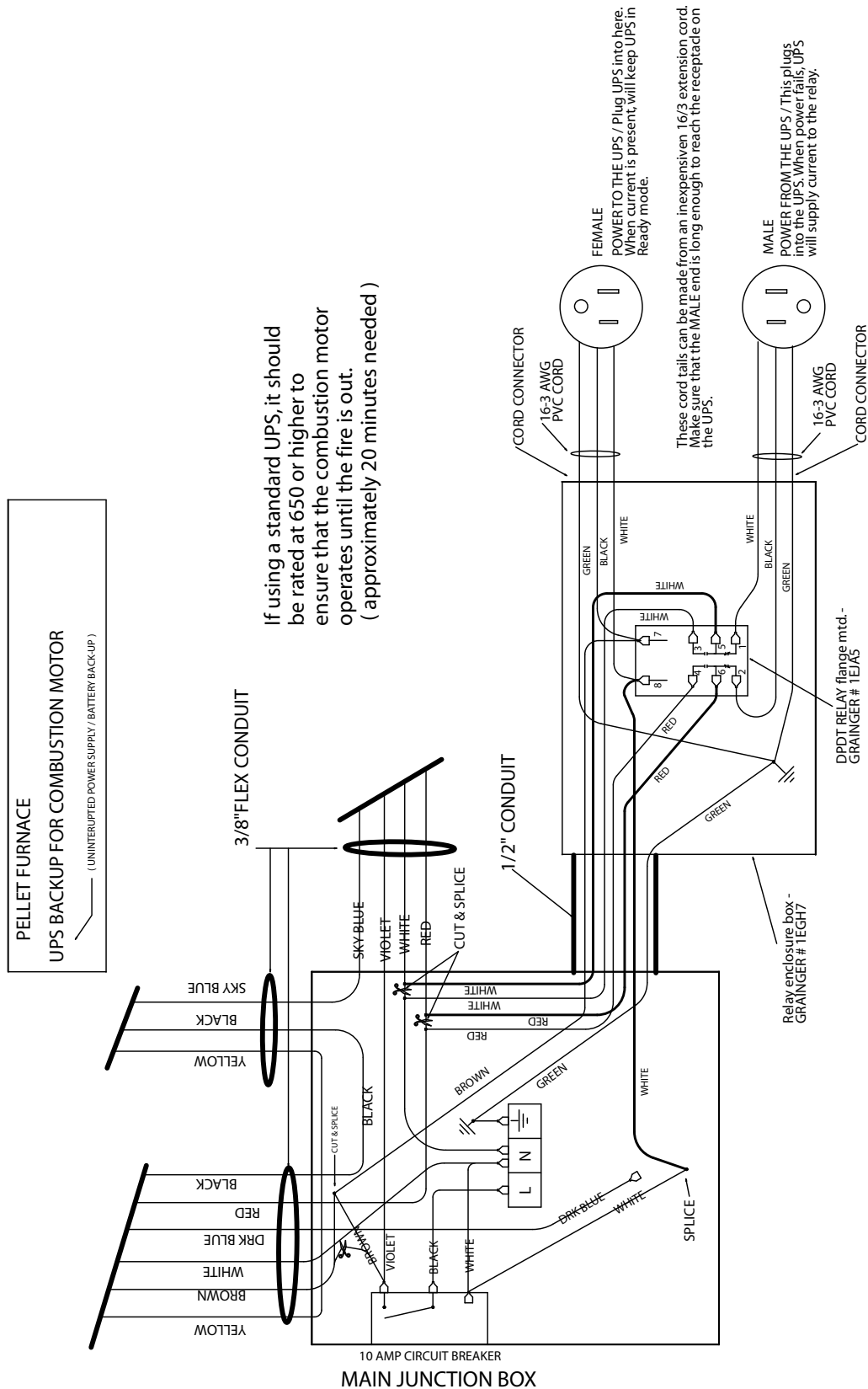

# Fuel Specifications

## Fuel and Fuel Storage

Pellet fuel quality can fluctuate from manufacturer to manufacturer, and even from bag to bag.

Hearth & Home Technologies recommends using only fuel that is certified by the Pellet Fuels Institute (PFI).

### Fuel Material

- Made from sawdust and/or other wood by-products
- Source material typically determines ash content

### Higher Ash Content Material

- Hardwoods with high mineral content
- Bark and leaves as source material
- “Standard” grade pellets, corn and other biomass

### Lower Ash Content Material

- Softwood; pine, fir, etc.
- Materials with lower mineral content
- “Premium” grade pellets

**CAUTION! Do not burn fuel that contains an additive; (such as soybean oil)**

- May cause hopper fire
- Damage to product may result

Read the list of ingredients on the packaging. If you are buying wood pellets, the only ingredient listed should be wood fiber or sawdust.

### Clinkers

Minerals and other non-combustible materials, like sand, will turn into a hard glass-like substance when heated. Trees from different areas will vary in mineral content. For this reason, some fuels will produce more clinkers than others.

### Moisture

Always burn dry fuel. Burning fuel with high moisture content takes energy to dry and tends to cool the appliance thus, robbing heat from your home. Damp pellet fuel could turn back into sawdust which does not flow properly through the feed system.

### Size

- Pellets are either 1/4 inch or 5/16 inch (6-8mm) in diameter
- Length should be no more than 1-1/2 inches (38mm)
- Pellet length can vary from lot to lot from the same manufacturer

### Performance

- Higher ash content requires more frequent maintenance.
- “Premium” grade pellets will produce the highest heat output.
- Burning pellets longer than 1-1/2 inches (38mm) can cause inconsistent feeding and/or ignition.

We recommend that you buy fuel in multi-ton lots whenever possible. However, we do recommend trying different brands prior to purchasing multi-ton lots, to ensure your satisfaction.

**CAUTION! Tested and approved for use with wood pellets ONLY. Burning of any other fuel will void your warranty.**

When changing from “Premium” grade pellets to a “Standard” or “Economy” grade fuel, the FEED ADJUSTER will likely need adjusted to a lower setting. When under maximum demand, ensure there is no unburned fuel being pushed into the ash pan.

### Storage

- Wood pellets should be left in their original sealed bag until ready to use, to prevent moisture.
- Do not store fuel within the specified clearance areas, or in a location that will interfere with routine cleaning and maintenance procedures.

## CAUTION

Tested and approved for use with wood pellets ONLY. Burning of any other fuel will void your warranty.

## NOTICE

Hearth & Home Technologies is not responsible for stove performance or extra maintenance required as a result of using fuel with higher ash or mineral content.

**HARMAN**<sup>TM</sup>  
**HOME HEATING**

**Proudly Printed On 100% Recycled Paper**



# Quick Reference ( Auto-Light )

- 1 Turn Mode Selector to OFF.
- 2 Use shaker handle to clean the heat exchanger tubes.\*\*
- 3 Scrape the air holes in the burnpot.\*\*
- 4 Fill the hopper with pellets.
- 5 Turn Feed Adjuster to “Test”.\*
- 6 Check the Combustion Blower and Feeder Motor for operation.\*
- 7 Turn Feed Adjuster back to the #4 setting.
- 8 Turn the Wall Control to the desired temperature.
- 9 Turn all of the Furnace Control knobs to the settings shown.\*
- 10 Flip the Auto-Light switch up.\*

The furnace will ignite if the temperature in the room is less than the temperature set on the Wall Control.

**\*See the section on Operation for information about Manual Lighting and Emergency Power.**

**\*\*See the section on Maintenance for more details about cleaning.**

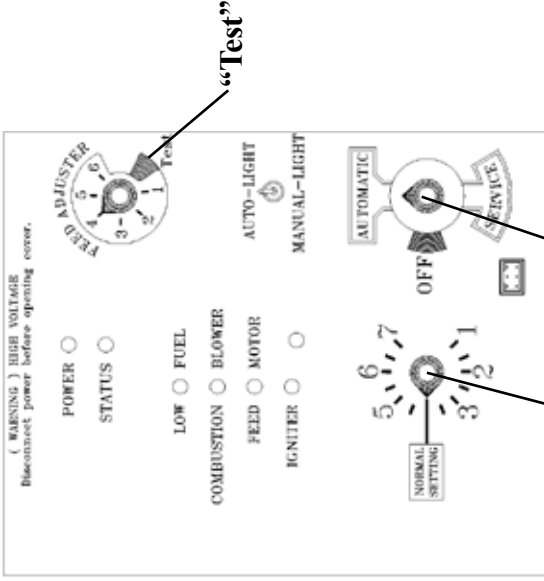

Temp Dial Mode Selector

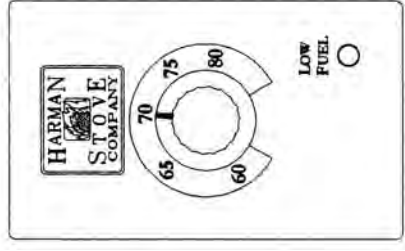

Wall Control