

# Installation & Operating Manual

## The Harman PC 45 Corn/Pellet Stove

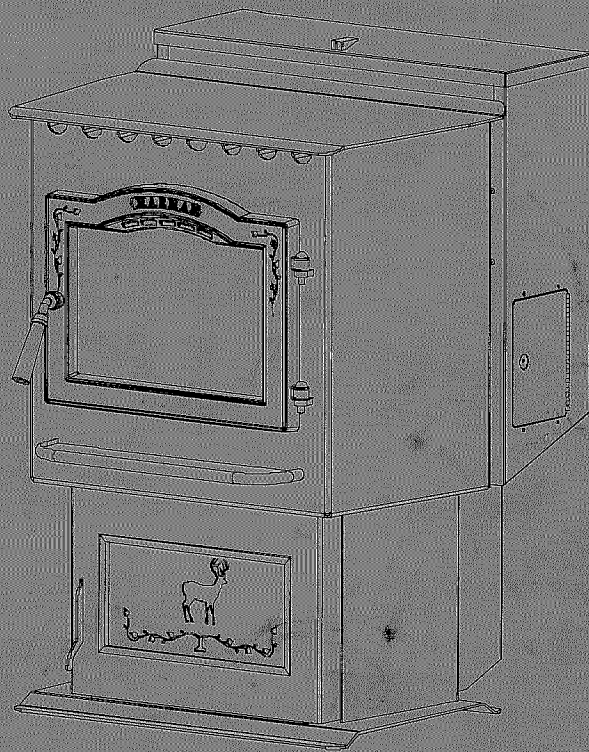

We suggest that our hearth products be installed and serviced by professionals who are certified in the U.S. by the National Fireplace Institute (NFI) as NFI Specialists.

*"Ce manuel est disponible en Français sur demande"*

R5

### SAFETY NOTICE

PLEASE READ THIS ENTIRE MANUAL BEFORE YOU INSTALL AND USE YOUR NEW ROOM HEATER. FAILURE TO FOLLOW INSTRUCTIONS MAY RESULT IN PROPERTY DAMAGE, BODILY INJURY, OR EVEN DEATH.

FOR USE IN THE U.S. AND CANADA. SUITABLE FOR INSTALLATION IN MOBILE HOMES

IF THIS HARMAN STOVE IS NOT PROPERLY INSTALLED, A HOUSE FIRE MAY RESULT. FOR YOUR SAFETY, FOLLOW INSTALLATION DIRECTIONS.

CONTACT LOCAL BUILDING OR FIRE OFFICIALS ABOUT RESTRICTIONS AND INSTALLATION INSPECTION REQUIREMENTS IN YOUR AREA.

CONTACT YOUR LOCAL AUTHORITY (SUCH AS MUNICIPAL BUILDING DEPARTMENT, FIRE DEPARTMENT, FIRE PREVENTION BUREAU, ETC.) TO DETERMINE THE NEED FOR A PERMIT.

CETTE GUIDE D'UTILISATION EST DISPONIBLE EN FRANCAIS. CHEZ VOTRE CONCESSIONNAIRE DE HARMAN STOVE COMPANY.

**SAVE THESE INSTRUCTIONS.**



# Assembly and Installation

## Unpacking

The PC 45 is bolted to the skid to prevent movement during shipping.

To free the stove from the skid you must remove the hold-down bolts in the rear of the pedestal base.

## Removing or Installing rear panels

To remove the rear cover panels, loosen the screws slightly and slide the covers outward as shown in figure 1. To reinstall, simply slide back into place and retighten the screws.

## Firebrick

Install the firebrick vertically on the angle above the burnpot.

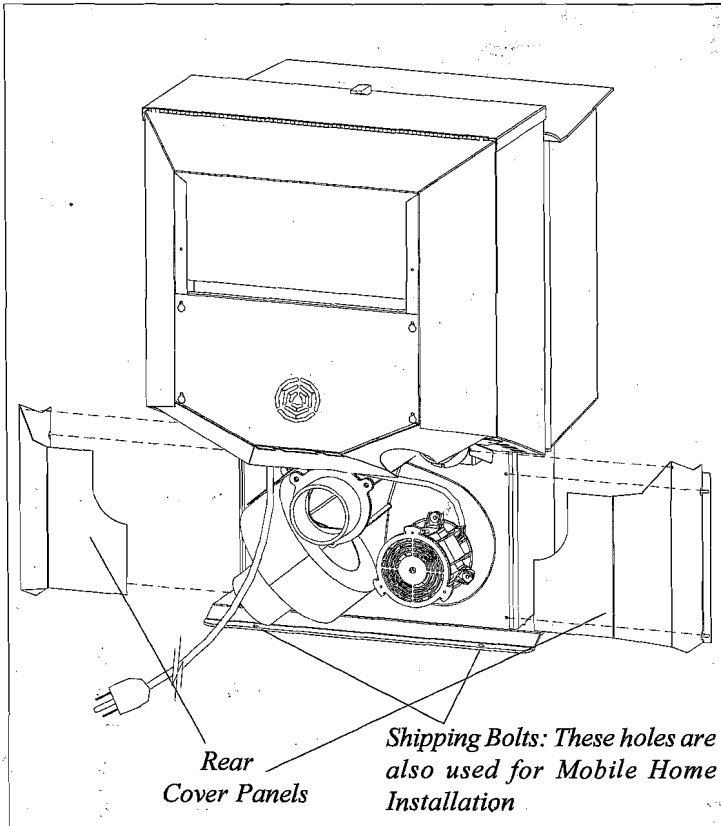

Fig. 1

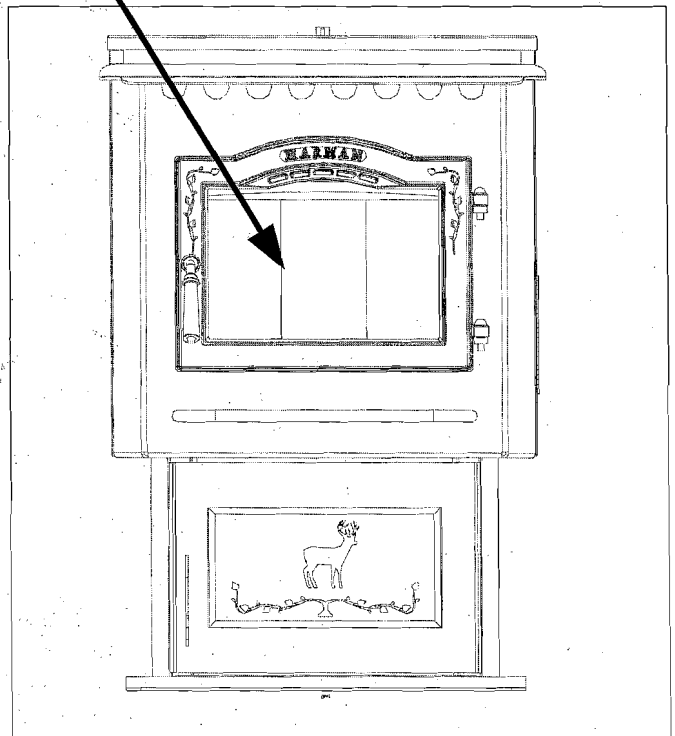

Fig. 2



# Installation

## Installing

Place the stove on a noncombustible floor protector that extends 6 inches to the front, 6 inches to the sides and 1 inch to the rear of the stove. The minimum floor protector material is 24 gauge sheet metal.

Place the stove away from combustible walls at least as far as shown in figures 3, 4 & 5. Please note the difference in side wall clearance with and without side shields.

Note that the clearances shown are minimum for safety but do not leave much room for access when cleaning or servicing. Please take this into account when placing the stove.

Connect the power cord to a 120 V.A.C. 60Hz grounded receptacle. (A surge protector is recommended to protect the circuit board).

Prior to installing the flue pipe, connect a draft meter to the stove as shown in fig. 6. (The draft meter must have a minimum range of 0"-0.5"). Turn stove to "TEST" Mode and record the draft reading \_\_\_\_\_. After the flue pipe is connected, check the draft reading again making sure all doors and windows in the home are closed. If this reading is more than .05" higher than the unconnected reading, check for possible restrictions or the need for outside air. (See page 7).

## Mobile Home Installation

When installing this unit in a mobile home several requirements must be followed:

1. The unit must be bolted to the floor. This can be done with 1/4" lag screws through the 2 holes in the base plate.
2. The unit must also be connected for the outside air. See page 8.
3. Floor protection and clearances must be followed as shown.
4. Unit must be grounded to the metal frame of the mobile home.

**CAUTION: This appliance must be vented to the outside.**

Due to high temperatures, the stove should be placed out of traffic and away from furniture and draperies.

Children and adults should be alerted to the hazards of high surface temperatures and should stay away to avoid burn to skin and/or clothing.

Young children should be carefully supervised when they are in the same room as the stove.

Clothing and other flammable materials should not be placed on or near this unit.

Installation and repair of this Harman Stove should be done by a qualified service person. The appliance should be inspected before use and at least annually by a qualified service person. More frequent cleaning will be required. It is imperative that control compartments, burners, and circulating air passageways of the stove be kept clean.

Mobile home installation should be done in accordance with the Manufactured Home and Safety Standard (HUD), CFR 3280, Part 24.

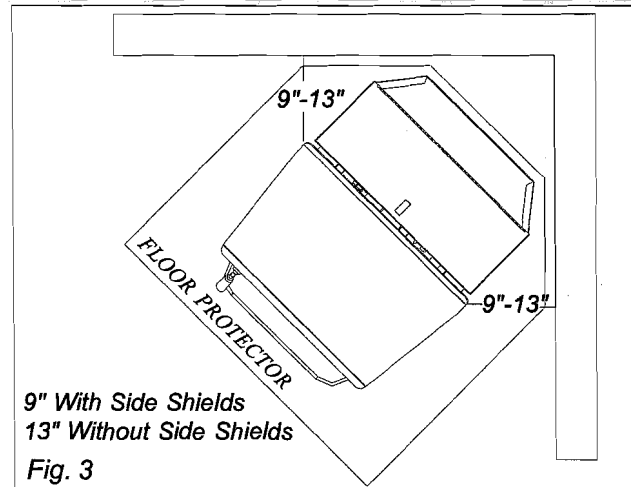

9" With Side Shields  
13" Without Side Shields  
Fig. 3

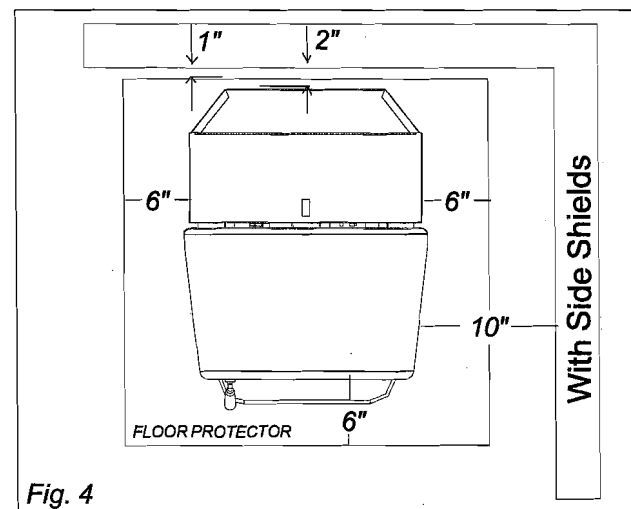

Fig. 4

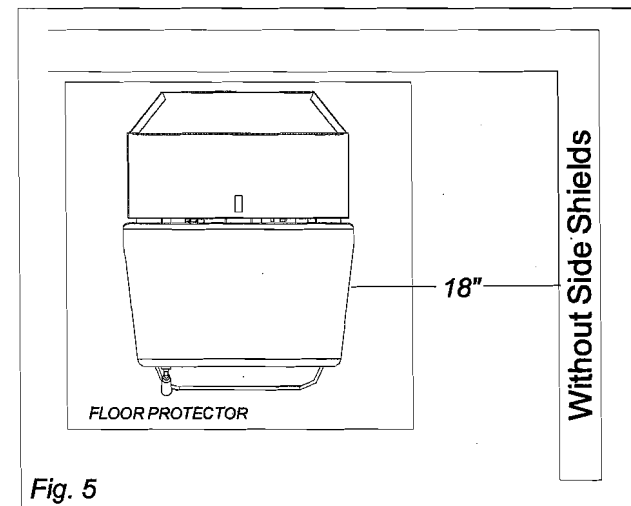
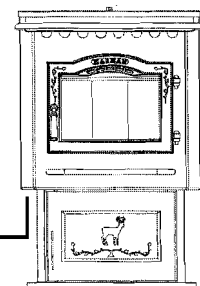

Fig. 5

Fig. 6: Refer to page 17 for detailed draft settings and adjustment procedures.



# Venting

## Requirements for Terminating the Venting

**WARNING:** Venting terminals must not be recessed into a wall or siding.

**NOTE:** Only PL vent pipe wall pass-throughs and fire stops should be used when venting through combustible materials.

**NOTE:** Always take into consideration the effect the prevailing wind direction or other wind currents will cause with flyash and /or smoke when placing the termination.

**In addition, the following must be observed:**

A. The clearance above grade must be a minimum of 18".<sup>1</sup>

B. The clearance to a window or door that may be opened must be a minimum of 48" to the side, 48" below the window/door, and 12" above the window/door.<sup>1</sup> (**With outside air installed clearances are 18" to the side, 18" below the window/door, and 9" above the window/door.**)

C. A 12" clearance to a permanently closed window is recommended to prevent condensation on the window.

D. The vertical clearance to a ventilated soffit located above the terminal within a horizontal distance of 2 feet (60 cm) from the center-line of the terminal must be a minimum of 18".

E. The clearance to an unventilated soffit must be a minimum of 12".

F. The clearance to an outside corner is 11" from center of pipe.

G. The clearance to an inside corner is 12".

H. A vent must not be installed within 3 feet (90 cm) above a gas meter/regulator assembly when measured from the horizontal center-line of the regulator.<sup>1</sup>

I. The clearance to service regulator vent outlet must be a minimum of 6 feet.<sup>1</sup>

J. The clearance to a non-mechanical air supply inlet to the building or the combustion air inlet to any other appliance must be a minimum of 48".<sup>1</sup>

K. The clearance to a mechanical air supply inlet must be a minimum of 10 feet.<sup>1</sup>

**(with outside air installed, 6 feet)**

L. The clearance above a paved sidewalk or a paved driveway located on public property must be a minimum of 7 feet.<sup>1,2</sup>

M. The clearance under a veranda, porch, deck or balcony must be a minimum of 12 inches.<sup>1,3</sup>

**NOTE:** The clearance to vegetation and other exterior combustibles such as mulch is 36" as measured from the center of the outlet or cap. This 36" radius continues to grade or a minimum of 7 feet below the outlet.

<sup>1</sup>Certain Canadian and or Local codes or regulations may require different clearances.

<sup>2</sup>A vent shall not terminate directly above a sidewalk or paved driveway which is located between two single family dwellings and serves both dwellings.

<sup>3</sup>Only permitted if veranda, porch, deck, or balcony is fully open on a minimum of 2 sides beneath the floor.

**NOTE: Where passage through a wall, or partition of combustible construction is desired, the installation shall conform to CAN/CSA-B365. (if in Canada)**

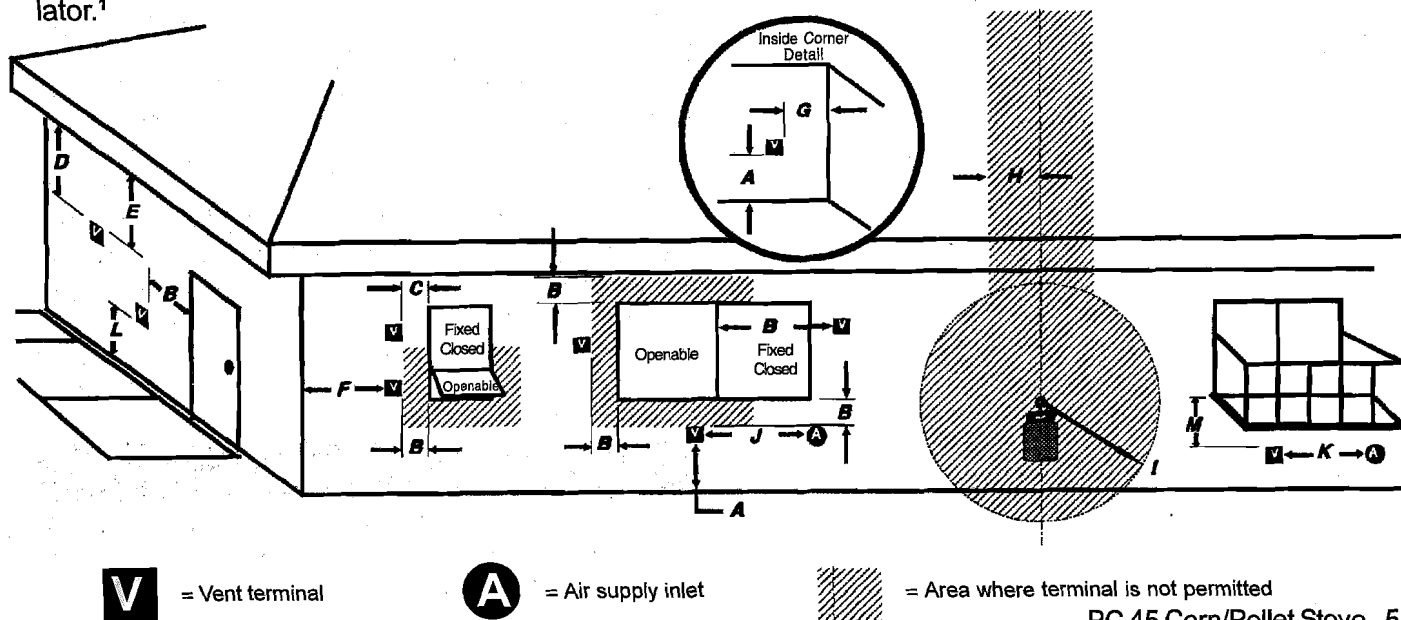

# Venting

## IMPORTANT NOTICE

Pellet Vent Pipe or PL Vent Pipe Must be used.

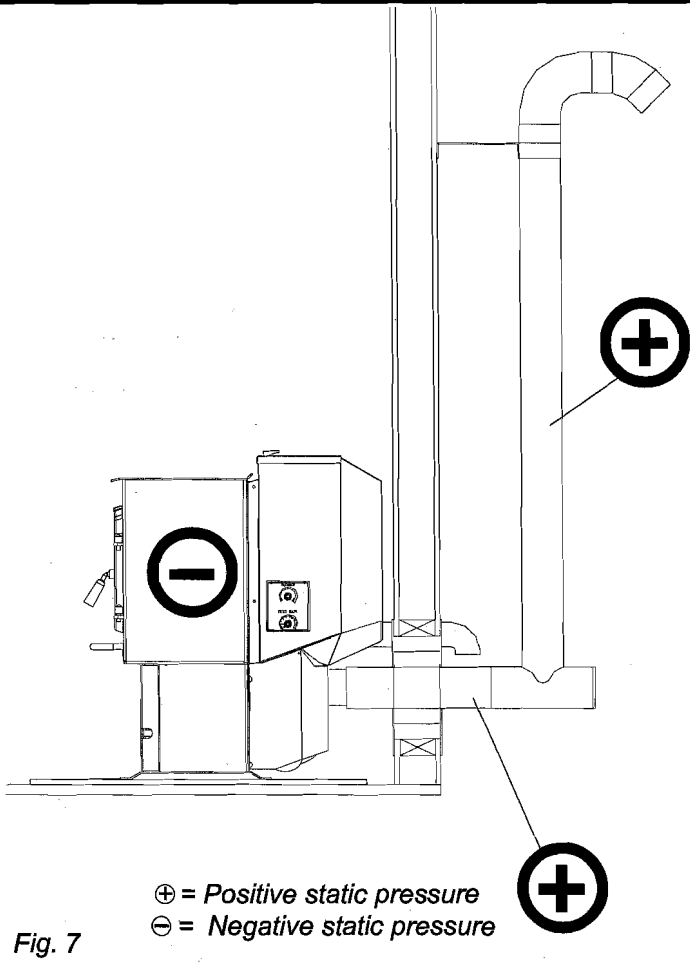

Fig. 7

A combustion blower is used to extract the combustion gases from the firebox. This causes a negative pressure in the firebox and a positive pressure in the venting system as shown in fig. 7. The longer the vent pipe and more elbows used in the system, the greater the flow resistance. Because of these facts we recommend using as few elbows as possible and 15 feet or less of vent pipe. The maximum horizontal run should not exceed 48". If more than 15 feet of pipe is needed, the diameter should be increased from 3" to 4" because a larger pipe creates less flow resistance. **Be sure to use approved pellet vent pipe wall and ceiling pass through fittings to go through combustible walls and ceilings.** Be sure to use a starting collar to attach the venting system to the stove. **The starting collar must be sealed to the stove with high temp silicone caulking.**

## Vent Pipe

Pellet venting pipe ( also known as PL vent ) is constructed of two layers with air space between the layers. This air space acts as an insulator and reduces the outside surface temperature to allow a clearance to combustibles of only 3 inches. The sections of pipe lock together to form an air tight seal in most cases; however, in some cases a perfect seal is not achieved. For this reason and the fact that the PC45 operates with a positive vent pressure we specify that the joints also be sealed with clear silicone.

## Outside Air

Outside air is optional except in mobile homes and where building codes require. The benefit of outside air is mainly noticed in small very tight houses.

To install outside air use 2 3/8" I.D. flex pipe part number 2-00-08543. There is a break-away hole on the rear panel which must be removed before connecting the flex pipe. The pipe should be run outside and terminate 3 feet or more to the side or below the vent pipe outlet. Never terminate the outside air above the vent pipe outlet. The maximum length run of this pipe is 15 feet. If a longer run is needed the size must be increased to 3". Inlet cover part number 1-10-08542 should be used to keep birds, rodents etc. out of pipe.

## HRV

When installing in a house with a Heat Reclaiming Ventilation System (HRV) be sure the system is balanced and is not creating a negative pressure in the house.

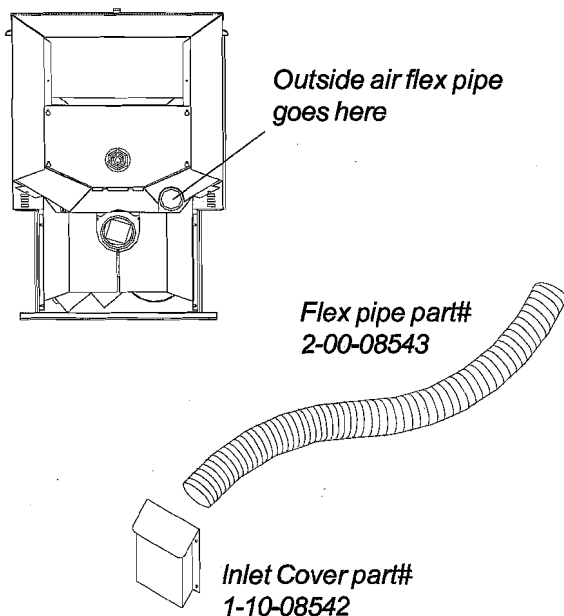

Fig. 8

# Venting

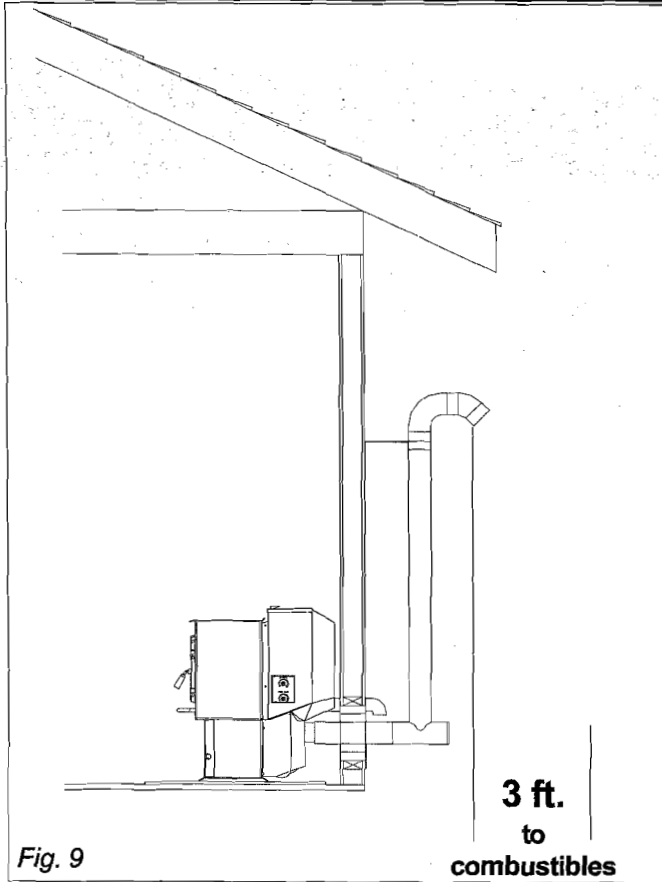

Fig. 9

## #1 Preferred method

This method provides excellent venting for normal operation and allows the stove to be installed closest to the wall. Two inches from the wall is safe; however, four inches allows better access to remove the rear panel. The vertical portion of the vent should be three to five feet high. This vertical section will provide natural draft in the event of a power failure.

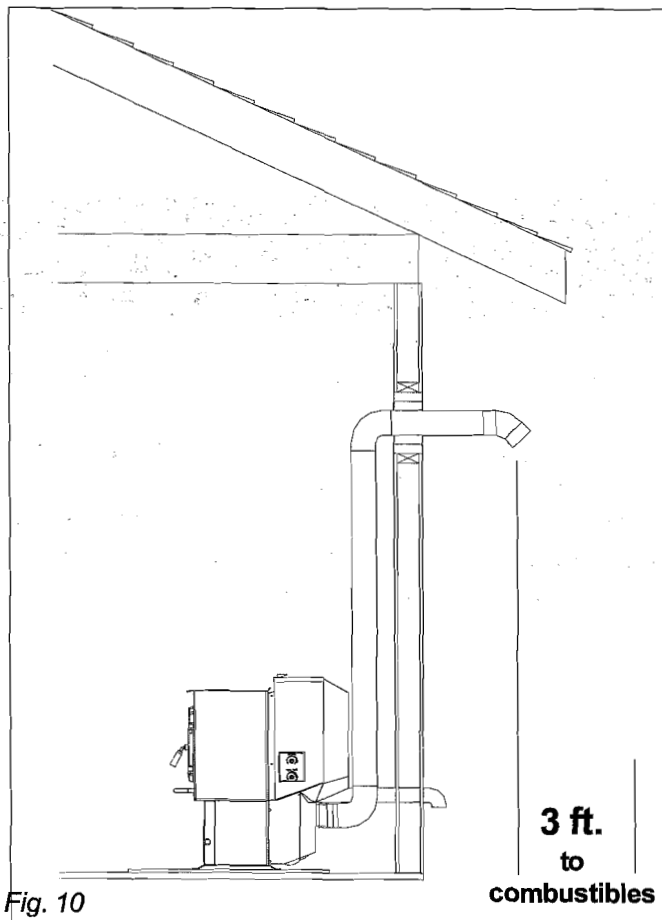

Fig. 10

## #2 Preferred method

This method also provides excellent venting for normal operation but requires the stove to be installed farther from the wall. The vertical portion of the vent should be three to five feet high and at least three inches from a combustible wall. This vertical section will provide natural draft in the event of a power failure.

If the stove is installed below grade the vent termination should be at least 1 foot above grade.

### CAUTION

Keep combustible materials (such as grass, leaves, etc.) at least 3 feet away from the flue outlet on the outside of the building.

# Venting

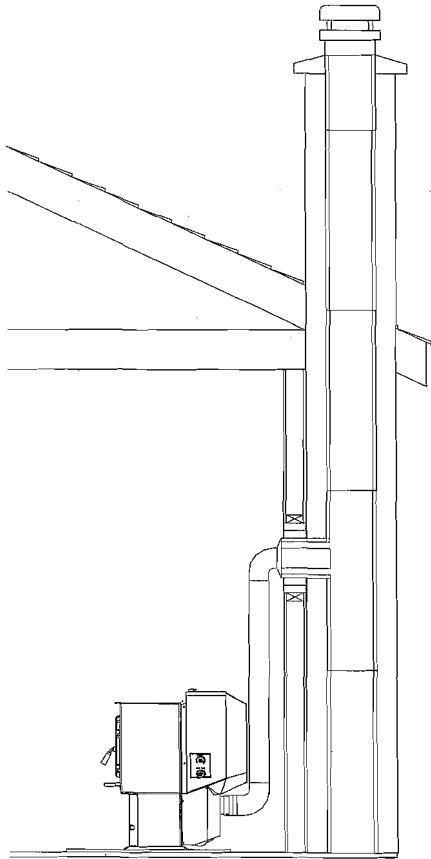

Fig. 11

## #3 Installing into an existing chimney ( US only )

This method provides excellent venting for normal operation. This method also provides natural draft in the event of a power failure. If the chimney condition is questionable you may want to install a liner as in method #6.

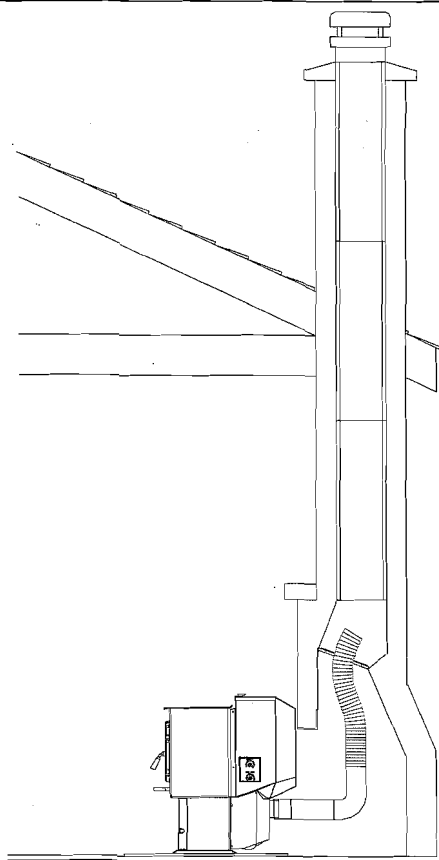

Fig. 12

## #4 Installing into an existing fireplace chimney ( US only )

This method provides excellent venting for normal operation. This method also provides natural draft in the event of a power failure.

The damper area must be sealed with a steel plate or fiberglass. A cap should be installed on the chimney to keep out rain. If the chimney condition is questionable you may want to install a liner all the way to the top as in method #5.



# Venting

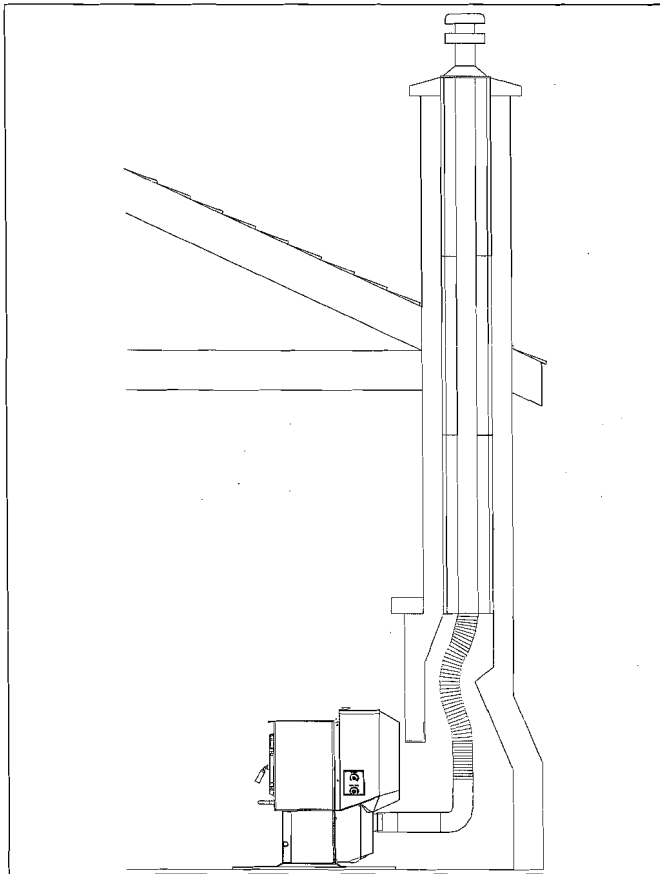

Fig. 13

## #5 Installing into an existing fireplace chimney (US and Canada)

This method provides excellent venting for normal operation. This method also provides natural draft in the event of a power failure.

In Canada and some places in the US it is required that the vent pipe extend all the way to the top of the chimney.

In this method a cap should also be installed on the chimney to keep out rain. Be sure to use approved pellet vent pipe fittings. Seal pipe joints with silicone in addition to the sealing system used by the manufacturer. Pipe size should be increased to 4" using this method.

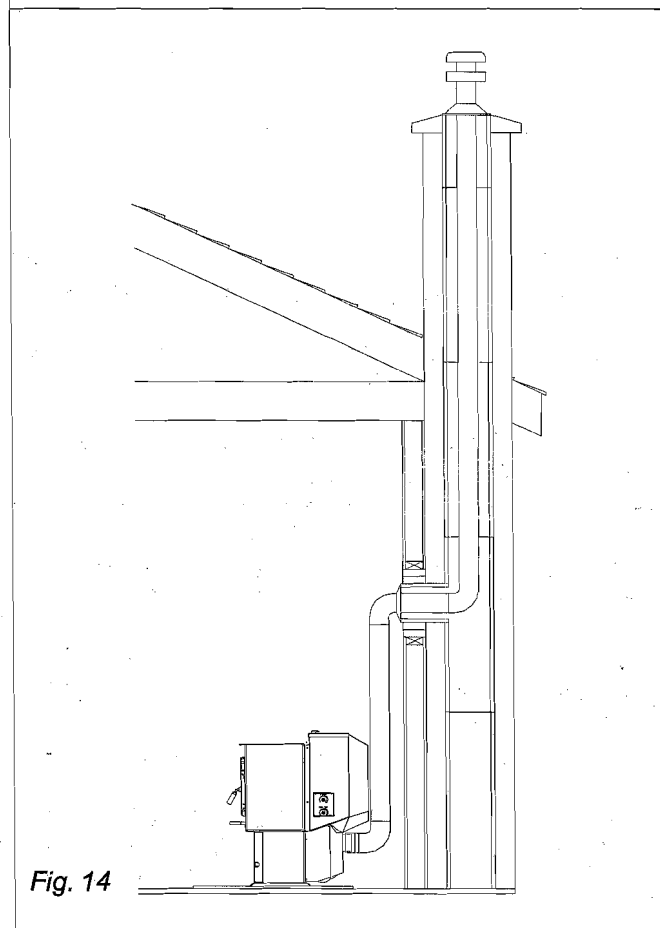

Fig. 14

## #6 Installing into an existing chimney ( US and Canada )

This method provides excellent venting for normal operation. This method also provides natural draft in the event of a power failure.

In Canada and some places in the US it is required that the vent pipe extend all the way to the top of the chimney. The pipe or liner inside the chimney should be 4" diameter.

In this method a cap should also be installed on the chimney to keep out rain.

# Venting

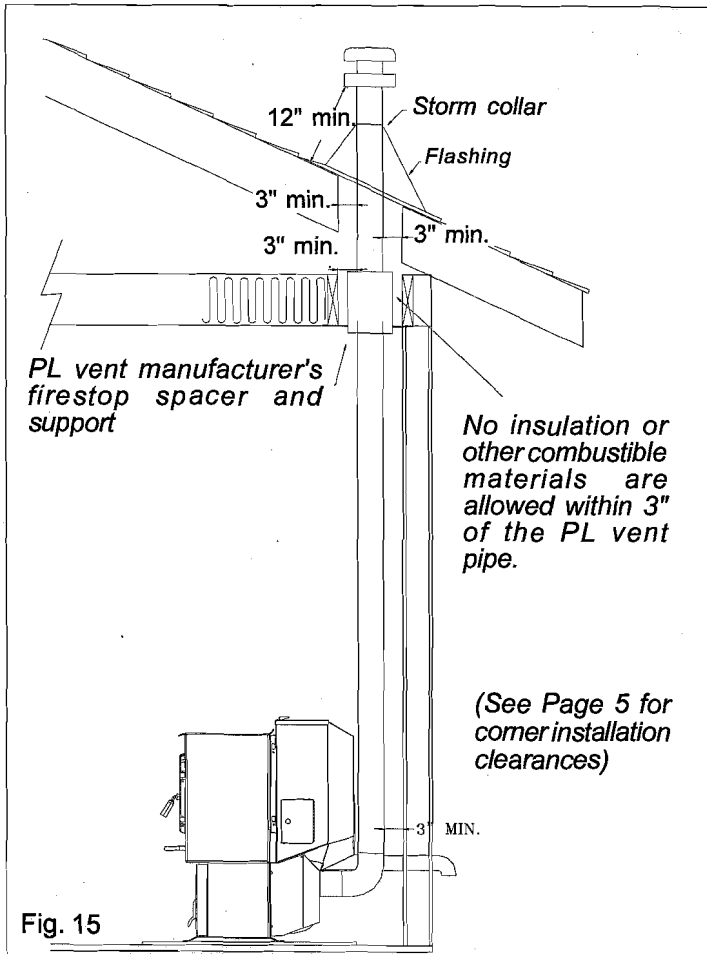

Fig. 15

## #7 Installing through the ceiling vent

Through the ceiling vent, follow PL vent manufacturers recommendations when using wall and ceiling pass through.

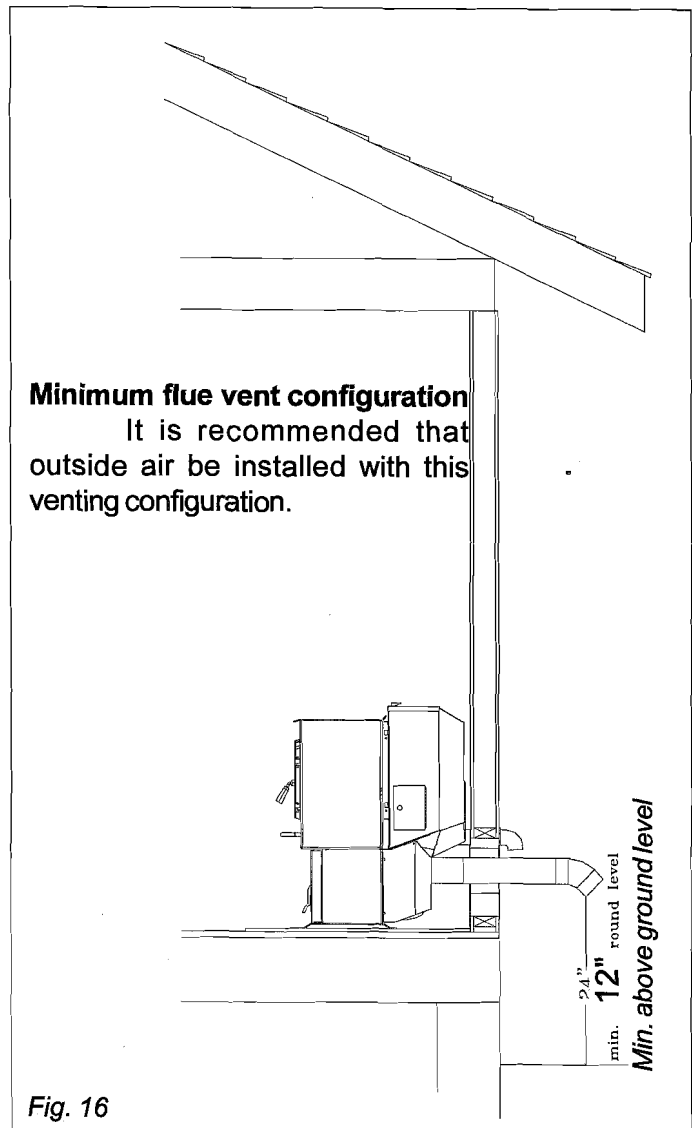

Fig. 16

**DO NOT INSTALL A FLUE DAMPER IN THE EXHAUST VENTING SYSTEM OF THIS UNIT.**

**DO NOT CONNECT THIS UNIT TO A CHIMNEY FLUE SERVING ANOTHER APPLIANCE.**

**INSTALL VENT AT CLEARANCES SPECIFIED BY THE MANUFACTURER**

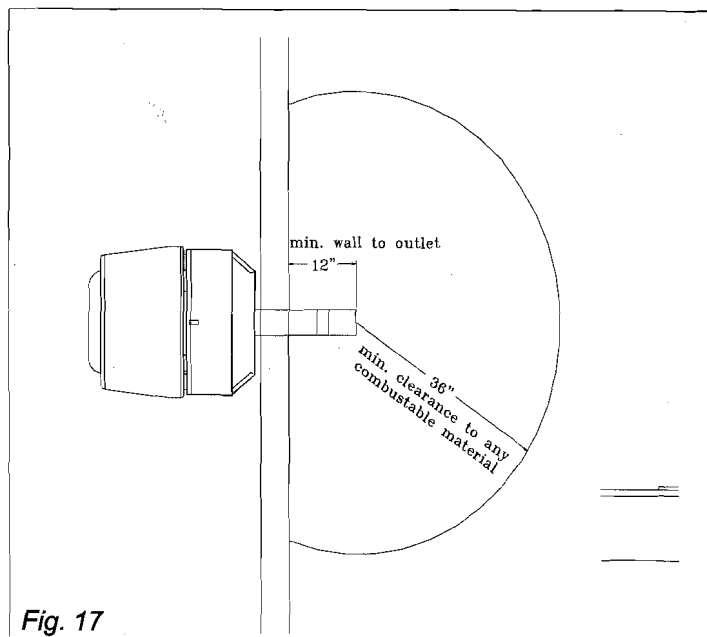

Fig. 17

**WARNING**  
**DO NOT INSTALL IN SLEEPING ROOM**

**CAUTION**  
**THE STRUCTURAL INTEGRITY OF THE MOBILE HOME FLOOR, WALL, AND CEILING/ ROOF MUST BE MAINTAINED.**

**CAUTION**  
**THE STOVE IS HOT WHILE IN OPERATION. KEEP CHILDREN, CLOTHING AND FURNITURE AWAY. CONTACT MAY CAUSE SKIN BURNS.**

# Grain Cap Installation

The grain cap is designed to enhance the burn quality of the fuel being burned (i.e. field corn, wheat, barley, rye, oats, etc.) Its purpose is to reflect more heat into the burn pot. This promotes a more thorough burning of the fuel and less ash. Depending on the quality of the fuel being burned, the effectiveness of the grain cap may vary.

The grain cap will need to be removed for cleaning. This part is classified as a consumable item and is excluded from the Harman Gold Warranty.

## **Installation:**

1. Hook the slot on the grain cap over the lip on the side rail of the burnpot, as shown on left.
2. Allow the grain cap to rest onto the burnpot sides.

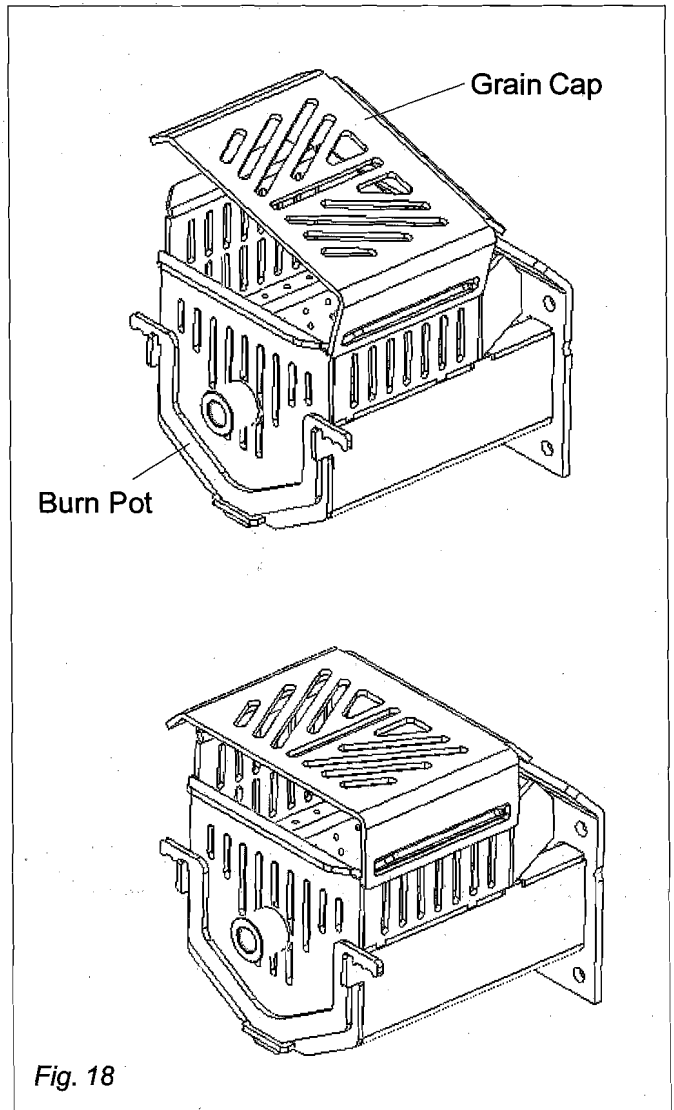

Fig. 18

# AUTOMATIC IGNITION/OPERATION

The PC45 corn/pellet stove is more than just automatic ignition, it is also automatic temperature control. The automatic system will allow the fire size to be adjusted to match the heating needs and even put the fire out if necessary. If heat is needed after the fire is out, the PC 45 will automatically re-ignite and adjust the fire size to match the heating need. The totally automatic room sensor mode is recommended because of its efficiency. The unit can be switched between "AUTO" and "MANUAL" at any time during operation.

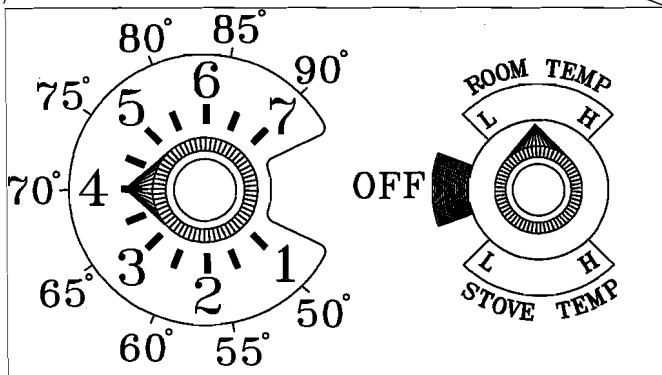
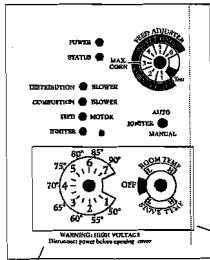

Fig. 19: **Room Temperature Mode:** This setting will produce a room temperature of 70 degrees with the distribution blower at medium speed.

## Igniter switch to "AUTO" Room Temperature Mode

In "Room Temp Mode" heat output is controlled automatically by the Room Sensing Probe. When the Room Sensing Probe calls for heat, the stove will increase output. When the Room Sensing Probe is getting close to the set temperature, the stove will begin to level off output and keep the fire burning at just the right temperature to maintain that setting.

High output is determined by the feed rate setting. This setting, generally on #2 (corn) or #4 (pellet), can be increased if higher burn rates are necessary.

When burning corn the feed rate setting can be adjusted anywhere within the yellow range with a #3 setting being the maximum setting, #1 the lowest setting. This setting will vary depending on the quality of corn used.

When burning pellets the feed rate setting can be adjusted within the full range between #1 on the low side to #6 on the high side.

Overfeeding is not a safety concern, but the fire may be pushed off the burnpot and extinguish in the ash pan.

In "Room Temp Mode" a constant fuel consumption rate is sacrificed for exact room temperature. Therefore, as it gets colder more fuel will be burned automatically.

The distribution blower speed will vary according to the position of the mode selector pointer, and fire size.

## Stove Temperature Mode

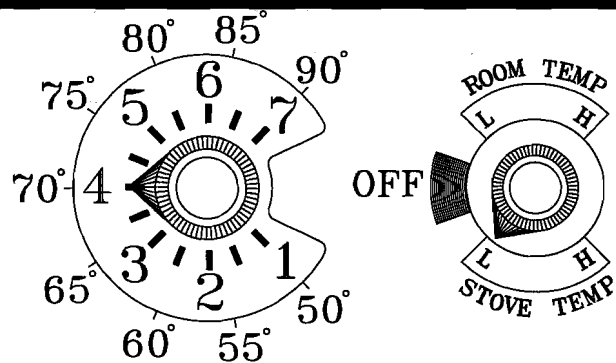

This setting will produce medium heat with the distribution blower on "low".

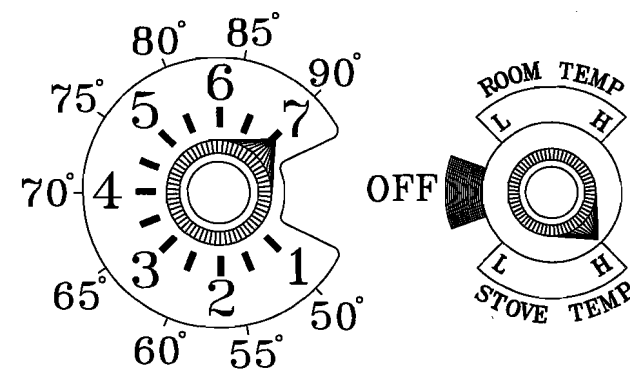

Fig. 20: This setting will produce continuous maximum heat output with the distribution blower at full speed.

## Igniter switch to "AUTO" Stove Temperature Mode

This allows for automatic ignition upon start-up only. The unit can then be set at any desired setting. The heat output and fuel consumption will remain constant regardless of room temperature.

The unit's low burn or maintenance setting is as low as it will go. It will not go out unless it runs out of fuel or is turned off.

## Shut-Down Procedure

To kill the fire or stop burning the stove, turn the Mode Selector to "OFF". This will cause the fire to diminish and burn out. When the fire burns out and the stove cools down everything will stop. **NOTE: The combustion blower motor will run for 5 hours after the stove is completely cool.** This insures that all fuel in the burnpot and ashes located in the ash pan are completely cold before shut down of the combustion motor.

If you pull the plug to shut down the stove, all motors will stop. This may cause incomplete combustion and smoke in the firebox. If the load door is opened the smoke may escape.

The best way to shut down the stove is simply let it run out of fuel, then the stove will shut down automatically.

# AUTOMATIC START UP

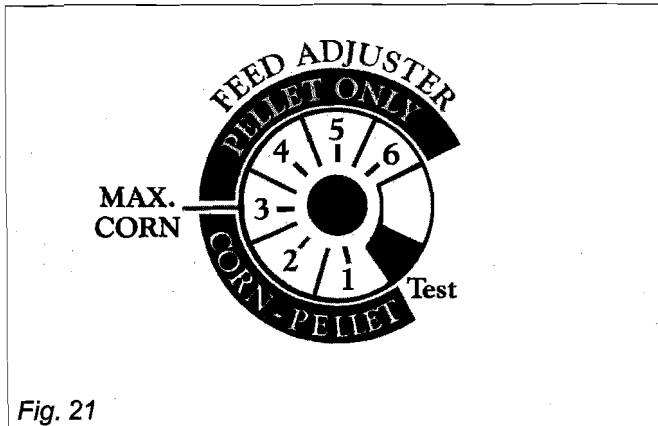

Fig. 21

## Starting the Fire

Igniter Switch to "AUTO" (up position)

Make sure the unit is plugged into a 120 VAC, 60 HZ electrical source. The power light should be the only light lit. Anytime there is interruption in power at the receptacle, the combustion blower will run for 1 minute after the power is regained.

1. Turn the Mode Selector to "OFF"
2. Fill the hopper with corn or pellets.
3. Clean the burn pot and housing, if necessary.
4. If starting after an empty hopper, turn the feed adjuster to "TEST" until the fuel is visible in the auger tube opening. This also allows you to check the motors for operation.  
NOTE: The auger motor will not operate with the view door or ash door open.  
NOTE: The initial start-up on a new stove may require the corn to be purged into the burnpot area before continuing to step 5.
5. Turn the feed adjuster to #2 (corn) or #4 (pellet)
6. Flip the igniter switch up into the "AUTO" position.
7. Turn the temperature dial to the desired room temperature.
8. Turn the mode selector dial to Room Temperature or Stove Temperature.
9. Fill the hopper with corn or pellets and remove the ashes as required.

## Warning

**"NEVER USE GASOLINE, GASOLINE-TYPE LANTERN FUEL, KEROSENE, CHARCOAL LIGHTER FLUID, OR SIMILAR LIQUIDS TO START OR "FRESHEN UP " A FIRE IN THIS HEATER. KEEP ALL SUCH LIQUIDS WELL AWAY FROM THE HEATER WHILE IN USE".**



# MANUAL IGNITION/OPERATION

The PC45 Corn/Pellet Stove is capable of manual operation. This also allows the operator to manually control operation during an emergency (i.e. ignitor failure, when using a 502H battery backup, or when using certain generators.)

The unit can be switched between "AUTO" and "MANUAL" at any time during operation.

**NOTE:** When starting the unit in the "AUTO" mode and switching to "MANUAL", the fire must be large enough to turn the ignitor light off (located on the control board). This is a signal that the start cycle is completed and the fire will not go out.

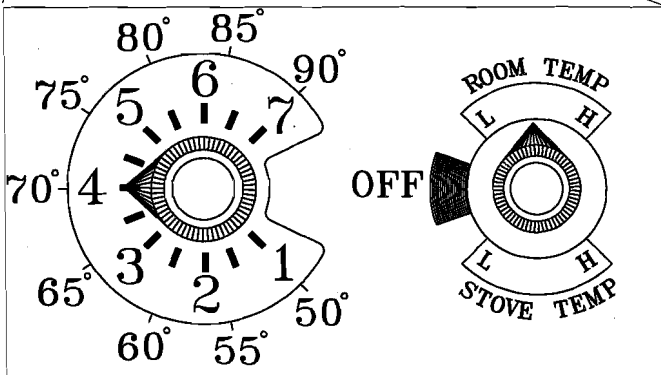
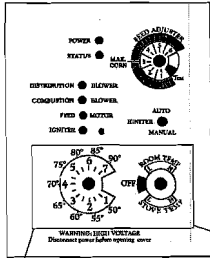

Fig. 22: Room Temperature Mode: This setting will produce a room temperature of 70 degrees with the distribution blower at medium speed.

## Igniter Switch to "MANUAL"

### Room Temperature Mode

The fire will have to be lit with starting gel and a match, or started automatically, see "Automatic Operation". Turn to "Manual" position when the fire is established.

The difference between "AUTO" Room Temperature Mode and "Manual" Room Temperature Mode is that the fire will not go out as the room temperature goes above the control board setting. The unit can only go to low burn and will remain there until it runs out of fuel or until more heat is needed and the feed rate increases. Feed rate adjustments and dial settings are the same as "AUTO" settings.

## Igniter Switch to "MANUAL"

### Stove Temperature Mode

The advantage of this mode is to allow the operator to have a large viewing fire without blowing extra heat into the room.

During operation, with the temperature dial set at #5 or less, the distribution fan will not operate. A #5 on the temperature dial and a #5 on the feed adjuster is approximately 80% output. It is not necessary to operate the distribution blower below this point. Therefore, there can be a higher feed rate ( a larger viewing fire) without an excess of hot air blowing into the room.

An example of when to use the Manual Stove Temperature Mode is if you want to watch a large fire and the room is already up to temperature. The Stove Temperature Mode allows you to have a larger fire and a lower sound level, without the distribution blower.

**NOTE:** During the use of this mode, if you keep increasing the temperature dial setting to increase the fire size, the distribution blower will automatically come on when the ESP Temperature reaches 350° F, or 81% output.

## Manual Stove Temperature Mode

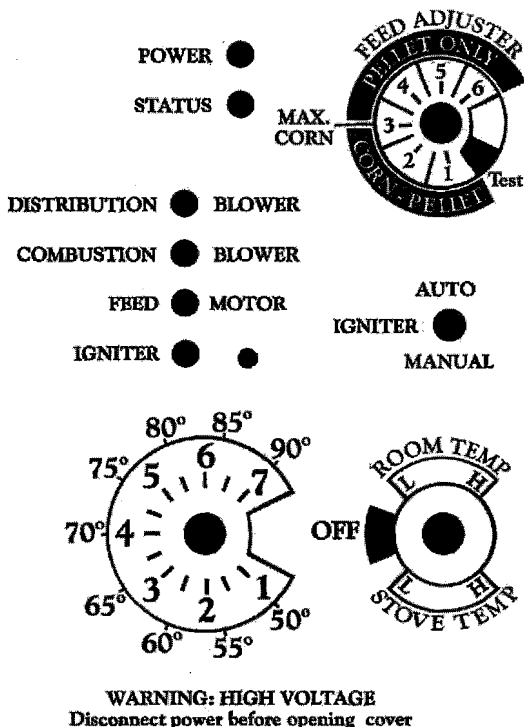

Fig. 23: This setting will produce a large viewing fire without a distribution blower operating.

# MANUAL START UP

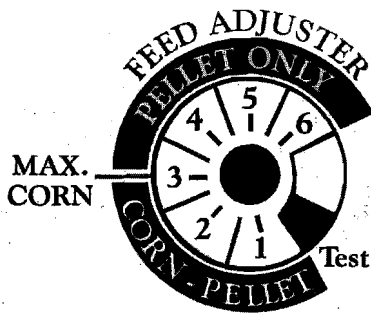

Fig. 24

## Corn Burnpot

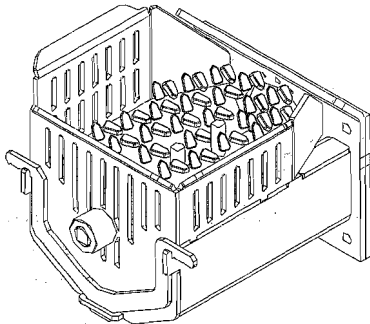

Fig. 25

## Optional Pellet Burnpot

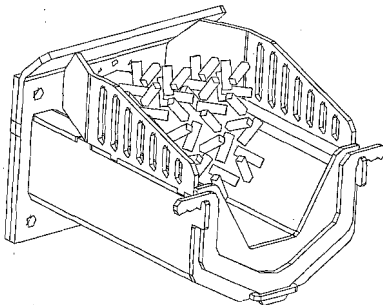

Fig. 26

## Warning

"NEVER USE GASOLINE, GASOLINE-TYPE LANTERN FUEL, KEROSENE, CHARCOAL LIGHTER FLUID, OR SIMILAR LIQUIDS TO START OR "FRESHEN UP" A FIRE IN THIS HEATER. KEEP ALL SUCH LIQUIDS WELL AWAY FROM THE HEATER WHILE IN USE".

## Starting the Fire

**Igniter Switch to "MANUAL"** (down position)

Make sure the unit is plugged into a 120 VAC, 60 HZ electrical source. The power light should be the only light lit. Anytime there is interruption in power at the receptacle, the combustion blower will run for 1 minute after the power is regained.

### Burning Corn

1. Turn the Feed Adjuster to desired feed rate, approximately #2.
2. Turn the Mode Selector to "OFF" and then to the desired mode. This will reset the control and start the combustion motor.
3. Turn the Temperature Dial to the desired setting.
4. Clean the burnpot and housing, if necessary.
5. Fill the burnpot with corn up to the auger shaft. Then place pellets on top of the corn as high as the shelf area. See corn burnpot shown on left.
6. Add starting gel on top of the pellets, stir gel into the pellets and corn for faster lighting.
7. Light the starting gel with a match and close the door. Operation will begin when the fire reaches the proper temperature.
8. Fill the hopper with corn and remove the ashes as required.

### Burning Pellets

**Optional pellet burnpot required to burn pellet fuel.**

1. Turn the Feed Adjuster to the desired feed rate, approximately #4.
2. Turn the Mode Selector to "OFF" and then to the desired mode. This will reset the control and start the combustion motor.
3. Turn the Temperature Dial to the desired setting.
4. Clean the burnpot and housing, if necessary.
5. Fill the burnpot with pellets so that the auger tube opening is covered and slopes away from the auger tube opening. See pellet burnpot shown on left.
6. Add the starting gel on top of the pellets. Stir the gel into the pellets for fast lighting.
7. Light the starting gel with a match and close the door. Operation will begin when the fire reaches the proper temperature.
8. Fill the hopper with pellets and remove the ashes as required.

## Shut-Down Procedure

To kill the fire or stop burning the stove, turn the Mode Selector to "OFF". This will cause the fire to diminish and burn out. When the fire burns out and the stove cools down everything will stop. **NOTE: The combustion blower motor will run for 5 hours after the stove is completely cool.** This insures that all fuel in the burnpot and ashes located in the ash pan are completely cold before shut down of the combustion motor.

If you pull the plug to shut down the stove, all motors will stop. This may cause incomplete combustion and smoke in the firebox. If the load door is opened the smoke may escape.

The best way to shut down the stove is simply let it run out of fuel, then the stove will shut down automatically.

# AUTOMATIC IGNITION ESP CONTROL

## Power Light

Indicates power to the control.

## Status Light

Will be lit in either stove or room temp mode when pointer is not within off position band except after normal shut down. Blinks to indicate errors listed below.

Indicates power to distribution blower.

Indicates power to combustion blower

Indicates power to the feed motor.

Indicates igniter is on.

## Temp dial

Allows you to adjust the room temperature in Room Temp Mode using the outer scale marked in degrees Fahrenheit. It also allows you to adjust the stove temperature while in Stove Temp Mode using the inner scale marked from 1 to 7.

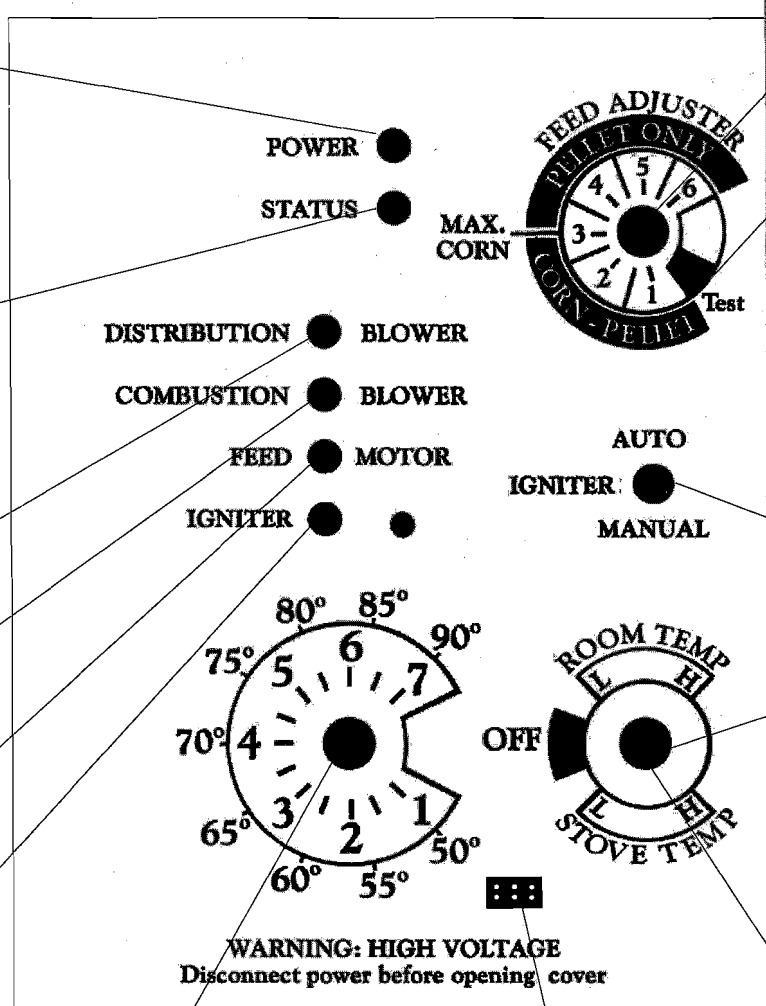

## Feed adjuster

Sets the maximum feed rate

## Test

Runs all motors at full speed for one minute to check operation. After two minutes the stove will go to minimum burn and the blowers will alternate from high to low every minute to remind you that you are still in "Test Mode".

## Igniter switch

Set to appropriate Start-Up mode.

Distribution Blower speed adjustment range.

L = low

H = high

Variable speed anywhere between L and H; although as the stove temp. goes up, so does the L and H scale.

## Mode Selector

Allows you to choose between Room Temp Mode, Stove Temp Mode, or OFF. Also allows you to vary the distribution blower speed by turning the knob to the high or low side of each mode.

## Dealer Diagnostic Port

For dealer maintenance use only. Requires special DDM monitor supplied to Harman Dealers exclusively.

## Status light error message

**1 Blink:** Indicates control board self diagnostic failure. This requires a manual reset\*.

**3 Blinks:** Indicates ESP (Exhaust Sensing Probe) failure. This requires a manual reset\*.

**4 Blinks:** Can occur only in Room Temp Mode and indicates Room Sensing Probe failed or not installed. If a Room Sensing Probe is then installed, the status light will automatically reset.

NOTE: Unit will not start in "AUTO" with this status error.

**5 Blinks (In Igniter Auto. Mode Only):** Indicates that the unit has failed to light within the 45 minute start cycle. To reset - Turn Mode Selector to "OFF", then turn to either mode again.

**6 Blinks :** Indicates that the control has calculated poor or incomplete combustion occurring for more than 50 minutes. See Troubleshooting section for more details.

A six blink status may be set if the stove is allowed to run out of pellets. To reset, turn mode selector to "OFF" then back on to the desired mode. If the unit was not out of pellets, see Troubleshooting section, Page 24, for more details.

\* **Manual reset**- Disconnect power cord for a few seconds and reconnect. If error still occurs call your Harman Dealer.

# Low Draft Voltage Adjustment

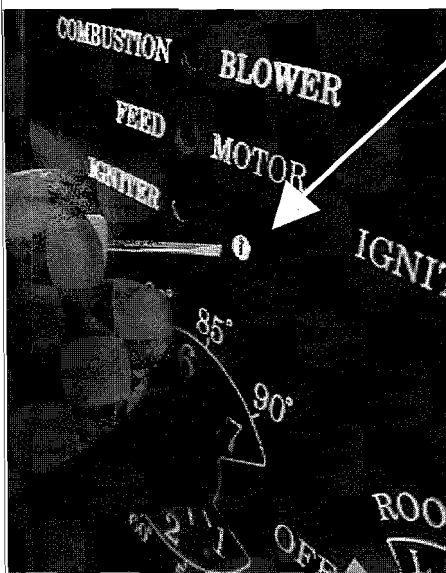
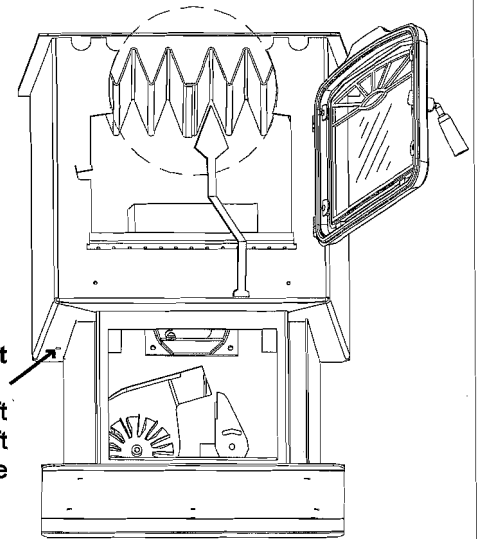

Fig. 27

## **Combustion Motor Speed Control**

**Low draft only set point.**

The small straight screwdriver slot is plastic; therefore, the unit can be adjusted while in operation.



## **Draft Meter bolt hole location**

On a PC 45 the draft hole is under the left rear corner of the firebox.

Fig. 28

## Low Draft Voltage Adjustment

These units are pre-tested at the factory with exactly 120 Volts A.C., 60 Hz. They are checked and adjusted for firebox tightness, gasket leakage, motor operation and igniter operation. The PC 45 is then factory set at a mid-point adjustment and in most cases will not need any adjustments. **NOTE: The factory low draft setting may not be correct for the units permanent installation conditions.**

The control board on the PC45 is equipped with a low draft adjustment port. Located on the control face just to the right of the igniter light. This voltage adjustment is provided to allow the unit to be adjusted for the household voltage where the unit is going to be in permanent operation. **NOTE: The line voltage varies from area to area and often home to home.**

The low draft voltage should be adjusted to achieve the most efficient burn on low burn or "maintenance". This voltage adjustment allows the installer to change the low voltage set point approximately 10 volts. This adjustment should be done by the installer during set up because a draft meter reading is **required** to insure proper set up.

If the unit is not adjusted properly, it does not cause a safety concern. If the unit is adjusted too high, only efficiency is lost. If the unit is adjusted too low, the low draft pressure switch will not allow the feeder motor or the igniter to operate.

A simple draft test should be performed after completing the flue pipe installation. To record the results for future reference:

1. Plug unit into a 120VAC, 60 HZ outlet.
  2. Close the hopper lid, front view door, and the ash pan access door. Neither fuel or a fire are required for this test.
  3. With the mode selector in the "OFF" position, turn the feed adjuster to "TEST".
  4. Record the high draft \_\_\_\_\_ in W.C. (Normal is -.35 to -.55) The control will be on the High Draft for a total of 2 minutes.
  5. After 2 minutes is up, the combustion motor will go down to low draft and the distribution blower will go on high. Allow approximately 15 seconds to pass for the combustion motor to slow before checking the low draft.
  6. If the low draft is between -.25 and -.35, record the reading \_\_\_\_\_ in W.C. If the reading is higher, slowly turn the set screw counter-clockwise until the draft lowers. If the reading is lower, very slowly turn the set screw clockwise until the draft increases.
- NOTE: The test mode alternates from high to low draft every 60 seconds. If more time is needed for draft adjustment, wait until the next low draft cycle.**
- NOTE: In some cases, the draft may not go as low as -.25 to -.35 even with the set screw completely counter-clockwise. This is not a problem.**

# Maintenance

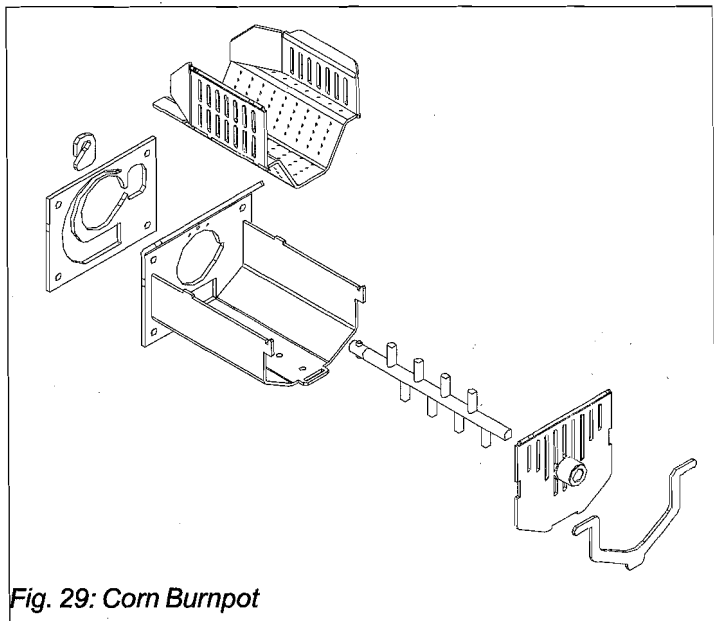

Fig. 29: Corn Burnpot

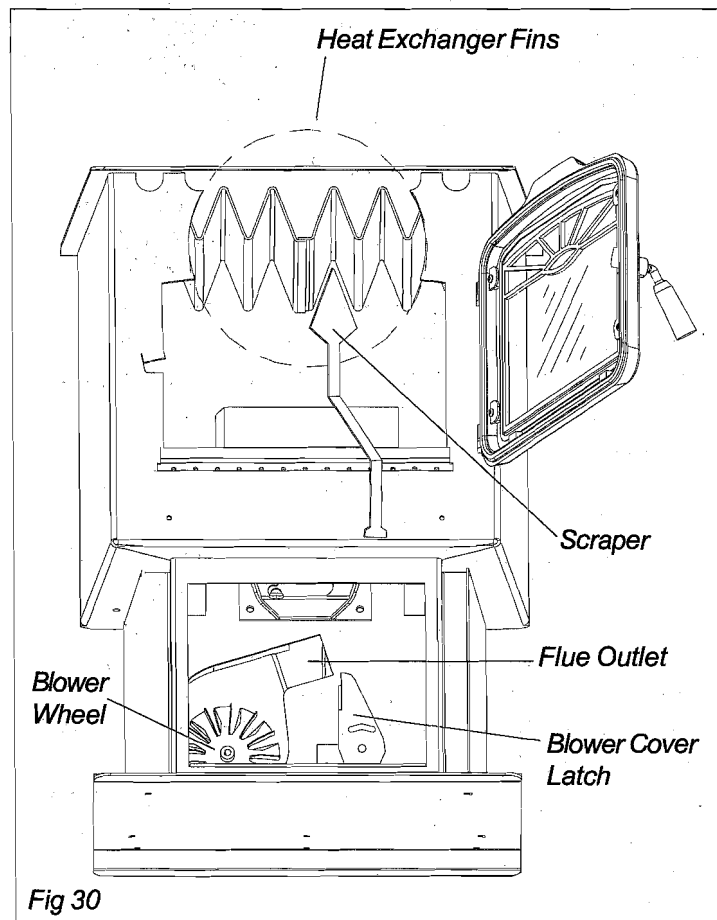

Fig 30

## Removing Ashes:

The frequency in which you will need to empty the ash pan will vary depending on the conditions that the stove has been operating in. For example: A stove burning on high continuously will probably need the ashes removed every 1 to 2 days, whereas a stove burning on low or cycling off periodically may be able to go 3 to 8 days or longer.

**Ashes should be placed in a metal container with a tight fitting lid. The closed container of ashes should be placed on a noncombustible floor or on the ground, well away from all combustible materials, pending final disposal. If ashes are disposed of by burial in soil or otherwise locally dispersed, they should be retained in the closed container until all cinders have thoroughly cooled.**

It is recommended that the stove is cold and shut down when removing ash pan.

1. Pull up on the latch handle to swing the ash pan access door out and to the right.
2. Use the ash pan handle to carry and dispose of ashes.
3. Slide the ash pan back into the stove.

## Cleaning:

If you have been burning corn, the stove will need to be cleaned approximately once a month. The amount of corn burned and the frequency of these cleanings will vary depending on the quality of the corn used.

If you have been burning pellets, the stove will need to be cleaned approximately every 2 to 3 months. The amount of pellets burned and the frequency of these cleanings will vary depending on the quality of the pellets used.

1. Shut down stove and **disconnect power cord** to insure that all motors are stopped.
2. Clean the heat exchanger with the scraper as shown in Fig. 30.
3. Brush or scrape the inside walls of the stove to remove fly ash.
4. Remove the burn pot for cleaning by:
  - Lift up and remove the front plate lock & front plate.
  - Remove the auger extension (corn burnpot only).
  - Remove the burnpot grate.
  - Clean all fines and debris.
  - Reinstall in reverse order.

**NOTE:** See burnpot maintenance section for a more detailed description on burnpot maintenance and cleaning.



# Maintenance

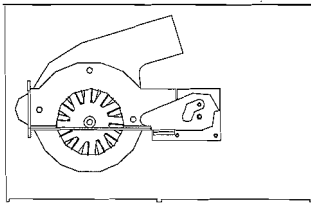

Fig. 31: Latch "closed" with blower cover in place. Burn pot clean-out is closed.

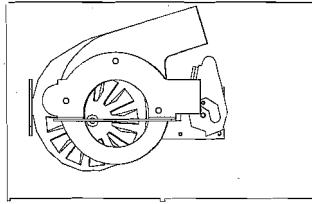

Fig. 32

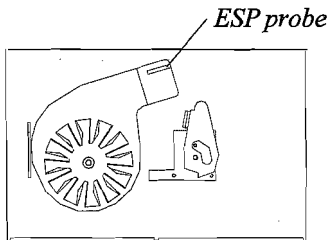

Fig. 33: Exposed blower wheel and flue opening, NOTE: ESP probe is visible.

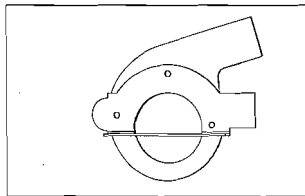
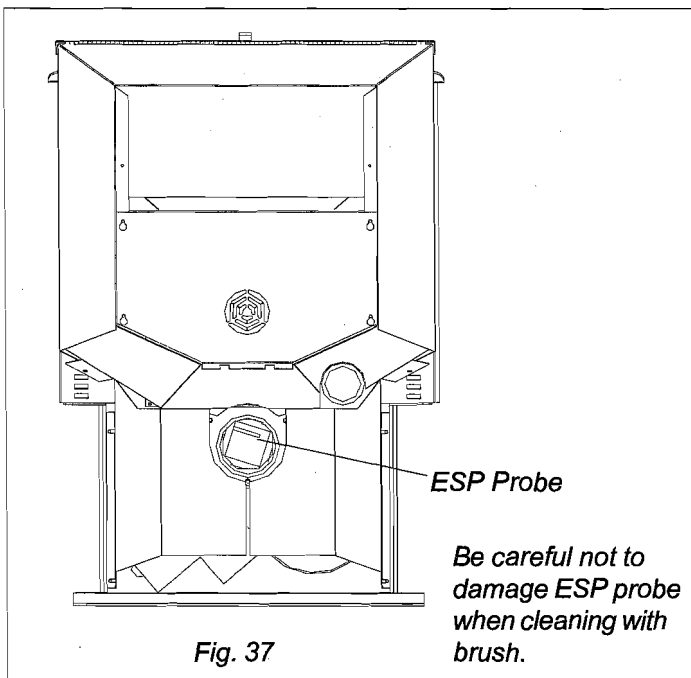
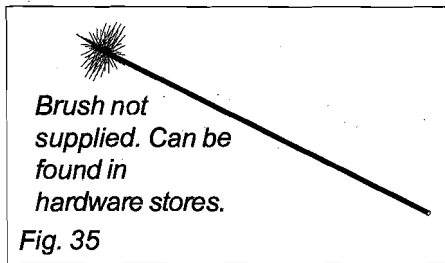

Fig. 34: Blower cover removed.



(Cleaning continued)

5. Remove the ash pan.
6. Remove the combustion blower cover by turning the blower cover latch vertical as shown in fig. 30. Slide the cover out of the slot on the left. This will expose the combustion blower wheel and flue outlet, fig. 33.
7. Clean the blower wheel with a brush and a vacuum cleaner.
8. Use a brush to clean the flue, being careful not to damage the ESP probe. The flue goes straight through into the vent pipe therefore, the vent pipe can also be cleaned to some extent through the flue outlet.
9. Reinstall the blower cover and relatch.
10. Slide ash pan into the stove and latch into place.

## Cleaning of Feeder Fines Area

1. Remove the rear shields to access the feeder cover.
2. Remove the wing nut on the feeder cover and slide the cover off the threaded rod.
3. Remove all fines with a vacuum.

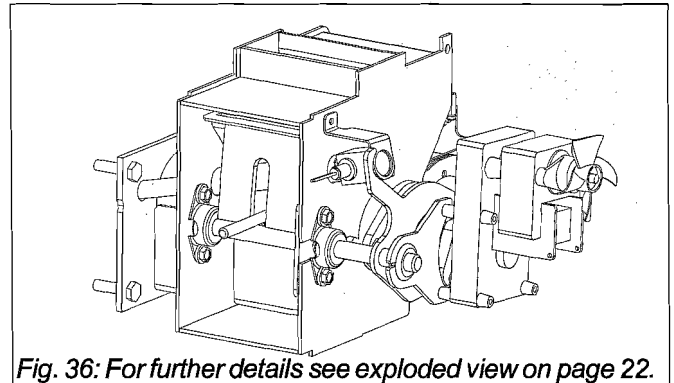

## Soot and Fly Ash

The products of combustion will contain small particles of fly ash. The fly ash will collect in the exhaust venting system and restrict the flow of the flue gases. Incomplete combustion, such as occurs during startup, shutdown, or incorrect operation of the room heater, will lead to some soot formation which will collect in the exhaust venting system. The exhaust venting system should be inspected after the first month of burning to determine the frequency of cleaning that will be required. NOTE: The frequency could vary from once a month to once a season depending on the quality of the fuel being used.

# Maintenance - Burn Pot

## Burn Pot Cleaning and Maintenance

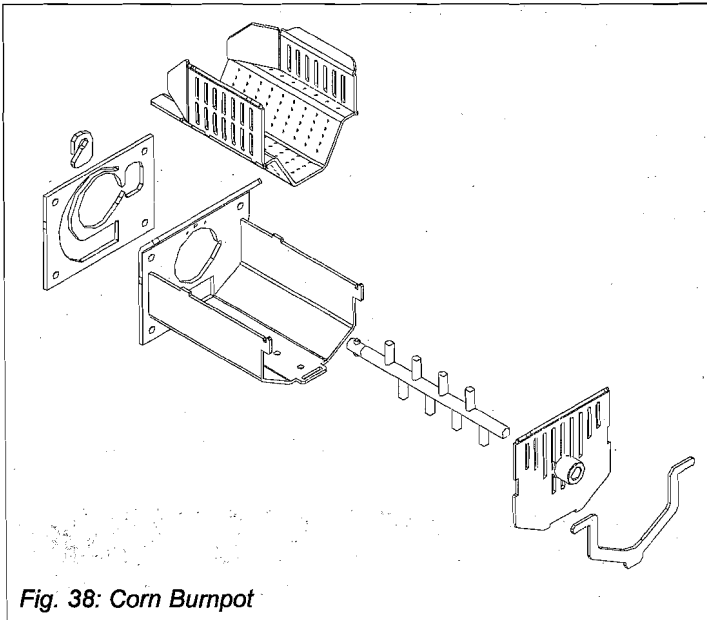

Fig. 38: Corn Burnpot

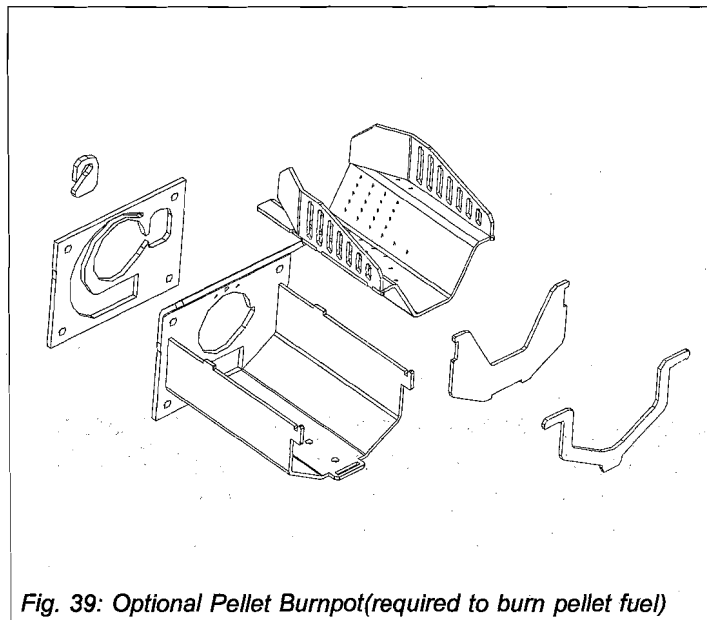

Fig. 39: Optional Pellet Burnpot(required to burn pellet fuel)

1. Be sure the stove power is turned off.
2. Lift up and remove the front plate lock and front plate. Set aside the front plate.
3. Remove the auger extension by pulling toward you, then set aside (corn burnpot only)
4. Remove burnpot grate and set aside.
5. Clean all fines and debris that has accumulated.
6. Install the spare "clean" burnpot grate making sure the 2 holes line up with the 2 tabs in the burnpot housing.
7. Now install the spare "clean" auger extension into the auger shaft. Make sure there isn't any corn or debris in the shaft opening. This will prevent the auger extension from being fully inserted into the shaft.
8. Align the auger extension through the hole in the spare "clean" front plate and place front plate against the burnpot grate and housing.
9. Install the front plate lock.
10. The "dirty" auger extension, burnpot grate and front plate just removed can now be cleaned for the next scheduled maintenance. NOTE: After cleaning of these parts, inspect for excessive wear and replace as needed.

## Cleaning of Burnpot Parts

Cleaning can be performed in 2 basic ways:

1. Because the slag buildup will absorb moisture from the air when cool, the parts can just be left exposed for several days and the slag buildup will crumble off of the parts.
2. To accelerate this process, the parts can be soaked in water for approximately 30 minutes (depending on the amount of buildup, they could be cleaned in less time).

NOTE: Cleaning of these parts is not necessary until you see that there is noticeable decrease in the quality of the flame in the burnpot. Example: Unburned fuel being pushed over the burnpot.

# PC 45 Trouble-Shooting

## FEEDER DOES NOT FEED

1. No fuel in hopper.
2. Firebox draft may be too low for low draft pressure switch in feeder circuit to operate. **Check for closed doors**, loose or missing gasket on doors or hopper lid, faulty pressure switch.
3. Feed motor will not run until ESP senses 200° F. Maybe you did not put enough pellets in the burn pot before lighting the fire.
4. Something is restricting flow in the hopper or causing the slide plate to stick.
5. Feed motor has failed.

## PARTIALLY BURNED FUEL

1. Feed rate too high.
2. Draft too low.
3. Burn pot may need to be cleaned.
4. Combination of all the above.
5. #6 status blink: A 6 blink control board status indication is caused by poor or incomplete combustion. The circuit board has the ability to track the combustion through feed settings and ESP temperatures. When the control board has calculated poor or incomplete combustion it will shut down the unit as a safety feature. (Poor or incomplete combustion is a contributor of creosote which may cause a chimney fire)

A 6 blink status may be caused by several things:

1. Blocked or partially blocked flue.
2. Blocked or partially blocked inlet air.
  - a. backdraft damper on the inlet pipe may be stuck closed.
  - b. if outside air is installed the inlet cover may be blocked.
3. The air chamber under the burnpot may be filled with fines and small bits of ash.
4. The holes in the burnpot may be getting filled with ash or carbon buildup.
5. Combustion blower fan blades may need cleaned.
6. There is no fuel in the hopper.

## COMBUSTION BLOWER RUNS AFTER SHUT DOWN

This is a normal function. The combustion blower will run for 5 hours after the stove is completely cool.

## SMOKE SMELL

Seal the vent pipe joints and connection to stove with silicone.

## FIRE HAS GONE OUT

1. No fuel in hopper.
2. Draft setting is too low.
3. Something is restricting fuel flow.
4. Feed motor or draft motor has failed.
5. Power failure or blown fuse.

## SMOKE IS VISIBLE COMING OUT OF VENT

1. Air-fuel ratio is too rich.
  - A. Feed rate too high.
  - B. Draft too low caused by a gasket leak.
2. Unit is in an ignition cycle.

## LOW HEAT OUTPUT

1. Feed rate too low
2. Temperature setting too low (Stove Temp Mode)
3. Draft too low because of gasket leak.
4. Poor quality or high moisture fuel.

## Helpful Hints

### Cleaning Burn Pot

Whenever your stove is not burning, take the opportunity to scrape the burn pot to remove carbon buildup. A vacuum cleaner is handy to remove the residue. Be sure the stove is cold if you use a vacuum.

Carbon buildup can be scraped loose with the fire burning using the special tool provided with your stove. Scrape the sides of the burnpot (corn grate), and the floor and sides (pellet grate). The carbon will be pushed out by the incoming fuel. Always wear gloves to do this.

### Removing Ashes

Turn the Temp Dial to number 1 approximately 30 minutes before removing ashes. This will result in a cooler stove and ash pan.

Maximum Feed Adjuster settings are not needed in most cases. Operating in the normal range (#2 corn) (#4 pellet) is recommended when maximum heat output is not required. The ESP probe prevents the stove from being over-fired.

Keep the stove free of dust and dirt.

## Fuel

The PC 45 can burn corn with moisture levels up to 16%, with 14.5% or less ideal.

Pellet fuels are put into 3 categories in terms of ash content. Premium at 1% or less, Standard at 3% or less and all others at 3% or more.

The PC 45 is capable of burning all 3 categories of pellets due to a patented feeder and burn pot system.

It should be noted, however, that higher ash content will require more frequent ash removal and may provide less BTU's per pound. Normally, standard and high ash pellets cost less than premium pellets and can be cost effective when burned in the PC 45.

The moisture content of pellets must not exceed 8%. Higher moisture will rob BTU's and may not burn properly.

# Feeder and Specifications

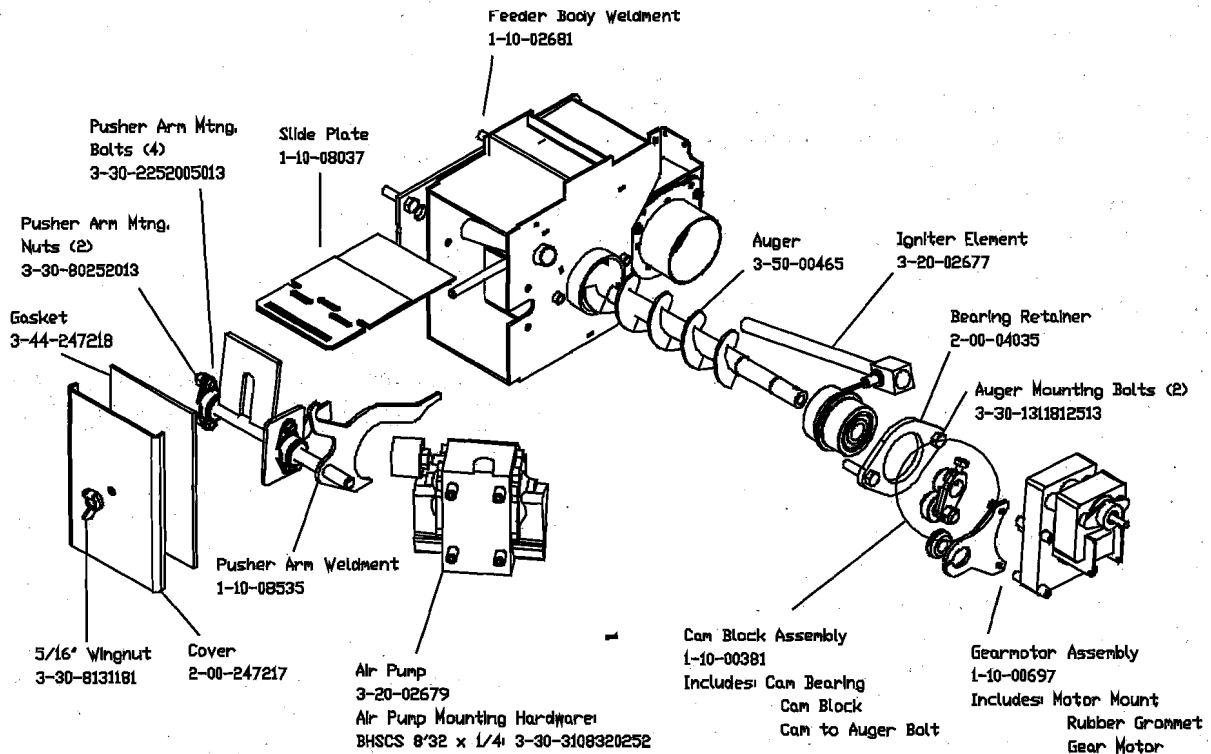
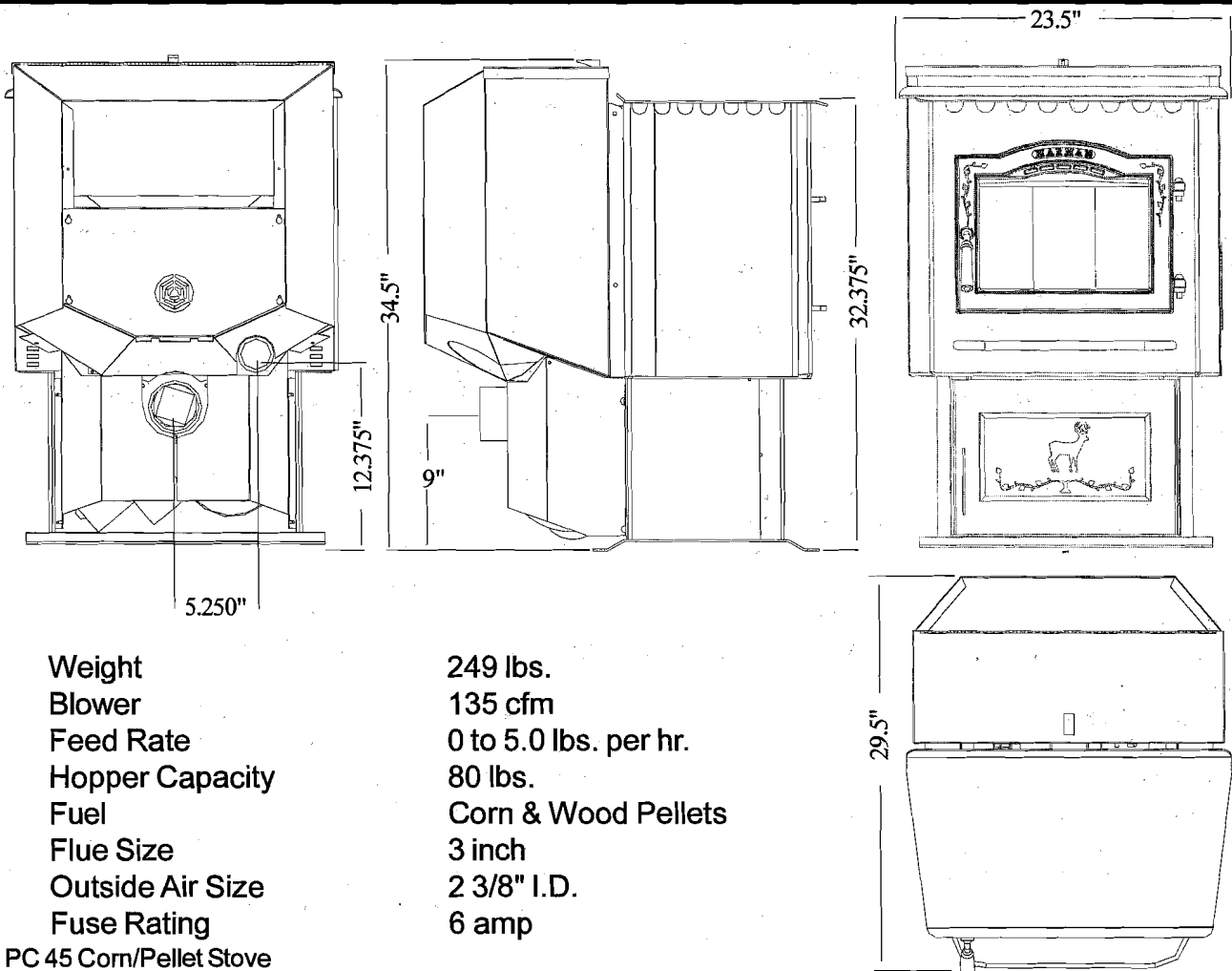

Fig. 40

## Specifications



## Door Options

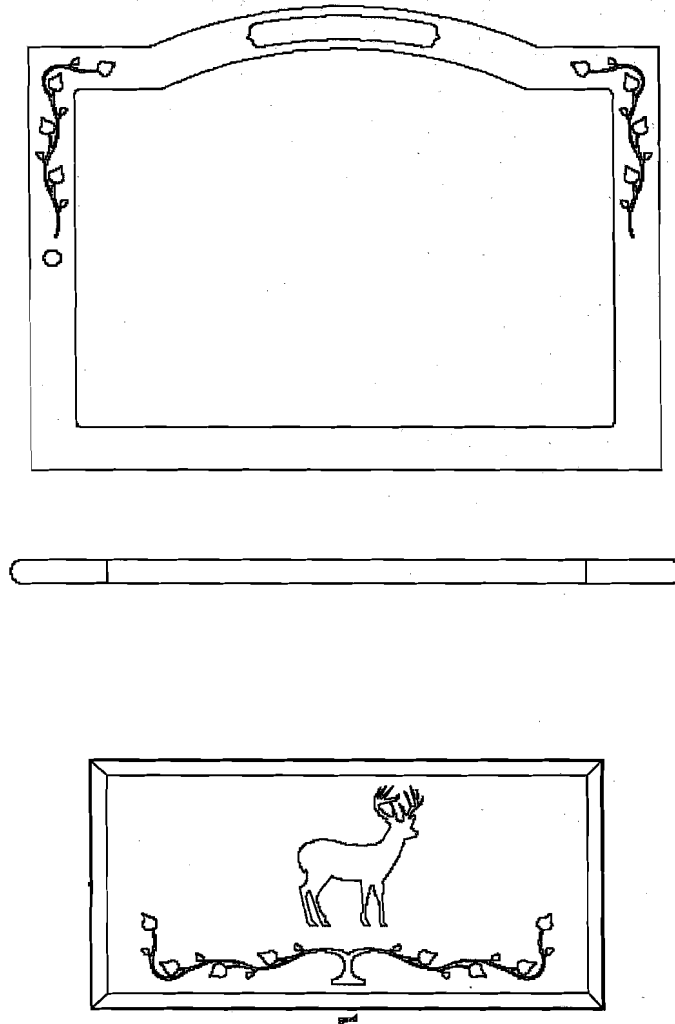

Fig. 41

### Optional Trim

To install, lay the frame face down on a soft surface. Fasten door frame by inserting the 4 threaded posts on the frame through the door. The posts should line up with the 4 holes located at the corners of the door. Once the posts are through the door, fasten frame with 4 nuts and tighten until the frame is snug.

To install ash lip trim, simply slide the trim over the ash lip and into the groove on the trim.

### Decorative Tile

Decorative tile is available in several configurations. The tile installs behind the trim on the ash door.

### Cleaning Plated Trim

Gold or nickel plated hardware should never be buffed or polished. Abrasive cleansers and metal polishes will remove the plating and therefore should never be used. If the plating needs to be cleaned, wait until the stove is completely cool, then use a sponge, soap and water to gently remove dirt and stains. Before relighting the stove, remove all soap residue and wipe dry.



# OPTIONS

## Room Sensor Installation

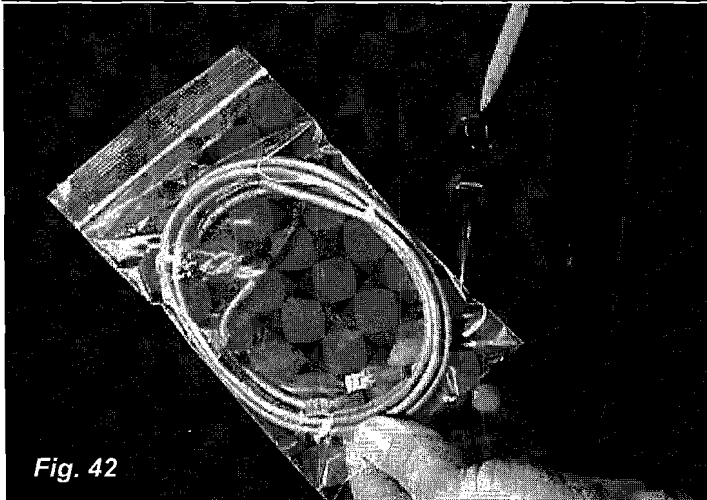

Fig. 42

The room sensor is a small temperature sensor on the end of a 60" gray wire. This sensor is installed much like a standard wall thermostat. Because it is so small, it can be hidden along the trim of a doorway or even up the leg of a coffee table. There is a remote room sensor port on the rear of the unit for easy external connection. Use standard 18-2 thermostat wire to extend the distance to the desired location (100' maximum). The room sensor should be installed in the location where you want to control the temperature.

NOTE: Distances of more than 25 feet from the unit or in another room are not recommended.

**It is recommended that the room sensor be installed, even if only installed on the rear of the unit as a return air sensor.** There is an intake screen on the bottom of the rear sheetmetal enclosure. This is an ideal place to trap the sensor head to sense return air temperature.

## Side Heat Shields

Side heat shields are available to reduce the clearance to combustible materials. See Fig. 43.

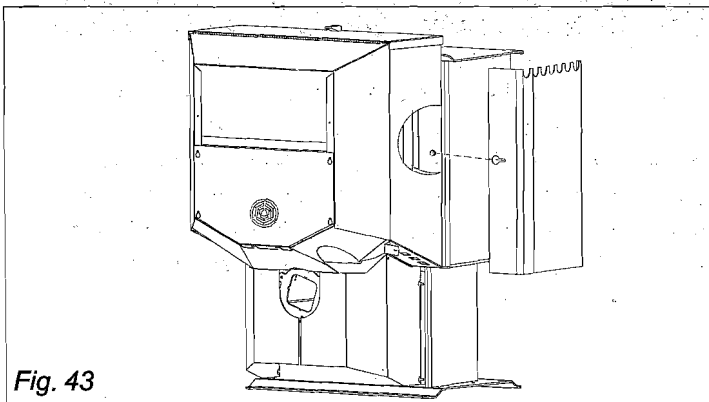

Fig. 43

## Hopper Extension

The hopper extension allows you to put more pellet fuel in the hopper and extends burn time on one load of corn. The hopper extension adds 65 pounds to the existing 80 pound hopper capacity, allowing you to load 145 pounds of corn at one time. See Fig. 44.

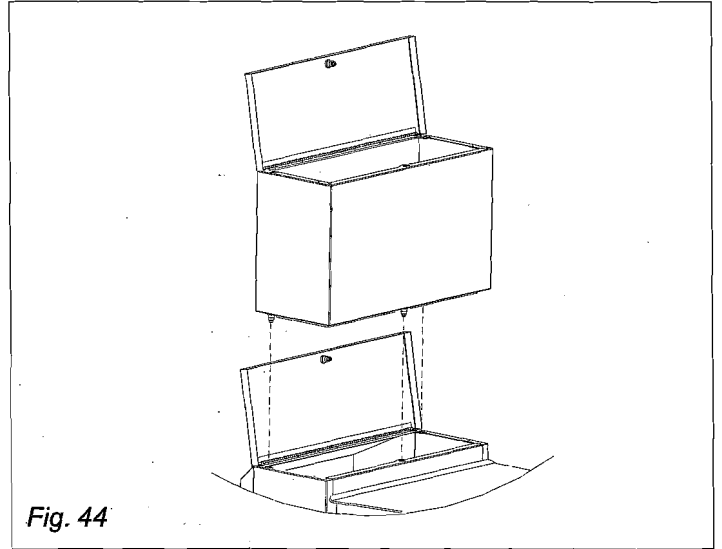

Fig. 44

## Optional Pellet Burnpot Grate

The pellet burnpot grate is required to burn pellet fuel.

The corn burnpot and pellet burnpot grates were designed to be interchangeable, and are easily installed and removed without the use of tools.

Each PC 45 comes with (2) corn burnpot grates to aid in continual burning of corn in the event that the corn burnpot needs to be cleaned. Please note **they are both corn burnpot grates, not one corn grate and one pellet grate.**

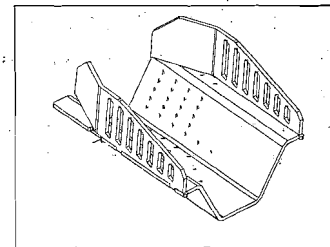
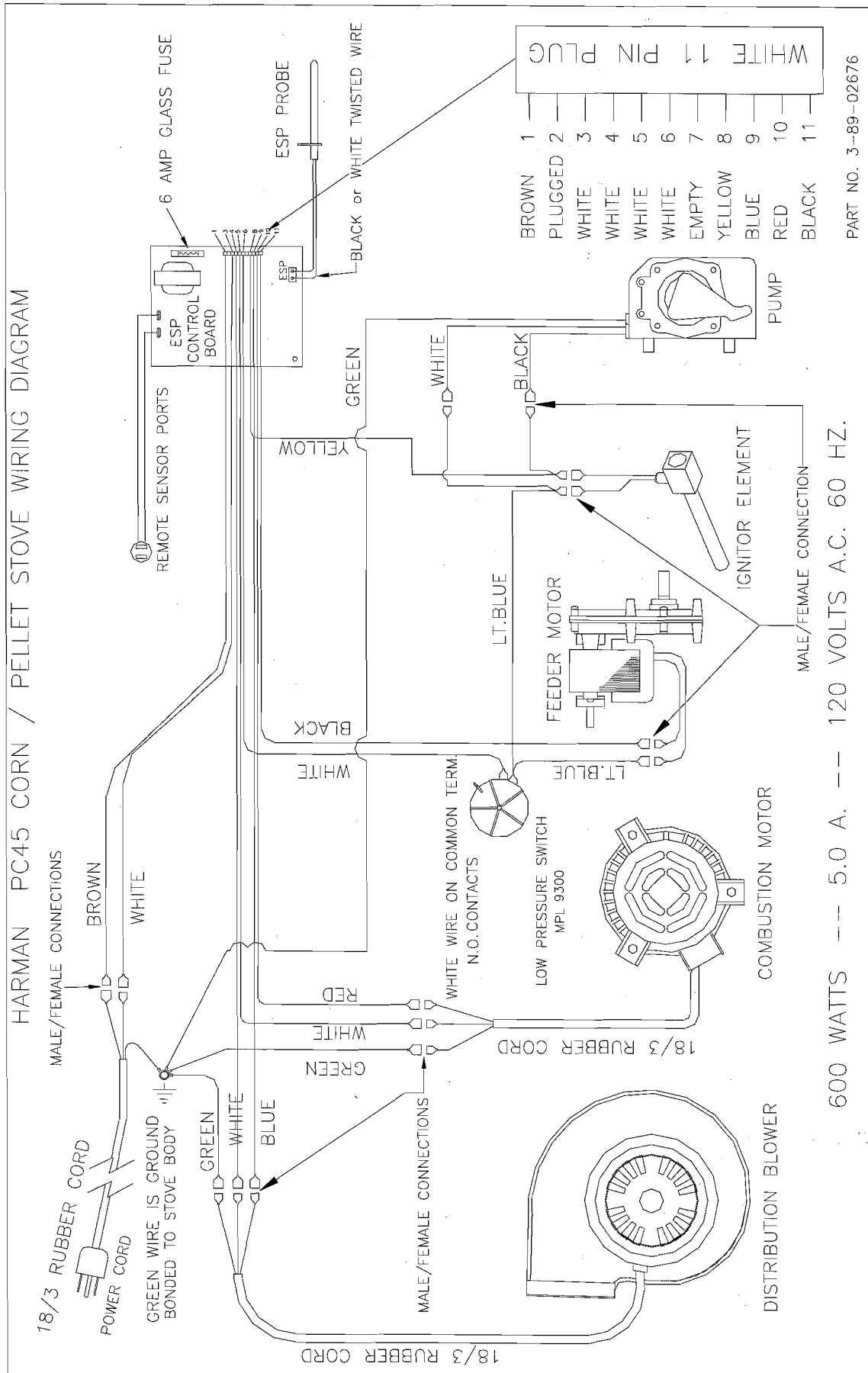

Fig. 45: Optional Pellet Burnpot Grate

## Optional Hopper Screen (Corn Strainer)

The hopper screen/corn strainer was designed to sift the corn before it is fed into the burn pot. This sifting will catch unwanted materials from being burned.

# PC 45 Wiring Diagram



## PC 45 Parts List

<u>Description</u>	<u>Part Number</u>
Hopper Gasket(6 ft.)	0-88-00248
Ash Pan Assembly	1-10-05800
Burnpot Housing Weldment	1-10-724103
Burnpot Grate Weldment (corn)	1-10-724108
Burnpot Front Plate Weldment (corn)	1-10-724107
Burnpot Front Plate Lock	2-00-724105
Grain Cap	2-00-724205
Corn Auger Extension	3-00-02676
Ceramic Insert Plate	2-00-724104
Ceramic Insert	3-20-05238
Wiring:	
Main Harness	3-20-02680
Neutral Harness	3-20-02681
Air Pump Ground Wire	3-20-02682
Combustion Blower Ground Wire	3-20-02683
Distribution Blower Ground Wire	3-20-00496
Right Rear Shield	2-00-06468-1
Left Rear Shield	2-00-06468-2
Arrow Scraper	2-00-773850
Thermister Probe	3-20-00744
Room Sensor	3-20-00906
Circuit Board G5236	3-20-05375
Differential Switch	3-20-9301
5" Single Fan Blade	3-20-40985
Combustion Blower	3-21-08639
Distribution Blower	3-21-22647
Hopper Lid Latch	3-31-199110
3/16" Rubber Washer (for Hopper Lid)	3-31-90131101
Power Cord	3-20-29685
Fire Brick (3)	3-40-900450125
White/Black Control Knob(3)	3-31-00605
Control Knob Shaft(3)	3-31-00015
Front Glass	3-40-950133125
Gaskets:	
Feeder Gasket	3-44-00409
Ceramic Insert Plate Gasket	3-44-724114
Burnpot Gasket	3-44-724115
Tailpipe Gasket	3-44-06179
Owners Manual	3-90-02686
Igniter Element	3-20-02677
Air Pump	3-20-02679
<b><u>Options:</u></b> Hopper Extension Assembly	1-00-08636
PC 45 Corn Strainer (hopper screen)	1-00-724300
Outside Air Assembly	1-10-08542
3' Flex Pipe	2-00-08543
Pellet Grate Kit	1-00-724112
(includes pellet burnpot grate weldment and front plate)	
Trim Kit	1-00-06717
Tile Pack(1 piece)	3-43-120601(10 choices)

**HARMAN GOLD WARRANTY (for corn stove)**  
**6 YEAR TRANSFERABLE LIMITED**  
**WARRANTY (Residential)**  
**1 YEAR LIMITED WARRANTY (Commercial)**



Harman Stove Company warrants its products to be free from defects in material or workmanship, in normal use and service, for a period of 6 years from the date of sales invoice and for mechanical and electrical failures, in normal use and service, for a period of 3 years from the date of sales invoice.

If defective in material or workmanship, during the warranty period, Harman Stove Company will, at its option, repair or replace the product as described below.

The warranty above constitutes the entire warranty with respect to Harman Stove Company products. HARMAN STOVE COMPANY MAKES NO OTHER WARRANTY, EXPRESSED OR IMPLIED, INCLUDING "ANY" WARRANTY OF MERCHANTABILITY, OR WARRANTY OF FITNESS FOR A PARTICULAR PURPOSE. No employee, agent, dealer, or other person is authorized to give any warranty on behalf of Harman Stove Company. This warranty does not apply if the product has been altered in any way after leaving the factory. Harman Stove Company and its agents assume no liability for "resultant damages of any kind" arising from the use of its products. In addition, the manufacturer and its warranty administrator shall be held free and harmless from liability from damage to property related to the operation, proper or improper, of the equipment.

THERE ARE NO WARRANTIES WHICH EXTEND BEYOND THE DESCRIPTION ON THE FACE HEREOF.

THESE WARRANTIES APPLY only if the device is installed and operated as recommended in the user's manual.

THESE WARRANTIES WILL NOT APPLY if abuse, accident, improper installation, negligence, or use beyond rated capacity causes damage.

HOW TO MAKE A CLAIM - Any claim under this warranty should be made to the dealer from whom this appliance was purchased. Then contact is made with manufacturer, giving the model and serial numbers, the date of purchase, your dealer's name and address, plus a simple explanation of the nature of the defect. Extra costs such as mileage and overtime are not covered. Nuisance calls are not covered by these warranties.

THIS WARRANTY IS LIMITED TO DEFECTIVE PARTS - REPAIR AND/OR REPLACEMENT AT HARMAN STOVE COMPANY'S OPTION AND EXCLUDES ANY INCIDENTAL AND CONSEQUENTIAL DAMAGES CONNECTED THEREWITH.

WARRANTY EXCLUSIONS: Failure due, but not limited to, fire, lightning, acts of God, power failures and/or surges, rust, corrosion and venting problems are not covered. Damage and/or repairs including but not limited to; remote controls, filters, fuses, knobs, glass, ceramic brick panels, ceramic fiber afterburners, door packing, tile, ceramic log sets, paint, batteries or battery back-up and related duct work are not covered. Also excluded from this warranty are consumable or normal wear items including but not limited to; flame guides, grates, coal bars, afterburner hoods, fire brick, gaskets. Additional exclusions for corn stoves are burnpot housing weldment, burnpot grate weldment (pellet or corn), burnpot front plate (pellet or corn), burnpot front plate lock, corn auger extension, ceramic insert, and ceramic insert plate. Additional or unusual utility bills incurred due to any malfunction or defect in equipment and the labor cost of gaining access to or removal of a unit that requires special tools or equipment are not covered. Maintenance needed to keep the stove in "good operating condition" is not covered. This includes, but is not limited to, cleaning, adjustment of customer controls and customer education. Labor, materials, expenses and/or equipment needed to comply with law and/or regulations set forth by any governmental agencies are not covered.

This Warranty provides specific legal rights and the consumer may have other rights that vary from state to state.

In the event of change in ownership, the remaining portion of this warranty may be transferred to the new owner by sending the new owner information and a transfer fee of \$25.00 US to the Harman Stove Company.

PLEASE READ THE LITERATURE BY THE MANUFACTURER FOR THE VARIOUS ACCESSORY DEVICES. THE MANUFACTURER WARRANTS THESE ACCESSORY DEVICES, NOT HARMAN STOVE COMPANY OR THEIR WARRANTY ADMINISTRATOR. FURTHERMORE, THESE ACCESSORY DEVICES MUST BE INSTALLED AND USED ACCORDING TO THE RECOMMENDATIONS OF THE MANUFACTURER.

REMEDIES - The remedies set forth herein are exclusive and the liability of seller with respect to any contract or sale or anything done in connection therewith, whether in Contract, in tort, under any warranty, or otherwise, shall not, except as herein expressly provided, exceed the price of the equipment or part of which such liability is based.

CLARIFY - The above represents the complete warranty, which is given in connection with stoves, manufactured by Harman Stove Company. No other commitments, verbal or otherwise, shall apply except by a written addendum to this warranty.



MIP-2113