

Installation & Operating Manual

P61-2 Pellet Stove Owners Manual

HARMAN[™]
HOME HEATING

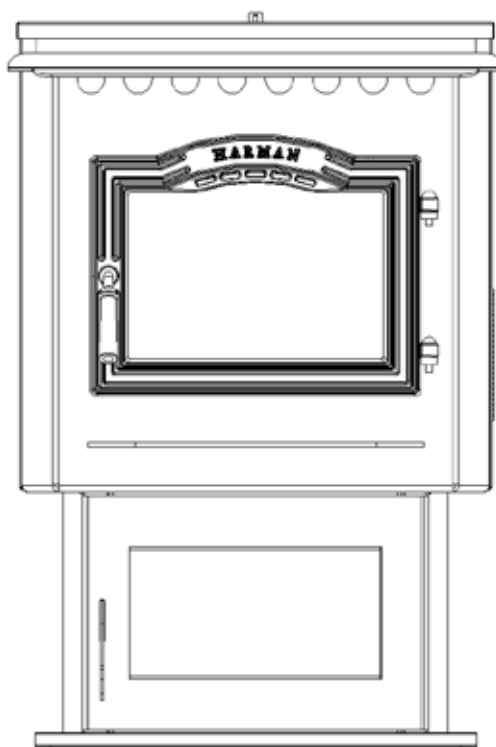

We suggest that our hearth products be installed and serviced by professionals who are certified in the U.S. by the National Fireplace Institute (NFI) as NFI Specialists.

“Ce manuel est disponible en Français sur demande”



SAFETY NOTICE

PLEASE READ THIS ENTIRE MANUAL BEFORE YOU INSTALL AND USE YOUR NEW ROOM HEATER. FAILURE TO FOLLOW INSTRUCTIONS MAY RESULT IN PROPERTY DAMAGE, BODILY INJURY, OR EVEN DEATH.

FOR USE IN THE U.S. AND CANADA. SUITABLE FOR INSTALLATION IN MOBILE HOMES

IF THIS HARMAN STOVE IS NOT PROPERLY INSTALLED, A HOUSE FIRE MAY RESULT. FOR YOUR SAFETY, FOLLOW INSTALLATION DIRECTIONS.

CONTACT LOCAL BUILDING OR FIRE OFFICIALS ABOUT RESTRICTIONS AND INSTALLATION INSPECTION REQUIREMENTS IN YOUR AREA.

CONTACT YOUR LOCAL AUTHORITY (SUCH AS MUNICIPAL BUILDING DEPARTMENT, FIRE DEPARTMENT, FIRE PREVENTION BUREAU, ETC.) TO DETERMINE THE NEED FOR A PERMIT.

CETTE GUIDE D'UTILISATION EST DISPONIBLE EN FRANCAIS. CHEZ VOTRE CONCESSIONNAIRE DE HARMAN HOME HEATING.

SAVE THESE INSTRUCTIONS.

Item# 3-90-05810



W/N 04433
 TESTED TO: UL 1462 ASTM E1509
 OREGON 814-23-900

WH-PN 025

TEST DATE: MARCH 1988

MINIMUM CLEARANCES

TO COMBUSTIBLES:

BACKWALL TO STOVE

CEILING TO STOVE TOP

STOVE CORNER TO DIAGONAL WALL

PREVENT HOUSE FIRES, OPERATE WITH VIEWING & ASH DOOR

CLOSED.

UNIT MUST BE PLACED ON A NON-COMBUSTIBLE FLOOR PROTECTOR

EXTENDING 6" TO THE FRONT, 6" TO SIDES AND 1" TO REAR.

EXHAUST TYPE: LISTED TYPE L OR PL VENT INSTALLED TO VENT

MANUFACTURER'S INSTRUCTIONS AND LOCAL BUILDING CODES.

ELECTRICAL RATING: 5 AMPS, 120 VOLTS, 60 HERTZ

FUEL: PELLETIZED OR BIOMASS

INSTALL AND USE ONLY IN ACCORDANCE WITH MANUFACTURER'S

INSTALLATION AND OPERATING INSTRUCTIONS. CONTACT LOCAL

BUILDING OR FIRE OFFICIALS ABOUT RESTRICTIONS & INSTALLATION

INSPECTION IN YOUR AREA.

EPA EXEMPT PER 40 CFR 60.534, METHOD 28A.

APPROVED FOR USE IN MOBILE HOMES.

INPUT RATING: .75 TO 7.5 LBS PER HOUR.

DO NOT CONNECT THIS UNIT TO A CHIMNEY SERVING

ANOTHER APPLIANCE

LISTED PELLET BURNING ROOM HEATER
MODEL: P 61-2

WHI
 DO NOT REMOVE THIS LABEL
 NE PAS ENLEVER CETTE ETIQUETTE

CORNER INSTALLATION^B WITH SIDE SHIELDS

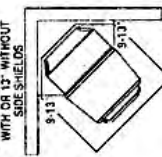

INSTALL WITH MINIMUM CLEARANCES TO WALLS AS SHOWN

SIDEWALL-BACKWALL INSTALLATION WITH SIDE SHIELDS

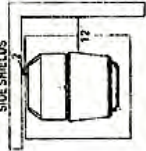

FLOOR PROTECTOR MINIMUM SIZE

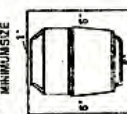

SIDEWALL-BACKWALL INSTALLATION WITHOUT SIDE SHIELDS

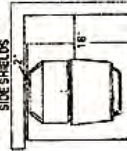

APPAREIL DE CHAUFFAGE CATALOGUE DE
MODELE "P61-2"

ESPACE LIBRE MINIMUM DES MATERIAUX COMBUSTIBLES: 18" DE COTE AU POELE 2" DU MUR ARRIERE AU POELE 20" DU COIN DU POELE AU MUR DIAGONAL 13" PREVENIR LES FEUX DE MAISONS. OPERER SEULEMENT AVEC LA PORTE D'OUVERTURE ET LA PORTE DES CENTRES FERMEES. L'APPAREIL DOIT ETRE PLACE SUR UN PLANCHER PROTECTEUR INCOMBUSTIBLE, CELUI-CI SETENDANT DE 6" EN AVANT, DE 6" DES COTES ET 0"1" DE L'ARRIERE. SORTE D'ECHAPEMENT: VENTILATEUR DE TYPE L OU PL INSTALLE SELON LES INSTRUCTIONS DU FABRICANT ET SELON LES CODES LOCAUX DE LA CONSTRUCTION.

INSTALLATION EN ANGLE^B AVEC PROTECTIONS LATERALES

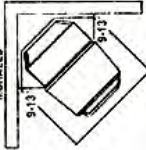

INSTALLER AVEC LES DISTANCES MINIMUM DE SECURITE COMME INDIQUE.

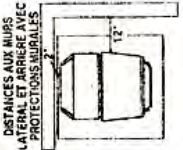

Taille minimale de la protection de sol

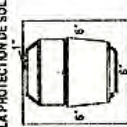

DISTANCES AUX MURS LATERAL ET ARRIERE SANS PROTECTIONS MURALES

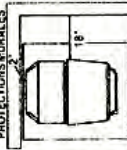

MANUFACTURED BY:
 HARMAN STOVE COMPANY
 352 MOUNTAIN HOUSE ROAD
 HALIFAX, PA 17032
MADE IN USA

NE PAS CONNECTER CET APPAREIL A UNE CHEMINEE SERVANT UN AUTRE APPAREIL.

Fig. 1

Table of Contents

| | |
|------------------------------------|-----------|
| Testing Label | 2 |
| Assembly & Installation | 4 |
| Venting | 7 |
| Operation | 12 |
| ESP Control | 14 |
| Maintenance | 15 |
| Trouble Shooting | 18 |
| Feeder Parts | 19 |
| Specifications | 20 |
| Wiring Diagram | 21 |
| Options | 22 |
| Parts List | 24 |
| Warranty | 25 |

Please read this entire manual before you install and use your new room heater. Failure to follow instructions may result in property damage, bodily injury, or even death.

SUITABLE FOR MOBILE HOME INSTALLATIONS.

SAVE THESE INSTRUCTIONS

Harman Home Heating

352 Mountain House Road
Halifax, PA 17032

Assembly and Installation

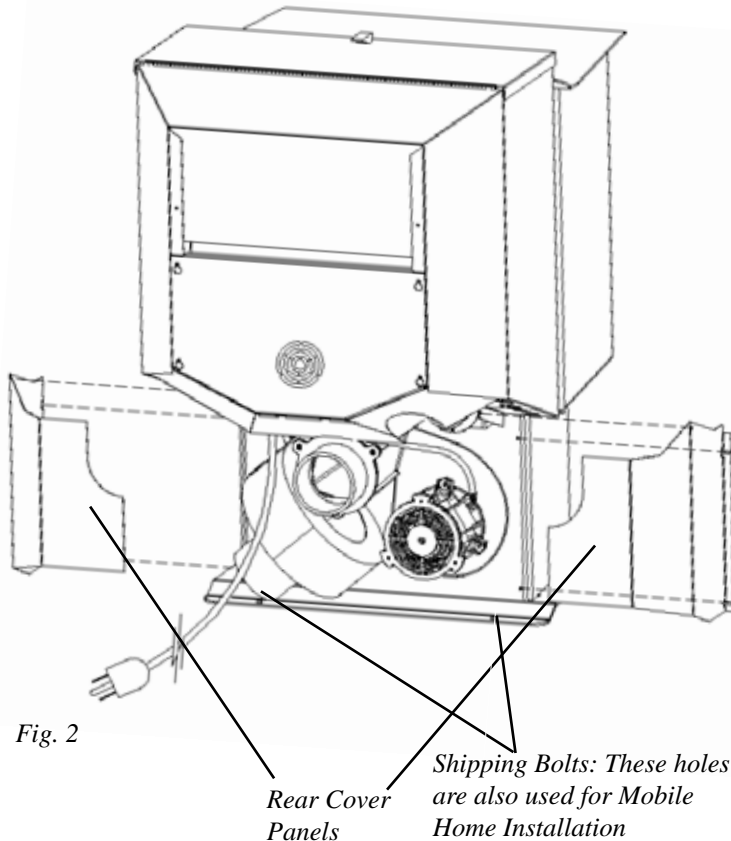

Fig. 2

Unpacking

The P61 is bolted to the skid to prevent movement during shipping.

To free the stove from the skid you must remove the hold-down bolts in the rear of the pedestal base.

Removing or Installing rear cover panels

To remove the rear cover panels, loosen the screws slightly and slide the covers outward as shown in the illustration. To reinstall, simply slide back into place and retighten the screws.

Firebrick

Install the firebrick vertically on the angle above the burnpot.

Flame Guide

Install the cast iron flame guide on top of the burnpot and make sure it is fully seated against the auger opening. The bottom of the flame guide is marked 38+.

Draft Test Procedure

Before attaching any vent pipe to the stove, perform a draft test, for later comparison.

Remove the plug bolt on the underside of the firebox as shown. Using the hole from the bolt, attach a draft meter that is capable of reading at least .5 inches of water column (W.C.). You are going to want the meter reading negative pressure.

Turn the feed adjuster to "Test". For the first minute, everything will run. Record the high draft reading _____. After the first minute, the distribution blower will go to a low speed. Then, after the second minute, two minutes after turning to test, the distribution blower will come back up to high, and the combustion blower will drop to low. During this time, record the low draft _____. Perform the test again after the venting is complete. Compare your readings. If there is more than a .05 difference, you have too much restriction in the venting. There is no adjustment for the draft other than improving the venting configuration. Leaving the stove in "test" will continue to cycle the blowers each minute. Record your final draft readings here. _____ High, and _____ Low.

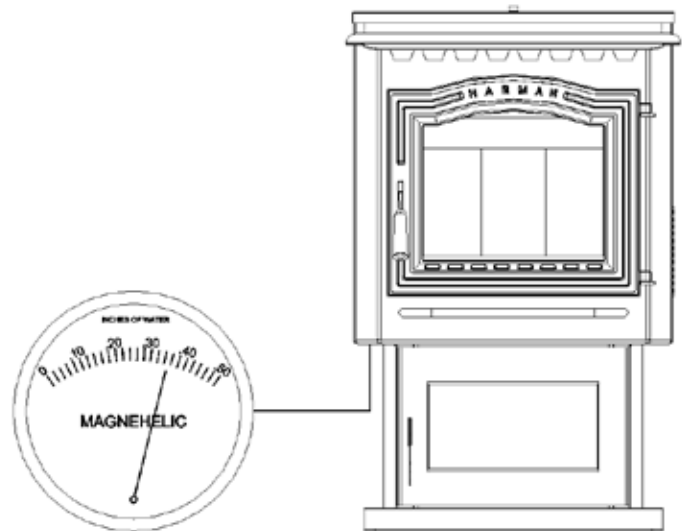

Installation

Installing

Place the stove on a non-combustible floor or UL approved floor protector that extends 6 inches to the front, 6 inches to the sides and 1 inch to the rear of the stove.

Place the stove away from combustible walls at least as far as shown in figures 3,4 and 5. Please note the difference in side wall clearance with and without side shields.

Note that the clearances shown are minimum for safety but do not leave much room for access when cleaning or servicing. Please take this into account when placing the stove.

Connect the power cord to a 120 V.A.C. 60Hz grounded receptacle.

After connecting the flue system, perform the second draft test. However, prior to taking the draft reading be sure all doors and windows in the home are closed. Record the draft reading_____. If this reading is more than .05" lower than the unconnected reading, check for possible restrictions or the need for outside air (see page 7).

Mobile Home Installation

When installing this unit in a mobile home, several requirements must be followed:

1. The unit must be bolted to the floor. This can be done with 1/4" lag screws through the 2 holes in the base plate.

2. The unit must also be connected for the outside air. See page 7.

3. Floor protection and clearances must be followed as shown.

4. Unit must be grounded to the metal frame of the mobile home.

5. The stove may not be installed in a room designated for sleeping.

CAUTION: This appliance must be vented to the outside.

Due to high temperatures, the stove should be placed out of traffic and away from furniture and draperies.

Children and adults should be alerted to the hazards of high surface temperatures and should stay away to avoid burn to skin and/or clothing.

Young children should be carefully supervised when they are in the same room as the stove.

Clothing and other flammable materials should not be placed on or near this unit.

Installation and repair of this Harman Stove should be done by a qualified service person. The appliance should be inspected before use and at least annually by a qualified service person. More frequent cleaning will be required. It is imperative that control compartments, burners, and circulating air passageways of the stove be kept clean.

Mobile home installation should be done in accordance with the Manufactured Home and Safety Standard (HUD), CFR 3280, Part 24.

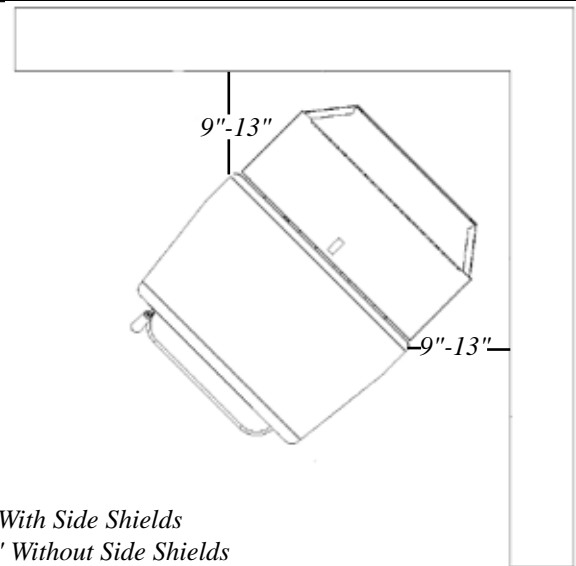

9" With Side Shields
13" Without Side Shields

Fig. 3

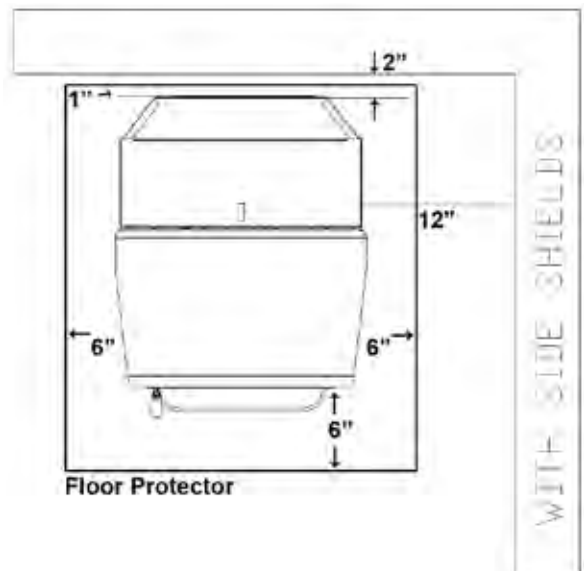

Fig. 4

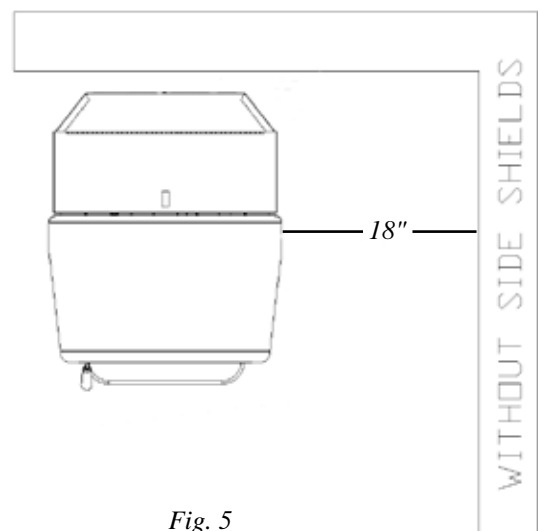

Fig. 5

Venting

Requirements for Terminating the Venting

WARNING: Venting terminals must not be recessed into a wall or siding.

NOTE: Only pellet vent pipe wall pass-throughs and fire stops should be used when venting through combustible materials.

NOTE: Always take into consideration the effect the prevailing wind direction or other wind currents will cause with flyash and /or smoke when placing the termination.

In addition, the following must be observed:

A. The clearance above grade must be a minimum of 18".¹

B. The clearance to a window or door that may be opened must be a minimum of 48".¹

(with outside air installed, 18")

C. A 12" clearance to a permanently closed window is recommended to prevent condensation on the window.

D. The vertical clearance to a ventilated soffit located above the terminal within a horizontal distance of 2 feet (60 cm) from the center-line of the terminal must be a minimum of 18".

E. The clearance to an unventilated soffit must be a minimum of 12".

F. The clearance to an outside corner is 11" from center of pipe.

G. The clearance to an inside corner is 12".

H. A vent must not be installed within 3 feet (90 cm) above a meter/regulator assembly when measured from the horizontal center-line of the regulator.¹

I. The clearance to service regulator vent outlet

must be a minimum of 6 feet.¹

J. The clearance to a non-mechanical air supply inlet to the building or the combustion air inlet to any other appliance must be a minimum of 48".¹

K. The clearance to a mechanical air supply inlet must be a minimum of 10 feet.¹

(with outside air installed, 6 feet)

L. The clearance above a paved sidewalk or a paved driveway located on public property must be a minimum of 7 feet.^{1,2}

M. The clearance under a veranda, porch, deck or balcony must be a minimum of 12 inches.^{1,3}

NOTE: The clearance to vegetation and other exterior combustibles such as mulch is 36" as measured from the center of the outlet or cap. This 36" radius continues to grade or a minimum of 7 feet below the outlet.

¹Certain Canadian and or Local codes or regulations may require different clearances.

²A vent shall not terminate directly above a side-walk or paved driveway which is located between two single family dwellings and serves both dwellings.

³Only permitted if veranda, porch, deck, or balcony is fully open on a minimum of 2 sides beneath the floor.

NOTE: Where passage through a wall, or partition of combustible construction is desired, the installation shall conform to CAN/CSA-B365. (if in Canada)

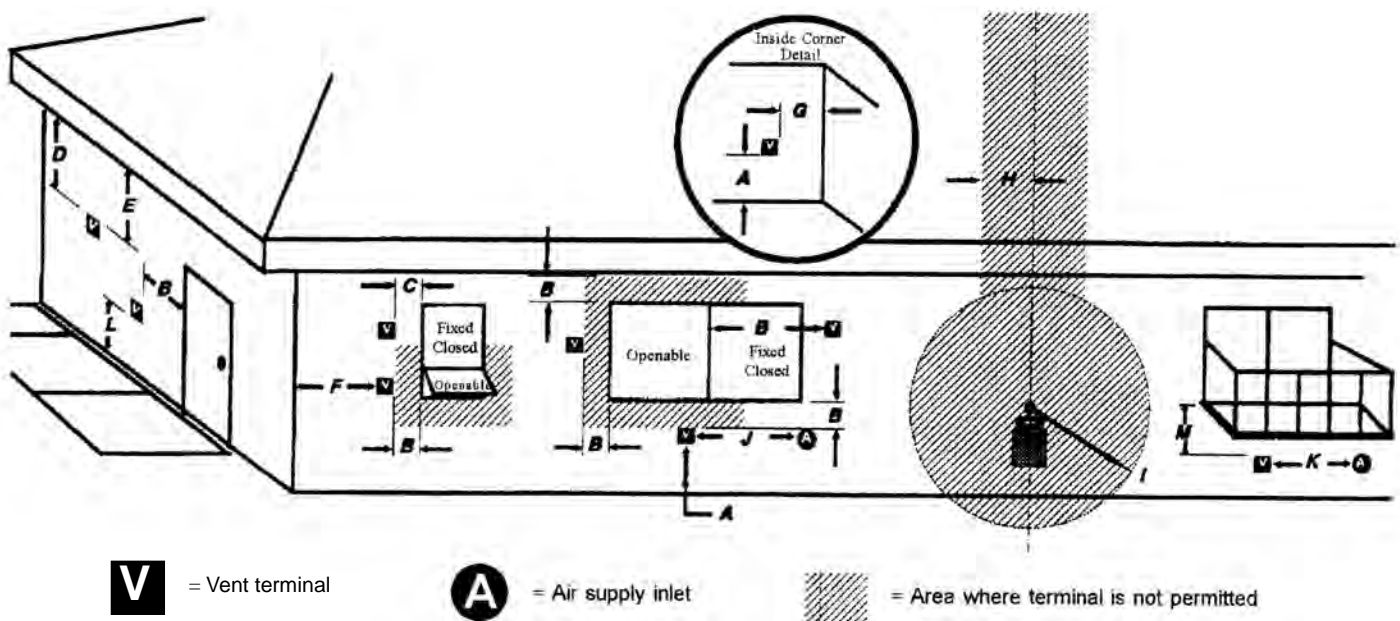

Venting

IMPORTANT NOTICE

Pellet Vent "L" or "PL" Vent Pipe Must be used.

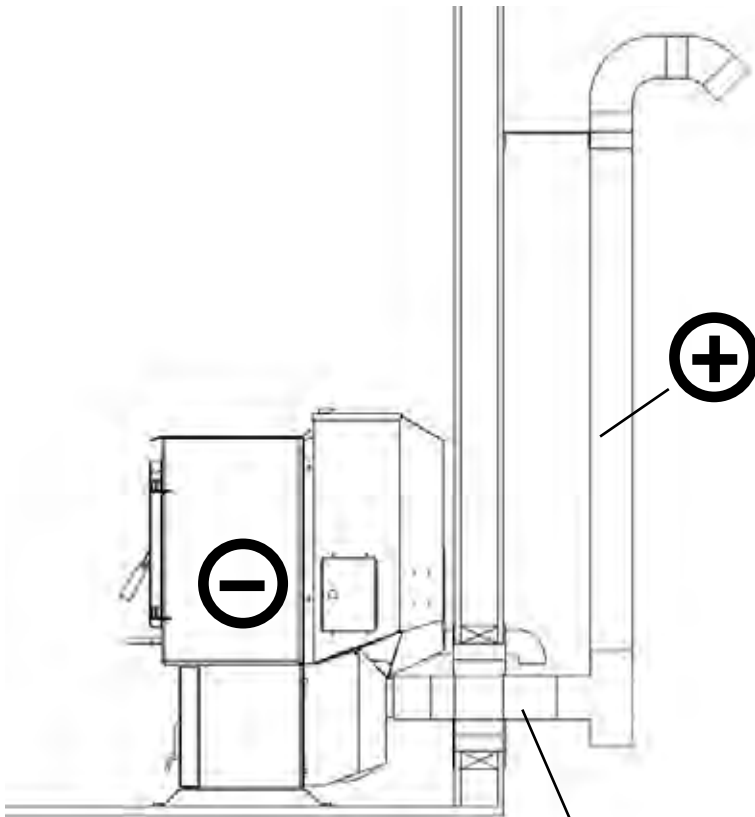

Fig. 6

⊕ = Positive static pressure
⊖ = Negative static pressure

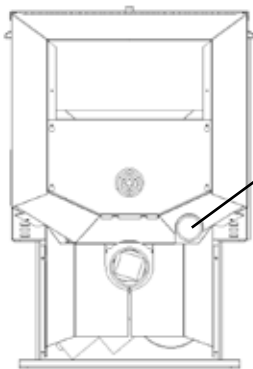
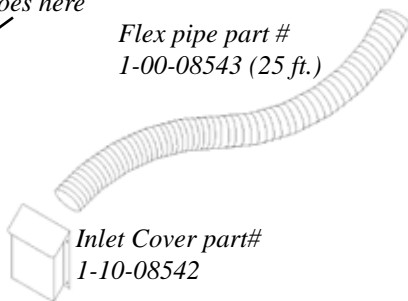

Fig. 7

Outside air flex pipe goes here

Flex pipe part #
1-00-08543 (25 ft.)



Inlet Cover part#
1-10-08542

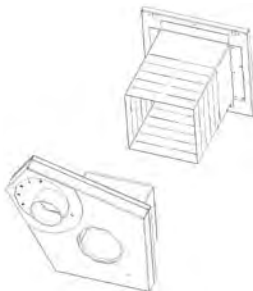

The Harman Direct Vent Wall Passthrough allows the proper protection of the wall and brings outside air to the stove with one component. Part # 1-00-677077 is all you need. (fits only 3" pellet pipe)

A combustion blower is used to extract the combustion gases from the firebox. This causes a negative pressure in the firebox and a positive pressure in the venting system as shown in fig. 6. The longer the vent pipe and more elbows used in the system, the greater the flow resistance. Because of these facts we recommend using as few elbows as possible and 15 feet or less of vent pipe. The maximum horizontal run should not exceed 48". If more than 15 feet of pipe is needed, the diameter should be increased from 3" to 4" because a larger pipe causes less flow resistance. **Be sure to use approved pellet vent pipe wall and ceiling pass through fittings to go through combustible walls and ceilings.** Be sure to use a starting collar to attach the venting system to the stove. **The starting collar must be sealed to the stove with high temp silicone caulking.**

Vent Pipe

Pellet vent pipe (known as type "L" or "PL" vent) is constructed of two layers with air space between the layers. This air space acts as an insulator and reduces the outside surface temperature to allow a clearance to combustibles of only 3 inches. The sections of pipe lock together to form an air tight seal in most cases; however, in some cases a perfect seal is not achieved. For this reason and the fact that the P61 operates with a positive vent pressure **we specify that the joints also be sealed with high temp silicone.**

Outside Air

Outside air is optional except in mobile homes and where building codes require. The benefit of outside air is mainly noticed in small very tight houses.

To install outside air use 2 3/8" I.D. flex pipe part number 1-00-08543 (25 ft.). There is a break-away hole on the rear panel which must be removed before connecting the flex pipe. The pipe should be run outside and terminate to the side or below the vent pipe outlet so the flue outlet is more than 12" from the inlet cover. The maximum length run of this pipe is 15 feet. If a longer run is needed the size must be increased to 3". Inlet cover part number 1-10-08542 should be used to keep birds, rodents etc. out of the pipe.

HRV

When installing in a house with a Heat Reclaiming Ventilation System (HRV) be sure the system is balanced and is not creating a negative pressure in the house.

Venting

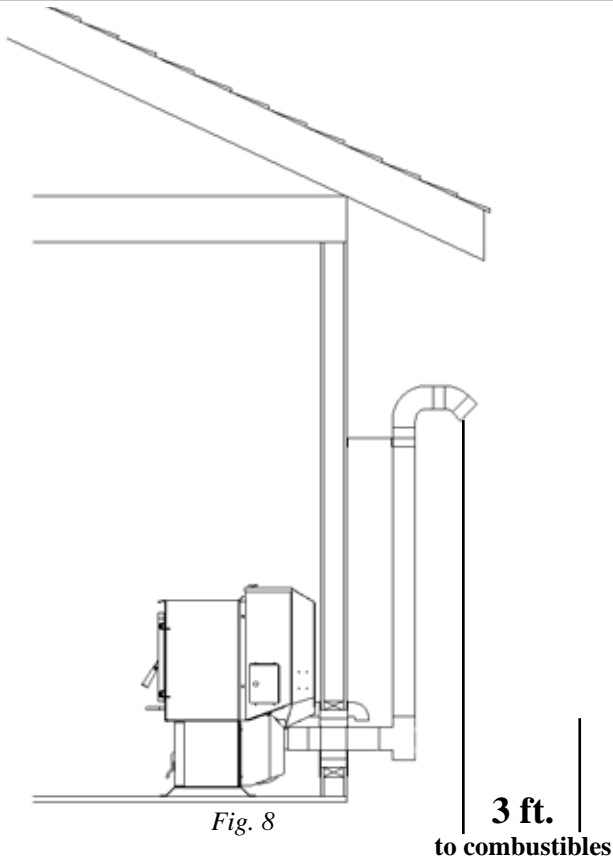

#1 Preferred method

This method provides excellent venting for normal operation and allows the stove to be installed closest to the wall. Two inches from the wall is safe; however, four inches allows better access to remove the rear panel. The vertical portion of the vent should be three to five feet high. This vertical section will provide natural draft in the event of a power failure.

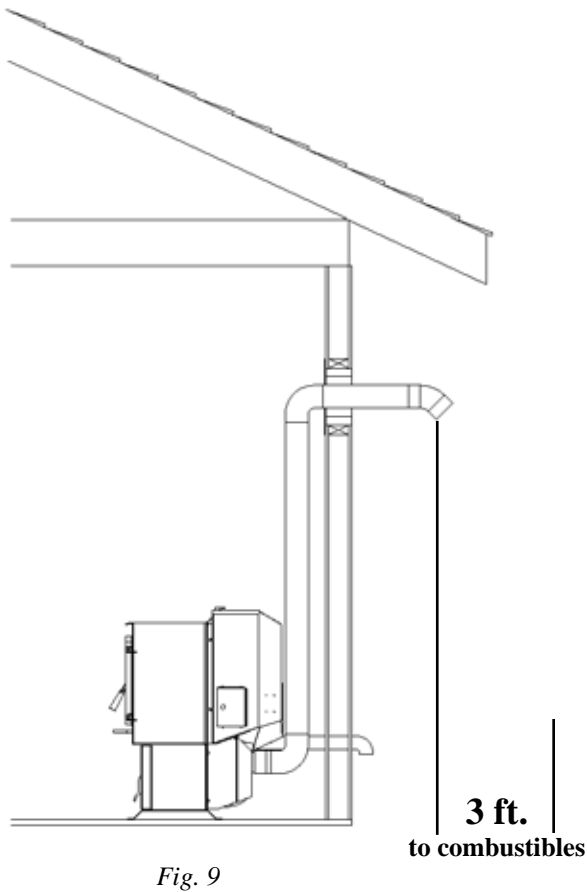

#2 Preferred method

This method also provides excellent venting for normal operation but requires the stove to be installed farther from the wall. The vertical portion of the vent should be three to five feet high and at least three inches from a combustible wall. This vertical section will provide natural draft in the event of a power failure.

Venting

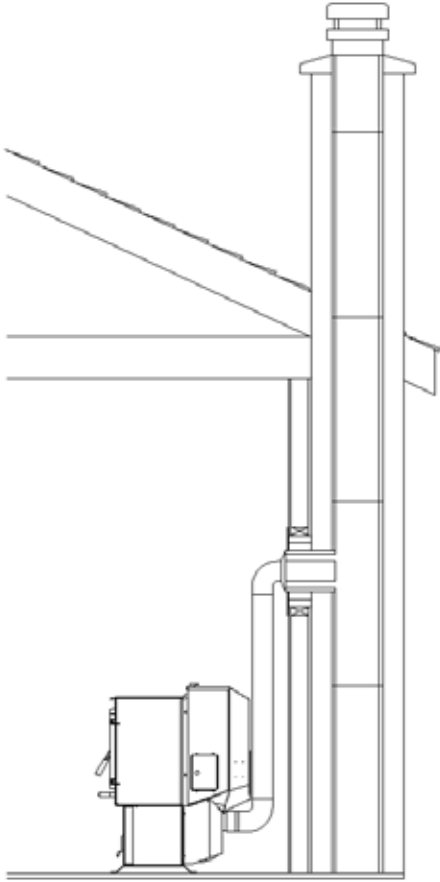

Fig. 10

#4 Installing into an existing chimney

This method provides excellent venting for normal operation. This method also provides natural draft in the event of a power failure. If the chimney condition is questionable you may want to install a liner as in method #7. Check with your local codes to be sure a liner is not mandatory.

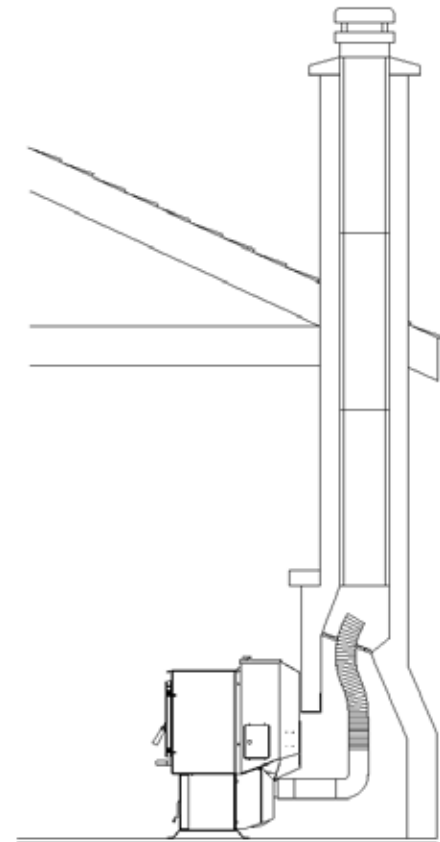

Fig. 11

#5 Installing into an existing fireplace chimney

This method provides excellent venting for normal operation. This method also provides natural draft in the event of a power failure.

The damper area must be sealed with a steel plate or fiberglass. A cap should be installed on the chimney to keep out rain. If the chimney condition is questionable you may want to install a liner all the way to the top as in method #6. Check with your local codes to be sure a liner is not mandatory.

Venting

#6 Installing into an existing fireplace chimney

This method provides excellent venting for normal operation. This method also provides natural draft in the event of a power failure.

Some places in the US and Canada it is required that the vent pipe extend all the way to the top of the chimney.

In this method a cap should also be installed on the chimney to keep out rain. Be sure to use approved pellet vent pipe fittings. Seal pipe joints with silicone in addition to the sealing system used by the manufacturer. Pipe size should be increased to 4" using this method.

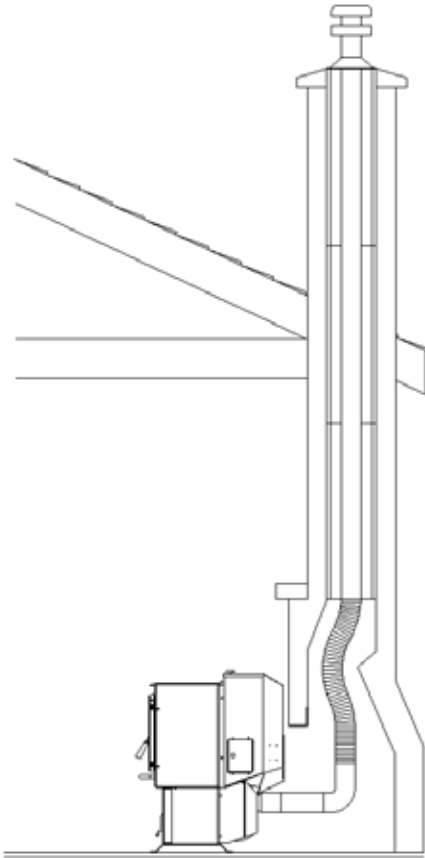

Fig. 12

#7 Installing into an existing chimney

This method provides excellent venting for normal operation. This method also provides natural draft in the event of a power failure.

Some places in the US and Canada it is required that the vent pipe extend all the way to the top of the chimney. The pipe or liner inside the chimney should be 4" diameter.

In this method a cap should also be installed on the chimney to keep out rain.

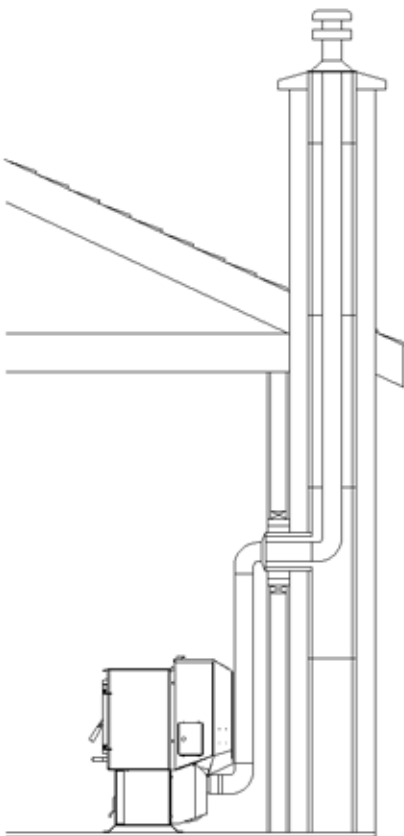

Fig. 13

Venting

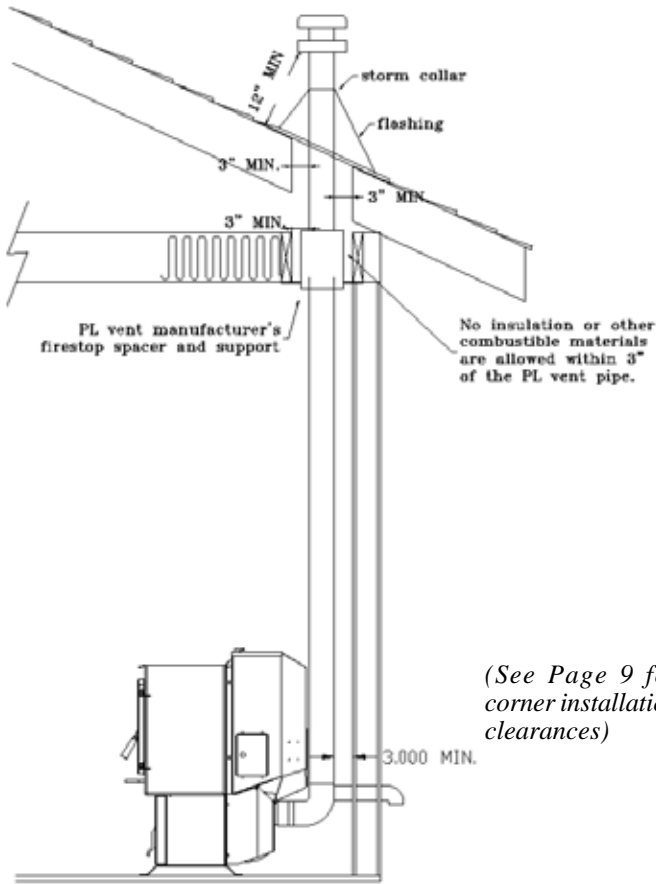

Fig. 14

#8 Installing through the ceiling vent

Through the ceiling vent, follow the vent manufacturers recommendations when using wall and ceiling pass throughs.

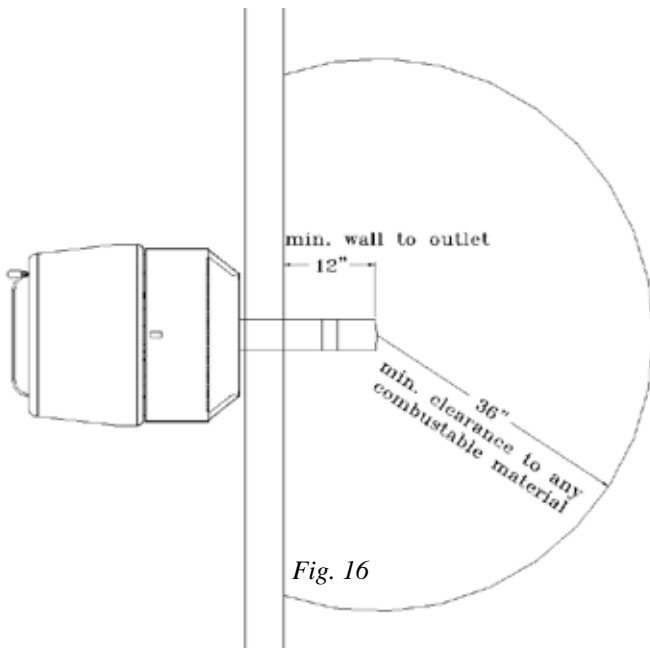

Fig. 16

Minimum flue vent configuration

It is recommended that outside air be installed with this venting configuration.

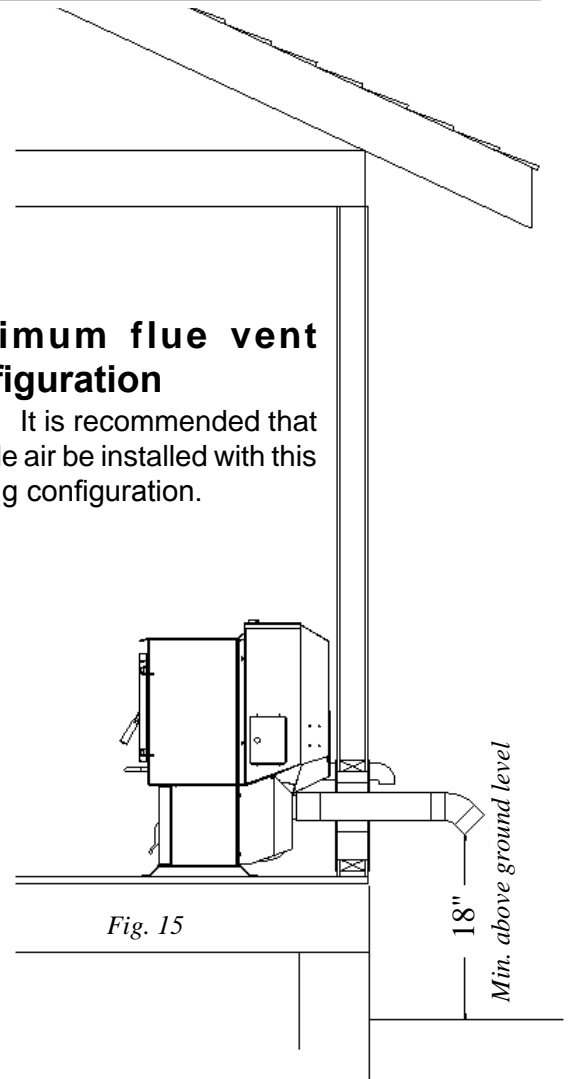

Fig. 15

DO NOT INSTALL A FLUE DAMPER IN THE EXHAUST VENTING SYSTEM OF THIS UNIT.

DO NOT CONNECT THIS UNIT TO A CHIMNEY FLUE SERVING ANOTHER APPLIANCE.

INSTALL VENT AT CLEARANCES SPECIFIED BY THE MANUFACTURER

CAUTION
THE STRUCTURAL INTEGRITY OF THE MOBILE HOME FLOOR, WALL, AND CEILING/ROOF MUST BE MAINTAINED.

CAUTION
THE STOVE IS HOT WHILE IN OPERATION. KEEP CHILDREN, CLOTHING AND FURNITURE AWAY. CONTACT MAY CAUSE SKIN BURNS.

P61-2 MANUAL START UP

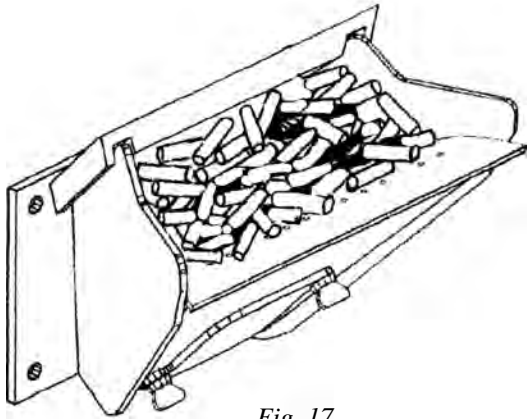

Fig. 17

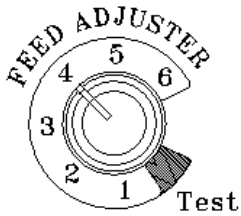

Fig. 18

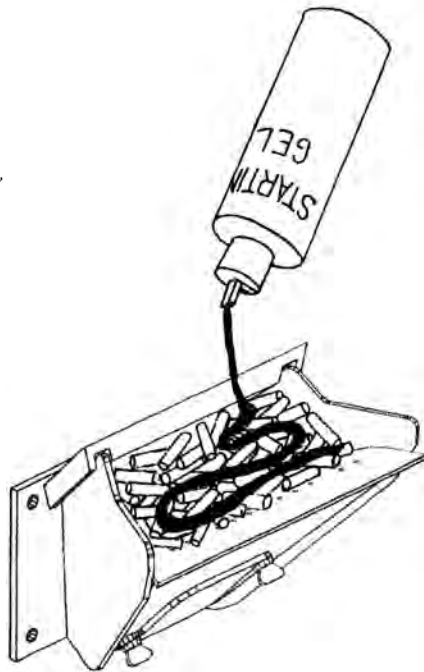

Fig. 19

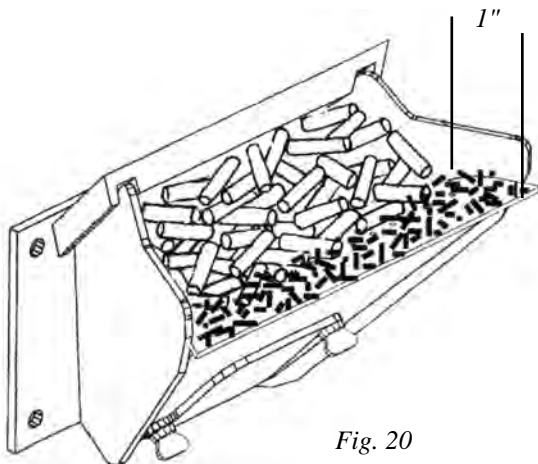

Fig. 20

Operation

Starting First Fire

Be sure the power cord is plugged into a 120 volt receptacle. This can be verified by the red power light on the control panel.

Be sure there is no fuel or other combustibles in the ash pan prior to lighting.

Fill the hopper with pellets.

Fill the burn pot with pellets to a level just short of overflowing, fig. 17.

Adjust feed rate. If this is your first fire or you are trying different pellets, set the feed adjuster to "4", fig. 18. This is a conservative number and will probably need to be increased. After you know a feed rate setting that works well, use that setting. Remember, too high of a feed rate will waste fuel.

Turn Mode selector to "OFF" and then to "Stove Temp". This will turn the combustion blower to high. When starting a fire always turn the mode selector to "OFF" before selecting the desired mode. This resets the control for start-up.

Turn Temp Dial to 7. This will allow the stove to burn at maximum for feed rate adjusting purposes.

Apply starting gel to pellets in burn pot and **light** the gel. Close the door after lighting. At this point the distribution and combustion lights will be on and the feed motor light will be off. As the temperature of the fire increases, the feed motor light will come on and pellets will feed into the burn pot. As the stove temperature increases the distribution blower speed will increase.

After 30 to 45 minutes it may be necessary to **readjust the feed rate.** The feed rate should be adjusted so there is about one inch of ash in front of the fire, fig. 20. This is a maximum burn position and the stove may not achieve this position under normal burn rates.

"NEVER USE GASOLINE, GASOLINE-TYPE LANTERN FUEL, KEROSENE, CHARCOAL LIGHTER FLUID, OR SIMILAR LIQUIDS TO START OR "FRESHEN UP " A FIRE IN THIS HEATER. KEEP ALL SUCH LIQUIDS WELL AWAY FROM THE HEATER WHILE IN USE".

P61-2 MANUAL IGNITION/OPERATION

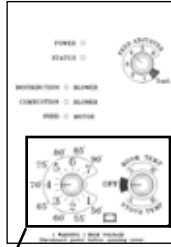
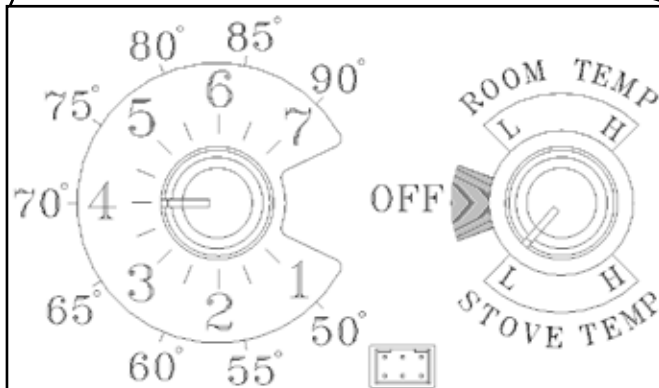
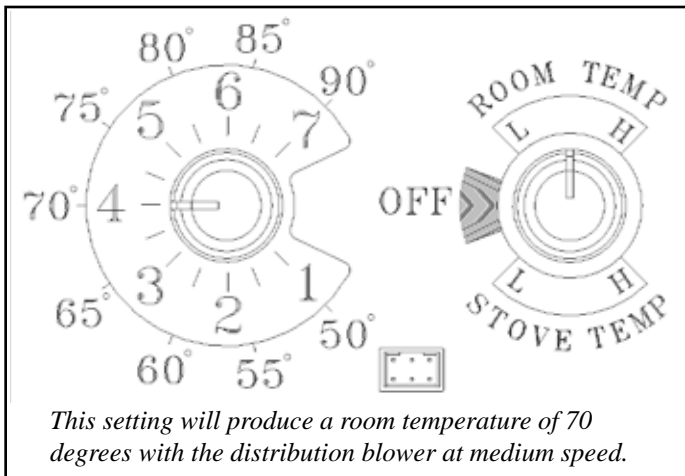

Fig. 21



This setting will produce medium heat with the distribution blower on "low".



This setting will produce a room temperature of 70 degrees with the distribution blower at medium speed.

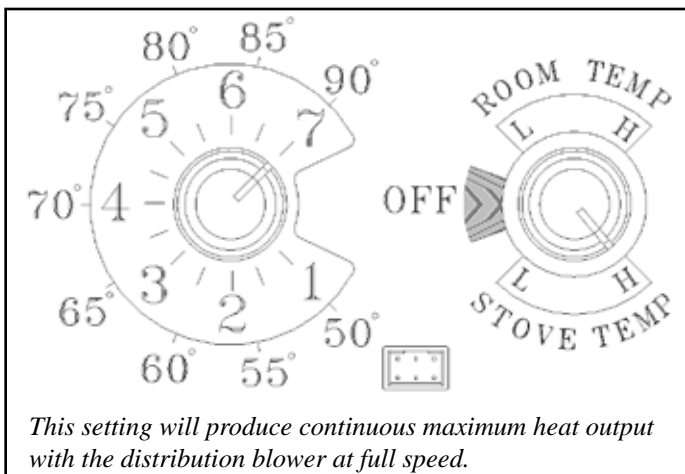

This setting will produce continuous maximum heat output with the distribution blower at full speed.

When to use "Stove Temp Mode"

In "Stove Temp Mode" the Stove Temp Dial determines the temperature of the stove. Heat output and fuel consumption will remain constant. This makes it possible to tell how long a hopper full of pellets will last. The distribution blower speed will vary according to the position of the mode selector, fig. 21.

When to use "Room Temp Mode"

In "Room Temp Mode" heat output is controlled automatically by the Room Sensing Probe. When the Room Sensing Probe calls for heat, the stove will increase output. When the Room Sensing Probe is getting close to the set temperature, the stove will begin to level off output and keep the fire burning at just the right temperature to maintain that setting.

High output is determined by the feed rate. The maximum feed rate should be set for 1" of ash in front of fire.

In "Room Temp Mode" fuel consumption is sacrificed for exact room temperature. Therefore, as it gets colder, more pellets will be burned automatically.

The distribution blower speed will vary according to the position of the mode selector, fig. 21.

Shut-Down Procedure

To kill the fire or stop burning the stove, turn the Mode Selector to "OFF". This will cause the fire to diminish and burn out. When the fire burns out and the stove cools down everything will stop.

Never pull the plug to shut down the stove, all motors will stop. This will cause incomplete combustion and smoke in the firebox. If the load door is opened the smoke will escape.

The best way to shut down the stove is to simply let it run out of pellets, then the stove will shut down automatically.

P61-2 ESP CONTROL

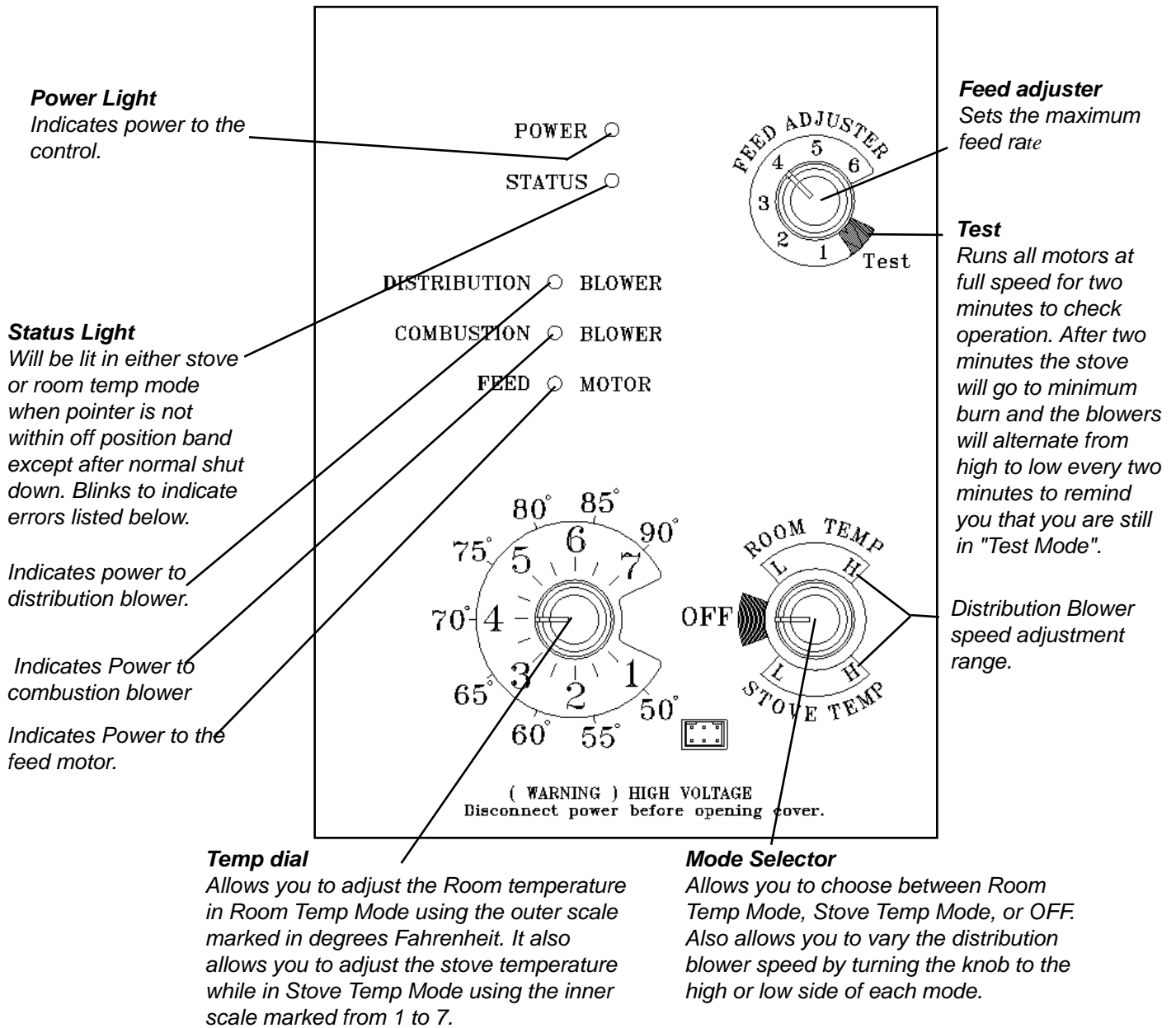

STATUS LIGHT ERROR MESSAGES:

1 Blink: Indicates control board self diagnostic failure. This requires a manual reset*.

3 Blinks: Indicates ESP (Exhaust Sensing Probe) failure. This requires a manual reset*.

4 Blinks: Can occur only in Room Temp Mode and indicates Room Sensing Probe failed or not installed. If a Room Sensing Probe is then installed the status light will automatically reset.

6 Blinks : Indicates that the control has calculated poor or incomplete combustion occurring for more than 50 minutes. See Troubleshooting section for more details.

* **Manual reset**, disconnect power cord for a few seconds and reconnect. If error still occurs call your Dealer.

Room Sensor and Rear Shield Installation

Room Sensor Installation



Fig. 22

The room sensor is a small temperature sensor on the end of a 60" wire. This sensor is installed much like a standard wall thermostat. Because it is so small, it can be hidden along the trim of a doorway or even up the leg of a coffee table. There is a remote room sensor port on the rear of the unit for easy external connection. Use standard 18-2 thermostat wire to extend the distance to the desired location (100' maximum). The room sensor should be installed in the location where you want to control the temperature.

NOTE: Distances of more than 25 feet from the unit or in another room are not recommended. The room sensor is essential for the P61's excellent efficiency.

NOTE: **It is recommended that the room sensor be installed**, even if only installed on the rear of the unit as a return air sensor.

Rear Shields

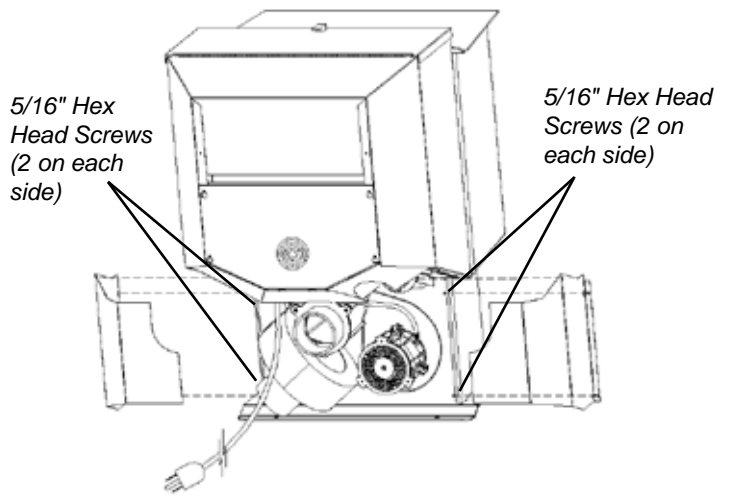

Fig. 23

The rear insulated shields are split in the middle for easy removal. Each shield has two 5/16" hex head screws that only need to be loosened (NOT REMOVED) to allow the shield to slide away from the unit. **NOTE: It is not recommended that the unit be operated with the shields removed, due to the hot and moving parts which they protect.**

Maintenance

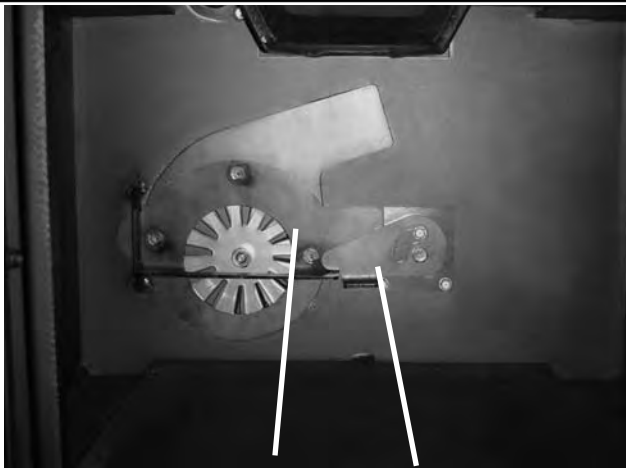

Fig. 24 Combustion Blower Cover Blower Cover Latch
Heat Exchanger Fins

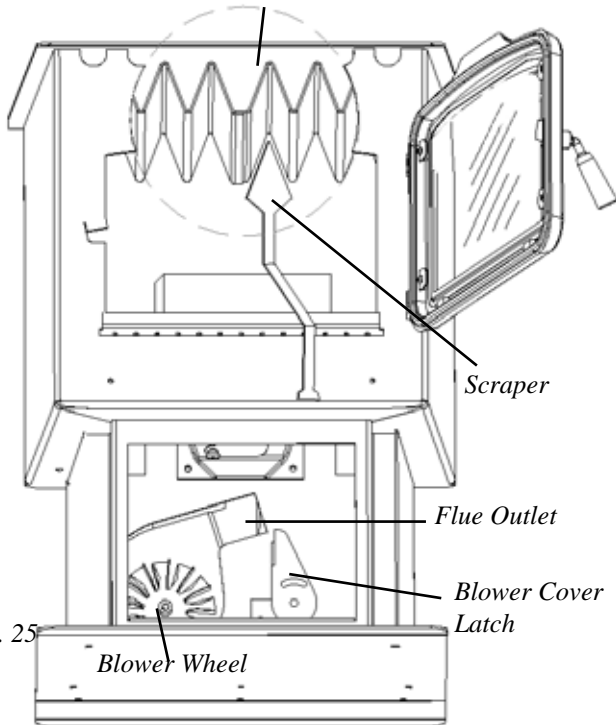

Fig. 25

The draft pressure switch senses the pressure in the hopper. Note the location of this fitting, known as the muffler. Depending on the amount of fines in the fuel, this muffler may need to be cleaned periodically. Use caution when cleaning or emptying the hopper.



Removing Ashes:

When approximately 1 ton of pellets has been burned, it will be necessary to empty the ash pan.

Ashes should be placed in a metal container with a tight fitting lid. The closed container of ashes should be placed on a noncombustible floor or on the ground, well away from all combustible materials, pending final disposal. If ashes are disposed of by burial in soil or otherwise locally dispersed, they should be retained in the closed container until all cinders have thoroughly cooled.

It is recommended that the stove is cold and shut down when removing the ash pan.

1. Pull on latch handle to open the ash door, and remove ash pan.
2. Close the ash door while dumping ashes. Use ash pan handle to carry and dispose of ashes.
3. Return the ash pan into the stove and latch the ash door securely.

Cleaning:

Scrape the burn pot surface regularly. Whenever adding fuel, it is a good time to scrape the burn pot. Using the flat end of the scraper tool, scrape under the fire to remove any carbon deposits which may be forming. The more frequent the scraping, the better performance you'll have.

The stove will need to be cleaned for approximately every 2 to 5 tons of pellets burned. The amount of pellets burned before cleaning will vary depending on the brand of pellets.

1. Shut down the stove and **disconnect the power cord** to insure that all motors are stopped.
2. Remove ash pan as described earlier.
3. Remove combustion blower cover by turning the latch vertical as shown in Fig.26 and sliding the cover out of the slot on the left (Fig.27.) This will expose the combustion blower wheel and flue outlet, (Fig.24.)
4. Clean the blower wheel with a brush and a vacuum cleaner.
5. Use a brush (Fig.30) to clean the flue, being careful not to damage the ESP probe. The flue goes straight through into the vent pipe (Fig.29) therefore, the vent pipe can also be cleaned, to some extent, through the flue outlet.
6. Reinstall the blower cover and relatch.

Maintenance

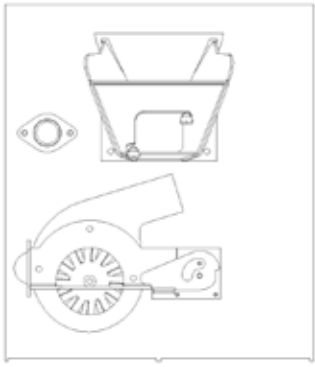

Fig. 26
Latch "closed" with blower cover in place. Burn pot clean-out is closed.

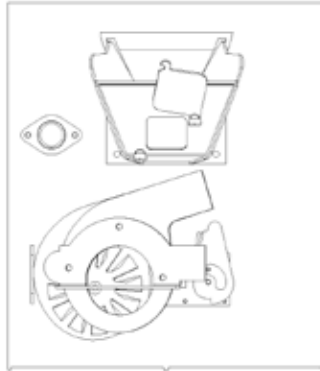

Fig. 27
Latch "open" with blower cover partly removed. Burn pot clean-out is open.

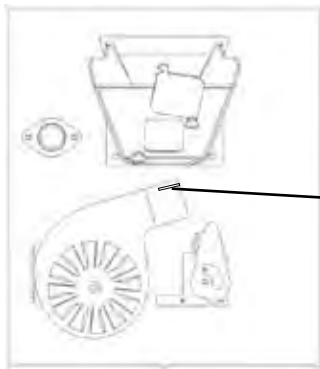
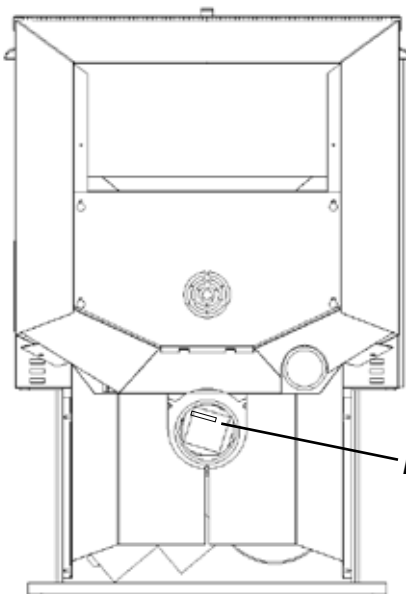

Fig. 28
Exposed blower wheel and flue opening, NOTE: ESP probe is visible.

ESP probe



Blower cover removed.



ESP Probe

Be careful not to damage ESP probe when cleaning with brush.

Fig. 29

7. Open the burn pot slide as shown, clean with vacuum and close.
8. Clean the heat exchanger with the scraper as shown in Fig. 25.
9. Brush or scrape the inside of the stove to remove fly ash.
10. Scrape the burnpot with the flat end of the provided scraper. Fig.31.
11. Slide the ash pan into stove and re-latch the ash pan door.

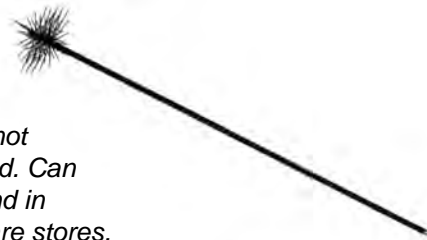

Brush not supplied. Can be found in hardware stores.
Fig. 30

Soot and Fly Ash

The products of combustion will contain small particles of fly ash. The fly ash will collect in the exhaust venting system and restrict the flow of the flue gases. Incomplete combustion, such as occurs during startup, shutdown, or incorrect operation of the room heater, will lead to some soot formation which will collect in the exhaust venting system. The exhaust venting system should be inspected at least once every year to determine if cleaning is necessary.



Fig. 31

Trouble-Shooting

FEEDER DOES NOT FEED

1. No pellets in hopper.
2. Feed motor will not run until ESP senses 165 deg. F. Maybe you did not put enough pellets in the burn pot before lighting the fire.
3. Feed motor has failed.
4. Something is restricting flow in the hopper or causing the slide plate to stick.
5. Firebox draft may be too low for low draft pressure switch in feeder circuit to operate. Check for closed doors, loose or missing gasket on doors or hopper lid, faulty pressure switch.

PARTIALLY BURNED PELLETS

1. Feed rate too high.
2. Draft too low. (Check burn pot clean-out slide and door gasket).
3. Burn pot or heat exchanger fins may need to be cleaned.
4. Combination of all of the above.

SMOKE SMELL

Seal the vent pipe joints and connection to stove with high temp silicone.

FIRE HAS GONE OUT

1. No pellets in hopper.
2. Feed rate too low.
3. Something is restricting fuel flow.
4. Feed motor or draft motor has failed.
5. Power failure or blown fuse.

SMOKE IS VISIBLE COMING OUT OF VENT

1. Air-fuel ratio is too rich.
 - A. Feed rate too high.
 - B. Draft too low caused by a gasket leak.

LOW HEAT OUTPUT

1. Feed rate too low
2. Draft too low because of gasket leak.
3. Poor quality or damp pellets
4. Combination of 1. and 2.

Helpful Hints

Cleaning Burn Pot

Whenever your stove is not burning, take the opportunity to scrape the burn pot to remove carbon buildup. A vacuum cleaner is handy to remove the residue. Be sure the stove is cold if you use a vacuum.

Carbon buildup can be scraped loose with the fire burning using the special tool provided with your stove. Scrape the floor and sides of the burn pot. The carbon will be pushed out by the incoming fuel. Always wear gloves to do this.

Removing Ashes

Turn the Temperature Dial to minimum approximately 30 minutes before removing ashes. This will result in a cooler stove and ash pan.

Maximum feed settings are not needed in most cases. Operating in the normal range is recommended when maximum heat output is not required. The ESP probe prevents the stove from being over-fired.

Keep the stove free of dust and dirt.

Fuel

Pellet fuels are put into 3 categories in terms of ash content. Premium at 1% or less, Standard at 3% or less and all others at 3% or more.

The P61 is capable of burning all 3 categories of pellets due to a patented feeder and burn pot system.

It should be noted, however, that higher ash content will require more frequent ash removal and may provide less BTU's per lb. Normally, standard and high ash pellets cost less than premium pellets and can be cost effective when burned in the P61.

The moisture content must not exceed 8%. Higher moisture will rob BTU's and may not burn properly.

P61-2 Feeder

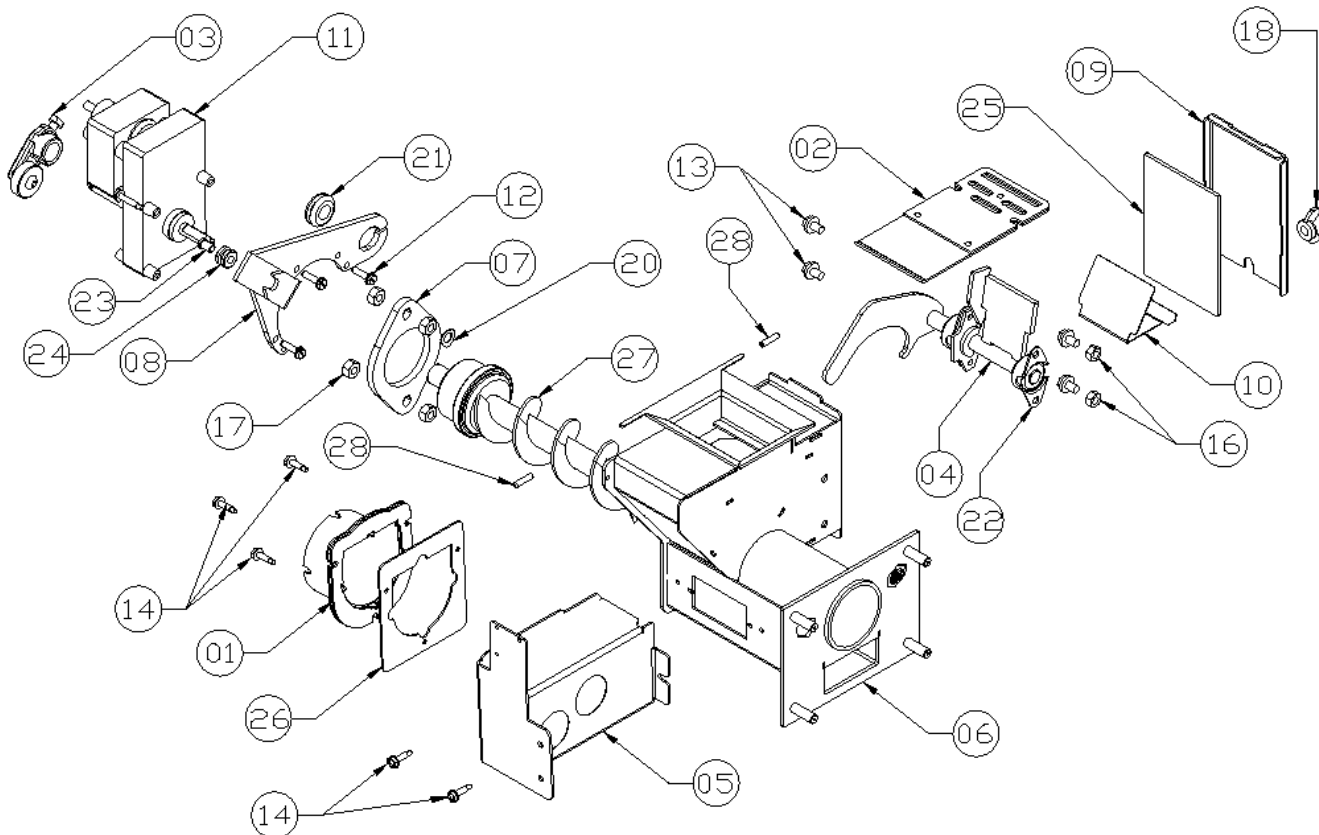

| ITEM | QTY | Part No. | Part Name |
|------|-----|-----------------|--|
| 01 | 01 | 1-10-06810 | PELLET AIR INTAKE ASSY |
| 02 | 01 | 1-10-677121 | SLIDE PLATE ASSY |
| 03 | 01 | 1-10-677154 | ULFEEDER CAM BLOCK LONG ASSY |
| 04 | 01 | 1-10-677189 | P61/P61A/P68 ULFEEDER PUSHER ARM WELDMENT 69X4 |
| 05 | 01 | 1-10-72222 | PB105-P38-43-PC45/61/68/PF100/HF60 UL FEEDR AIR INT WELD |
| 06 | 01 | 1-10-724132 | ULTRALIGHT FEEDER WELDMENT |
| 07 | 01 | 2-00-04035 | PELLET FEEDER BEARING RETAINER |
| 08 | 01 | 2-00-247406 | UL FEEDER GEARMOTOR BRACKET |
| 09 | 01 | 2-00-677122 | ULFEEDER COVER SHORT |
| 10 | 01 | 2-00-677138 | FINES DEFLECTOR |
| 11 | 01 | 3-20-60906 | PELLET FEEDER GEARMOTOR-4RPM |
| 12 | 03 | 3-30-110240753 | HWH TCS 10-24 X 3/4" BLACK |
| 13 | 04 | 3-30-2252003813 | 8.2 FLNG 1/4-20 X 3/8" |
| 14 | 05 | 3-30-511007517 | TEK SCREW #10 X 3/4" |
| 15 | 01 | 3-30-511010017 | HWH TEKS #10 X 1" < NOT SHOWN > |
| 16 | 02 | 3-30-80252013 | FHN 1/4-20 Z5 |
| 17 | 04 | 3-30-80311813 | FHN 5/16-18 |
| 18 | 01 | 3-30-8131181 | 5/16-18 WING NUT |
| 19 | 01 | 3-31-03065 | PRY OUT PLUG < NOT SHOWN > |
| 20 | 01 | 3-31-453013 | 5/8" SPRING WASHER-PLATED |
| 21 | 01 | 3-31-2761 | HALF INCH GROMMET |
| 22 | 01 | 3-31-3614087 | PILLOW BLOCK |
| 23 | 01 | 3-31-910145157 | NYLON SPACER GEARMOTOR BKT |
| 24 | 01 | 3-31-960026 | GROMMET GEARMOTOR BKT |
| 25 | 01 | 3-44-677155 | ULFEEDER COVER GASKET |
| 26 | 01 | 3-44-72224 | UL FEEDER AIR INTAKE EPDM GASKET |
| 27 | 01 | 3-50-00565 | ULFEEDER AUGER ASSY |
| 28 | 02 | 3-99-125 | .093 X 3/4" MASKING CAP |

P61-2 Specifications

Specifications

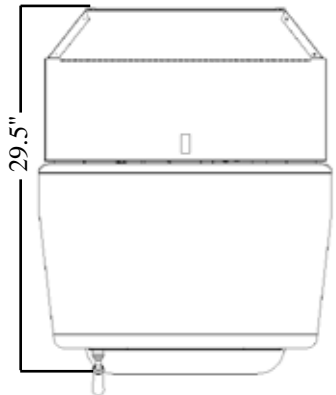
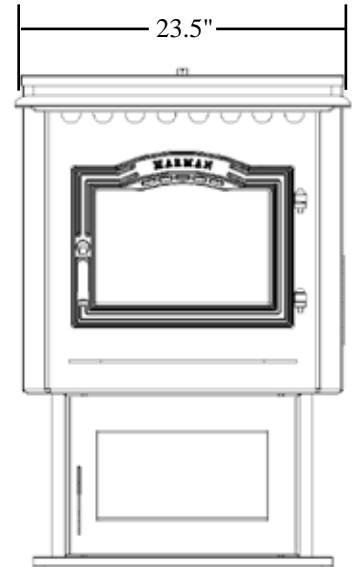
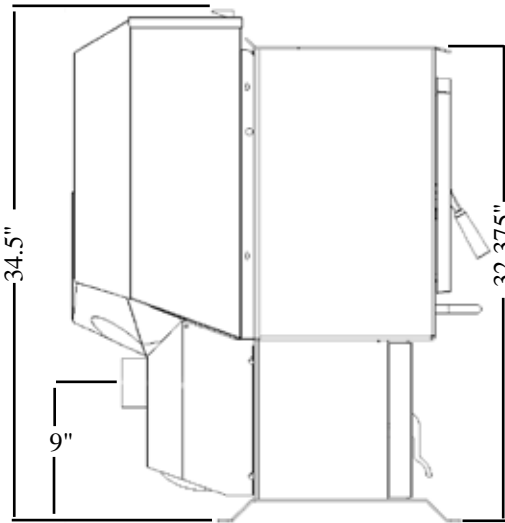
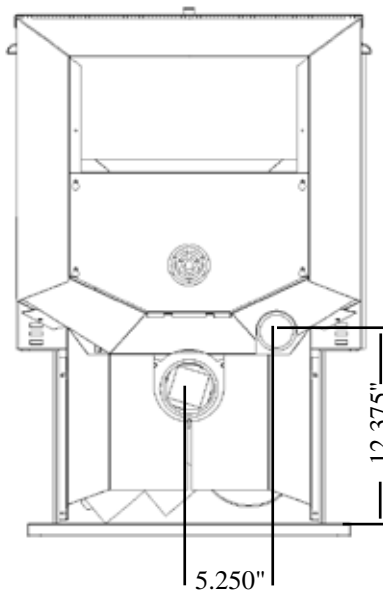

| | |
|-------------------------|----------------------------------|
| Weight | 249 lbs. |
| Blower | 135 cfm |
| Feed Rate | .75 to 7.5 lbs. per hr. |
| Hopper Capacity | 72 lbs. |
| Fuel | Wood Pellets |
| Flue Size | 3 inch |
| Outside Air Size | 2 3/8 in. Inside diameter |
| On-Board Fuse | 6 amp |

P61-2 Wiring Diagram

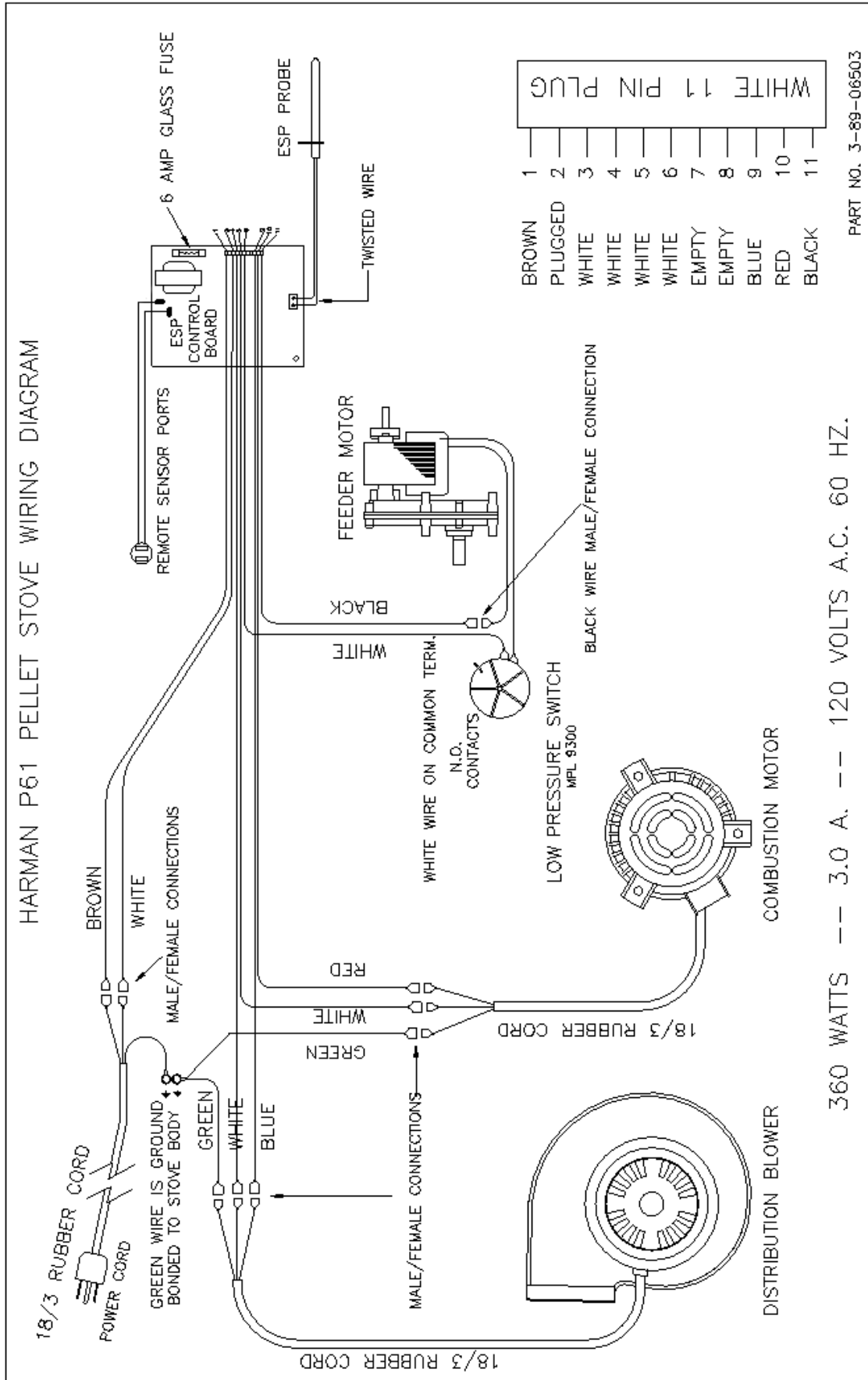

360 WATTS --- 3.0 A. --- 120 VOLTS A.C. 60 HZ.

Door Options

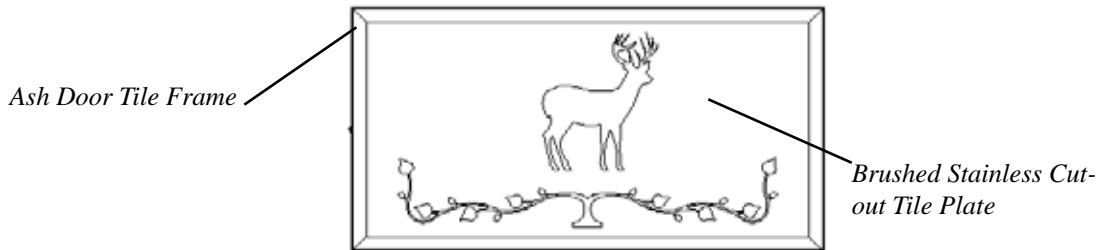
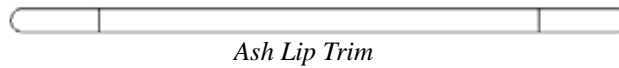
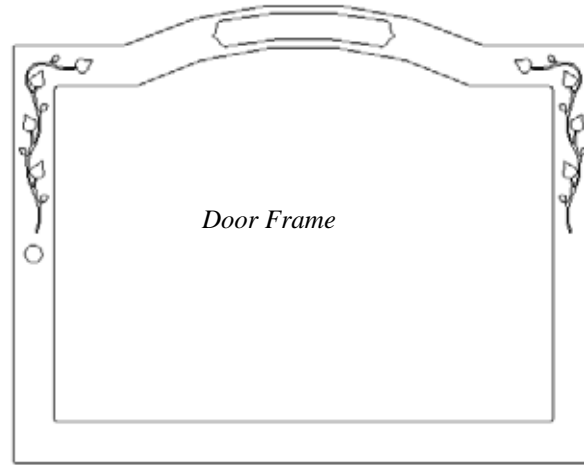

Optional Trim

The door trim kit includes the door frame, the ash lip trim, and the ash door tile frame. Available in brushed stainless, gold or bright nickel, they add a beautiful accent to your stove. To install, lay the frame face down on a soft surface. Drill the four holes in the door using the bit provided. You'll see there are dimples in the cast iron showing where to drill. Fasten the door frame by inserting the 4 threaded posts on the frame through the door. The posts should line up with the 4 holes located at the corners of the door. Once the posts are through the door, fasten frame with 4 nuts and tighten until the frame is snug.

To install ash lip trim, simply slide the trim over the ash lip and into the groove on the trim.

The ash door tile frame can be used with or without the optional decorative tile. Slide the spring clip into the channel on one end of the frame. Place the frame into the recessed area on the door inserting the clip end first. The tension of the spring holds the frame in place.

Decorative Tile

Decorative tile is available in several designs. The tile installs behind the trim on the ash door. Along with the above pictured cut-out tile plate, there are ten different picture tiles and four slate tiles available. See your dealer for choices.

Cleaning Plated Trim

Gold or nickel plated hardware should never be buffed or polished. Abrasive cleansers and metal polishes will remove the plating and therefore should never be used. If the plating needs to be cleaned, wait until the stove is completely cool, then use a sponge, soap and water to gently remove dirt and stains. Before relighting the stove, remove all soap residue and wipe dry.

OPTIONS

Side Heat Shields

Side heat shields are available to reduce the clearance to combustible materials.

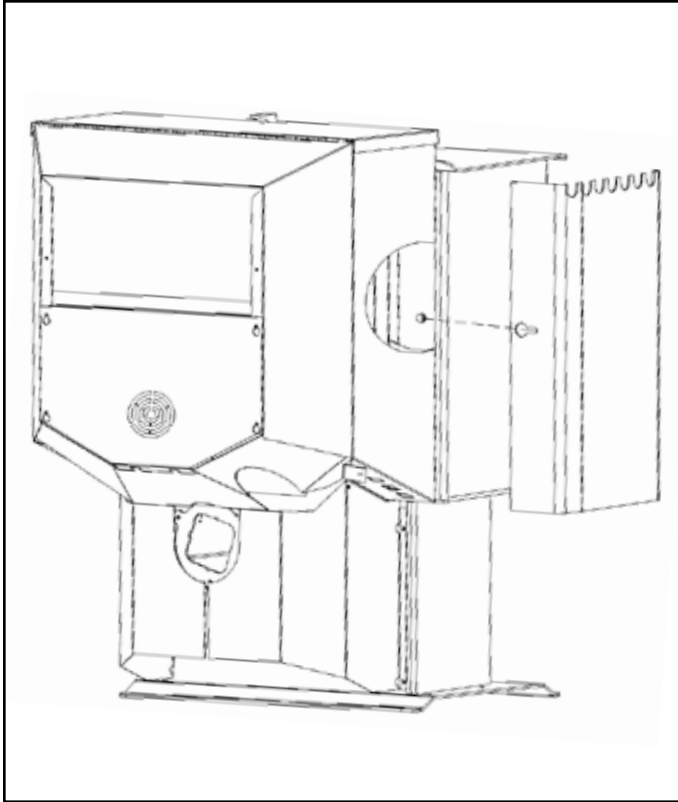

Hopper Extension

The hopper extension allows you to put more pellet fuel in the hopper and extends the burn time on one load of pellets. The hopper extension adds 60 pounds to the existing 72 pound hopper capacity, allowing you to load 132 pounds of pellets at one time.

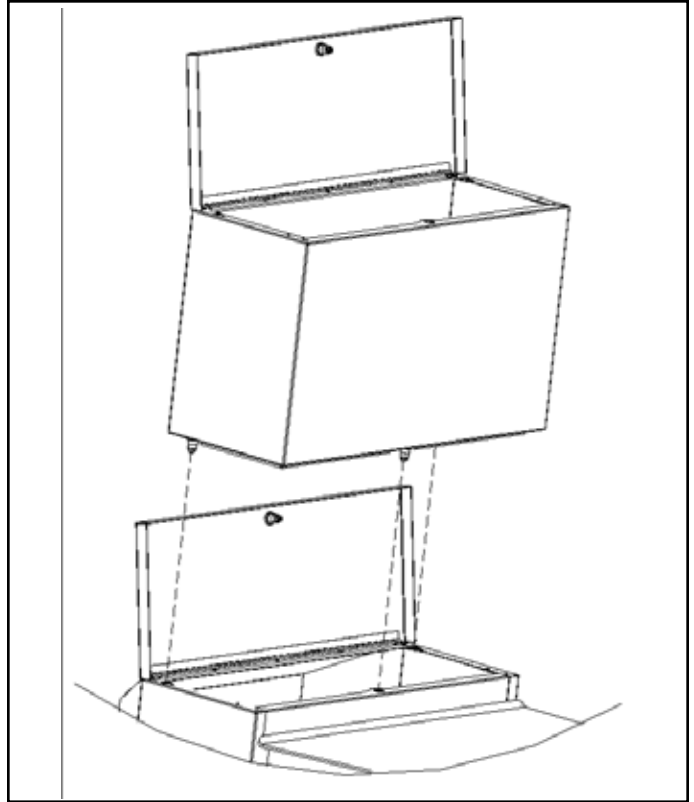

P61 Parts List

| <u>Description</u> | <u>Part Number</u> |
|--|---|
| Hopper Gasket(6 ft.) | 0-88-00248 |
| Ash Pan Assembly | 1-10-05800 |
| Burn Pot Weldment | 1-10-05802 |
| Right Rear Shield | 2-00-06468-1P |
| Left Rear Shield | 2-00-06468-2P |
| Arrow Scraper | 2-00-773850 |
| Flame Guide | 3-00-08534 |
| Wiring Harness Assembly | 3-20-08727 |
| Thermister Probe | 3-20-00744(blk wire) 3-20-00844(red wire) |
| Room Sensor | 3-20-00906 |
| Circuit Board | 3-20-05378 or 3-20-05890 (match old #) |
| Differential Switch | 3-20-6866 |
| 5" Double Fan Blade | 3-20-502221 |
| Combustion Blower | 3-21-08639 |
| Distribution Blower | 3-21-22647 |
| Hopper Lid Latch | 3-31-199110 |
| 3/16" Rubber Washer (for Hopper Lid) | 3-31-90131101 |
| Power Cord | 3-20-39685 |
| Manual Ignite Label (Control Panel Door) | 3-90-05802 |
| Fire Brick (3) | 3-40-900450125 |
| White/Black Control Knob(3) | 3-31-605 |
| Control Knob Shaft(3) | 3-31-015 |
| Front Glass | 3-40-950133125 |
| Burn Pot Gasket(2) | 3-44-00409 |
| Tailpipe Gasket | 3-44-06179 |
| Wiring Diagram | 3-89-06503 |
| Control Panel Sticker | 3-90-08646 |
| Owner's Manual | 3-90-05810 |
| Hopper Lid Label | 3-90-08416 |
| Hopper Throat Gasket | 3-44-677185 |
| Hopper Muffler | 3-40-6618, Fitting 3-40-1818 |

| | | |
|-----------------|------------------------------|------------------------|
| <u>Options:</u> | Hopper Extension Assembly | 1-00-08636 |
| | Direct Vent Wall Passthrough | 1-00-677077 |
| | Outside Air Assembly | 1-10-08542 |
| | Inlet Cover | 1-10-08543 |
| | 3' Flex Pipe | 1-00-08543 |
| | Log Set | 3-40-5647 |
| | Trim Kit | 1-00-06802 |
| | Tile Pack(1 piece) | 3-43-12601(10 choices) |

Harman Gold Warranty

HARMAN GOLD WARRANTY 6 YEAR TRANSFERABLE LIMITED WARRANTY (Residential) 1 YEAR LIMITED WARRANTY (Commercial)



Harman Home Heating warrants its products to be free from defects in material or workmanship, in normal use and service, for a period of 6 years from the date of sales invoice and for mechanical and electrical failures, in normal use and service, for a period of 3 years from the date of sales invoice.

If defective in material or workmanship, during the warranty period, Harman Home Heating will, at its option, repair or replace the product as described below.

The warranty above constitutes the entire warranty with respect to Harman Home Heating products. HARMAN HOME HEATING MAKES NO OTHER WARRANTY, EXPRESSED OR IMPLIED, INCLUDING "ANY" WARRANTY OF MERCHANTABILITY, OR WARRANTY OF FITNESS FOR A PARTICULAR PURPOSE. No employee, agent, dealer, or other person is authorized to give any warranty on behalf of Harman Home Heating. This warranty does not apply if the product has been altered in any way after leaving the factory. Harman Home Heating and its agents assume no liability for "resultant damages of any kind" arising from the use of its products. In addition, the manufacturer and its warranty administrator shall be held free and harmless from liability from damage to property related to the operation, proper or improper, of the equipment.

THERE ARE NO WARRANTIES WHICH EXTEND BEYOND THE DESCRIPTION ON THE FACE HEREOF.

THESE WARRANTIES APPLY only if the device is installed and operated as recommended in the user's manual.

THESE WARRANTIES WILL NOT APPLY if abuse, accident, improper installation, negligence, or use beyond rated capacity causes damage.

HOW TO MAKE A CLAIM - Any claim under this warranty should be made to the dealer from whom this appliance was purchased. Then contact is made with manufacturer, giving the model and serial numbers, the date of purchase, your dealer's name and address, plus a simple explanation of the nature of the defect. Extra costs such as mileage and overtime are not covered. Nuisance calls are not covered by these warranties.

THIS WARRANTY IS LIMITED TO DEFECTIVE PARTS - REPAIR AND/OR REPLACEMENT AT HARMAN HOME HEATING'S OPTION AND EXCLUDES ANY INCIDENTAL AND CONSEQUENTIAL DAMAGES CONNECTED THEREWITH.

WARRANTY EXCLUSIONS: Failure due, but not limited to, fire, lightning, acts of God, power failures and/or surges, rust, corrosion and venting problems are not covered. Damage and/or repairs including but not limited to; remote controls, filters, fuses, knobs, glass, ceramic brick panels, ceramic fiber afterburners, door packing, tile, ceramic log sets, paint, batteries or battery back-up and related duct work are not covered. Also excluded from this warranty are consumable or normal wear items including but not limited to; flame guides, grates, coal bars, afterburner hoods, fire brick, gaskets. Additional exclusions for corn stoves are burnpot housing weldment, burnpot grate weldment (pellet or corn), burnpot front plate (pellet or corn), burnpot front plate lock, corn auger extension, ceramic insert, and ceramic insert plate. Additional or unusual utility bills incurred due to any malfunction or defect in equipment and the labor cost of gaining access to or removal of a unit that requires special tools or equipment are not covered. Maintenance needed to keep the stove in "good operating condition" is not covered. This includes, but is not limited to, cleaning, adjustment of customer controls and customer education. Labor, materials, expenses and/or equipment needed to comply with law and/or regulations set forth by any governmental agencies are not covered.

This Warranty provides specific legal rights and the consumer may have other rights that vary from state to state.

In the event of change in ownership, the remaining portion of this warranty may be transferred to the new owner by sending the new owner information and a transfer fee of \$25.00 US to Harman Home Heating.

PLEASE READ THE LITERATURE BY THE MANUFACTURER FOR THE VARIOUS ACCESSORY DEVICES. THE MANUFACTURER WARRANTS THESE ACCESSORY DEVICES, NOT HARMAN HOME HEATING OR THEIR WARRANTY ADMINISTRATOR. FURTHERMORE, THESE ACCESSORY DEVICES MUST BE INSTALLED AND USED ACCORDING TO THE RECOMMENDATIONS OF THE MANUFACTURER.

REMEDIES - The remedies set forth herein are exclusive and the liability of seller with respect to any contract or sale or anything done in connection therewith, whether in Contract, in tort, under any warranty, or otherwise, shall not, except as herein expressly provided, exceed the price of the equipment or part of which such liability is based.

CLARIFY - The above represents the complete warranty, which is given in connection with stoves, manufactured by Harman Home Heating. No other commitments, verbal or otherwise, shall apply except by a written addendum to this warranty.