

# Installation & Operating Manual

## P61A-2 Pellet Stove Owners Manual

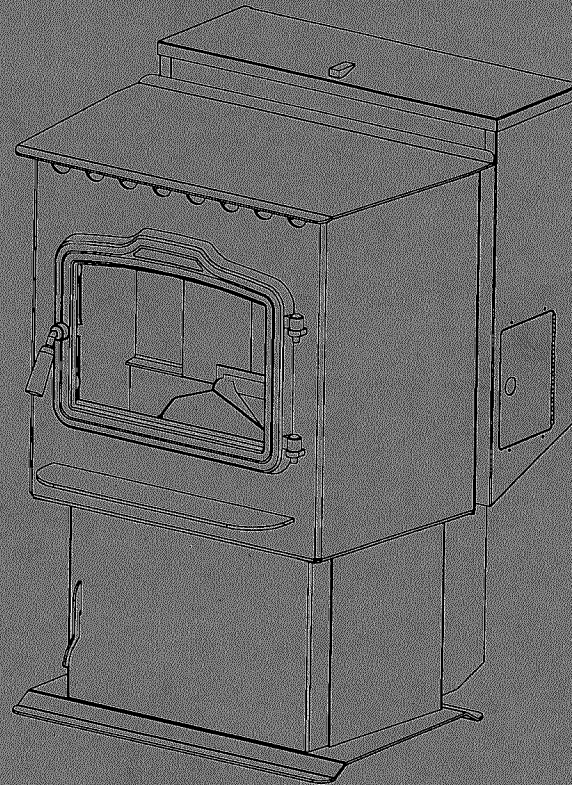

Safety Testing by  
Intertek Testing Services:  
ASTME1509  
Mobile Home Approved

*"Ce manuel est disponible en Français sur demande"*

R4

### SAFETY NOTICE

PLEASE READ THIS ENTIRE MANUAL BEFORE YOU INSTALL AND USE YOUR NEW ROOM HEATER. FAILURE TO FOLLOW INSTRUCTIONS MAY RESULT IN PROPERTY DAMAGE, BODILY INJURY, OR EVEN DEATH.

FOR USE IN THE U.S. AND CANADA. SUITABLE FOR INSTALLATION IN MOBILE HOMES

IF THIS HARMAN STOVE IS NOT PROPERLY INSTALLED, A HOUSEFIRE MAY RESULT. FOR YOUR SAFETY, FOLLOW INSTALLATION DIRECTIONS.

CONTACT LOCAL BUILDING OR FIRE OFFICIALS ABOUT RESTRICTIONS AND INSTALLATION INSPECTION REQUIREMENTS IN YOUR AREA.

CONTACT YOUR LOCAL AUTHORITY (SUCH AS MUNICIPAL BUILDING DEPARTMENT, FIRE DEPARTMENT, FIRE PREVENTION BUREAU, ETC.) TO DETERMINE THE NEED FOR A PERMIT.

CETTE GUIDE D'UTILISATION EST DISPONIBLE EN FRANCAIS. CHEZ VOTRE CONCESSIONNAIRE DE HARMAN STOVE COMPANY.

**SAVE THESE INSTRUCTIONS.**

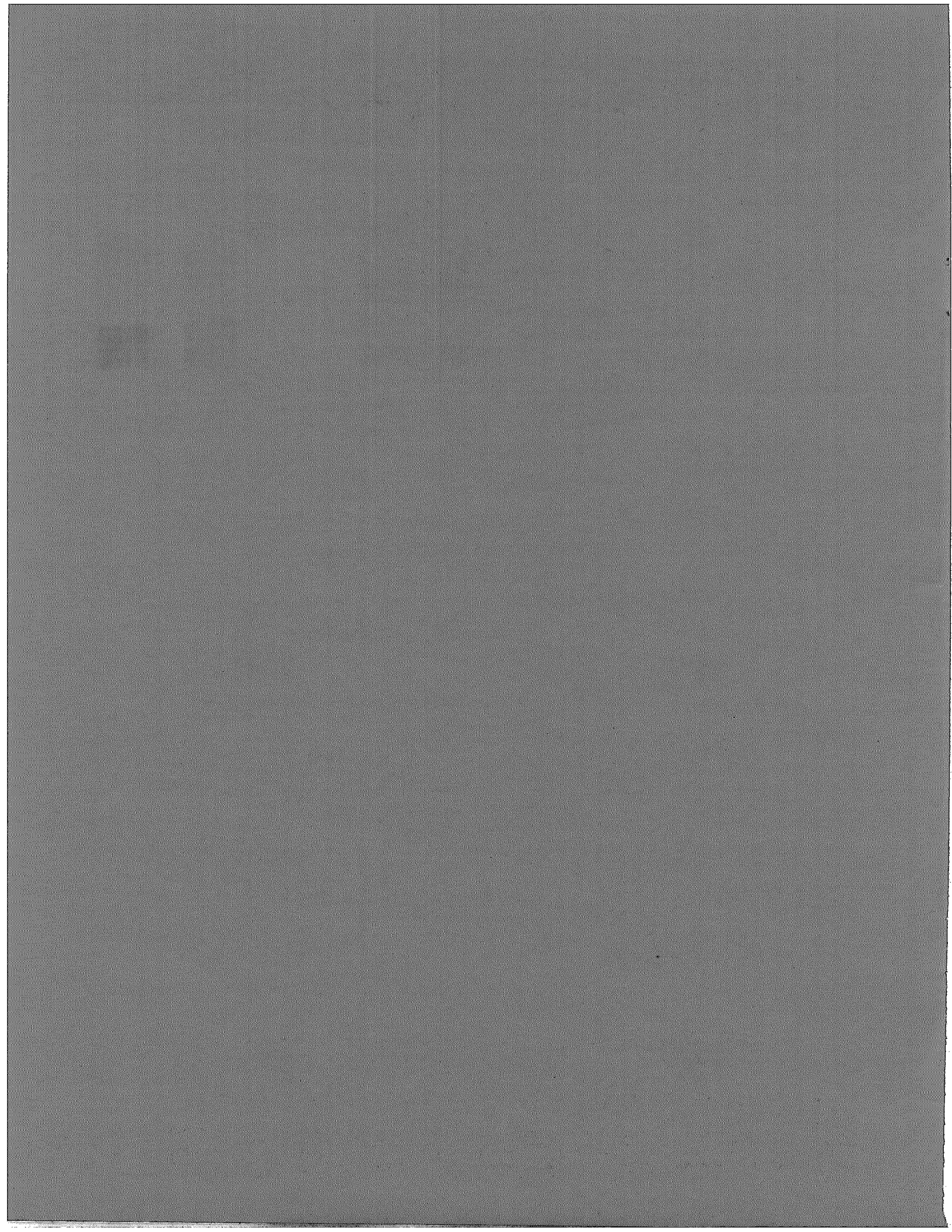



WVN 04433

TESTED TO: UL 1482 ASTM E1509  
OREGON 814-23-900

ULC-S627

WH-PN 025

TEST DATE: MARCH 1998

MINIMUM CLEARANCES  
TO COMBUSTIBLES:

SIDEWALL TO STOVE

BACKWALL TO STOVE

CEILING TO STOVE TOP

STOVE CORNER TO DIAGONAL WALL

PREVENT HOUSE FIRES, OPERATE WITH VIEWING & ASH DOOR  
CLOSED.

UNIT MUST BE PLACED ON A NON-COMBUSTIBLE FLOOR PROTECTOR  
EXTENDING 6" TO THE FRONT, 8" TO SIDES AND 1" TO REAR.

EXHAUST TYPE: LISTED TYPE L OR PL VENT INSTALLED TO VENT  
MANUFACTURER'S INSTRUCTIONS AND LOCAL BUILDING CODES.

ELECTRICAL RATING: 5 AMPS, 120 VOLTS, 60 HERTZ

FUEL: PELLETIZED OR BIOMASS

INSTALL AND USE ONLY IN ACCORDANCE WITH MANUFACTURER'S  
INSTALLATION AND OPERATING INSTRUCTIONS. CONTACT LOCAL  
BUILDING OR FIRE OFFICIALS ABOUT RESTRICTIONS & INSTALLATION  
INSPECTION IN YOUR AREA.

EPA EXEMPT PER 40 CFR 60.534, METHOD 28a.

APPROVED FOR USE IN MOBILE HOMES.

INPUT RATING: .75 TO 7.5 LBS PER HOUR.

DO NOT CONNECT THIS UNIT TO A CHIMNEY SERVING  
ANOTHER APPLIANCE

**LISTED PELLET FUEL BURNING ROOM HEATER  
MODEL: P-61-2**

WHI

DO NOT REMOVE THIS LABEL.  
NE PAS ENLEVER CETTE ÉTIQUETTE

INSTALL WITH MINIMUM  
CLEARANCES TO WALLS  
AS SHOWN

CORNER INSTALLATION 9"  
WITH OR 13" WITHOUT  
SIDESHIELDS

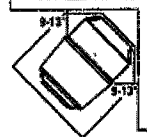

SIDEWALL-BACKWALL  
INSTALLATION WITH  
SIDESHIELDS

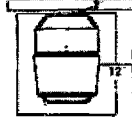

FLOOR PROTECTOR  
MINIMUM SIZE

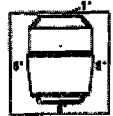

SIDEWALL-BACKWALL  
INSTALLATION WITHOUT  
SIDESHIELDS

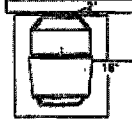

MANUFACTURED BY:  
HARMAN STOVE COMPANY  
352 MOUNTAIN HOUSE ROAD  
HALIFAX, PA 17032  
MADE IN USA



**APPAREIL DE CHAUFFAGE CATALOGUÉ DE  
MODÈLE POUR BRÛLER DES BOULETTES COMBUSTIBLES.  
MODÈLE: "P61-2"**

ESPACES LIBRES MINIMUM  
DES MATÉRIEAUX COMBUSTIBLES:

DU MUR DE CÔTÉ AU POÊLE

DU MUR ARRIÈRE AU POÊLE

DU PLAFOND AU DESSUS DU POÊLE

DU COIN DU POÊLE AU MUR DIAGONAL

SANS LES  
PROTECTEURS  
DE CÔTÉ

18"

2"

20"

13"

AVEC LES  
PROTECTEURS  
DE CÔTÉ

12"

2"

20"

9"

PRÉVENIR LES FEUX DE MAISONS. OPÉRER SEULEMENT AVEC LA  
PORTE D'OUVERTURE ET LA PORTE DES CENTRES FERMÉES.  
L'APPAREIL DOIT ÊTRE PLACÉ SUR UN PLANCHER PROTECTEUR  
INCOMBUSTIBLE. CELUI-CI S'ÉTENDANT DE 6" EN AVANT, DE 6" DES  
CÔTÉS ET 1" DE L'ARRIÈRE.

SORTE D'ÉCHAPPEMENT: VENTILATEUR DE TYPE L OU PL INSTALLÉ  
SELON LES INSTRUCTIONS DU FABRICANT ET SELON LES CODES  
LOCAUX DE LA CONSTRUCTION.

PUISSANCE ÉLECTRIQUE: 3 AMPS, 120 VOLTES, 60 HERTZ  
COMBUSTIBLE: DE BOULETTES COMBUSTIBLES OU BIOMASSES.

INSTALLER ET UTILISER SELON LES INSTRUCTIONS D'INSTALLATION  
ET D'OPÉRATION DE FABRICANT. CONTACTER LE BUREAU DE LA  
CONSTRUCTION OU LE BUREAU DES POMPIERS AU SUJET DES  
RESTRICTIONS ET DES INSPECTIONS D'INSTALLATION DANS VOTRE  
VOISINAGE.

EXEMPTION EPA PAR 40 CFR 60.534, DE METHODE 28a

APPROUVÉ POUR L'USAGE DANS LES MAISONS MOBILES

PUISSANCE ESTIMÉE: .75 À 7.5 LBS PAR HEURE.

INSTALLER AVEC LES DIS-  
TANCES MINIMUM DE SECURITÉ  
COMME INDICÉ.

INSTALLATION EN ANGLE 9° AVEC  
OU 13° SANS PROTECTIONS  
MURALES

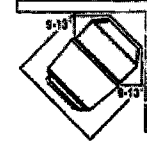

DISTANCES AUX MURS  
LATERAL ET ARRIERE AVEC  
PROTECTIONS MURALES

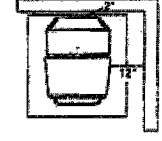
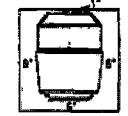
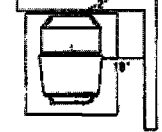

TABLE MINIMALE  
DE LA PROTECTION DE SOL



DISTANCES AUX MURS  
LATERAL ET ARRIERE SANS  
PROTECTIONS MURALES



NE PAS CONNECTER CET APPAREIL À  
UNE CHEMINÉE SERVANT UN AUTRE  
APPAREIL.

# Table of Contents

Assembly & Installation	4
Installation	6
Venting	7
Automatic Operation	13
ESP Control	17
Maintenance	19
Trouble Shooting	22
Feeder Parts	23
Specifications	23
Options	24
Wiring Diagram	26
Parts List	27
Warranty	28

Please read this entire manual before you install and use your new room heater. Failure to follow instructions may result in property damage, bodily injury, or even death.

**SUITABLE FOR MOBILE HOME INSTALLATIONS.**

**Harman Stove Company**  
352 Mountain House Road  
Halifax, PA 17032

# Assembly and Installation

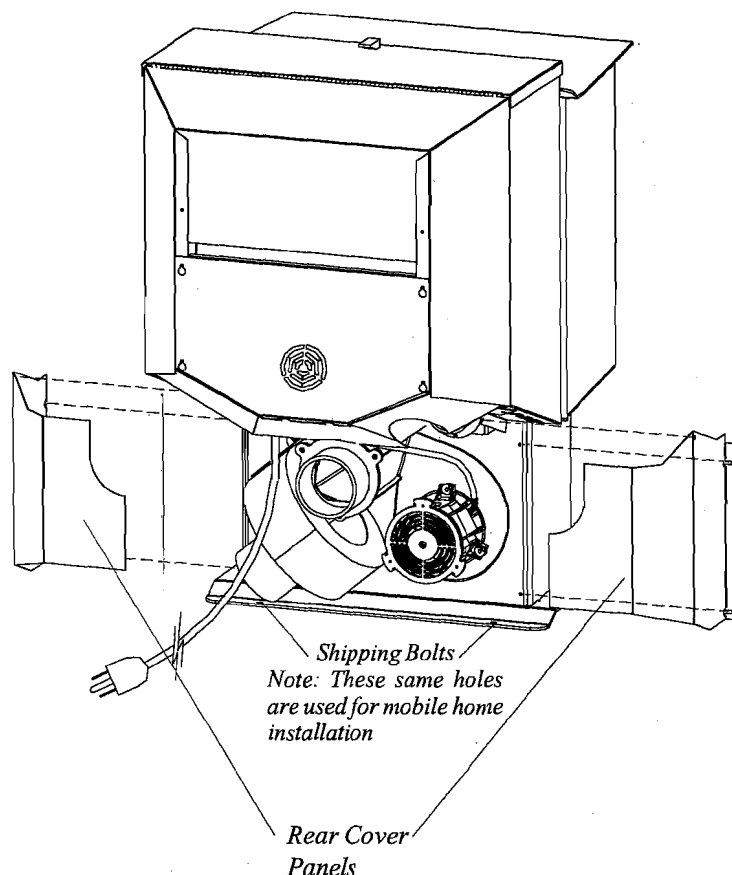

## Unpacking

The P61 is bolted to the skid to prevent movement during shipping.

To free the stove from the skid you must remove the hold-down bolts in the rear of the pedestal base.

## Installing rear cover panels

The rear cover panels are removed from the stove to make it easier to get at the hold-down bolts.

The rear cover panels are packed inside the hopper and should be installed on the stove as shown. It is recommended that the rear covers are installed after the unit is in place and the vent pipe is installed.

## Firebrick

Install the firebrick vertically on the angle above the burnpot.

## Flame Guide

Install the cast iron flame guide on top of the burnpot and make sure it is fully seated against the auger opening. The bottom of the flame guide is marked 38+.

**DO NOT INSTALL A FLUE DAMPER IN THE EXHAUST VENTING SYSTEM OF THIS UNIT.**

**DO NOT CONNECT THIS UNIT TO A CHIMNEY FLUE SERVING ANOTHER APPLIANCE.**

**INSTALL VENT AT CLEARANCES SPECIFIED BY THE MANUFACTURER**

**Mobile home installation should be done in accordance with the Manufactured Home and Safety Standard (HUD), CFR 3280, Part 24.**

## WARNING

**DO NOT INSTALL IN SLEEPING ROOM**

## CAUTION

**THE STRUCTURAL INTEGRITY OF THE MOBILE HOME FLOOR, WALL, AND CEILING/ROOF MUST BE MAINTAINED.**

## CAUTION

**KEEP COMBUSTIBLE MATERIALS (SUCH AS GRASS, LEAVES, ETC.) AT LEAST 3 FEET AWAY FROM THE FLUE OUTLET ON THE OUTSIDE OF THE BUILDING.**

# Door Assembly/Installation Tips

## Bottom Glass Retainer Clip Instructions

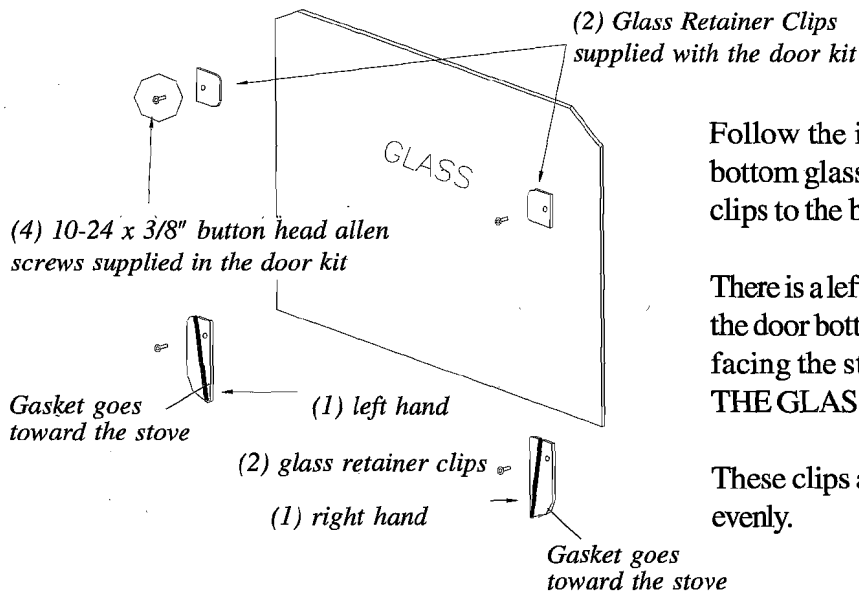

Follow the instructions in the door kit except for the bottom glass retainers. Install the special glass retainer clips to the bottom of the door.

There is a left and right retainer clip with a radius to match the door bottom. The fiber glass rope on the clip must be facing the stove body when installed, **NOT FACING THE GLASS!!**

These clips are designed to direct the air wash air more evenly.

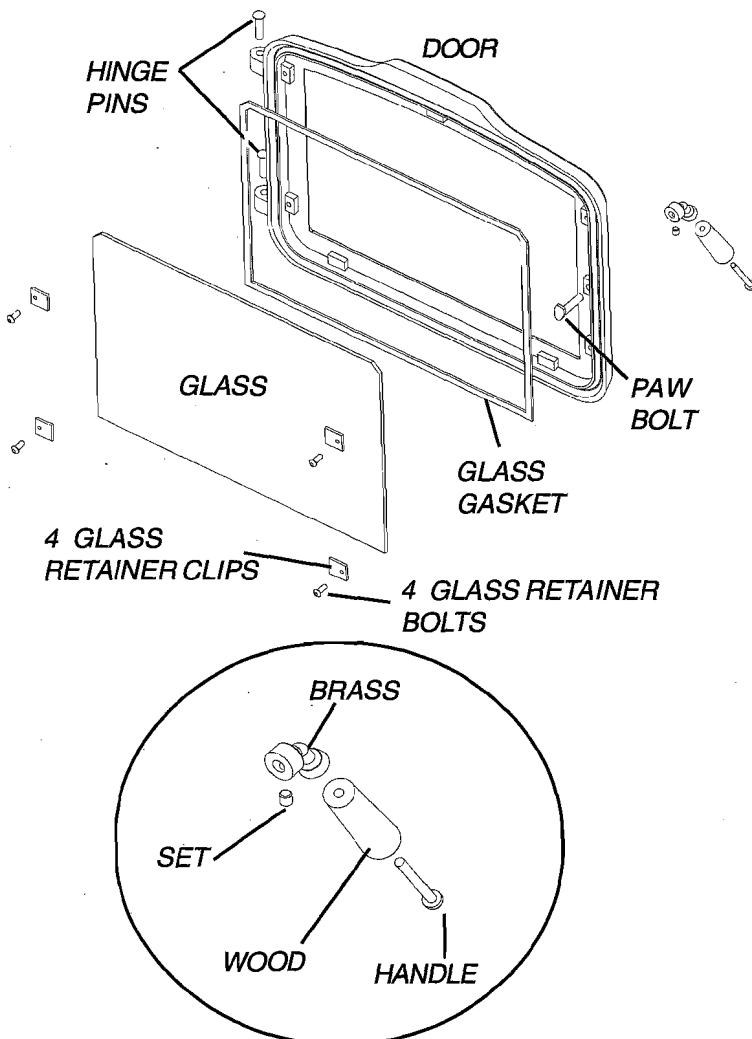

### Assembling the door

Referring to the diagram, note how the various components of the door system fit together. Lay the door face down on a soft surface.

Clean the glass and gold door using a nonabrasive cleaner. Install the glass gasket around the outer edge of the front face of the door glass carefully to insure proper sealing. Set the glass pane gently onto the door. Install the hold-down clips and tighten with bolts as shown.

Install door on stove with hinge pins.

Install door handle as shown on the diagram. **NOTE:** With the flat surface of the paw bolt to the inside of the door.

Turn the paw bolt "in" for approx. (17) turns.

Turn the brass elbow onto the paw bolt approx. (5) turns.

Align the set screw with the flat spot on the paw and tighten.

After attaching the door handle, close and latch the door by turning the handle to the six o'clock position. Does the door rope compress? If not, loosen the set screw, turn the paw bolt one more turn into the door. Repeat as required to achieve a tight door fit.

**NOTE:** Remember to thoroughly clean the glass and the gold door frame before lighting the stove for the first time.

Fig. 2

# Installation

## Installing

Place the stove on a noncombustible floor protector that extends 6 inches to the front, 6 inches to the sides and 1 inch to the rear of the stove. The minimum floor protector material is 24 gauge sheet metal.

Place the stove away from combustible walls at least as far as shown in figures 3,4 and 5. Please note the difference in side wall clearance with and without side shields.

Note that the clearances shown are minimum for safety but do not leave much room for access when cleaning or servicing. Please take this into account when placing the stove.

Connect the power cord to a 120 V.A.C. 60Hz grounded receptacle. (A surge protector is recommended to protect the circuit board).

Prior to installing the flue pipe, connect a draft meter to the stove as shown in fig. 6. (The draft meter must have a minimum range of 0-.5). However, prior to taking the draft reading be sure all doors and windows in the home are closed. Record the draft reading \_\_\_\_\_. If this reading is more than .05" lower than the unconnected reading, check for possible restrictions or the need for outside air (see page 8).

## Mobile Home Installation

When installing this unit in a mobile home several requirements must be followed:

1. The unit must be bolted to the floor. This can be done with 1/4" lag screws through the 2 holes in the base plate.

2. The unit must also be connected for the outside air. See page 8.

3. Floor protection and clearances must be followed as shown.

4. Unit must be grounded to the metal frame of the mobile home.

**CAUTION: This appliance must be vented to the outside.**

Due to high temperatures, the stove should be placed out of traffic and away from furniture and draperies.

Children and adults should be alerted to the hazards of high surface temperatures and should stay away to avoid burn to skin and/or clothing.

Young children should be carefully supervised when they are in the same room as the stove.

Clothing and other flammable materials should not be placed on or near this unit.

Installation and repair of this Harman Stove should be done by a qualified service person. The appliance should be inspected before use and at least annually by a qualified service person. More frequent cleaning will be required. It is imperative that control compartments, burners, and circulating air passageways of the stove be kept clean.

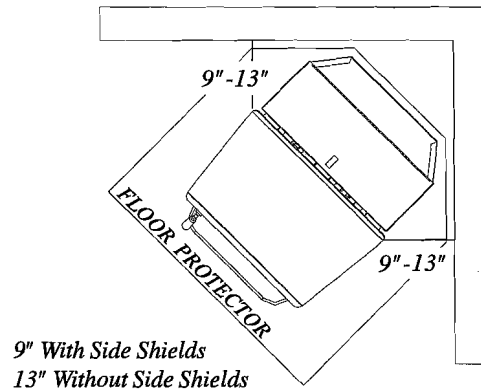

Fig. 3

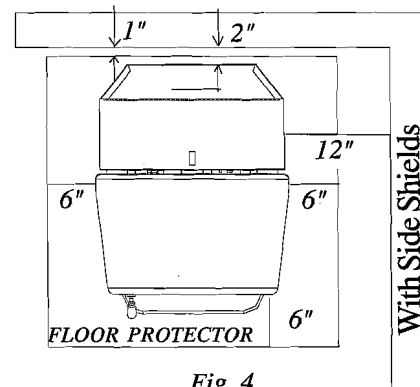

Fig. 4

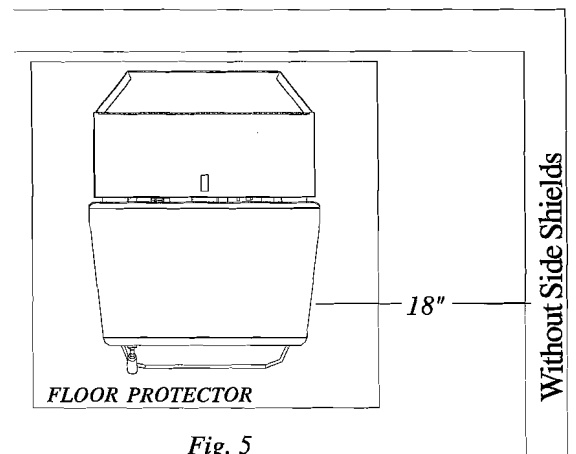

Fig. 5

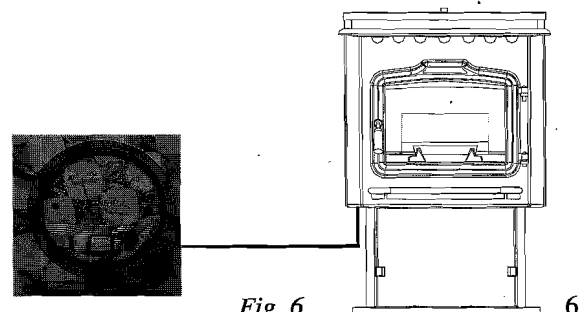

Fig. 6

# Venting

## Requirements for Terminating the Venting

**WARNING:** Venting terminals must not be recessed into a wall or siding.

**NOTE:** Only PL vent pipe wall pass-throughs and fire stops should be used when venting through combustible materials.

**NOTE:** Always take into consideration the effect the prevailing wind direction or other wind currents will cause with flyash and /or smoke when placing the termination.

**In addition, the following must be observed:**

A. The clearance above grade must be a minimum of 18".<sup>1</sup>

B. The clearance to a window or door that may be opened must be a minimum of 48" to the side, 48" below the window/door, and 12" above the window/door.<sup>1</sup>

( with outside air installed, 18" )

C. A 12" clearance to a permanently closed window is recommended to prevent condensation on the window.

D. The vertical clearance to a ventilated soffit located above the terminal within a horizontal distance of 2 feet (60 cm) from the center-line of the terminal must be a minimum of 18".

E. The clearance to an unventilated soffit must be a minimum of 12".

F. The clearance to an outside corner is 11" from center of pipe.

G. The clearance to an inside corner is 12".

H. A vent must not be installed within 3 feet (90 cm) above a gas meter/regulator assembly when measured from the horizontal center-line of the regulator.<sup>1</sup>

I. The clearance to service regulator vent outlet must be a minimum of 6 feet.<sup>1</sup>

J. The clearance to a non-mechanical air supply inlet to the building or the combustion air inlet to any other appliance must be a minimum of 48".<sup>1</sup>

K. The clearance to a mechanical air supply inlet must be a minimum of 10 feet.<sup>1</sup>

(with outside air installed, 6 feet )

L. The clearance above a paved sidewalk or a paved driveway located on public property must be a minimum of 7 feet.<sup>1,2</sup>

M. The clearance under a veranda, porch, deck or balcony must be a minimum of 12 inches.<sup>1,3</sup>

**NOTE:** The clearance to vegetation and other exterior combustibles such as mulch is 36" as measured from the center of the outlet or cap. This 36" radius continues to grade or a minimum of 7 feet below the outlet.

<sup>1</sup>Certain Canadian and or Local codes or regulations may require different clearances.

<sup>2</sup>A vent shall not terminate directly above a sidewalk or paved driveway which is located between two single family dwellings and serves both dwellings.

<sup>3</sup>Only permitted if veranda, porch, deck, or balcony is fully open on a minimum of 2 sides beneath the floor.

**NOTE: Where passage through a wall, or partition of combustible construction is desired, the installation shall conform to CAN/CSA-B365. (if in Canada)**

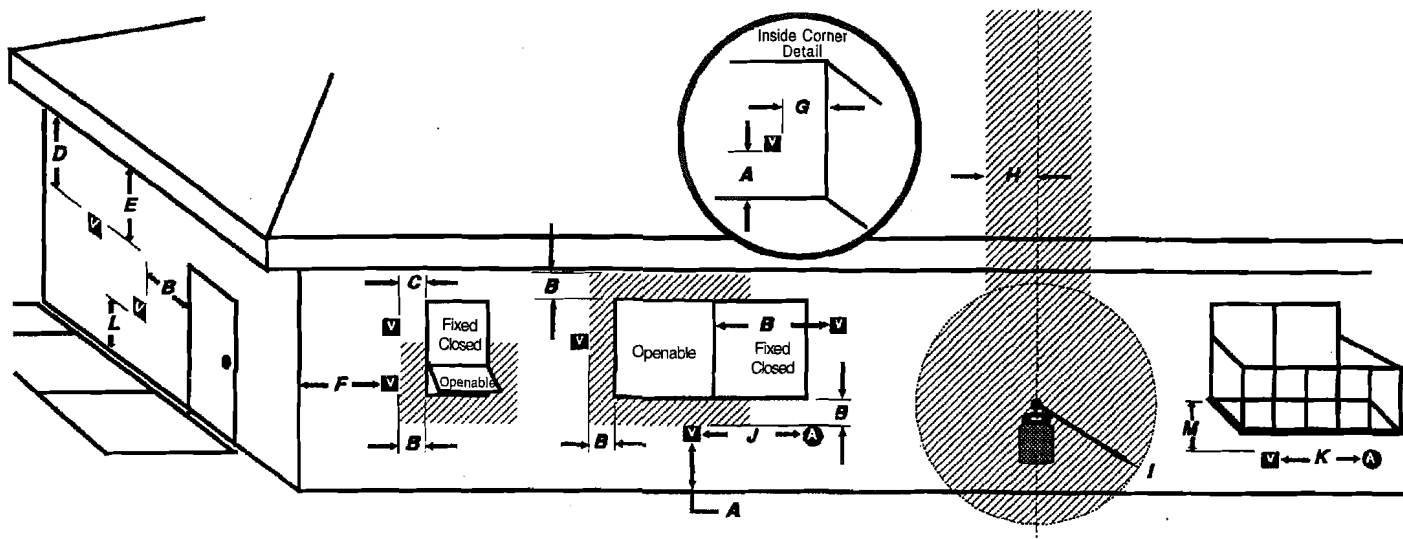

**V** = Vent terminal

**A** = Air supply inlet

 = Area where terminal is not permitted



# Venting

## IMPORTANT NOTICE

Pellet Vent Pipe or PL Vent Pipe Must be used.

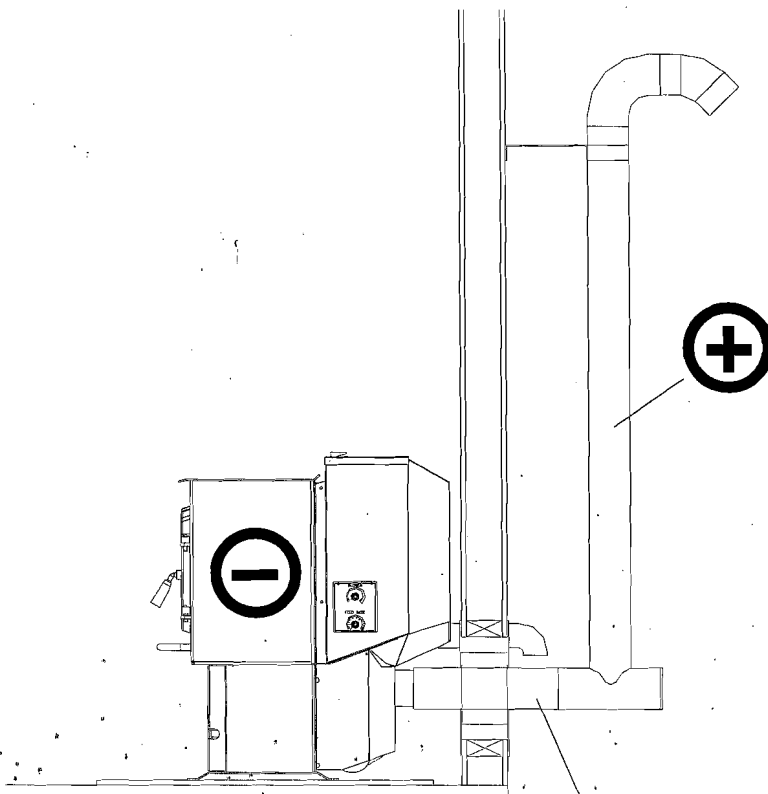

Fig. 7

⊕ = Positive static pressure  
⊖ = Negative static pressure

## Venting

A combustion blower is used to extract the combustion gases from the firebox. This causes a negative pressure in the firebox and a positive pressure in the venting system as shown in fig. 7. The longer the vent pipe and more elbows used in the system, the greater the flow resistance. Because of these facts we recommend using as few elbows as possible and 15 feet or less of vent pipe. The maximum horizontal run should not exceed 48". If more than 15 feet of pipe is needed, the diameter should be increased from 3" to 4" because a larger pipe causes less flow resistance. **Be sure to use approved pellet vent pipe wall and ceiling pass through fittings to go through combustible walls and ceilings.** Be sure to use a starting collar to attach the venting system to the stove. **The starting collar must be sealed to the stove with high temp silicone caulking.**

## Vent Pipe

Pellet venting pipe ( also known as PL vent ) is constructed of two layers with air space between the layers. This air space acts as an insulator and reduces the outside surface temperature to allow a clearance to combustibles of only 3 inches. The sections of pipe lock together to form an air tight seal in most cases; however, in some cases a perfect seal is not achieved. For this reason and the fact that the P61 operates with a positive vent pressure we specify that the joints also be sealed with clear silicone.

## Outside Air

Outside air is optional except in mobile homes and where building codes require. The benefit of outside air is mainly noticed in small very tight houses.

To install outside air use 2 3/8" I.D. flex pipe part number 3-40-08543. There is a break-away hole on the rear panel which must be removed before connecting the flex pipe. The pipe should be run outside and terminate 3 feet or more to the side or below the vent pipe outlet. Never terminate the outside air above the vent pipe outlet. The maximum length run of this pipe is 15 feet. If a longer run is needed the size must be increased to 3". Inlet cover part number 1-10-08542 should be used to keep birds, rodents etc.out of pipe.

## HRV

When installing in a house with a Heat Reclaiming Ventilation System (HRV) be sure the system is balanced and is not creating a negative pressure in the house. 8

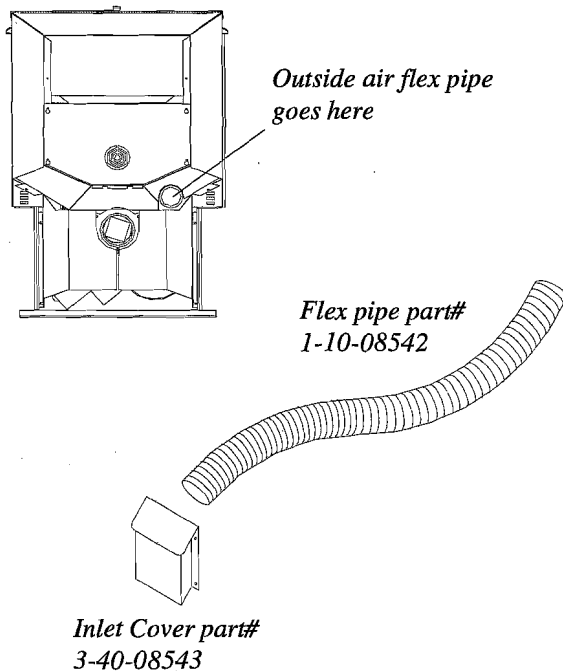

# Venting

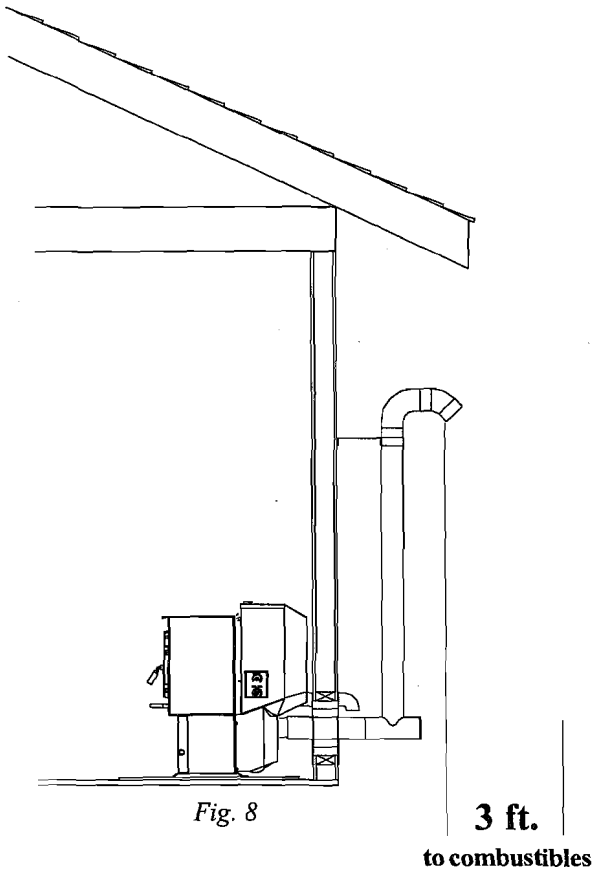

## #1 Preferred method

This method provides excellent venting for normal operation and allows the stove to be installed closest to the wall. Two inches from the wall is safe; however, four inches allows better access to remove the rear panel. The vertical portion of the vent should be three to five feet high. This vertical section will provide natural draft in the event of a power failure.

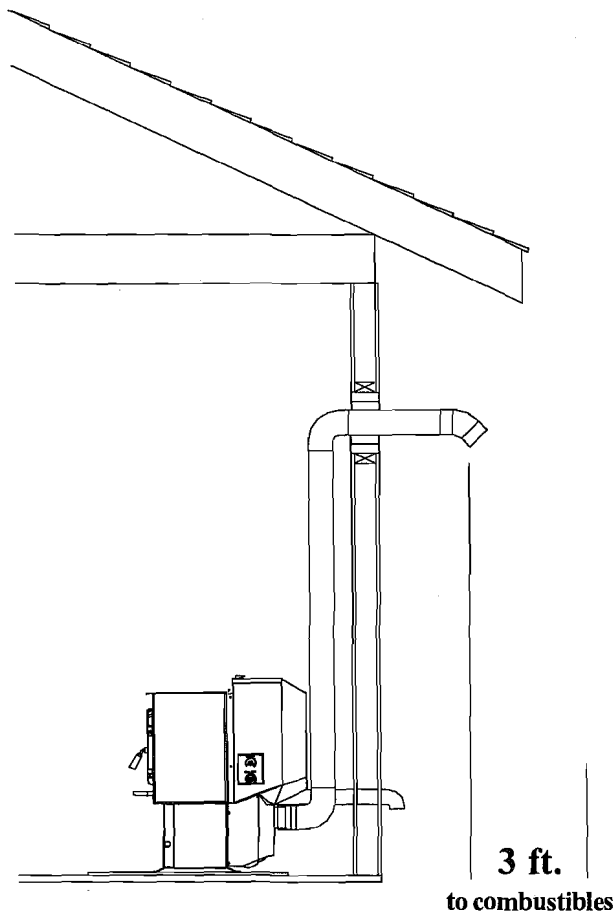

## #2 Preferred method

This method also provides excellent venting for normal operation but requires the stove to be installed farther from the wall. The vertical portion of the vent should be three to five feet high and at least three inches from a combustible wall. This vertical section will provide natural draft in the event of a power failure.

If the stove is installed below grade be sure the vent termination should be at least 1 foot above grade.

### CAUTION

Keep combustible materials (such as grass, leaves, etc.) at least 3 feet away from the flue outlet on the outside of the building.

## #4 Installing into an existing chimney ( US only )

This method provides excellent venting for normal operation. This method also provides natural draft in the event of a power failure. If the chimney condition is questionable you may want to install a liner as in method #7.

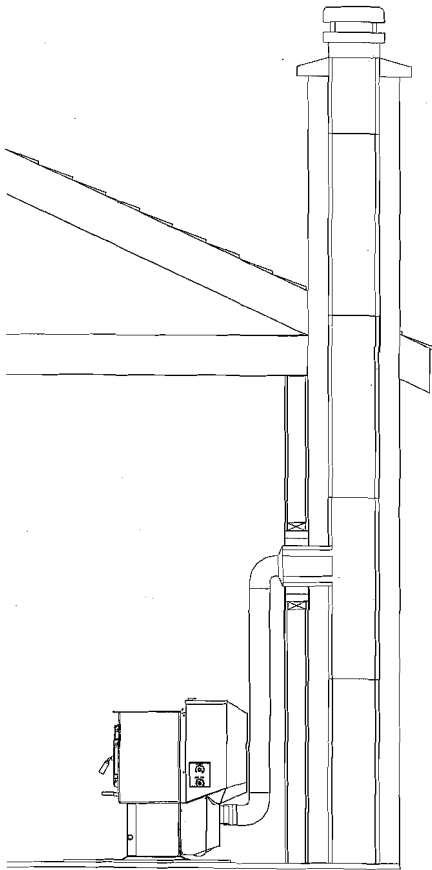

Fig. 10

## #5 Installing into an existing fireplace chimney ( US only )

This method provides excellent venting for normal operation. This method also provides natural draft in the event of a power failure.

The damper area must be sealed with a steel plate or fiberglass. A cap should be installed on the chimney to keep out rain. If the chimney condition is questionable you may want to install a liner all the way to the top as in method #6.

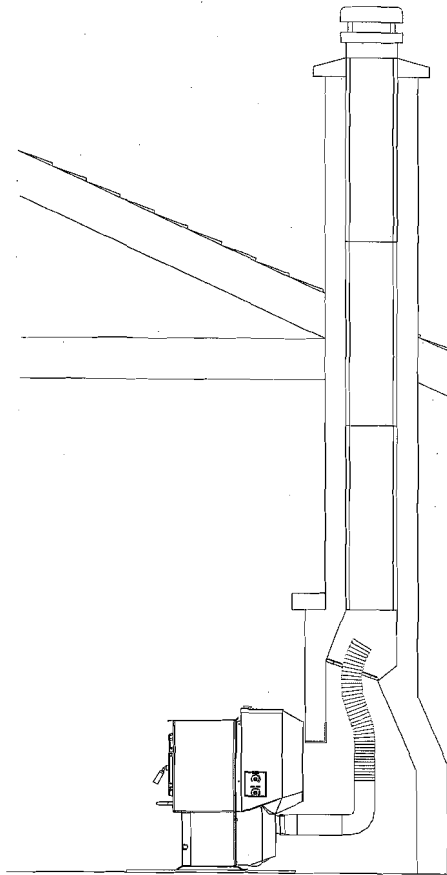

Fig. 11

# Venting

## #6 Installing into an existing fireplace chimney ( US and Canada )

This method provides excellent venting for normal operation. This method also provides natural draft in the event of a power failure.

In Canada and some places in the US it is required that the vent pipe extend all the way to the top of the chimney.

In this method a cap should also be installed on the chimney to keep out rain. Be sure to use approved pellet vent pipe fittings. Seal pipe joints with silicone in addition to the sealing system used by the manufacturer. Pipe size should be increased to 4" using this method.

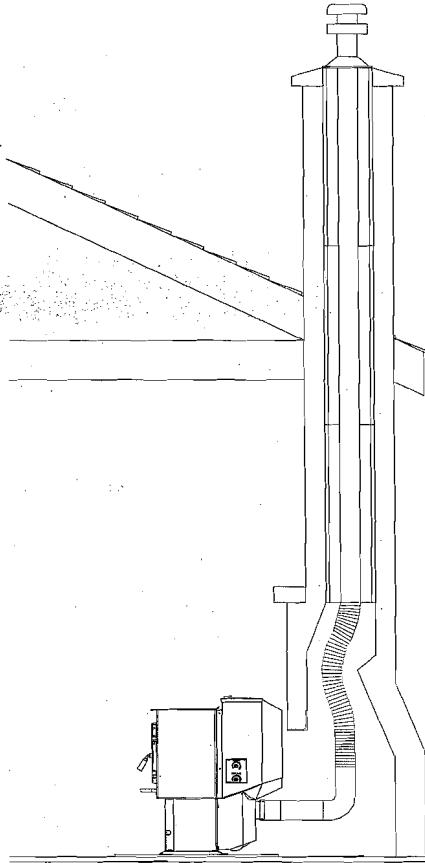

Fig. 12

## #7 Installing into an existing chimney ( US and Canada )

This method provides excellent venting for normal operation. This method also provides natural draft in the event of a power failure.

In Canada and some places in the US it is required that the vent pipe extend all the way to the top of the chimney. The pipe or liner inside the chimney should be 4" diameter.

In this method a cap should also be installed on the chimney to keep out rain. One disadvantage of this method is that it is harder to clean the vent pipe, therefore, there is a tendency not to do it as often as needed.

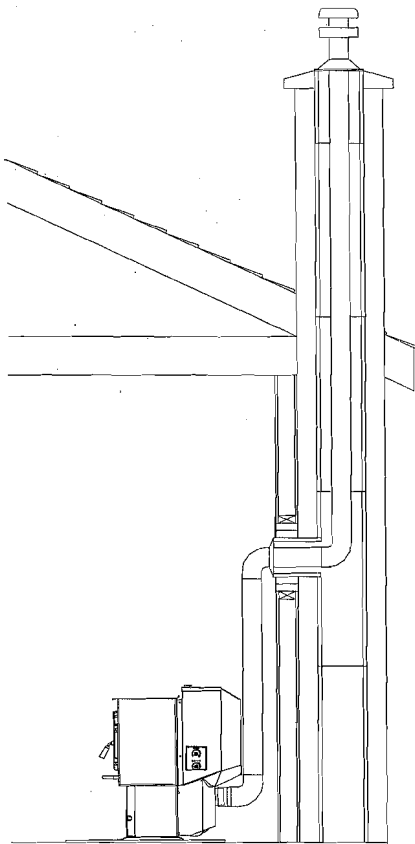

# Venting

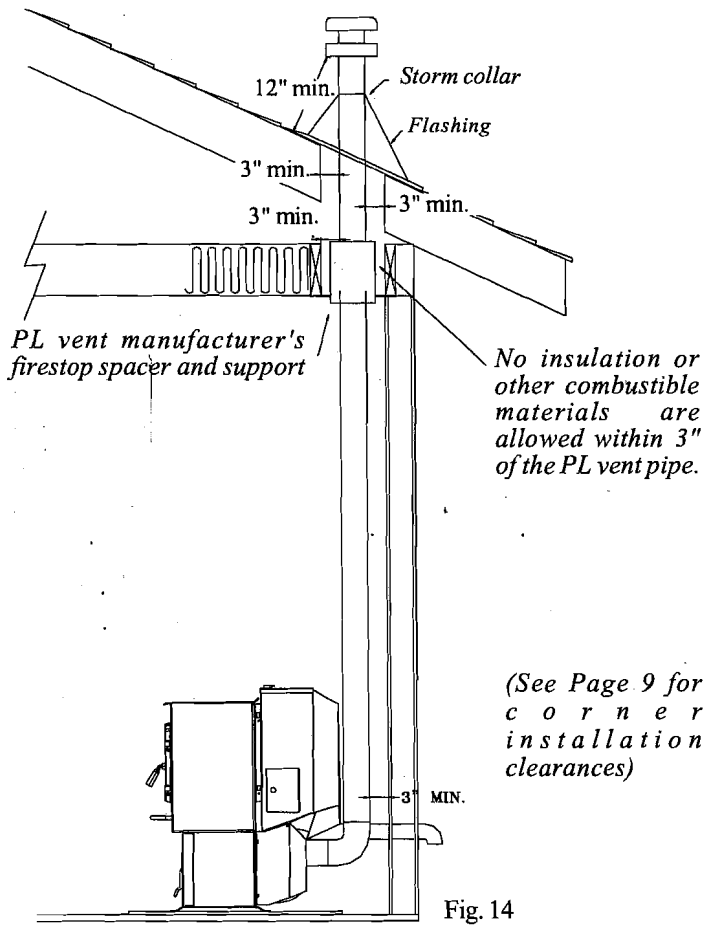

Fig. 14

## #8 Installing through the ceiling vent

Through the ceiling vent, follow PLvent manufacturers recommendations when using wall and ceiling pass through.

## Minimum flue vent configuration

It is recommended that outside air be installed with this venting configuration.

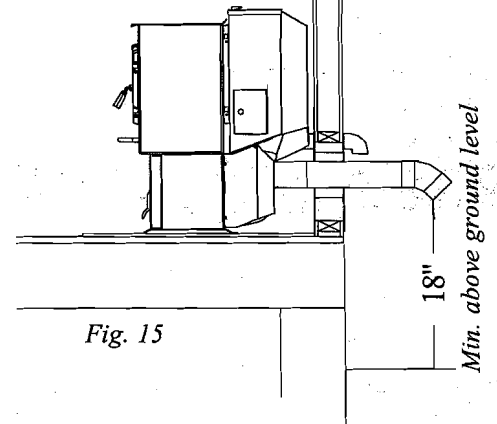

Fig. 15

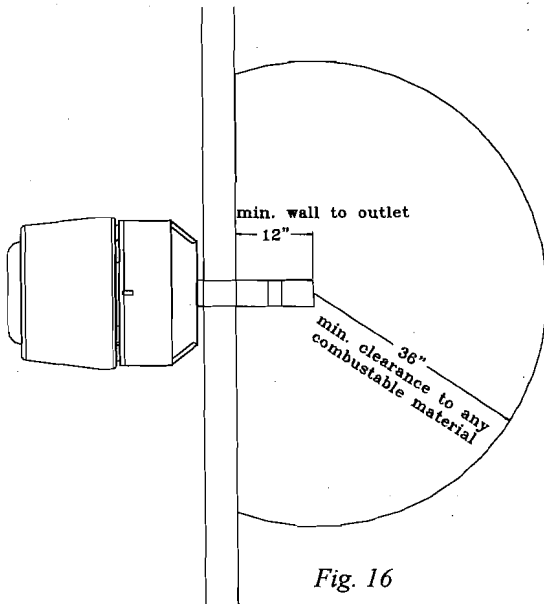
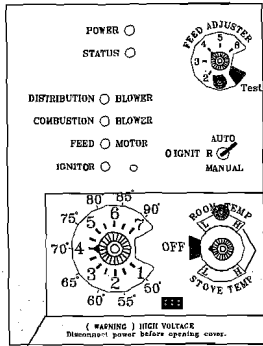

Fig. 16

# P61A-2 AUTOMATIC IGNITION/OPERATION



The P61A pellet stove is more than just automatic ignition, it is also automatic temperature control. The automatic system will allow the fire size to be adjusted to match the heating needs and even put the fire out if necessary. If heat is needed after the fire is out, the P61A will automatically re-ignite and adjust the fire size to match the heating need. The totally automatic room sensor mode is recommended because of its efficiency.

The unit can be switched between "AUTO" and "MANUAL" at any time during operation.

## Ignitor switch to "AUTO"

### Room Temperature Mode

In "Room Temp Mode" heat output is controlled automatically by the Room Sensing Probe. When the Room Sensing Probe calls for heat, the stove will increase output. When the Room Sensing Probe is getting close to the set temperature, the stove will begin to level off output and keep the fire burning at just the right temperature to maintain that setting.

High output is determined by the feed rate setting. This setting, generally on #4, can be increased if higher burn rates are necessary. The unit's maximum burn rate should not create less than 1" of ash on the burn pot front edge. See Fig.2. Overfeeding is not a safety concern, but fuel may be wasted if unburned pellets fall into the ash pan.

In "Room Temp Mode" a constant fuel consumption rate is sacrificed for exact room temperature. Therefore, as it gets colder more pellets will be burned automatically.

The distribution blower speed will vary according to the position of the mode selector pointer, and fire size.

## Ignitor switch to "AUTO"

### Stove Temperature Mode

This allows for automatic ignition upon start-up only. The unit can then be set at any desired setting. The heat output and fuel consumption will remain constant regardless of room temperature. The unit's maximum feed rate should not create less than 1" of ash on the burn pot front edge. See Fig 2.

The unit's low burn or maintenance setting is as low as it will go. It will not go out unless it runs out of fuel or is turned off.

## Shut-Down Procedure

To kill the fire or stop burning the stove, turn the Mode Selector to "OFF". This will cause the fire to diminish and burn out. When the fire burns out and the stove cools down everything will stop.

If you pull the plug to shut down the stove, all motors will stop. This may cause incomplete combustion and smoke in the firebox. If the load door is opened the smoke may escape.

The best way to shut down the stove is simply let it run out of pellets, then the stove will shut down automatically.

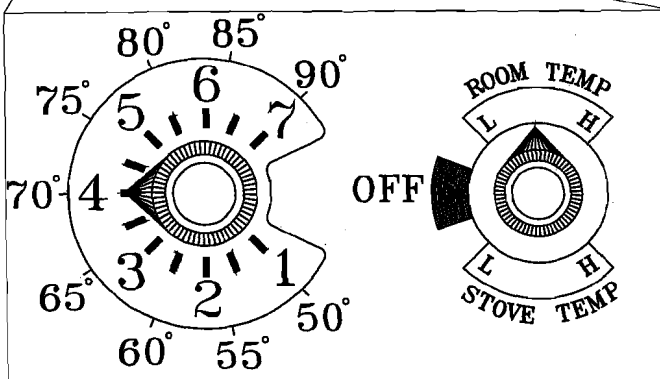

**Room Temperature Mode:** This setting will produce a room temperature of 70 degrees with the distribution blower at medium speed.

### Stove Temperature Mode

*This setting will produce medium heat with the distribution blower on "low".*

*This setting will produce continuous maximum heat output with the distribution blower at full speed.*

# P61A-2 AUTOMATIC START UP

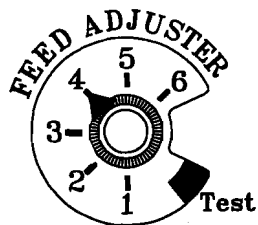

Fig. 17

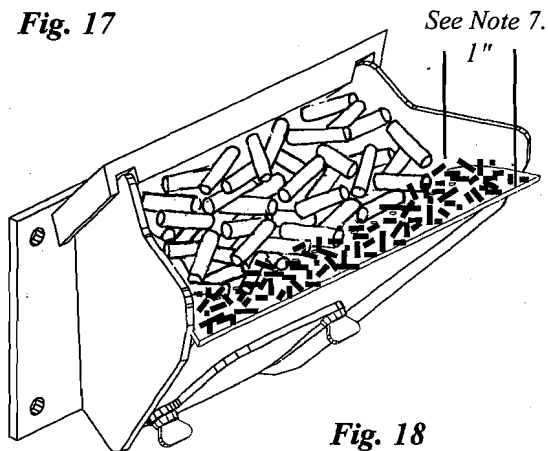

Fig. 18

1. Fines are small pieces of broken pellets (sawdust). Fines do not flow easily and often build up on the hopper funnel bottom angles. These fines can be pushed into the feeder opening and then fill the hopper with pellets. As the system works, they will be burned.

2. The "TEST" cycle will operate the feeder motor for exactly one minute. Turning to "TEST" again and again may purge too much fuel into the burn pot causing excessive smoke on start-up.

3. The firebox low pressure switch will not allow the auger motor or the igniter element to operate if the view door or the ash pan door are open.

4. Adjust Feed Rate. If this is your first fire or you are trying different pellets, set the feed adjuster to #4, Fig. 17. This is a conservative number and will probably need to be increased. After you know a feed rate setting that works well, use that setting. Remember, if your feed rate is too high you may waste fuel.

5. This is usually a weekly maintenance procedure. Cleaning the burn pot with the scraper with a small amount of new fuel in the bottom is not a problem. First, scrape the ashes on the front of the burn pot into the ash pan. Then scrape the holed surface downward into the burn pot. When the stove is ignited these scrapings will be pushed out by the feeder.

6. The ash pan can hold the ashes from approximately 1 ton of premium fuel. This means the ashes will only need to be emptied a few times a year.

7. Setting the feed adjuster # for maximum burn: With the unit burning in "AUTO", turn to "Stove Mode" and put the fan on "H". Set the Temperature Dial to #7. Allow the unit to burn for about 30 minutes and check ash on front of burn pot. Fig. 18. If the ash line is larger than 1", turn the feed adjuster from #3 to #4. Allow another 30 minutes of burn time and check again. If, at #6 setting, a 1" or less ash bed is not obtainable, it is not a problem. The 1" ash bed is only a maximum burn rate and at most normal settings the ash bed will be larger.

## Starting First Fire

### Ignitor Switch to "AUTO"(up position)

Make sure the unit is plugged into a 120 VAC, 60 HZ electrical source. The power light should be the only light lit.

#### NOTICE:

When power is given to the stove, the control board will blink a few times to indicate current version of control board.

1. Turn Mode Selector to "OFF".
2. Fill hopper with pellets.<sup>1</sup>
3. Clean burn pot with scraper, if necessary.<sup>5</sup>
4. If starting after an empty hopper, turn Feed Adjuster to "TEST" (for one 60 second cycle).<sup>2</sup> This will purge pellets into the auger tube and also allow you to check the motors for operation. **NOTE: The auger motor will not operate with the view door or ash pan door open.**<sup>3</sup>
5. Turn Feed Adjuster to #4.<sup>4</sup>
6. Flip the Ignitor Switch up into the "AUTO" position.
7. Turn the Temperature Dial to desired room temperature.
8. Turn Mode Selector to Room Temperature or Stove Temperature.
9. Fill hopper with pellets and remove ashes as required.<sup>6</sup>

#### Warning

**"NEVER USE GASOLINE, GASOLINE-TYPE LANTERN FUEL, KEROSENE, CHARCOAL LIGHTER FLUID, OR SIMILAR LIQUIDS TO START OR "FRESHEN UP" A FIRE IN THIS HEATER. KEEP ALL SUCH LIQUIDS WELL AWAY FROM THE HEATER WHILE IN USE".**

# P61A-2 MANUAL IGNITION/OPERATION

The P61A Pellet Stove is capable of manual operation. This also allows the operator to manually control operation during an emergency (i.e. ignitor failure, when using a 502H battery backup, or when using certain generators.)

The unit can be switched between "AUTO" and "MANUAL" at any time during operation.

**NOTE:** When starting the unit in the "AUTO" mode and switching to "MANUAL", the fire must be large enough to start the distribution blower. The starting of the blower is a signal that the start cycle is completed and the fire will not go out.

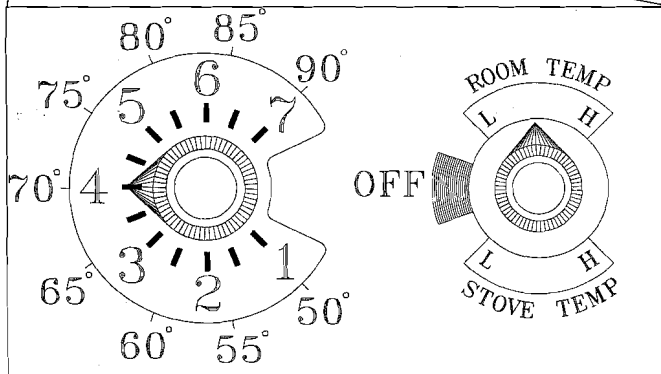
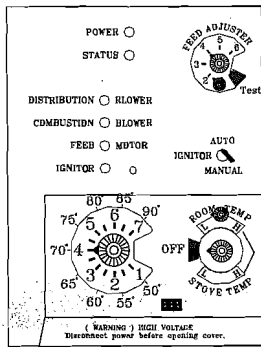

**Room Temperature Mode:** This setting will produce a room temperature of 70 degrees with the distribution blower at medium speed.

## Manual Stove Temperature Mode

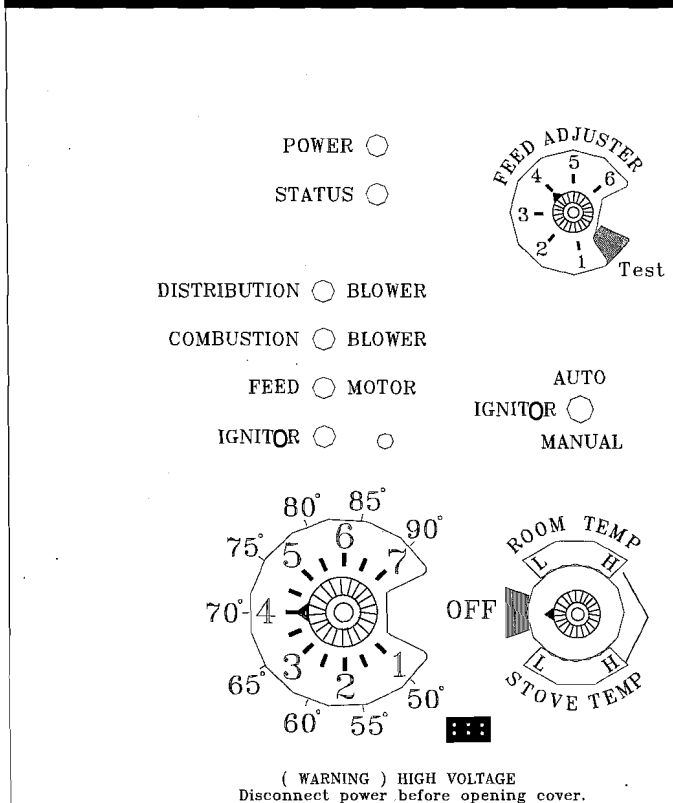

*This setting will produce a large viewing fire without a distribution blower operating.*

## Ignitor Switch to "MANUAL"

### Room Temperature Mode

The fire will have to be lit with starting gel and a match, or started automatically, see "Automatic Operation". Turn to "Manual" position when the fire is established.

The difference between "AUTO" Room Temperature Mode and "Manual" Room Temperature Mode is that the fire will not go out as the room temperature goes above the control board setting. The unit can only go to low burn and will remain there until it runs out of fuel or until more heat is needed and the feed rate increases. Feed rate adjustments and dial settings are the same as "AUTO" settings.

## Ignitor Switch to "MANUAL"

### Stove Temperature Mode

The advantage of this mode is to allow the operator to have a large viewing fire without blowing extra heat into the room.

During operation, with the temperature dial set at #5 or less, the distribution fan will not operate. A #5 on the temperature dial and a #5 on the feed adjuster is approximately 80% output. It is not necessary to operate the distribution blower below this point. Therefore, there can be a higher feed rate ( a larger viewing fire) without an excess of hot air blowing into the room.

An example of when to use the Manual Stove Temperature Mode is if you want to watch a large fire and the room is already up to temperature. The Stove Temperature Mode allows you to have a larger fire and a lower sound level, without the distribution blower.

**NOTE:** During the use of this mode, if you keep increasing the temperature dial setting to increase the fire size, the distribution blower will automatically come on when the ESP Temperature reaches 350° F, or 81 % output.



# P61A-2 MANUAL START UP

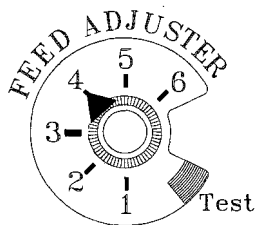

Fig. 19

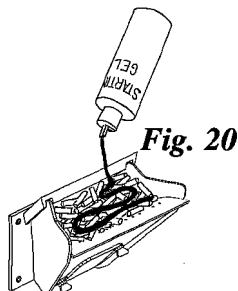

Fig. 20

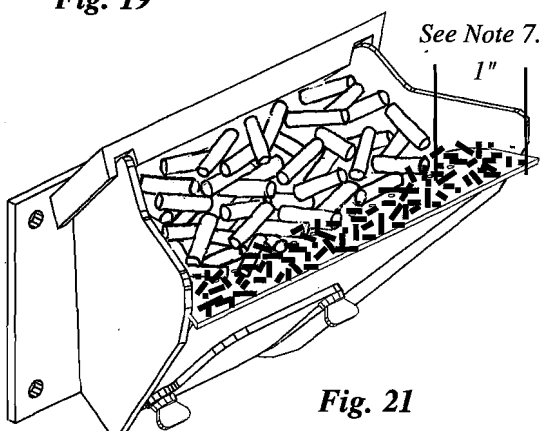

Fig. 21

1. Fines are small pieces of broken pellets (sawdust). Fines do not flow easily and often build up on the hopper funnel bottom angles. These fines can be pushed into the feeder opening and then fill the hopper with pellets. As the system works, they will be burned.

2. The "TEST" cycle will operate the feeder motor for exactly one minute. Turning to "TEST" again and again may purge too much fuel into the burn pot causing excessive smoke on start-up.

3. The firebox low pressure switch will not allow the auger motor or the igniter element to operate if the view door or the ash pan door are open.

4. Adjust Feed Rate. If this is your first fire or you are trying different pellets, set the feed adjuster to #4, Fig. 19. This is a conservative number and will probably need to be increased. After you know a feed rate setting that works well, use that setting. Remember, if your feed rate is too high you may waste fuel.

5. This is usually a weekly maintenance procedure. Cleaning the burn pot with the scraper with a small amount of new fuel in the bottom is not a problem. First, scrape the ashes on the front of the burn pot into the ash pan. Then scrape the holed surface downward into the burn pot. When the stove is ignited these scrapings will be pushed out by the feeder.

6. The ash pan can hold the ashes from approximately 1 ton of premium fuel. This means the ashes will only need to be emptied a few times a year.

7. Setting the feed adjuster # for maximum burn: With the unit burning in "AUTO", turn to "Stove Mode" and put the fan on "H". Set the Temperature Dial to #7. Allow the unit to burn for about 30 minutes and check ash on front of burn pot. Fig. 21. If the ash line is larger than 1", turn the feed adjuster from #3 to #4. Allow another 30 minutes of burn time and check again. If, at #6 setting, a 1" or less ash bed is not obtainable, it is not a problem. The 1" ash bed is only a maximum burn rate and at most normal settings the ash bed will be larger.

## Starting First Fire Ignitor Switch to "MANUAL" (down position)

Make sure the unit is plugged into a 120 VAC, 60 HZ electrical source. The power light should be the only light lit.

1. Turn FEED ADJUSTER to desired feed rate. No. 4 is good for most pellets.<sup>4</sup>
2. Turn the MODE SELECTOR to "OFF" and then to the desired mode. This will reset control and start the combustion motor.
3. Turn the TEMPERATURE DIAL to the desired setting.
4. Clean burn pot with scraper if necessary.<sup>5</sup>
5. Fill burn pot with pellets, only level with front edge. (Do Not Over Fill).
6. Add starting gel on top of the pellets. Stir gel into pellets for fast lighting.
7. Light starting gel with a match, and close the door. Operation will begin when the fire reaches the proper temperature.<sup>3</sup>
8. Fill hopper with pellets and remove ashes as required.<sup>1, 6</sup>

### Warning

"NEVER USE GASOLINE, GASOLINE-TYPE LANTERN FUEL, KEROSENE, CHARCOAL LIGHTER FLUID, OR SIMILAR LIQUIDS TO START OR "FRESHEN UP" A FIRE IN THIS HEATER. KEEP ALL SUCH LIQUIDS WELL AWAY FROM THE HEATER WHILE IN USE".

# P61A-2 AUTOMATIC IGNITION ESP CONTROL

## Power Light

Indicates power to the control.

## Status Light

Will be lit in either stove or room temp mode when pointer is not within off position band except after normal shut down. Blinks to indicate errors listed below.

Indicates power to distribution blower.

Indicates power to combustion blower

Indicates power to the feed motor.

Indicates ignitor is on.

## Temp dial

Allows you to adjust the room temperature in Room Temp Mode using the outer scale marked in degrees Fahrenheit. It also allows you to adjust the stove temperature while in Stove Temp Mode using the inner scale marked from 1 to 7.

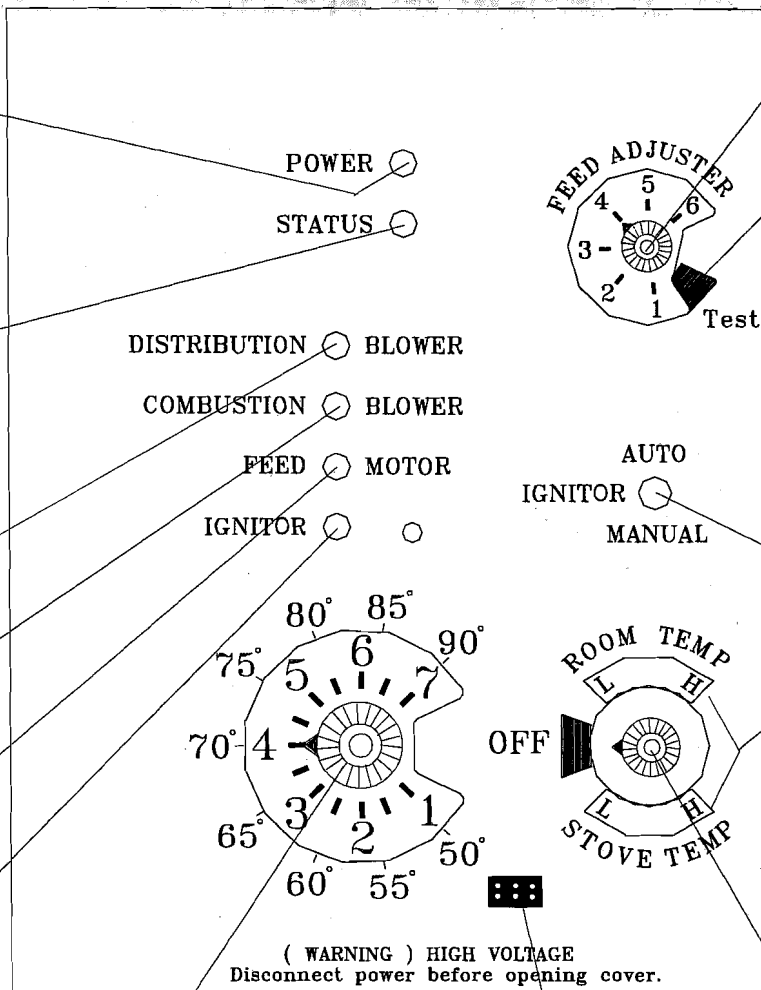

## Feed adjuster

Sets the maximum feed rate

## Test

Runs all motors at full speed for one minute to check operation. After two minutes the stove will go to minimum burn and the blowers will alternate from high to low every minute to remind you that you are still in "Test Mode".

## Ignitor switch

Set to appropriate Start-Up mode.

Distribution Blower speed adjustment range.

L = low

H = high

Variable speed anywhere between L and H; although as the stove temp. goes up, so does the L and H scale.

## Mode Selector

Allows you to choose between Room Temp Mode, Stove Temp Mode, or OFF. Also allows you to vary the distribution blower speed by turning the knob to the high or low side of each mode.

## Dealer Diagnostic Port

For dealer maintenance only. Requires special DDM monitor supplied to Harman Dealers exclusively.

## Status light error messages:

**1 Blink:** Indicates control board self diagnostic failure. This requires a manual reset\*.

**2 Blinks:** Indicates that the jumper (J2) on the rear of the control board is not connected. Without this jumper the unit will only burn at minimum rate.

**3 Blinks:** Indicates ESP (Exhaust Sensing Probe) failure. This requires a manual reset\*.

**4 Blinks:** Can occur only in Room Temp Mode and indicates Room Sensing Probe failed or not installed. If a Room Sensing Probe is then installed, the status light will automatically reset.

**5 Blinks (In Igniter Auto. Mode Only):** Indicates that the unit has failed to light within the 36 minute start cycle. To reset - Turn Mode Selector to "OFF", then

17 turn to either mode again.)

**6 Blinks:** Indicates that the control has calculated poor or incomplete combustion occurring for more than 50 minutes.

A six blink status may be set if the stove is allowed to run out of pellets. To reset, turn mode selector to "OFF" then back on to the desired mode. If the unit was not out of pellets, see Troubleshooting section for more details.

\* **Manual reset-** disconnect power cord for a few seconds and reconnect. If error still occurs call your Dealer.

**NOTICE:** When power is given to the stove, the control board will blink a few times to indicate current version of control board. This should not be confused with error messages.

# P61A-2 Low Draft Voltage Adjustment

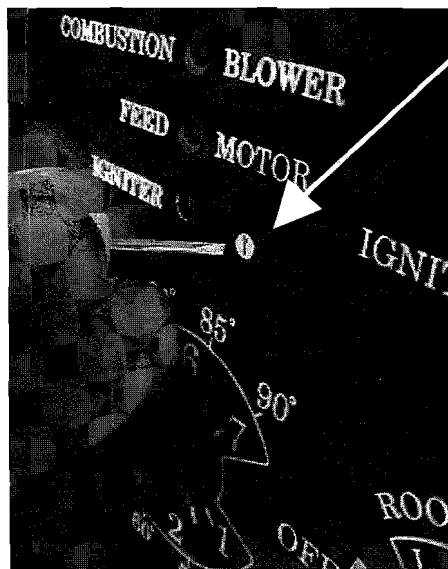
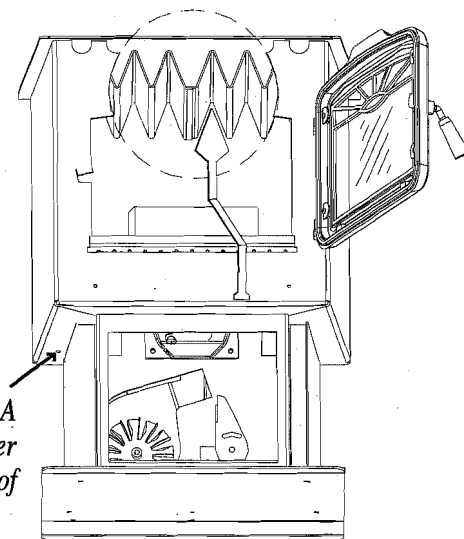

Fig.22

## Combustion Motor Speed Control

**Low draft only set point.**

The small straight screwdriver slot is plastic; therefore, the unit can be adjusted while in operation.



## Draft Meter bolt hole location

On a P61A the draft hole is under the left rear corner of the firebox.

Fig. 23

## Low Draft Voltage Adjustment

These units are pre-tested at the factory with exactly 120 Volts A.C., 60 Hz. They are checked and adjusted for firebox tightness, gasket leakage, motor operation and ignitor operation. The P61A is then factory set at a mid-point adjustment and in most cases will not need any adjustments.

**NOTE: The factory low draft setting may not be correct for the units permanent installation conditions.**

The control board on the P61A is equipped with a low draft adjustment port. Located on the control face just to the right of the igniter light. This voltage adjustment is provided to allow the unit to be adjusted for the household voltage where the unit is going to be in permanent operation. **NOTE:** The line voltage varies from area to area and often home to home.

The low draft voltage should be adjusted to achieve the most efficient burn on low burn or "maintenance". This voltage adjustment allows the installer to change the low voltage set point approximately 10 volts. This adjustment should be done by the installer during set up because a draft meter reading is **required** to insure proper set up.

If the unit is not adjusted properly, it does not cause a safety concern. If the unit is adjusted too high, only efficiency is lost. If the unit is adjusted too low, the low draft pressure switch will not allow the feeder motor or the igniter to operate.

A simple draft test should be performed after completing the flue pipe installation. To record the results for future reference:

1. Plug unit into a 120VAC, 60 HZ outlet.
2. Close the hopper lid, front view door, and the ash pan. Neither pellets or a fire are required for this test.
3. With the mode selector in the "OFF" position, turn the feed adjuster to "TEST".
4. Record the high draft \_\_\_\_\_ in W.C. (Normal is -.50 to -.60) The control will be on the High Draft for a total of 2 minutes.
5. After 2 minutes is up, the combustion motor will go down to low draft and the distribution blower will go on high. Allow approximately 15 seconds to pass for the combustion motor to slow before checking the low draft.
6. If the low draft is between -.35 and -.45, record the reading \_\_\_\_\_ in W.C. If the reading is higher, slowly turn the set screw counter-clockwise until the draft lowers. If the reading is lower, **very slowly** turn the set screw clockwise until the draft increases.

**NOTE: The test mode alternates from high to low draft every 60 seconds. If more time is needed for draft adjustment, wait until the next low draft cycle.**

**NOTE: In some cases, the draft may not go as low as -.35 to -.45 even with the set screw completely counter-clockwise.**

# Room Sensor and Rear Shield Installation

## Room Sensor Installation

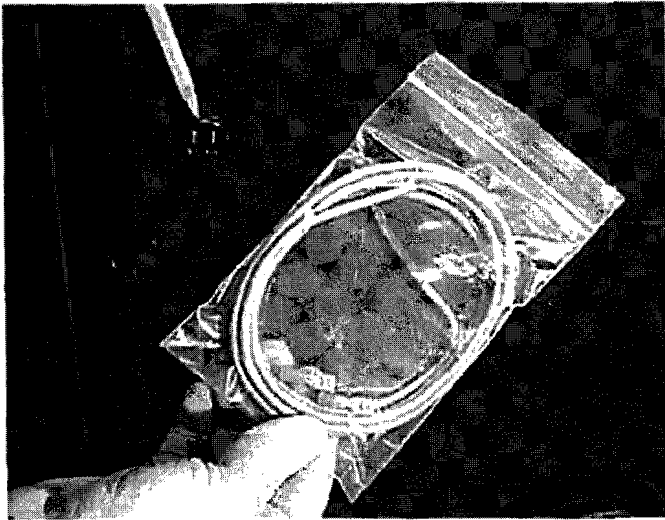

Fig. 24

The room sensor is a small temperature sensor on the end of a 60" gray wire. This sensor is installed much like a standard wall thermostat. Because it is so small, it can be hidden along the trim of a doorway or even up the leg of a coffee table. There is a remote room sensor port on the rear of the unit for easy external connection. Use standard 18-2 thermostat wire to extend the distance to the desired location (100' maximum). The room sensor should be installed in the location where you want to control the temperature.

NOTE: Distances of more than 25 feet from the unit or in another room are not recommended. The room sensor is essential for the P61A's excellent efficiency.

NOTE: It is recommended that the room sensor be installed, even if only installed on the rear of the unit as a return air sensor.

## Rear Shields

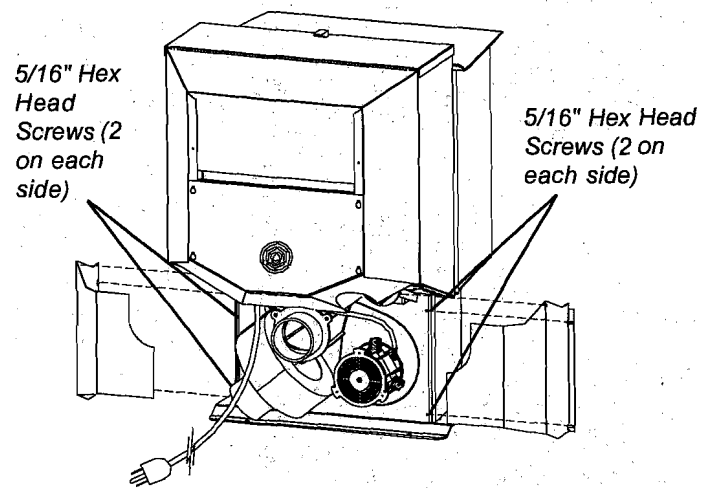
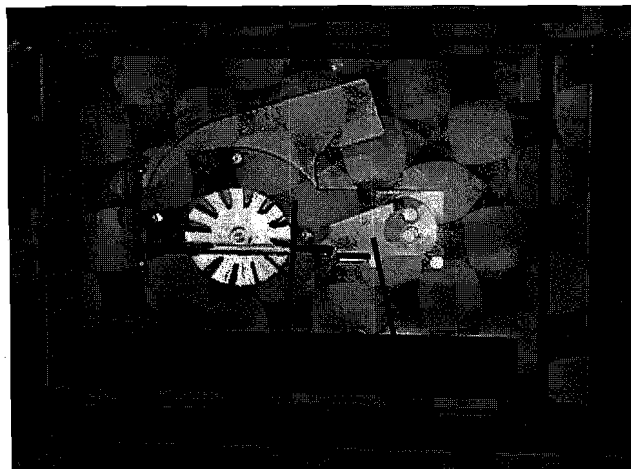

Fig. 25

The rear isolated shields are split in the middle for easy removal. Each shield has two 5/16" hex head screws that only need to be loosened (NOT REMOVED) to allow the shield to slide away from the unit. **NOTE: It is not recommended that the unit be operated with the shields removed, due to the hot and moving parts which they protect.**

# Maintenance



Combustion  
Blower Cover

Blower Cover  
Latch

Fig 26

## Removing Ashes:

When approximately 1 ton of pellets has been burned it will be necessary to empty the ash pan.

Ashes should be placed in a metal container with a tight fitting lid. The closed container of ashes should be placed on a noncombustible floor or on the ground, well away from all combustible materials, pending final disposal. If ashes are disposed of by burial in soil or otherwise locally dispersed, they should be retained in the closed container until all cinders have thoroughly cooled.

It is recommended that the stove is cold and shut down when removing ash pan.

1. Pull on latch handle and remove ash pan as shown at left. Use ash pan handle to carry and dispose of ashes.
2. Slide the ash pan back into the stove and latch by pushing in on latch handle.

## Cleaning:

The stove will need to be cleaned for approximately every 2 to 5 tons of pellets burned. The amount of pellets burned before cleaning will vary depending on the brand of pellets.

1. Shut down stove and **disconnect power cord** to insure that all motors are stopped.
2. Remove ash pan as described earlier.
3. Remove combustion blower cover by turning the blower cover latch vertical as shown in Fig.26 and sliding the cover out of the slot on the left. This will expose the combustion blower wheel and flue outlet, Fig.27.
4. Clean the blower wheel with a brush and a vacuum cleaner.
5. Use a brush to clean the flue, being careful not to damage the ESP probe. The flue goes straight through into the vent pipe (Fig.27) therefore, the vent pipe can also be cleaned to some extent through the flue outlet.
6. Reinstall blower cover and relatch.

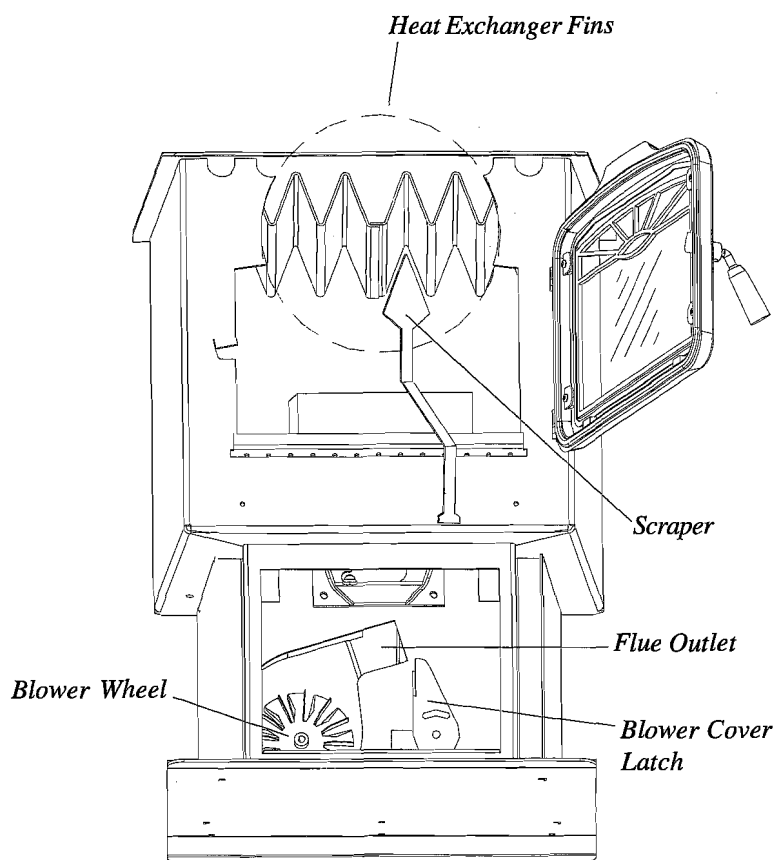

Fig 27

# Maintenance

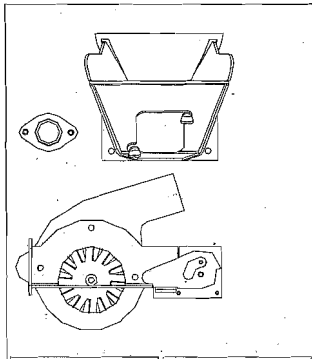

Fig. 28

Latch "closed" with blower cover in place. Burn pot clean-out is closed.

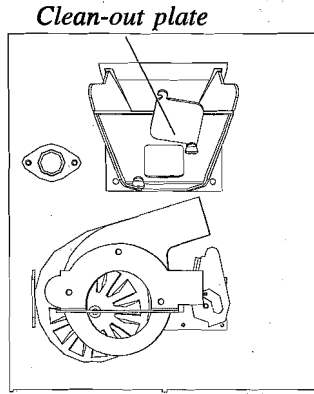

Fig. 29

Latch "open" with blower cover partly removed. Burn pot clean-out is open.

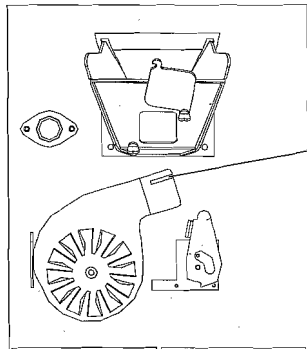
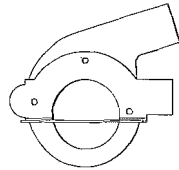

Fig. 30

Exposed blower wheel and flue opening, NOTE: ESP probe is visible.

ESP probe



Blower cover removed.

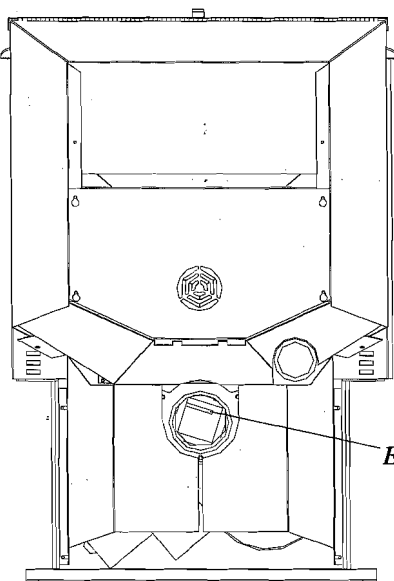
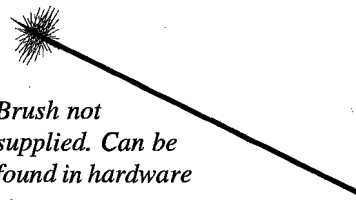

Fig. 31

ESP Probe

Be careful not to damage ESP probe when cleaning with brush.

7. Open burn pot clean-out as shown to the left, clean fly ash from burn pot and replace cover.
8. Clean heat exchanger with scraper as shown in fig 25.
9. Brush or scrape the inside of the stove to remove fly ash.
10. Scrape burnpot with flat end of scraper provided with the stove. Fig. 33.
11. Slide ash pan into stove and latch into place.



Brush not supplied. Can be found in hardware stores.

Fig. 32

## Soot and Fly Ash

The products of combustion will contain small particles of fly ash. The fly ash will collect in the exhaust venting system and restrict the flow of the flue gases. Incomplete combustion, such as occurs during startup, shutdown, or incorrect operation of the room heater, will lead to some soot formation which will collect in the exhaust venting system. The exhaust venting system should be inspected at least once every year to determine if cleaning is necessary.

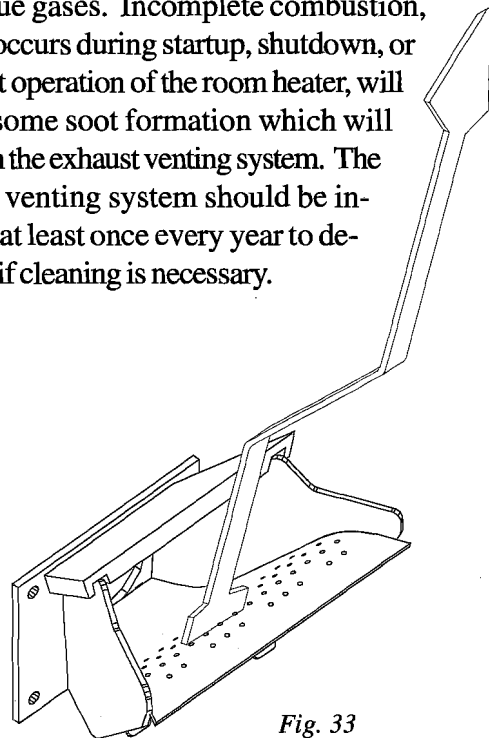

Fig. 33

## P61A-2 Maintenance - Burn Pot

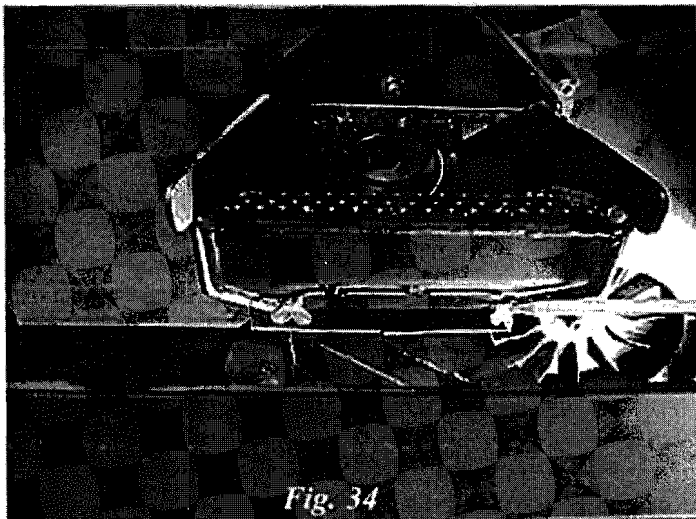

Fig. 34

### Burn Pot Cleaning and Maintenance

1. Scrape the top holed surface and sides of the burn pot. (Fig. 34) It is not necessary to completely remove all material from the burn pot. The excess will be pushed out during the next use.
2. Loosen the (2) wing thumb screws on the lower front angle of the burn pot. (Fig. 34)
3. Lift off the clean-out cover (Fig. 35) to open the bottom clean-out chamber. (Fig. 36)

#### **DANGER**

***Disconnect the power to the unit before removing cover.***

4. Clean ash buildup from inside the chamber while cover is off. Use the scraper to tap on the top front edge of the burn pot. This will help knock pieces of ash, loosened by the scraping process, down through the holes. It also helps knock scale off of the ignitor element.

### Figure 36

The ignitor is made to be removable for service by insulated male/female wire connectors. These connections between the hot leads (the wires inside the burn pot) and the cold leads (the wires from the control board) are always pulled to the inside rear of the feeder body. (**Not coiled inside the burn pot.**)

It is very important that these connections are to the inside rear of the feeder body. Also, the extra wire of the ignitor wire service loop must be pulled out through the rear of the feeder and tied up so that it will not be damaged by any moving parts.

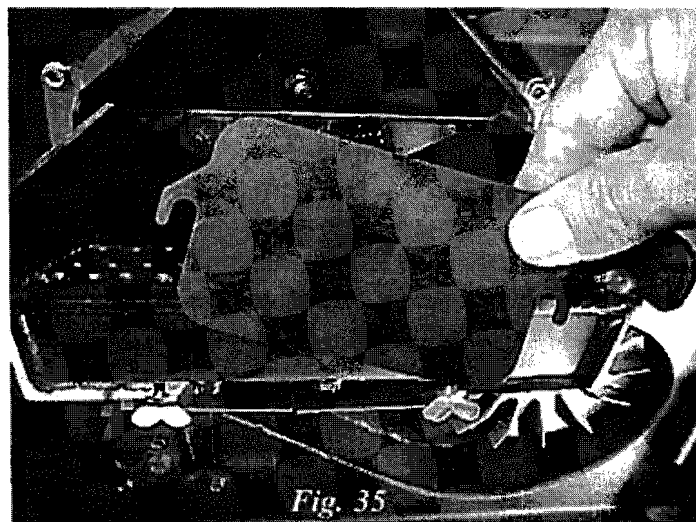

Fig. 35

#### **DANGER**

***Disconnect the power to the unit before removing cover.***

#### **Warning**

***Use caution when cleaning burn pot clean-out chamber. Do not damage the high temperature igniter wires.***

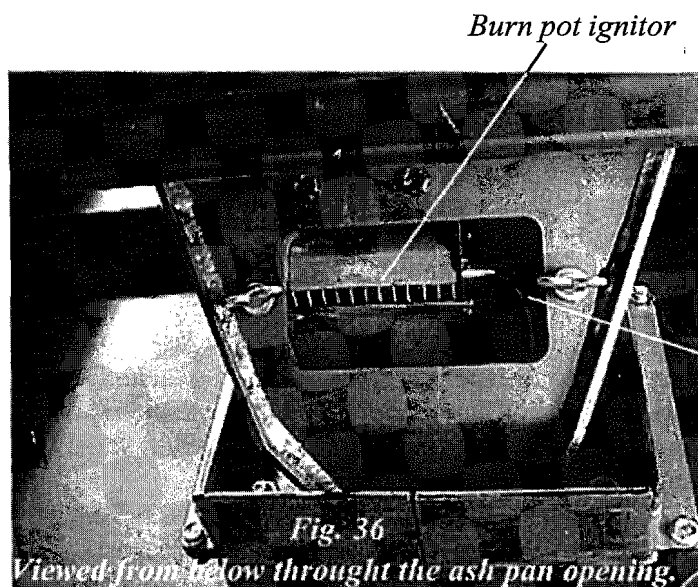

Fig. 36

Viewed from below through the ash pan opening.

*Ignitor hot lead wires  
(high temperature)*

**Note: The hot lead/cold lead connection must always be pulled to the rear of the feeder body before operation.**

# P61A-2 Trouble-Shooting

## FEEDER DOES NOT FEED

1. No pellets in hopper.
2. Firebox draft may be too low for low draft pressure switch in feeder circuit to operate. **Check for closed doors**, loose or missing gasket on doors or hopper lid, faulty pressure switch.
3. Feed motor will not run until ESP senses 165 deg. F. Maybe you did not put enough pellets in the burn pot before lighting the fire.
4. Something is restricting flow in the hopper or causing the slide plate to stick.
5. Feed motor has failed.

## PARTIALLY BURNED PELLETS

1. Feed rate too high.
2. Draft too low. (Check burn pot clean out slide and door gasket).
3. Burn pot or heat exchanger tubes may need to be cleaned.
4. Combination of all the above.
5. #6 status blink: A 6 blink control board status indication is caused by poor or incomplete combustion. The Automatic Ignition circuit board has the ability to track the combustion through feed settings and ESP temperatures. When the control board has calculated poor or incomplete combustion it will shut down the unit as a safety feature. (Poor or incomplete combustion is a contributor of creosote which may cause a chimney fire)

A 6 blink status may be caused by several things:

1. Blocked or partially blocked flue.
2. Blocked or partially blocked inlet air.
  - a. backdraft damper on the inlet pipe may be stuck closed.
  - b. if outside air is installed the inlet cover may be blocked.
3. The air chamber under the burnpot may be filled with fines and small bits of ash.
4. The holes in the burnpot may be getting filled with ash or carbon buildup.
5. Combustion blower fan blades may need cleaned.
6. No fuel in hopper.

## SMOKE SMELL

Seal the vent pipe joints and connection to stove with silicone.

## FIRE HAS GONE OUT

1. No pellets in hopper.
2. Draft setting is too low.
3. Something is restricting fuel flow.
4. Feed motor or draft motor has failed.
5. Power failure or blown fuse.

## SMOKE IS VISIBLE COMING OUT OF VENT

1. Air-fuel ratio is too rich.
  - A. Feed rate too high.
  - B. Draft too low caused by a gasket leak.

## LOW HEAT OUTPUT

1. Feed rate too low
2. Draft too low because of gasket leak.
3. Poor quality or damp pellets
4. Combination of 1. and 2.

## Helpful Hints

### Cleaning Burn Pot

Whenever your stove is not burning, take the opportunity to scrape the burn pot to remove carbon buildup. A vacuum cleaner is handy to remove the residue. Be sure the stove is cold if you use a vacuum.

Carbon buildup can be scraped loose with the fire burning using the special tool provided with your stove. Scrape the floor and sides of the burn pot. The carbon will be pushed out by the incoming fuel. Always wear gloves to do this.

### Removing Ashes

Turn the Temp Dial to number 1 approximately 30 minutes before removing ashes. This will result in a cooler stove and ash pan.

Maximum Feed Adjuster settings are not needed in most cases. Operating in the normal range (#4) is recommended when maximum heat output is not required. The ESP probe prevents the stove from being over-fired.

Keep the stove free of dust and dirt.

## Fuel

Pellet fuels are put into 3 categories in terms of ash content. Premium at 1% or less, Standard at 3% or less and all others at 3% or more.

The P61A is capable of burning all 3 categories of pellets due to a patented feeder and burn pot system.

It should be noted, however, that higher ash content will require more frequent ash removal and may provide less BTU's per pound. Normally, standard and high ash pellets cost less than premium pellets and can be cost effective when burned in the P61A.

The moisture content must not exceed 8%. Higher moisture will rob BTU's and may not burn properly.



# P61A-2 Feeder and Specifications

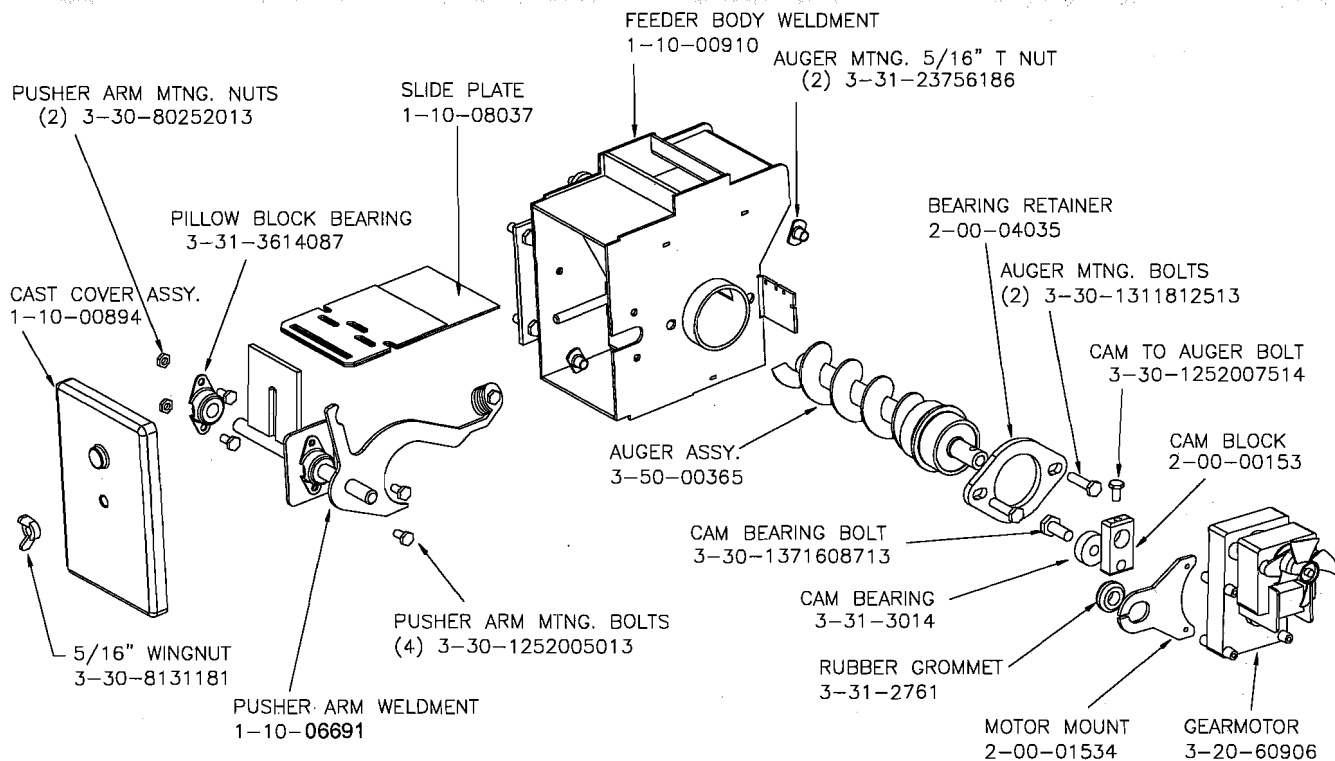

## Specifications

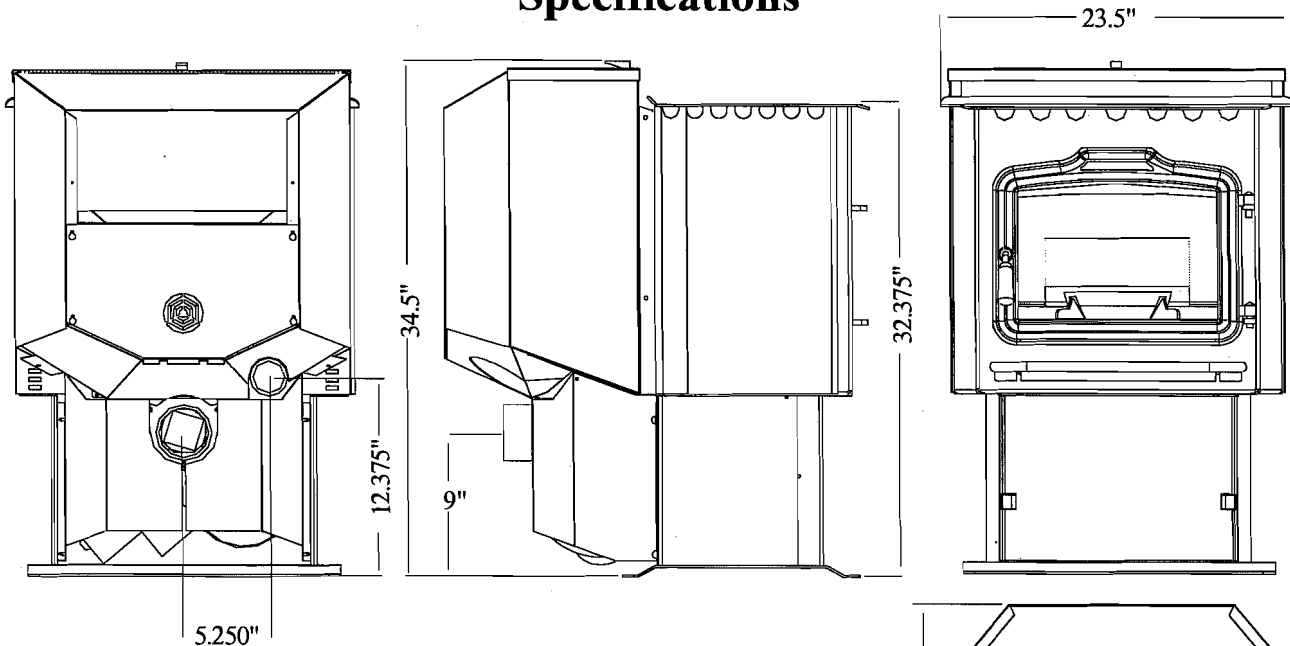

<b>Weight</b>	<b>249 lbs.</b>
<b>Blower</b>	<b>135 cfm</b>
<b>Feed Rate</b>	<b>.75 to 7.5 lbs. per hr.</b>
<b>Hopper Capacity</b>	<b>72 lbs.</b>
<b>Fuel</b>	<b>Wood Pellets</b>
<b>Flue Size</b>	<b>3 inch</b>
<b>Outside Air Size</b>	<b>2 3/8 I.D. inch</b>
<b>Fuse Rating</b>	<b>5 amp</b>

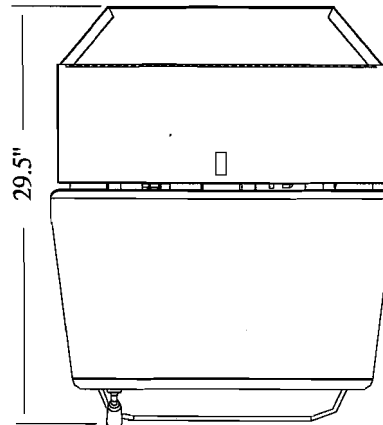

## Door Options

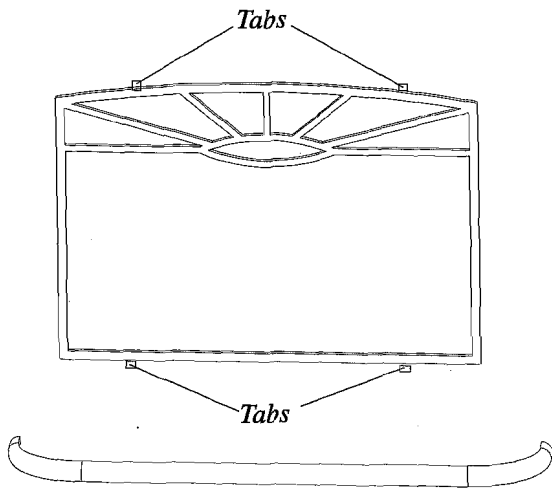

### "Sunrise" Gold Trim

This kit includes a gold trim piece for the ash lip and a gold Sunrise piece for the door.

Referring to the diagram, page 5, note how the various components of the door system fit together. Lay the load door face down on a soft surface.

Clean the glass thoroughly using a nonabrasive glass cleaner. Install the glass gasket around the outer edge of the front face of the door glass carefully to insure proper sealing.

Note: There are 4 tabs on the Sunrise. These tabs have a step on the front side and are flush on the back side. Place the "Sunrise" in the door so the step side is to the front.

Set the glass pane gently onto the door. Install the hold-down clips and tighten with bolts as shown on page 5.

To install ash lip trim, simply slide the trim over the ash lip and into the groove on the trim.

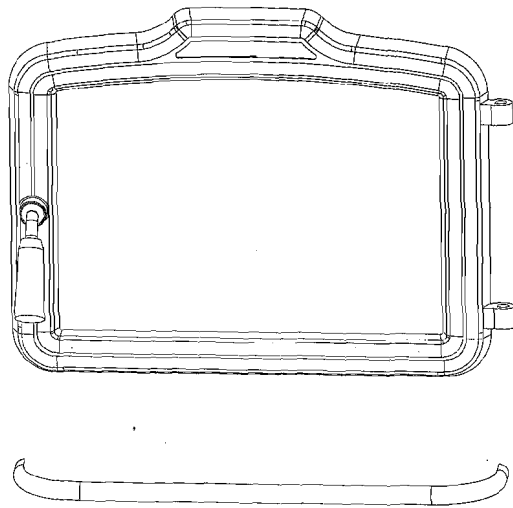

### Gold Door

The gold door is assembled and installed the same as the standard door. Refer to page 5. Be careful not to scratch the glass and be sure to clean the gold before starting a fire in the stove.

To install ash lip trim, simply slide the trim over the ash lip and into the groove on the trim.

### Cleaning Gold

The gold plated door and gold Sunrise should never be buffed or polished. Abrasive cleansers and metal polishes will remove the plating and therefore should never be used. If the gold needs to be cleaned, wait until the stove is completely cool, then use a sponge, soap and water to gently remove dirt and stains. Before relighting the stove, remove all soap residue and wipe dry.

# OPTIONS

## Side Heat Shields

Side heat shields are available to reduce the clearance to combustible materials.

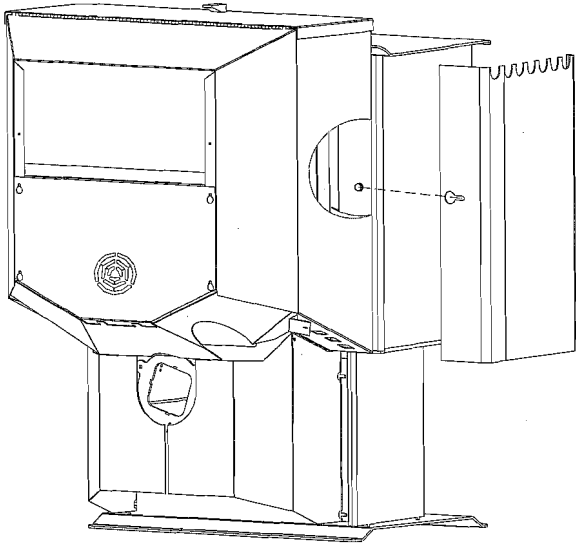

## Hopper Extension

The hopper extension allows you to put more pellet fuel in the hopper and extends burn time on one load of pellets. The hopper extension adds 60 pounds to the existing 72 pound hopper capacity, allowing you to load 132 pounds of pellets at one time.

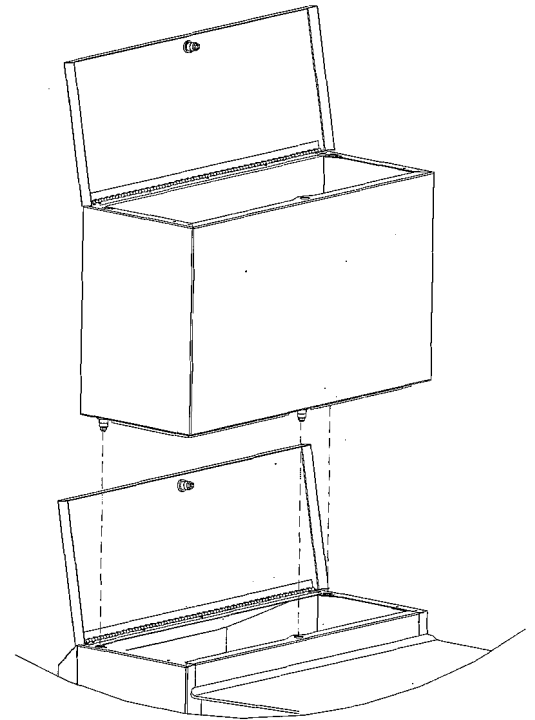

### HARMAN P61A-2 PELLET STOVE WIRING DIAGRAM

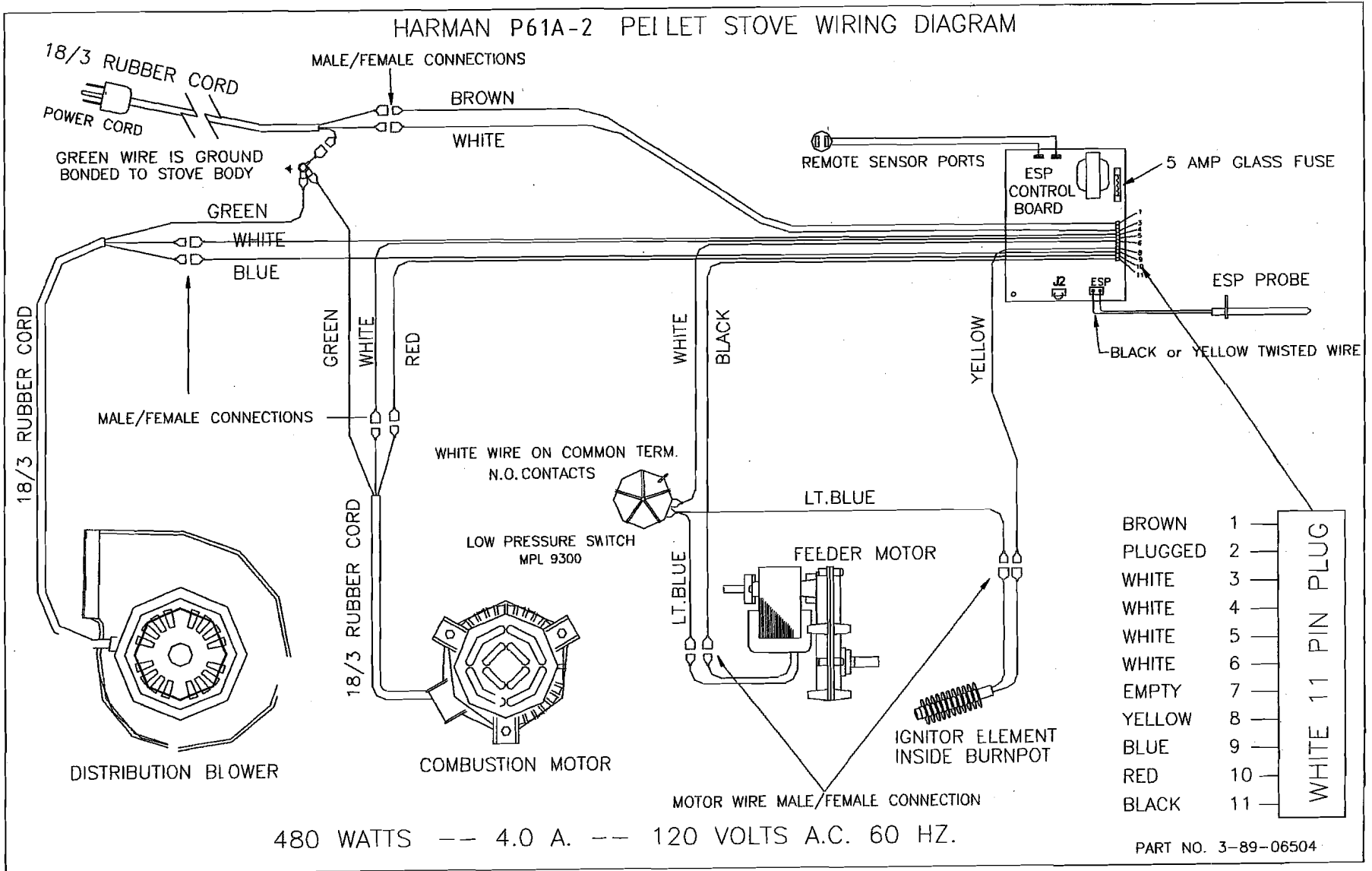

P61A-2 Wiring Diagram

## P61A-2 Parts List

<u>Description</u>	<u>Part Number</u>
Hopper Gasket(6 ft.)	0-88-00248
Ash Pan Assembly	1-10-05800
Burn Pot Weldment	1-10-05802
Right Rear Shield	2-00-06468-1
Left Rear Shield	2-00-06468-2
Arrow Scraper	2-00-773850
Flame Guide	3-00-08534
Wiring Harness Assembly	3-20-08727
Thermister Probe	3-20-00744
Room Sensor	3-20-00906
Circuit Board	3-20-05292
Differential Switch	3-20-9301
5" Double Fan Blade	3-20-502221
Combustion Blower	3-21-08639
Distribution Blower	3-21-22647
Hopper Lid Latch	3-31-199110
3/16" Rubber Washer (for Hopper Lid)	3-31-90131101
Power Cord	3-20-29685
Auto Ignite Label (Control Panel Door)	3-90-08627
Fire Brick (3)	3-40-900450125
White/Black Control Knob(3)	3-31-00968
Control Knob Shaft(3)	3-31-00982
Front Glass	3-40-950133125
Burn Pot Gasket(2)	3-44-00409
Tailpipe Gasket	3-44-06179
Wiring Diagram	3-89-06504
Control Panel Sticker	3-90-06655
Owner's Manual	3-90-05800
Hopper Lid Label	3-90-08623
Ignitor Assembly	1-10-06620
Cleanout Cover(1)	2-00-06623
1/4-20 x 1/2" Wing Screw w/Collar(2)	3-31-782108
Hopper Extension Assembly	1-00-08636
<u>Options:</u> Outside Air Assembly	1-10-08542
3' Flex Pipe	2-00-08543
Log Set	3-40-5647
Gold Plated Door Kit	1-00-08520-4
Gold Ash Lip Trim	with door kit
Ash Door Tile Pack(trim & backer plate)	1-00-08618
Tile Pack(1 piece)	3-43-12601(10 choices)

**HARMAN GOLD WARRANTY**  
**6 YEAR TRANSFERABLE LIMITED**  
**WARRANTY (Residential)**  
**1 YEAR LIMITED WARRANTY (Commercial)**



Harman Stove Company warrants its products to be free from defects in material or workmanship, in normal use and service, for a period of 6 years from the date of sales invoice and for mechanical and electrical failures, in normal use and service, for a period of 3 years from the date of sales invoice.

If defective in material or workmanship, during the warranty period, Harman Stove Company will, at its option, repair or replace the product as described below.

The warranty above constitutes the entire warranty with respect to Harman Stove Company products. HARMAN STOVE COMPANY MAKES NO OTHER WARRANTY, EXPRESSED OR IMPLIED, INCLUDING "ANY" WARRANTY OF MERCHANTABILITY, OR WARRANTY OF FITNESS FOR A PARTICULAR PURPOSE. No employee, agent, dealer, or other person is authorized to give any warranty on behalf of Harman Stove Company. This warranty does not apply if the product has been altered in any way after leaving the factory. Harman Stove Company and its agents assume no liability for "resultant damages of any kind" arising from the use of its products. In addition, the manufacturer and its warranty administrator shall be held free and harmless from liability from damage to property related to the operation, proper or improper, of the equipment.

THERE ARE NO WARRANTIES WHICH EXTEND BEYOND THE DESCRIPTION ON THE FACE HEREOF.

THESE WARRANTIES APPLY only if the device is installed and operated as recommended in the user's manual.

THESE WARRANTIES WILL NOT APPLY if abuse, accident, improper installation, negligence, or use beyond rated capacity causes damage.

HOW TO MAKE A CLAIM - Any claim under this warranty should be made to the dealer from whom this appliance was purchased. Then contact is made with manufacturer, giving the model and serial numbers, the date of purchase, your dealer's name and address, plus a simple explanation of the nature of the defect. Extra costs such as mileage and overtime are not covered. Nuisance calls are not covered by these warranties.

THIS WARRANTY IS LIMITED TO DEFECTIVE PARTS - REPAIR AND/OR REPLACEMENT AT HARMAN STOVE COMPANY'S OPTION AND EXCLUDES ANY INCIDENTAL AND CONSEQUENTIAL DAMAGES CONNECTED THEREWITH.

WARRANTY EXCLUSIONS: Failure due, but not limited to, fire, lightning, acts of God, power failures and/or surges, rust, corrosion and venting problems are not covered. Damage and/or repairs including but not limited to; remote controls, filters, fuses, knobs, glass, ceramic brick panels, ceramic fiber afterburners, door packing, tile, ceramic log sets, paint, batteries or battery back-up and related duct work are not covered. Also excluded from this warranty are consumable or normal wear items including but not limited to; flame guides, grates, coal bars, afterburner hoods, fire brick, gaskets. Additional exclusions for corn stoves are burnpot housing weldment, burnpot grate weldment (pellet or corn), burnpot front plate (pellet or corn), burnpot front plate lock, corn auger extension, ceramic insert, and ceramic insert plate. Additional or unusual utility bills incurred due to any malfunction or defect in equipment and the labor cost of gaining access to or removal of a unit that requires special tools or equipment are not covered. Maintenance needed to keep the stove in "good operating condition" is not covered. This includes, but is not limited to, cleaning, adjustment of customer controls and customer education. Labor, materials, expenses and/or equipment needed to comply with law and/or regulations set forth by any governmental agencies are not covered.

This Warranty provides specific legal rights and the consumer may have other rights that vary from state to state.

In the event of change in ownership, the remaining portion of this warranty may be transferred to the new owner by sending the new owner information and a transfer fee of \$25.00 US to the Harman Stove Company.

PLEASE READ THE LITERATURE BY THE MANUFACTURER FOR THE VARIOUS ACCESSORY DEVICES. THE MANUFACTURER WARRANTS THESE ACCESSORY DEVICES, NOT HARMAN STOVE COMPANY OR THEIR WARRANTY ADMINISTRATOR. FURTHERMORE, THESE ACCESSORY DEVICES MUST BE INSTALLED AND USED ACCORDING TO THE RECOMMENDATIONS OF THE MANUFACTURER.

REMEDIES - The remedies set forth herein are exclusive and the liability of seller with respect to any contract or sale or anything done in connection therewith, whether in Contract, in tort, under any warranty, or otherwise, shall not, except as herein expressly provided, exceed the price of the equipment or part of which such liability is based.

CLARIFY - The above represents the complete warranty, which is given in connection with stoves, manufactured by Harman Stove Company. No other commitments, verbal or otherwise, shall apply except by a written addendum to this warranty.

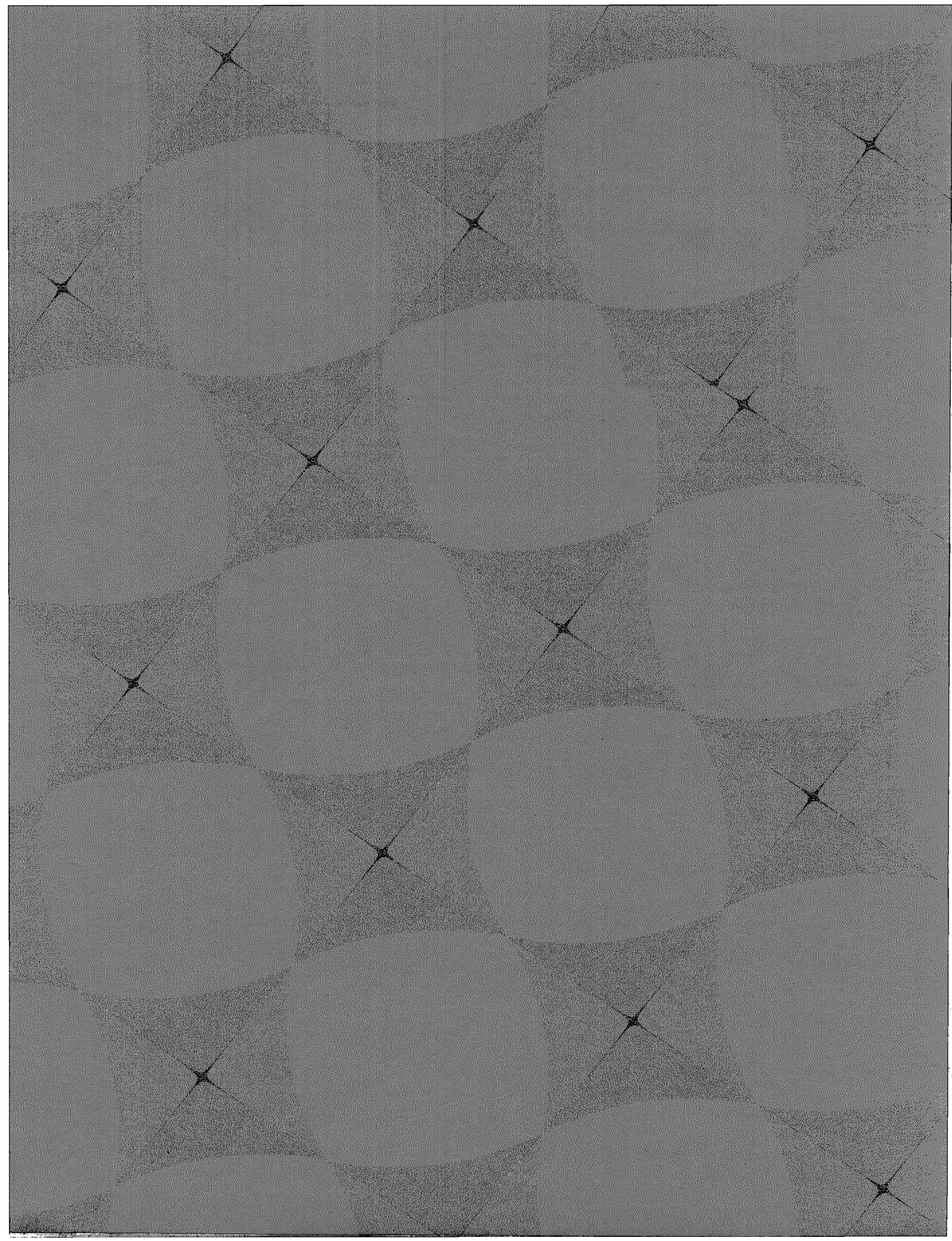

MIP-1643