

Installation & Operating Manual

Harman Oakwood Cast Iron Wood Stove

HARMAN®

BUILT TO A STANDARD, NOT A PRICE

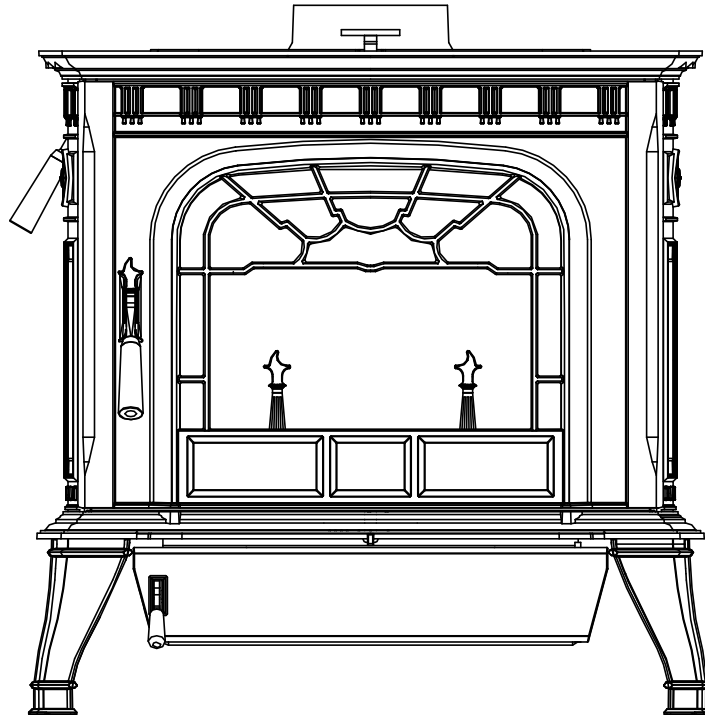

"Ce manuel est disponible en Français sur demande"



SAFETY NOTICE

PLEASE READ THIS ENTIRE MANUAL BEFORE YOU INSTALL AND USE YOUR NEW ROOM HEATER. FAILURE TO FOLLOW INSTRUCTIONS MAY RESULT IN PROPERTY DAMAGE, BODILY INJURY, OR EVEN DEATH.

FOR USE IN THE U.S. AND CANADA. THE OAKWOOD IS NOT APPROVED FOR MOBILE HOME INSTALLATION.

IF THIS HARMAN STOVE IS NOT PROPERLY INSTALLED, A HOUSE FIRE MAY RESULT. FOR YOUR SAFETY, FOLLOW INSTALLATION DIRECTIONS.

CONTACT LOCAL BUILDING OR FIRE OFFICIALS ABOUT RESTRICTIONS AND INSTALLATION INSPECTION REQUIREMENTS IN YOUR AREA.

CONTACT YOUR LOCAL AUTHORITY (SUCH AS MUNICIPAL BUILDING DEPARTMENT, FIRE DEPARTMENT, FIRE PREVENTION BUREAU, ETC.) TO DETERMINE THE NEED FOR A PERMIT.

CETTE GUIDE D'UTILISATION EST DISPONIBLE EN FRANCAIS. CHEZ VOTRE CONCESSIONNAIRE DE HARMAN HOME HEATING.

SAVE THESE INSTRUCTIONS.

INDEX

Introduction	4
Specifications	5
Operation/Building a Fire	7
→ Installation	11
Venting	16
Maintenance	25
Options	27
→ Service Parts	28
Warranty	32

→ = Contains updated information

NOT APPROVED FOR MOBILE HOME INSTALLATIONS

Please read this entire manual before you install and use your new heating appliance. Failure to follow instructions may result in property damage, bodily injury, or even death.

HARMAN®

BUILT TO A STANDARD, NOT A PRICE

352 Mountain House Road
Halifax, PA 17032
U.S.A.

INTRODUCTION

Thank you for purchasing the Harman Oakwood. We are confident that you will enjoy the warmth and convenience of your Harman Stove for decades to come.

The Harman Oakwood will heat your home while also being multi-functional and visually appealing. When building your Oakwood, we used only the best precision castings that were designed, so accurately, that gaskets are used (instead of furnace cement) for assembly.

Harman's special FireDome, Non-Catalytic, Combustion System was created specifically for the Oakwood to promote clean burning and even heat output. What this equates to is unvarying heat throughout your home over a longer period of time without the peaks and valleys of other wood stoves. The FireDome attains Harman's reputation of high efficiency while saving you the expense associated with catalytic stoves. Top loading makes adding wood easier and allows you to view your beautiful fire through the extra large glass door. The glass stays cleaner because of specially coated glass and the exclusive Harman Air Wash System.

The Harman Oakwood has an ash pan with its own ash door that is used to remove ashes while the stove is in operation. This means you can keep one fire all winter if you desire.

The Harman Oakwood offers a cooking grill that can be placed in the top of the stove while in operation. This allows you to grill steaks and burgers etc. all year long, even when the weather is not suitable for outside grilling. If you haven't already purchased the cooking grill, you can do so through your Harman Dealer.

Due to the fact that the Oakwood is hot while in operation, gloves should be worn while tending to the fire.

For your reference, please copy the serial number from the label on your stove to the box below.

SERIAL NUMBER

This appliance is also approved for installation into a shop.



OMNI-Test Laboratories, Inc.
Report #Rapport #135-S-11-2
Tested/Évalué le:
UL 1482
Meets requirements of ULC 5827-639/
Selon les exigences de ULC 5827-639
Certified for U.S.A. and Canada/Certifié
pour les États-Unis et le Canada

LISTED SOLID FUEL FIREPLACE STOVE OR ROOM HEATER/
APPAREIL DE CHAUFFAGE OU POËLE À COMBUSTIBLE SOLIDE

MODEL/Modèle: **OAKWOOD** Serial No. / N° de série: **008**

BARCODE LABEL

PREVENT HOUSE FIRES:
Install and use only in accordance with manufacturer's installation and operation instructions and local building codes. In absence of any local codes, installation must meet minimum requirements of NFPA 211 in USA. Refer to manufacturer's instructions and local codes for precautions required for passing chimney through a combustible wall or ceiling.
FOR USE WITH SOLID WOOD FUEL ONLY.
Don't connect this stove to a chimney serving another appliance.
Flue connector pipe must be 6" diameter, minimum 24 MSG black or 26 MSG blue steel.
Chimney must be factory built 103HT or masonry.
NOTE: Replace glass only with 5mm ceramic glass available from your dealer.
Inspect and clean chimney frequently. Under certain conditions of use, creosote buildup may occur rapidly.
DO NOT OVERFIRE - IF HEATER OR CHIMNEY CONNECTOR GLOWS, YOU ARE OVERFIRING.

PRÉVENTION DES INCENDIES:
Respectez scrupuleusement les instructions du fabricant et les règles et normes applicables dans votre région.
Respectez les règles et normes applicables dans votre région au minimum satisfaisant aux exigences de NFPA 211 en Amérique du Nord. Consultez les instructions du fabricant et les codes locaux pour les précautions à prendre lors du passage des tuyaux de fumée à travers les murs et les plafonds.
N'UTILISEZ QUE DU BOIS SÈCHE.
Ne pas raccorder ce poêle à une cheminée servant une autre appareil.
Le tuyau de fumée doit être en acier inoxydable de 152 mm ou en acier peint de 154 mm de diamètre minimum.
La cheminée doit être construite en maçonnerie ou en acier inoxydable 103HT.
REMARQUE: Remplacer le verre uniquement avec du verre céramique de 5 mm disponible chez votre fournisseur.
Inspectez et nettoyez fréquemment la cheminée. Dans certaines conditions, la suie peut s'accumuler rapidement.
NE PAS SURCHAUFFER - SI LE CHAUFFAGE OU LE CONNECTEUR DE LA CHIMÉE BRÛLE, VOUS SURCHAUFFEZ.

CLEARANCE TO COMBUSTIBLE SURFACE

A - Unit to Sidewall	28"
B - Unit to Backwall	28"
C - Chimney Connector to Side Wall	36"
D - Chimney Connector to Back Wall	32"
E - Unit to Adjacent wall	24"
F - Chimney Connector to Adjacent wall	32"

*See manual for additional installation configurations.

ESPAÇOS LIVRES*

A - Du mur de côté	28"
B - Du mur arrière	28"
C - Du mur de la cheminée	36"
D - Du mur de la cheminée	32"
E - Unité au mur adjacent	24"
F - Connecteur de la cheminée au mur adjacent	32"

*Voir le manuel pour les configurations supplémentaires d'installation.

ELECTRICAL RATING: 115VAC, 60 HZ, 1.1 AMP
DANGER: Risk of electrical shock. Disconnect the power cord under or away from unit.
CAUTION: RISK OF FIRE. DO NOT TOUCH. KEEP CHILDREN AND PETS AWAY FROM THIS APPLIANCE.

PUISSANCE ÉLECTRIQUE: 115VAC, 60 HZ, 1.1 AMP
DANGER: Il y a un risque de choc électrique. Déconnectez le fil électrique avant le service. Éloignez le fil électrique de l'appareil. Ne placez pas le fil électrique sous ou à l'avant de l'appareil.
ATTENTION: IL Y A RISQUE DE TEMPÉRATURES EXCESSIVES ET DE DOMMAGE À L'APPAREIL. UN BON FONCTIONNEMENT EXIGE L'USAGE D'ANTHRACITE DE CHARBON DE GROSSEUR D'UN POIS, D'UNE NOIX OU D'UN CHARBON.

CAUTION: DO NOT TOUCH. KEEP CHILDREN AND PETS AWAY FROM THIS APPLIANCE.



ATTENTION: CHAUD-NE PAS TOUCHER. TENIR LES ENFANTS ET LES VENTEMENTS À L'ÉCART. RISQUE DE BRÛLURE. VOIR INSTRUCTIONS SUR LA PLAQUE. LAISSER UNE DISTANCE SUFFISANTE ENTRE L'APPAREIL ET LES MEUBLES OU AUTRES OBJECTS À RISQUE.

Manufactured by/Fabriqué par: Harman Home Heating
352 Mountain House Road
Halifax, Pa 17032

The label shown here is for reference only. For specific information on clearances and testing, consult the actual label on the rear of the unit.

2012 2013 14 JAN FEB MAR APR MAY JUN JUL AUG SEP OCT NOV DEC

P.N. 3-90-249

Rev B

SPECIFICATIONS

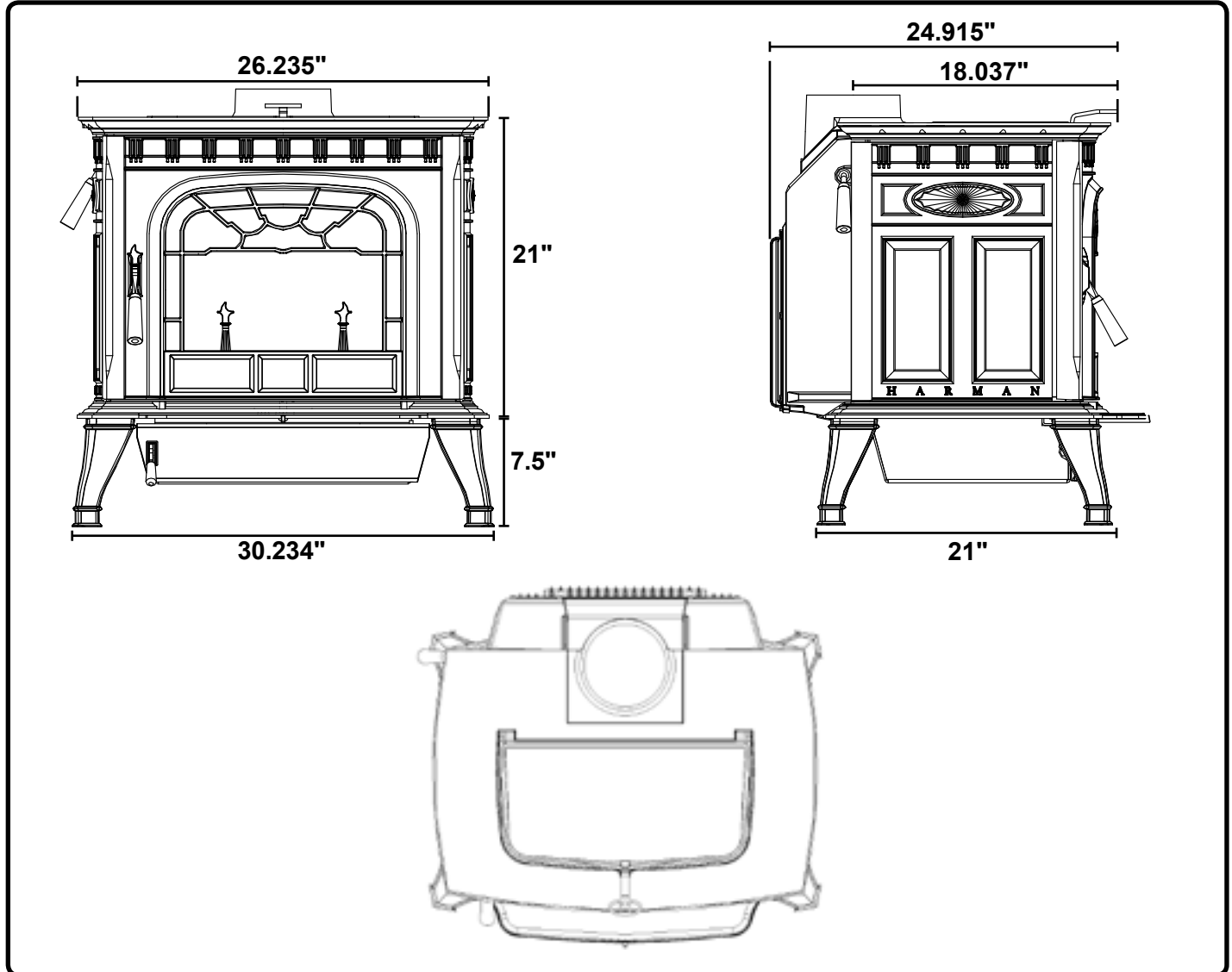

The Harman Oakwood meets the U.S. Environmental Protection Agency's emission limits for wood heaters sold after July 1, 1990.

Weight	440 lbs
Flue Size	6.inch
Log Length Recommended	21." Max
Heating Capacity	2,000 sq. ft.
Average Emissions	2.32 Grams Per Hr.
Emissions on Low	0.8 Grams Per Hr.
Outside Air size	3.or 4 inch

SPECIFICATIONS

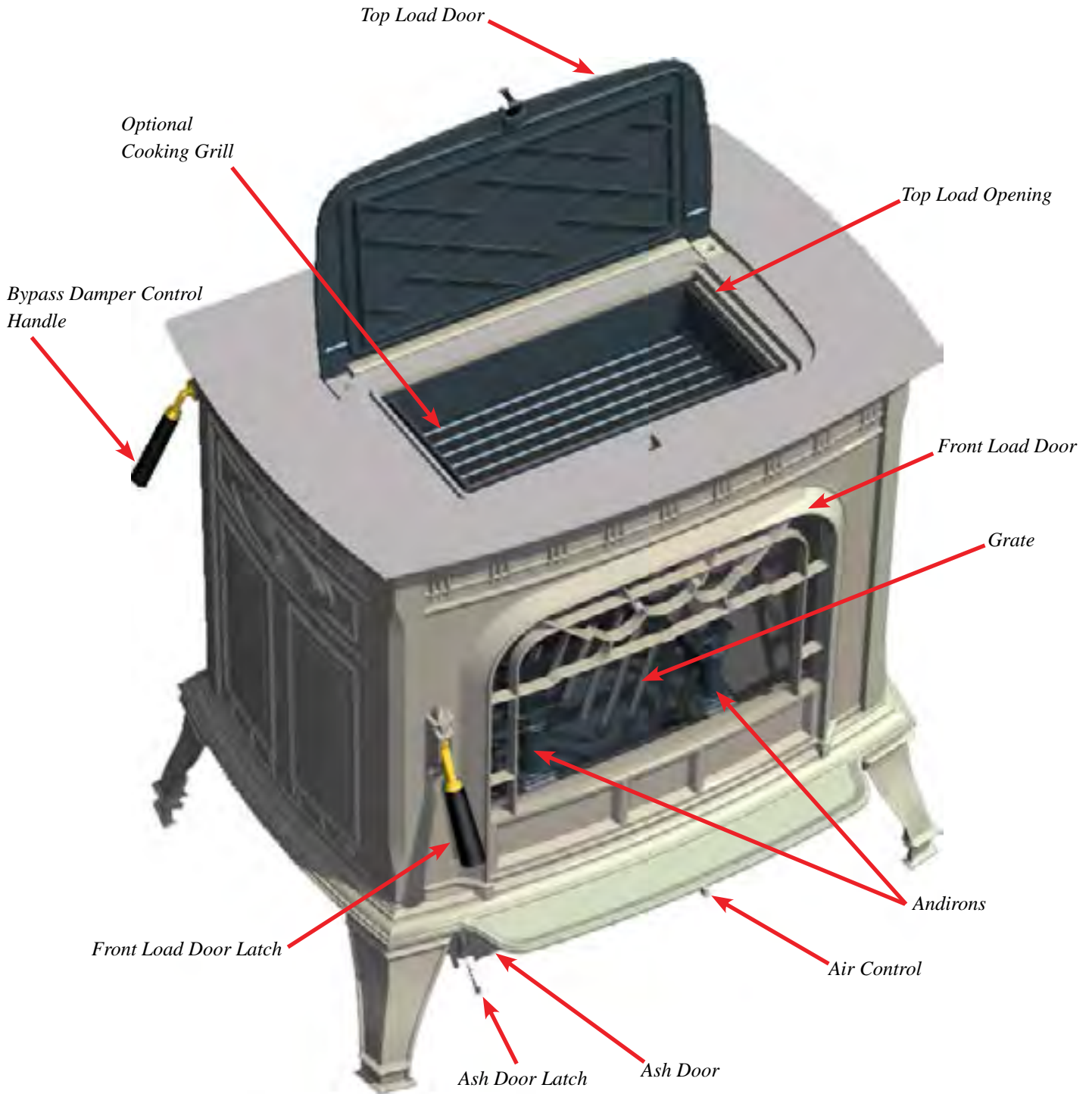

General Considerations

Draft

Before you install and operate your Oakwood wood stove, please read the entire contents of this manual. Pay particular attention to the explanation of draft and its effect on stove performance in the Installation section. By following the installation and operating guidelines, you will ensure proper draft and gain maximum efficiency and enjoyment from your stove.

Fuel

Your Oakwood burns wood very efficiently. Here are some guidelines that will help you achieve the best performance.

Select only **dry, seasoned wood**. Wood for burning should never be exposed to rain or extremely damp conditions. Hardwoods are favored because they are heavier and contain more heating capacity (BTU's) per load than do softwoods. Fuel wood should be split and stored under cover for "seasoning" - at least a year is recommended. Your stove is not an incinerator - do not burn garbage, painted or treated wood, plastic, or other debris.

Keep the area around the stove free from clutter. Keep all combustibles, including fuel, beyond the code-required clearance distance (48" or 1215 mm in the U.S., 1525 mm or 60" in Canada). Never store fuel in front of the stove where it could interfere with door operation, safe loading, and ash removal.

Do not burn garbage or flammable fluids such as gasoline, naptha, or engine oil.

CAUTION:
Always wear fire retardant gloves when operating the stove.

SAFETY NOTICE

IF THIS APPLIANCE IS NOT PROPERLY INSTALLED, OPERATED AND MAINTAINED, A HOUSE FIRE MAY RESULT. FOR YOUR SAFETY, FOLLOW INSTALLATION DIRECTIONS. CONTACT LOCAL BUILDING OR FIRE OFFICIALS ABOUT RESTRICTIONS AND INSTALLATION INSPECTION REQUIREMENTS IN YOUR AREA.

The Stove

Doors

Your stove has a large glass-paneled door for loading and fire viewing, a separate smaller door for removing ashes and a top loading door.

Front Door

Before opening, always check for wood, embers, or ash that may be ready to fall out of the door.

To open the glass door, open the bypass damper first, then lift the handle and pull out; to close the door, push the door closed with the handle in the open position, then push the handle down to engage the latch.

Ash Door

To open the ash door, lift up the handle and pull out. Close the door by pushing in and pushing the handle all the way down.

Top Load Door

To open the top load door, open the bypass damper and then lift to open the top load door.

All doors must be closed while the stove is in normal operation, and the gaskets routinely examined for wear and replaced when necessary. Good door seals are important for maintaining control of the stove. Never operate with the ash door open. Operating the stove with the ash door open, or with a door inadequately sealed, could create a serious overfiring condition (discussed later in this section).

NEVER OPERATE WITH MORE THAN ONE DOOR OPEN AT A TIME

The glass used in your Oakwood is manufactured to exact standards to withstand the high heat of the fire, but like all glass, it must be treated with common sense and care. Never abuse the glass by slamming the door shut or striking the glass with a heavy object. If the glass is broken or damaged, do not operate the stove until it has been replaced (See instructions in the Maintenance section.)

Grates

The Harman Oakwood's unique grate system consists of one flat bottom grate, and two front andirons. The bottom grate has slots which allow the ash to fall into the ash pan by passing a poker back and forth across the grate. The andirons keep the fuel from coming into direct contact with the glass, and keep hot coals and embers from spilling out while reloading. Never build a fire directly against the glass.

The grates and andirons must remain in place at all times. Do not tamper with or change the configuration of this grate system.

Always wear gloves when operating the stove.

OPERATION

Do not burn wet wood!

The Combustion Process

Combustion in the Harman Oakwood is precisely controlled and is best explained in two parts.

During a wood fire, combustion air enters at the bottom front of the stove where it travels upward through channels at either side of the front door. From the manifold located above the front door, it is directed into the firebox as a sheet of air flowing between the glass and the wood. This concept helps to keep the glass clean, while providing the oxygen needed to sustain burning. This is what is known as "Primary Combustion".

Additional air enters at the bottom rear of the stove body. Some of this air enters through holes in the rear bricks where it is used to revitalize the fire at the rear of the firebox. The remainder is delivered into the "Firedome" combustion package where the "Secondary Combustion", or re-burning of the smoke, occurs.

During combustion, the burning of wood proceeds through several stages. The initial or evaporation stage is where the moisture in the wood is driven off in the form of steam. A second stage is where the volatile gases contained in the wood are released and burned. This represents most of the wood's heating capacity. The final stage is the charcoal stage where the charcoal burns the remaining heat content in the wood fuel. Ash remains after the burning is complete. Within the primary firebox two or more of these stages of combustion are occurring at once.

Two important controls - the damper bypass handle and the air control lever regulate the operation and output of the stove.

To open the top or front loading door, you must open the damper bypass, or smoke will come in the room. In this mode of operation the combustion gases go directly from the main combustion chamber to the flue collar and exit into the chimney.

NOTE: The bypass damper must be open for smokeless loading. Open the bypass damper by turning the handle clockwise while facing handle.

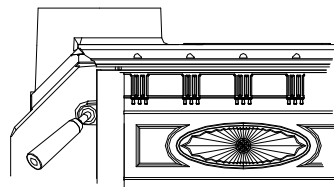

Bypass Damper Open

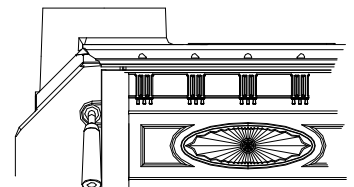

Bypass Damper Closed



Top Load Door Open

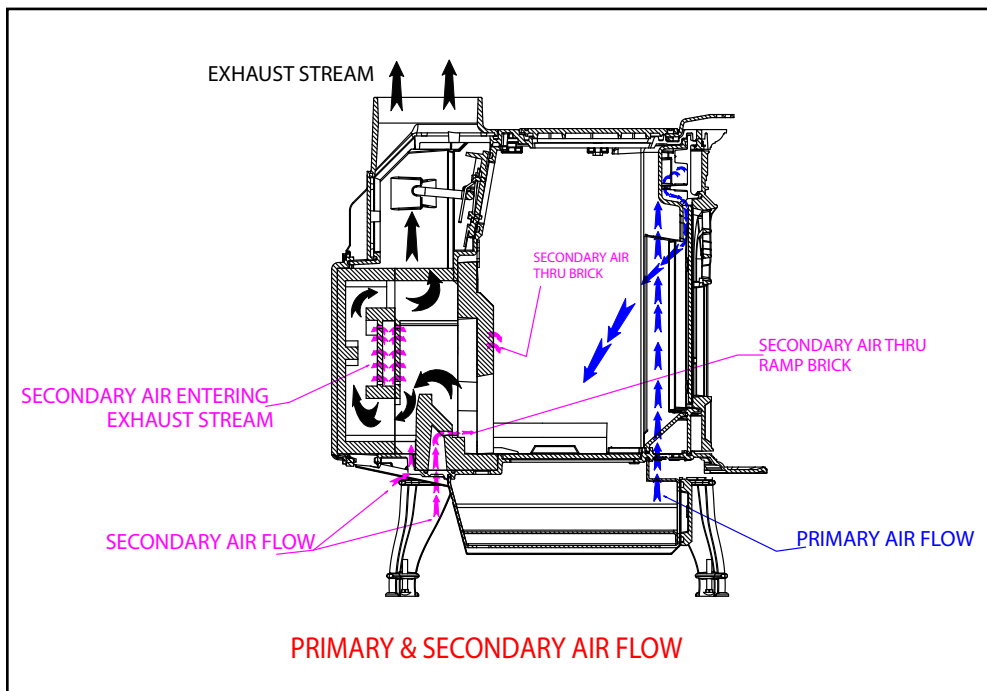

Always wear gloves when operating the stove.

BUILDING A FIRE

Do not burn wet wood!

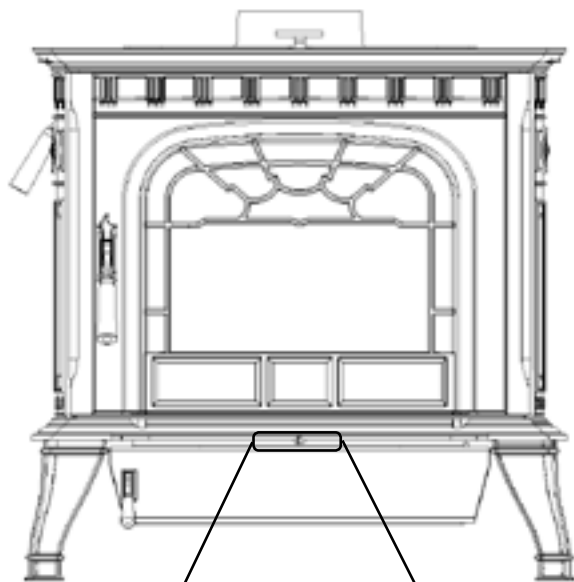

Building and Maintaining the Fire

Do not use chemicals or fluids to start the fire.

Never use gasoline, gasoline-type lantern fuel, kerosene, charcoal lighter fluid, or similar liquids to start or “freshen up” a fire in this heater. Keep all such liquids well away from the heater while it is in use.

Building a Fire

Begin with the bypass damper open, and the air control lever at the maximum setting, all the way to the right. Be sure the ash pan door is closed and latched.

Start with a bed of crumpled paper and kindling sized about finger width; place several 1" - 2" (25mm - 50mm) split pieces of dry wood on top of the kindling, followed by a few 2" - 3" (50 mm - 80 mm) split pieces. Lay the wood in a crossed pattern to allow maximum air flow. Ignite the paper and close the loading door(s). Allow this start-up fire to burn for a few minutes, keeping the bypass damper open. Add about five more pieces of wood in the 2 to 3 inch (50 - 80mm) size range, making sure that the fuel bed is all the way across the firebox and staggered to allow airflow. Close the door and allow this loading to burn a few minutes.

Add increasingly larger pieces of wood to the fire until you have a thick bed of hot embers, approximately 2 to 3 inches deep at the back of the grate and at least an inch deep at the front. **You must have this charcoal bed established before you close the bypass damper.**

Providing you have the charcoal bed described above, close the bypass damper by pulling the handle toward the front of the stove. This will begin the highly efficient mode of operation where the exhaust gases get re-burned in the secondary combustion package. If you cannot achieve a charcoal bed within the first 15 to 20 minutes, your wood is likely too wet, and you may need to burn the fire longer and/or hotter to compensate for the extra energy needed to drive out the moisture.

If, after five minutes of burning with the damper closed, smoke is visible coming from the chimney, you probably do not have the proper coal bed. Open the bypass damper and continue with the process until a significant coal bed is formed.

Always remember to open the bypass damper when you are loading, this allows the exhaust gases to pass directly into the flue outlet and reduces the chance of smoke spillage into the room.

Air Control

The air control lever is located directly below the ash lip of the stove. Sliding this lever allows you to vary the amount of air to the fire, creating a range of heat outputs. The lowest heat output setting is to the left, and the highest is to the right. The notches are provided as a reference for your comfortable heat settings. Do not, under any circumstances, alter the configuration or operation of the air control lever.

For low burn, slide the air control to the left. For medium burns, use notches 4,5 & 6. Maximum heat is attained with the air control all the way to the right. Do not burn the stove continuously at the maximum setting. If maximum heat is required day after day, the stove is too small for the area you are trying to heat.

If your wood is not seasoned long enough or is high in moisture content, you may need to adjust the primary air 1 or 2 notches higher to sustain a low burn rate with the cleanest possible exhaust.

BUILDING A FIRE

Reloading: Once you have prepared and maintained a thick charcoal bed, and the secondary combustion is established, you should be able to reload the stove at any time by simply opening the bypass damper, then the load door, adding fuel and closing the door then the damper. This depends on coal bed size, load size and moisture content of fuel.

Removing Ashes: Before reloading, empty the ash pan (remember to close the ash door while emptying the pan). The ashes should be the coolest at this time. Remove ashes from the fire chamber periodically by raking a poker across the bottom grates.

Excessive ash buildup can prevent proper venting of exhaust gases. Do not allow the ash pan to over-fill. Ash buildup between the ash pan and the bottom of the grate can cause the grate to overheat and wear out prematurely.

The Oakwood was designed to provide access to the ash pan without the need for opening the main door. Before opening the ash door and removing the ash pan, open the bypass damper. Wearing heavy protective gloves, open the ash door and remove the ash pan by pulling it forward by the handle. Close the ash door and damper bypass before taking the ashes outside for safe disposal.

Ashes should be placed in a metal container with a tight fitting lid. The closed container of ashes should be placed on a noncombustible floor or on the ground, well away from all combustible materials, pending final disposal. If the ashes are disposed of by burial in soil or otherwise locally dispersed, they should be retained in the closed container until all cinders have thoroughly cooled.

Never use the ash disposal container for other trash. Wood ash can be added to your garden or compost.

CAUTION

The stove is hot while in operation. Keep children, clothing and furniture away. Contact may cause skin burns.

Never leave the stove unattended if either the ash or load door is open. Overfiring may result.

Risk of Excessive Temperatures. Keep Ash Door Closed During Firing of the Heater.

Overfiring

Avoid overfiring your stove. Overfiring is a potentially hazardous situation which can lead to overheating of combustible materials nearby, damage to the stove, and in extreme cases, cause a fire. Overfiring is caused by: 1. Too much air flowing through the stove too quickly. 2. You may have positioned the primary air control lever too far to the right. 3. Inadvertently leaving the damper open or 4. Not keeping up with routine maintenance, such as checking door gaskets for wear.

Overfiring results in excessive fuel consumption, and may cause parts of the stove or chimney connector to glow red. If you notice signs of overfiring, reduce the air supply to the fire, and review the Maintenance section in this manual.

In the event of a chimney fire, call your local fire department; make sure everyone is safely out of the house. Reduce the air intake of the stove as much as possible using the air control lever; close the bypass damper to further restrict air flow. Do not throw water on the fire; this can cause stove damage and create an even more dangerous situation. Have your chimney professionally cleaned and inspected before resuming burning in your stove.

As you begin to operate your stove at higher temperatures, you will notice a "hot" or unpleasant smell; this is just the paint going through the curing process, and will disappear after a few fires.

INSTALLATION

Floor Protection Requirements

The Oakwood must be installed on a non-combustible floor or a non-combustible floor protector. Floor protection, when not using the optional bottom heat shield, must be a minimum 3/4" (19mm) thickness of material having an insulating value equal to or better than 0.84k/in. (The lower the k value, the better the protection.)

Another method for calculating floor protection is in R value. This requirement would be for an R value of 0.89 or higher. (The higher the R value, the better the protection).

In all installations, the area under and around the stove must be protected from falling ash and live coals. *The area under a horizontal run of chimney connector must also be protected, extending two (2) inches beyond the measurement of the horizontal connector.*

Further guidelines for floor protection are as follows:

In the U.S. the floor protector must be completely under the stove, and extending 16" in front of the door opening, 8" to each side and 8" to the back.

In Canada, the floor protection must extend 18" (457mm) in front of the door opening, 8" (203mm) to each side and extend to the wall behind the stove.

Clearances

Clearance is the empty space required between the stove or chimney connector and the nearest combustible surface or object, such as walls, ceilings, floors, or furniture. Clearance distances may only be reduced by using methods approved by either the CAN/CSA B365 standard (Canada) or NFPA 211 (U.S.) Contact your building authority for information if you are interested in reducing clearance distances other than those presented here.

Floor Protection Requirements		Inches	Millimeters
J	Sides- USA /CANADA *	8	203
K	Front- USA /CANADA *	16	457
L	Rear- USA	8	203
L	Rear- CANADA	Wall	Wall

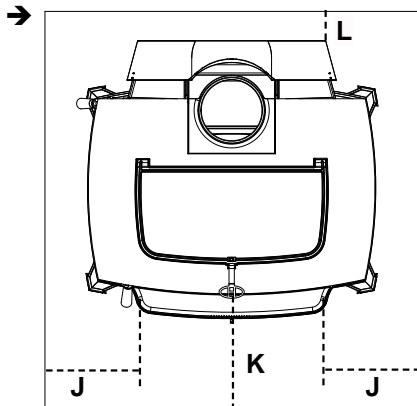

Parallel versus Corner Installations

A parallel installation is one in which the back and sides of the stove are parallel to the walls behind and to the side of the stove. A corner installation is one in which the back of the stove is positioned diagonally across a corner of the room. Each installation requires its own set of clearances.

For parallel installations, the required clearance distances from the stove are: (see next pages for more details, including the use of double walled pipe and optional heat shields)

- 1) to the side wall, 26" (661 mm);
- 2) to the back wall, 28" (712 mm).
- 3) From the flue connector to the wall, 33" (839mm)
- 4) Horizontal pipe to the ceiling, 15"(381 mm).

NOTE: For a vertical chimney connector in a parallel installation the distance of the connector to the side wall must be 32"(813 mm), due to the required side clearance of the stove itself. Fireplace installations must meet these same clearance requirements; specifically follow these guidelines for mantel and trim clearances.

For corner installations, the clearance distances from the stove are 24"(609 mm) from each corner of the stove measured straight back to the nearest combustible material, and 32" (813 mm) from the chimney connector to the walls.

From the front of the stove, clearance to combustible materials such as furniture, curtains, fuel, etc., is: 48"(1220 mm) in the U.S. and 60"(1524 mm) in Canada.

Alternate floor protector dimension may be used as long as they satisfy the measurement requirements shown above.

Minimum size floor protection for a corner installation hearth pad is 54" x 54" (USA ONLY).

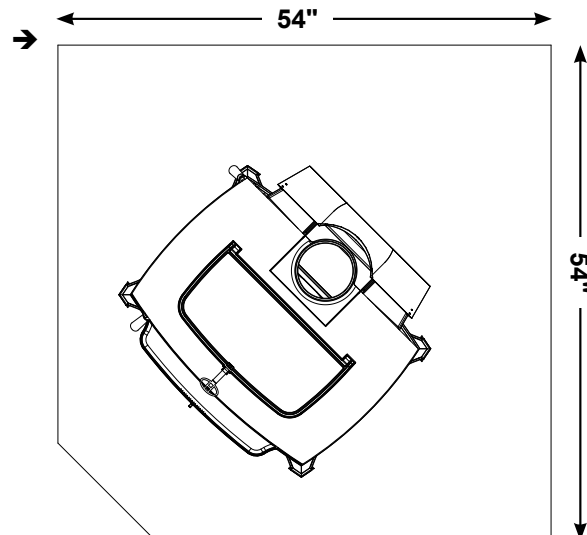

INSTALLATION/CLEARANCES

Single Wall Pipe - Top Vent - Parallel Installation

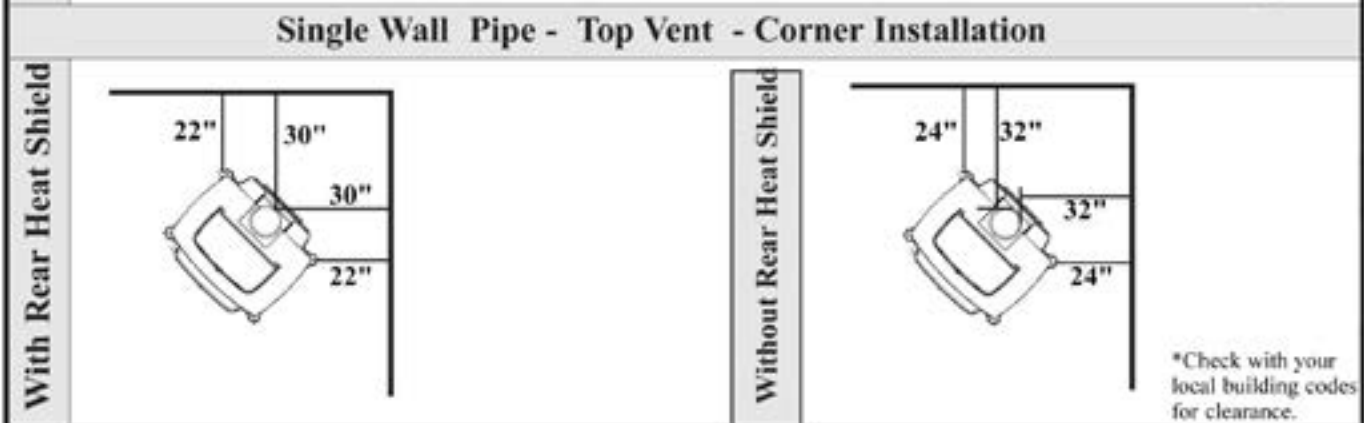
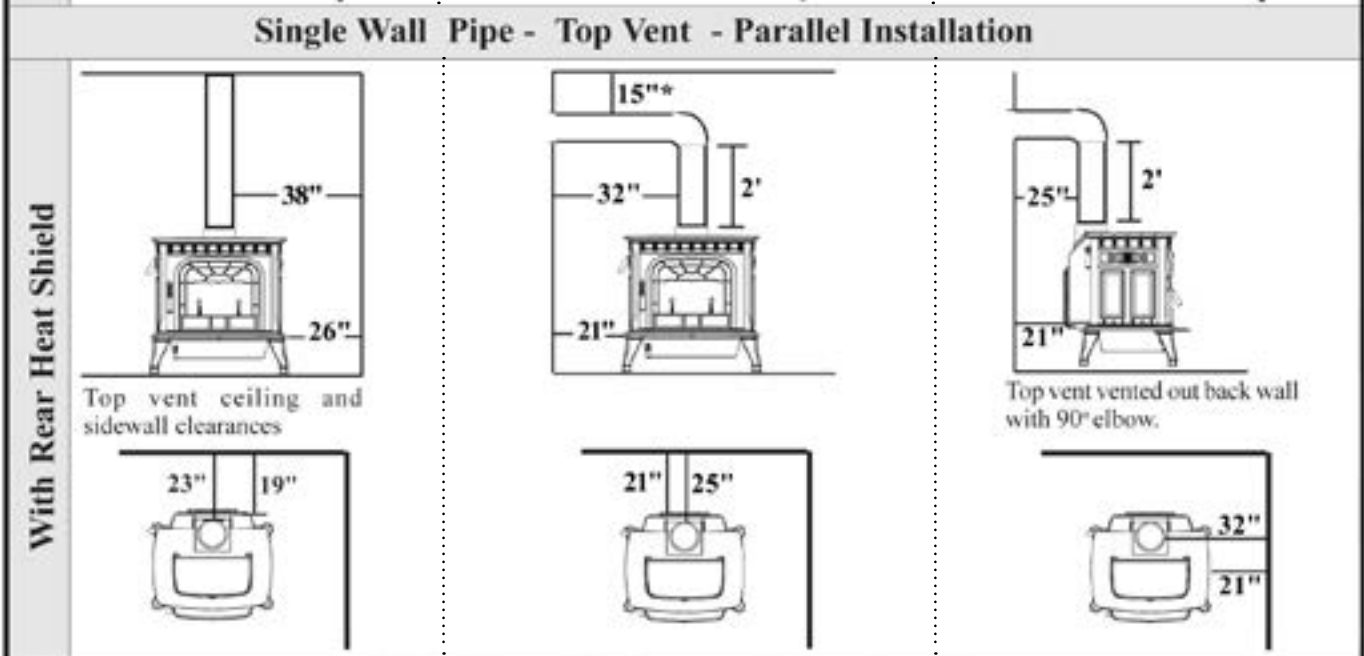
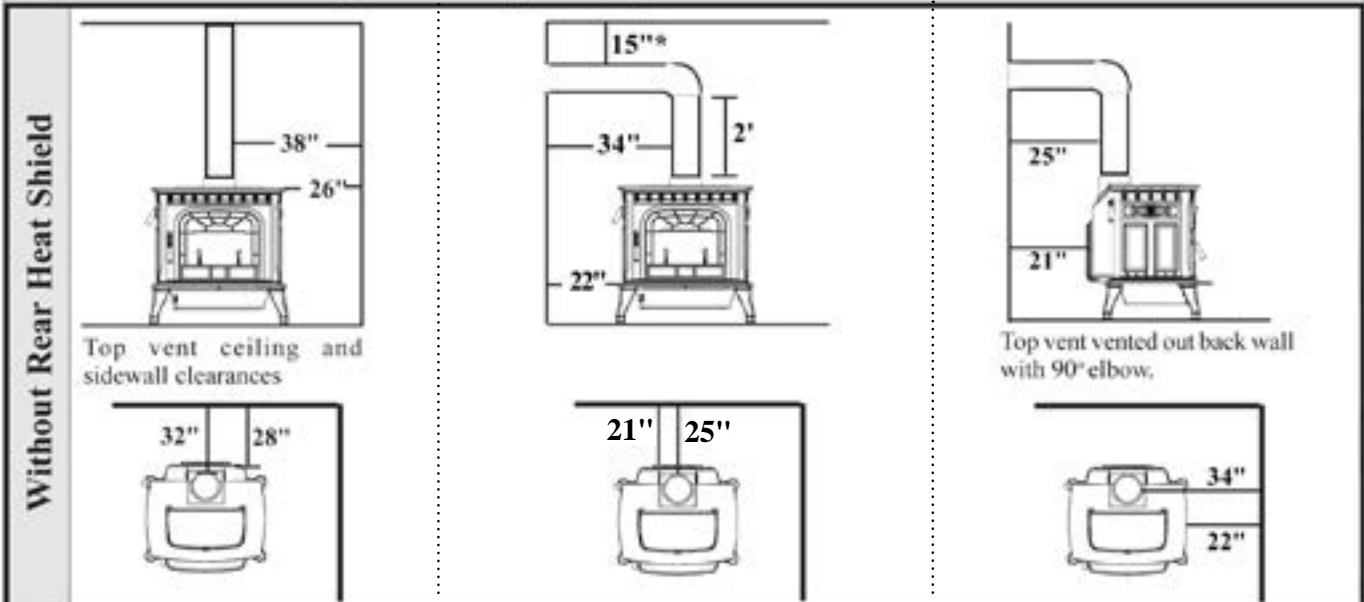

See NFPA 211 for more installation clearance reductions when using USM wall protection, etc.

INSTALLATION/CLEARANCES

Single Wall Pipe - Rear Vent - Parallel Installation

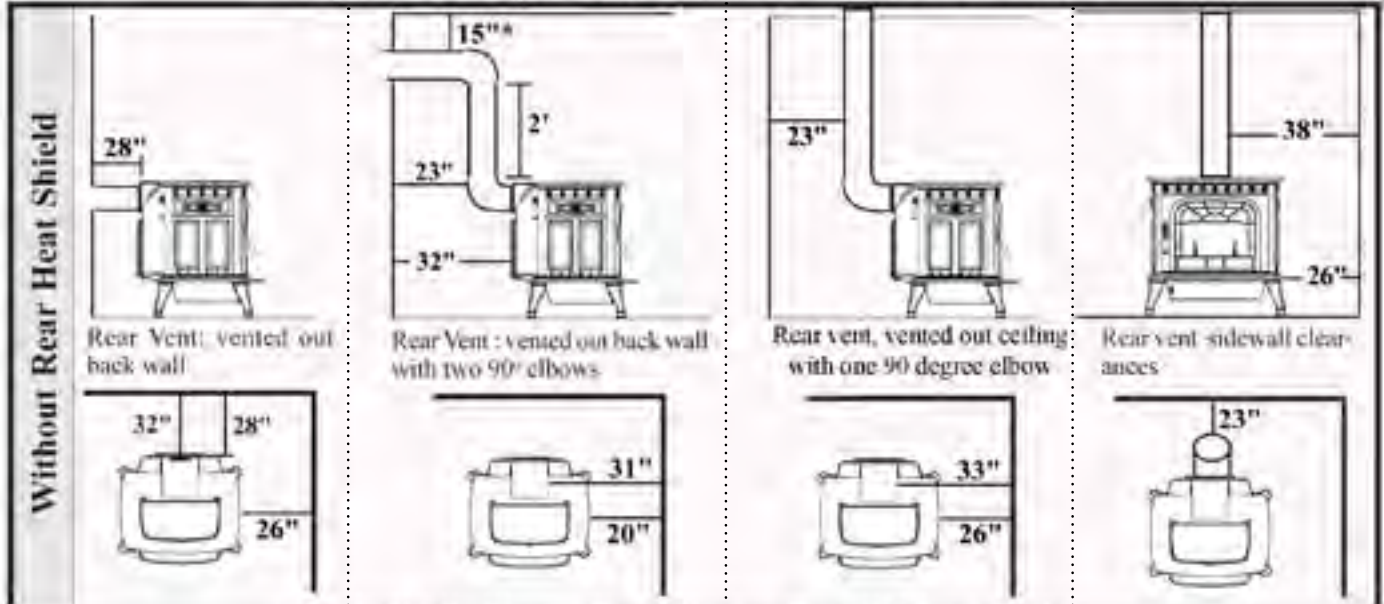

Single Wall Pipe - Rear Vent - Parallel Installation

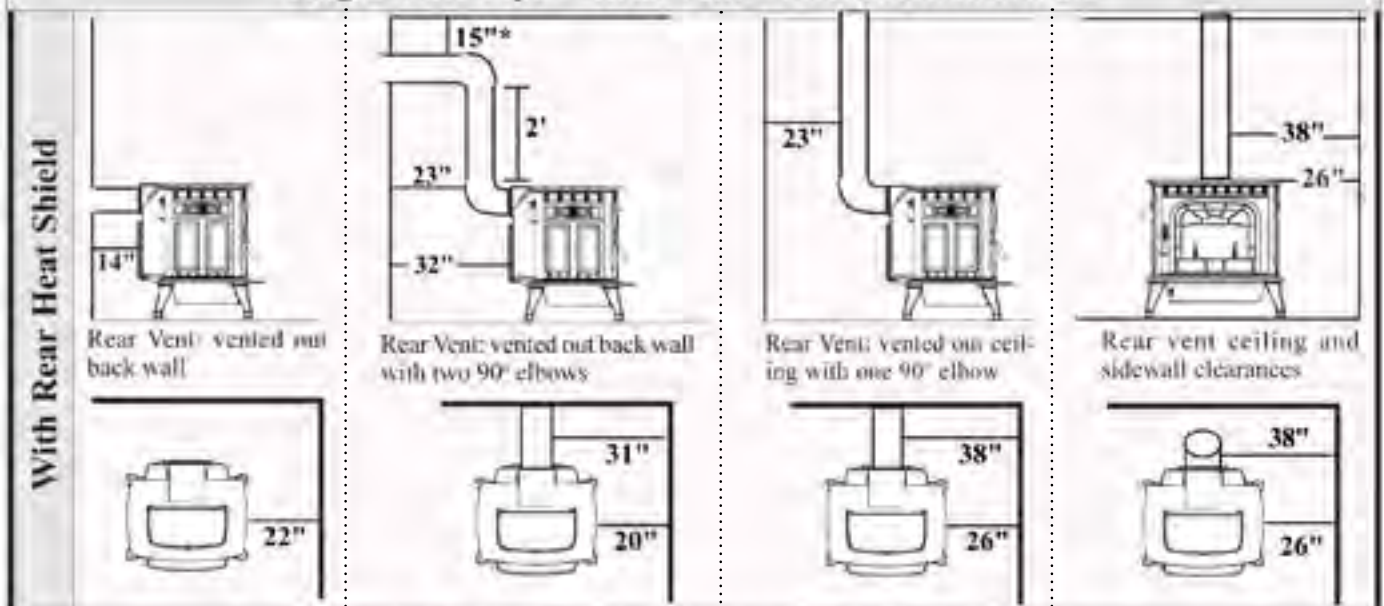

Single Wall Pipe - Rear Vent - Corner Installation



*Check with your local building codes for clearance.

See NFPA 211 for more installation clearance reductions when using USM wall protection, etc.

INSTALLATION/CLEARANCES

Parallel Installation with Double Wall Pipe and optional shielding

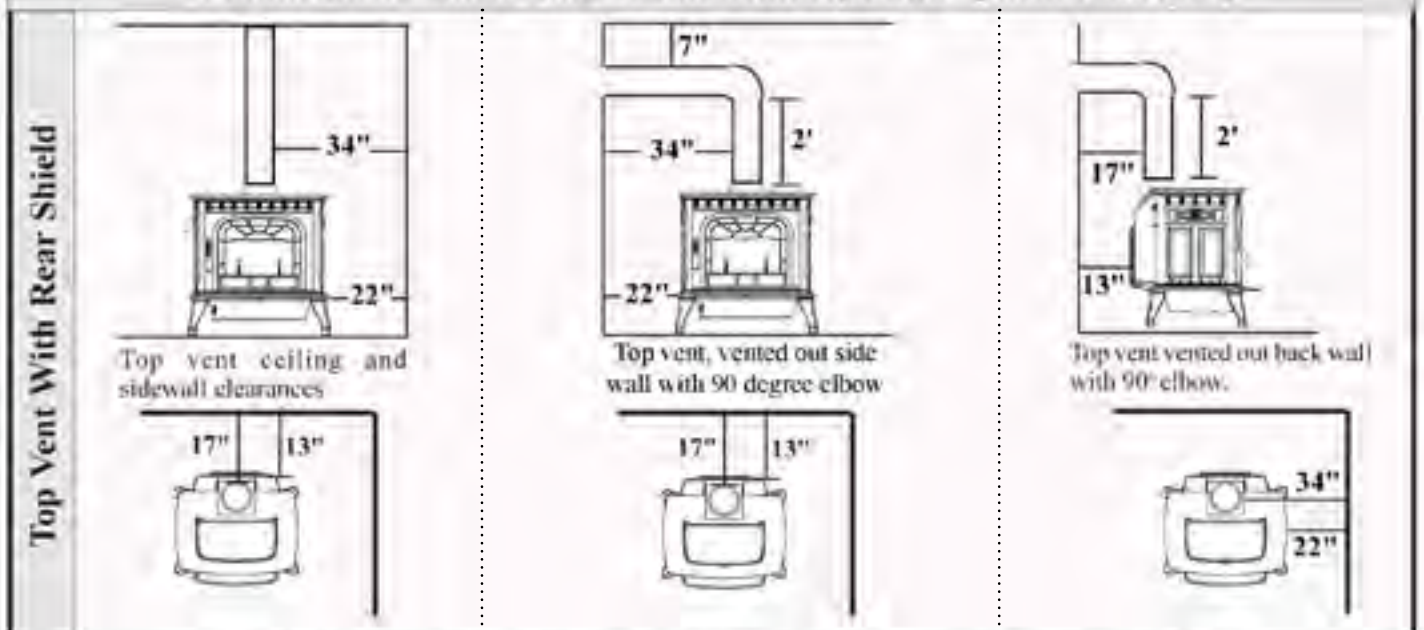

Parallel Installation with Double Wall Pipe and optional shielding

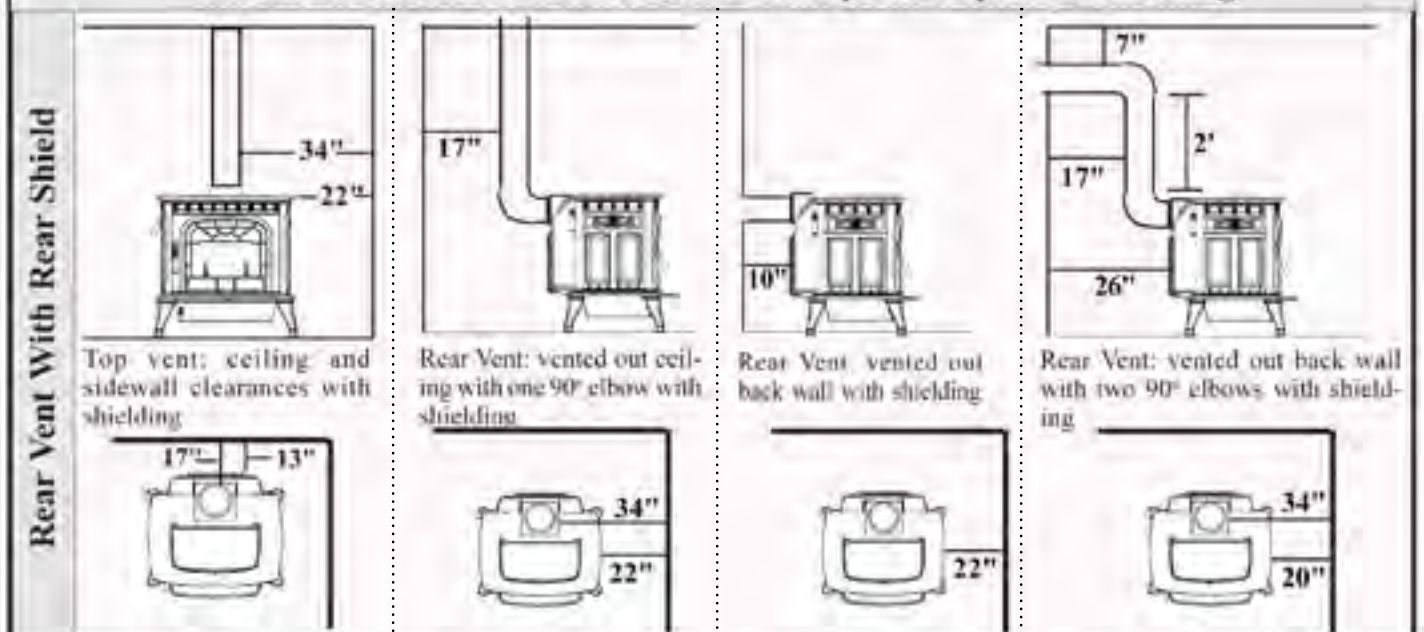

Corner Installation with Double Wall Pipe and optional shielding

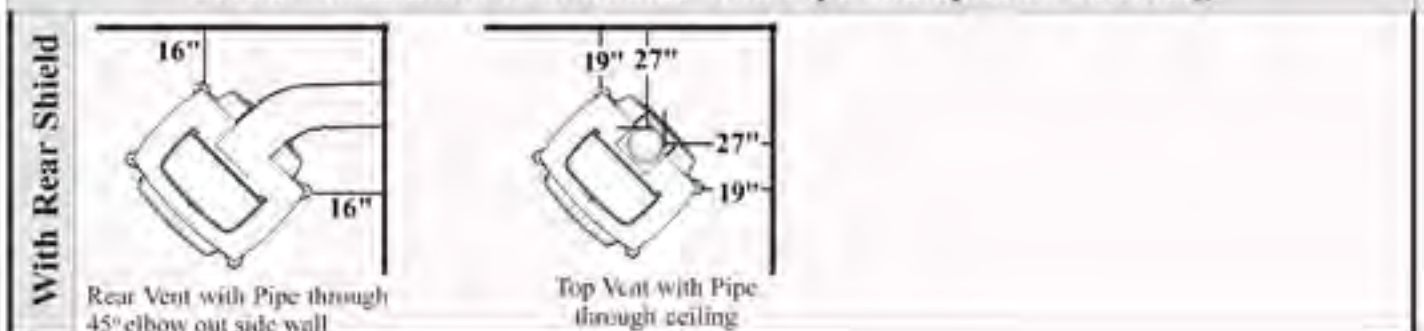

See NFPA 211 for more installation clearance reductions when using USM wall protection, etc.

INSTALLATION/CLEARANCES

Fireplace Insert Installation - Rear Flue - 6" Single Wall Pipe

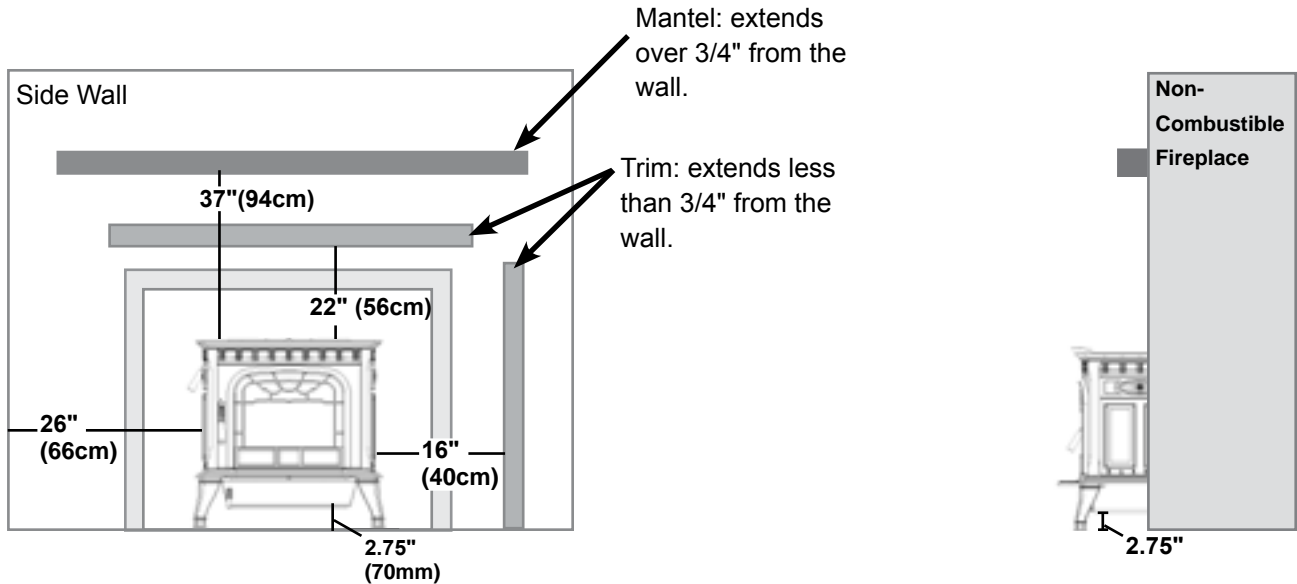

NOTICE: Not for use in factory built fireplaces with hearth weight limitations.

The Oakwood should not be installed into a factory built fireplace unless the hearth area is designed to take the maximum weight of the stove. The Oakwood, loaded with wood weighs approximately 500 pounds (250kg).

If the fireplace floor can hold the 500 lb. (250 kg) Oakwood, the stove should only be placed into the fireplace opening to the point that operation of the damper bypass control and the top load door operation is not compromised or unsafe. (See above illustration.)

Installing in front of a fireplace with Mantel

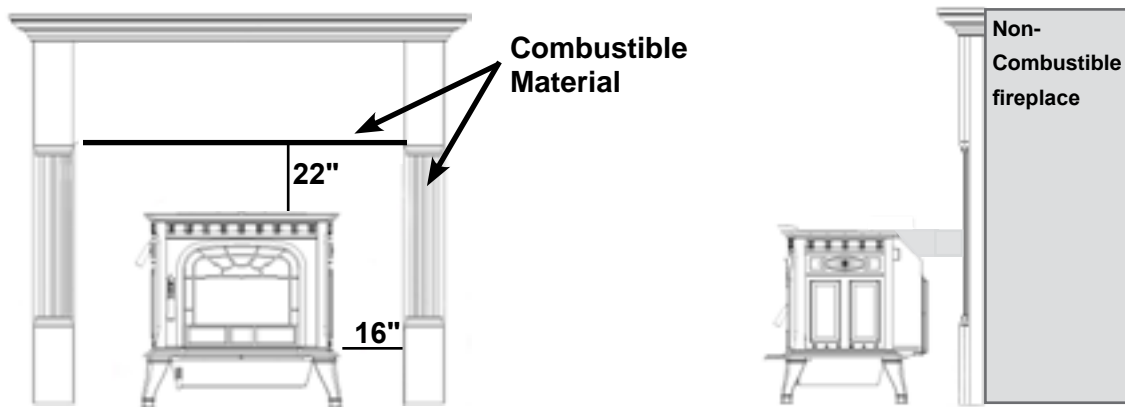

VENTING

Chimney Connectors and Chimneys

Draft

Draft is widely misunderstood. It is important that you, the stove operator, realize that draft is a variable *effect*, not a given quantity. Stoves and chimneys do not *have* draft, yet draft is the key to your stove's performance.

Draft is a *force*, produced by an operating stove and the chimney to which it is attached. It is created by hot gases rising up the chimney, creating a pressure difference between the inside of your home and the outside air. It continually moves fresh combustion air into the stove, and hot exhaust gases out of the stove; without this constant flow, the fire will go out.

Other factors, such as barometric pressure, winds, the airtightness of the home, the total inside chimney volume, chimney height and the presence of venting devices such as exhaust fans also play a role in maintaining an adequate draft. Low barometric pressures, super insulated homes and exhaust fans can reduce draft; winds can play havoc with draft; and too large or too small a chimney volume can cause reduced draft due to the excessive cooling or not enough room to vent exhaust gases. Introducing outside air directly to the stove may help remedy a low draft problem. Some signs of inadequate draft are smoking, odor, difficulty in maintaining the fire, and low heat output. Overdraft can be caused by a very tall chimney even if it is the recommended size, and can cause overfiring of your stove. Signs of an overdraft include rapid fuel consumption, inability to slow the fire, and parts of the stove or chimney connector glowing red. It is important that you follow the chimney guidelines in this manual, including size, type, and height to avoid draft problems.

When installed and operated according to this manual, the Oakwood will produce enough hot gases to keep the chimney warm so that adequate draft is maintained throughout the burn cycle.

Chimney Connectors

In general, following these guidelines will ensure compliance with all national and provincial codes; prior to beginning your installation, check with your local building code official to check on additional local regulations which may influence the design and placement of your venting system.

The Harman Oakwood may be installed with a minimum (.6 mm) 24 gauge chimney connector pipe. The size of the connector should correspond to the size of the flue collar opening. Do not use makeshift compromises. No part of the chimney connector may pass through an attic or roof space, closet or other concealed space, or through a floor or ceiling. Whenever possible, avoid passing the connector

through a combustible wall; if you must, use an approved wall pass-through, described later in this section.

Assemble the connector beginning at the flue collar, with the crimped ends pointing towards the stove (to keep debris and creosote flakes inside the system). Each joint, including the one to the stove's flue collar and the one to the chimney itself should be secured with at least three sheet metal screws. Screws may be a maximum of 3 inches apart. A 1-1/4" (30 mm) overlap is required at each joint, including the flue collar attachment. No more than two 90 degree elbows should be used, and the total length of connector should not exceed 10 feet (3 m). All horizontal runs of connector must have a minimum upward slope of 1/4"(6 mm) per foot (20 mm per meter).

Chimney connector should correspond to the size of the flue collar opening. Do not use makeshift compromises. No part of the chimney connector may pass through an attic or roof cemented in place with refractory cement.

Wall Pass-throughs

Occasionally it is necessary to pass the chimney connector through a combustible wall to reach the chimney. Depending on your local building codes, and the pertinent provincial or national codes, there are several choices for accomplishing this safely. Before beginning your installation, contact local officials, and also the chimney connector and chimney manufacturer for specific requirements.

Canada. Three methods are approved by the Canadian Standards Association. The diagram on the next page shows one method requiring an 18"(450 mm) air space between the connector and the wall. It allows use of one or two covers as described in the diagram. The two other methods are described in detail in the current issue of CAN/CSA B365, the national standard.

United States In the U.S., the national code is NFPA 211. While many localities adopt this standard, be sure to check with local authorities before beginning your installation.

The NFPA (National Fire Protection Agency) permits four methods for passing through a combustible wall. A commonly used method to pass through a wall directly to a masonry chimney is to clear a minimum 12"(300 mm) around the entire chimney connector, and fill it with brick masonry which is at least 3.5"(90 mm) thick. A fireclay liner, minimum 3/8" (9 mm) wall thickness must run through the brick wall to the chimney liner (but not beyond the inner surface of the liner). It must be cemented in place with refractory cement. This method is illustrated on the next page. For details on the other three options, refer to the most recent edition of the NFPA 211 code.

VENTING

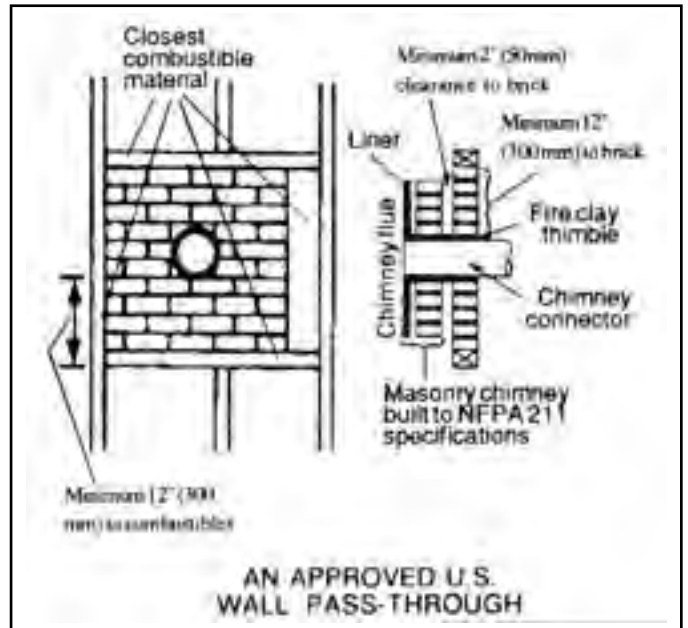
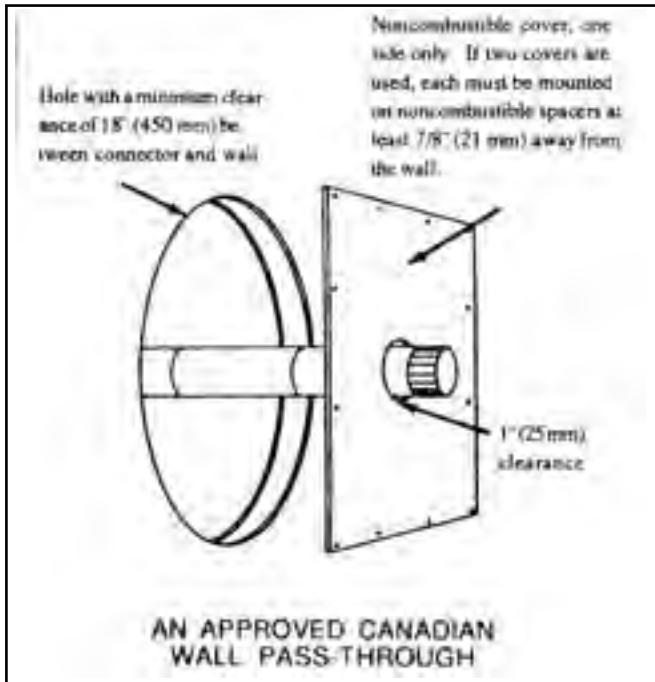

The Chimney

The Oakwood must be installed into a chimney approved for use with solid-fuel appliances. In the U.S., the Oakwood must be connected to (1) a prefabricated chimney complying with the requirements for Type HT chimneys in the Standard for Chimneys, Factory-Built, Residential Type and Building Heating Appliances, UL 103, or (2) a code-approved masonry chimney with a tile flue liner. In Canada, the Oakwood is listed for use with prefabricated chimneys tested and listed to the high temperature (650 degrees C) chimney standard, ULC S-629, or with a code approved masonry chimney.

The minimum recommended height for any chimney is 16 ft (4.8 m) above the flue collar height. For non-mobile home installations, a round flue (either masonry or approved prefabricated), of either 6" (150 mm), 7" (180 mm) or 8" (200 mm) may be used. For square or rectangular masonry chimneys, nominal sizes of 8" x 8" or 8" x 12" (200 mm x 200 mm, 200 mm x 300 mm) may be used.

Codes require that solid-fuel chimneys extend 3 ft (0.9 m) above the point at which they exit from the roof. The chimney must extend 2 ft (6 m) above the highest point within a 10 ft (3 m) radius of the top of the chimney. Thus, the 2 foot, 3 foot, 10 foot rule; "The top of the chimney must be a minimum of **3 feet** above where it exits the roof, and **2 feet** higher than anything within **10 feet**."

Do not connect this unit to a chimney flue servicing another appliance.

NOTE: The restriction of not venting more than one appliance to the same flue applies to the U.S. specifically. While it is not recommended that you use the same chimney for more than one appliance, in Canada certain exceptions may be made. Be sure to contact your building code inspection official to see if this option is allowed in your area, and to find out the specific requirements for such an installation.

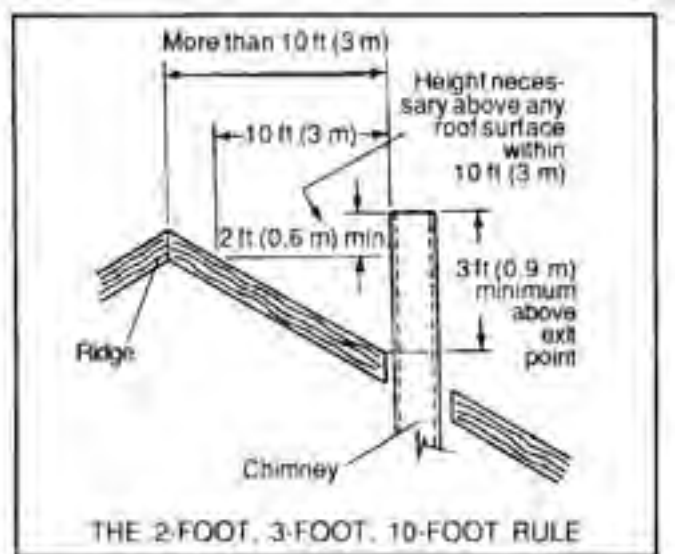

VENTING

Existing Masonry Chimneys

If you plan on using an existing masonry chimney, have it thoroughly inspected and cleaned. Any faults which make the chimney unsafe and unusable must be repaired prior to use. These can include improper height, structural defects, blockages, inadequate clearance to combustibles, unsealed openings into other rooms of the house, signs of creosote or smoke leakage, a loose or absent clean-out door, or absence of a liner.

Do not connect to any air distribution duct or system

Venting to a Masonry Chimney

When connecting to a masonry chimney, several provisions are standard. First, whether the chimney connector is vented to the chimney through a thimble or a breech pipe, neither must pass beyond the inner surface of the chimney liner, and both must be firmly cemented in place with refractory cement. (A thimble is a masonry pipe which is inserted through the chimney wall, and is frequently the preferred method; a breech pipe is a piece of steel pipe used the same way.) In Canada, a breech pipe has ridges or protrusions to lock it firmly into the refractory cement. In either case, the chimney connector vents to the chimney through the thimble or breech pipe.

Using a thimble, the connector slides completely inside the masonry to the inner edge of the flue liner, and may be easily removed for chimney and connector inspection. A breech pipe must extend at least 2" (50 mm) into the room, so the connector can be attached with sheetmetal screws.

Venting to a Masonry Fireplace Chimney

In some situations, a code compliant chimney originally used for a masonry fireplace may be used to install your Oakwood. In addition to the requirements found in the previous paragraphs, it is important to be aware that all clearances must be met, including those from the chimney connector to combustibles — 18" (360 mm) to sides and 18" (450 mm) to ceiling. Do not forget to include floor protection in your plans. (See Clearances and Floor Protection in this section.) Since many fireplaces have exposed wooden mantels and trim, pay special attention to the clearances necessary to these materials.

If your fireplace chimney is behind a combustible wall, you must use an approved wall pass-through system to gain access to the masonry chimney. The chimney connector must enter the chimney at a place where it is

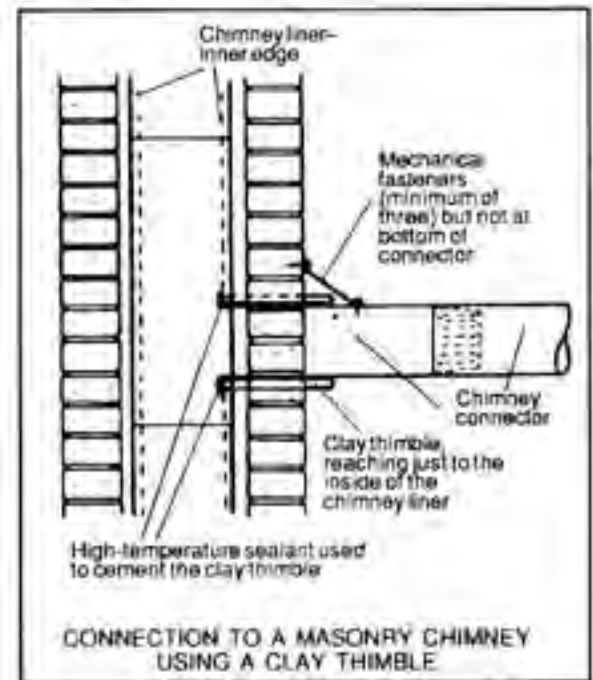

lined, and the fireplace must be made inoperable. For example, you might remove the damper, replacing it with a secure, airtight, noncombustible seal, like a steel plate (removable for inspection); this also satisfies the requirement that no room air must be allowed to enter the chimney. Kaowool, mineral wool or equivalent non-combustible insulation may be installed on top of the plate to help minimize condensation. (Install a rain cap on the top of the chimney).

Installing to a Prefabricated Chimney

When venting your Oakwood using a prefabricated chimney, be sure to contact local building code authorities, and to follow the manufacturer's instructions *exactly*. Use only the manufacturer's parts; do not use makeshift installation techniques. All prefabricated chimneys must be tested to either the U.S. or Canadian high-temperature standards, UL 103 or ULC-629.

VENTING

Warning: Do not install in sleeping room.

Caution: Always wear fire-resistant gloves to operate the stove. The air control is hot while in operation.

The Harman Oakwood was tested with fuel door open and closed. Keep door closed for normal operating conditions. If you operate with doors open, open the by-pass and put a screen over the opening.

Do not burn any fuel other than wood, such as charcoal, which can cause increased carbon monoxide production or overfiring. Never use highly volatile substances in your stove, such as gasoline, which could cause an explosion.

When solid fuels are burned completely, they produce water and carbon dioxide. However, in long slow burns, a substantial amount of carbon monoxide may be produced. If allowed to build up, carbon monoxide (which is odorless) can prove fatally poisonous. Proper ventilation and draft will prevent this from happening. If you smell smoke, turn up the air control lever setting, and thoroughly ventilate your dwelling. During future burns, be careful not to overload the stove with fuel, so you will not be tempted to constantly operate at a low air control setting.

Other causes of poor ventilation or draft are icing, exhaust fans, a blocked outside air inlet, and room air starvation. If your stove is sluggish and you get occasional odor, check these possibilities and increase the air flow in your home.

VENTING

Standard Ceiling Installation with Factory Built Chimney

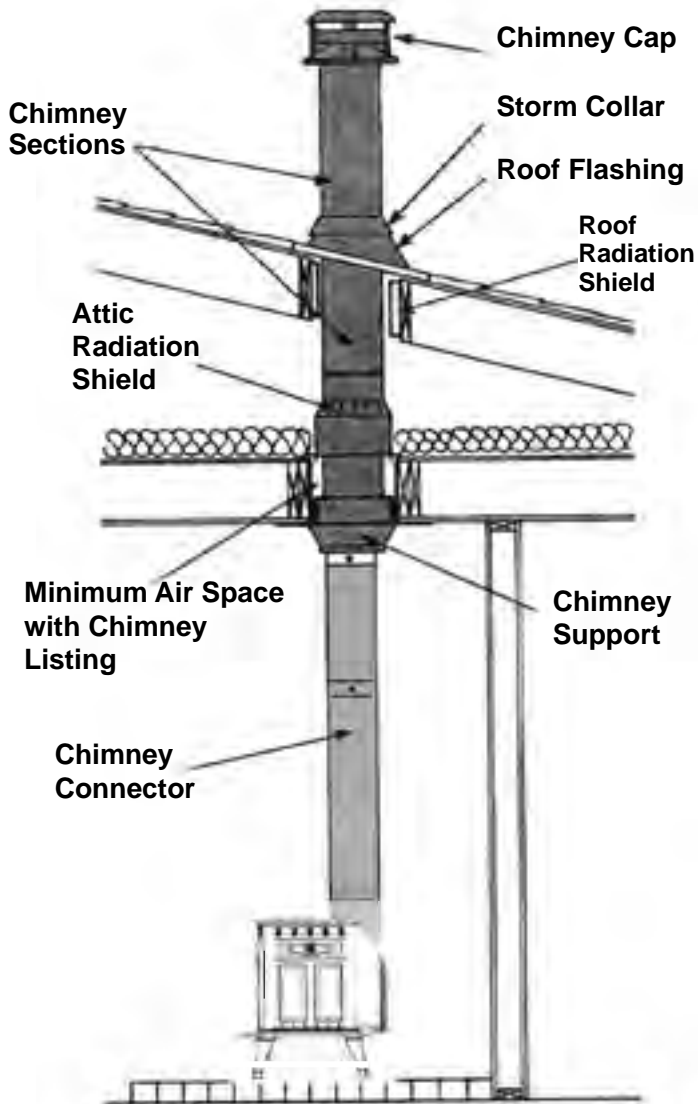

Cathedral Ceiling Installation with Factory Built Chimney

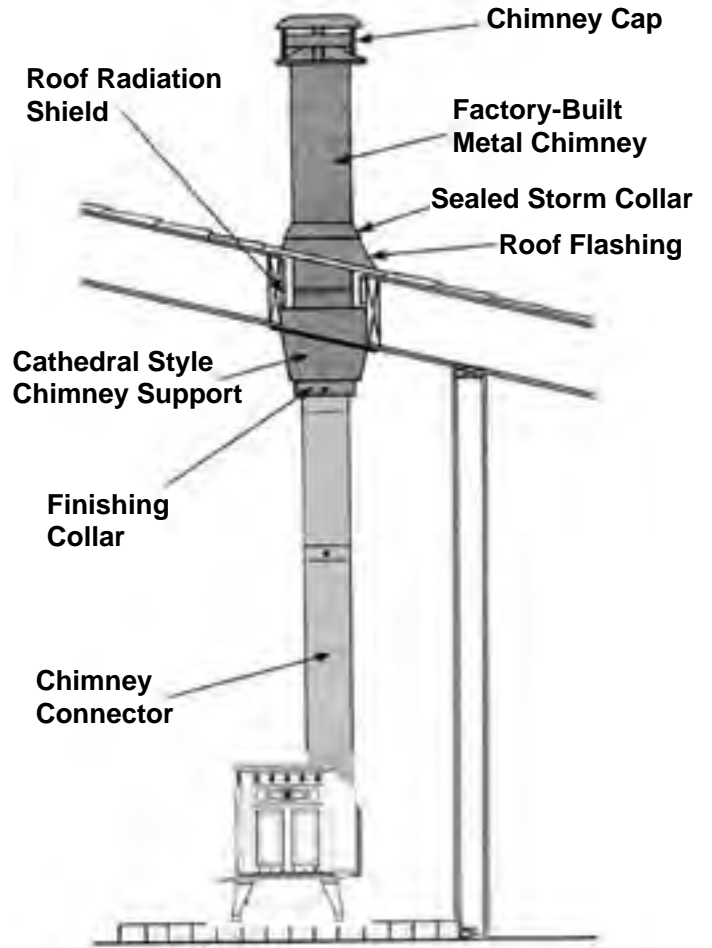

VENTING

Chimney Breach Fireplace Conversion with Non-Combustible Wall

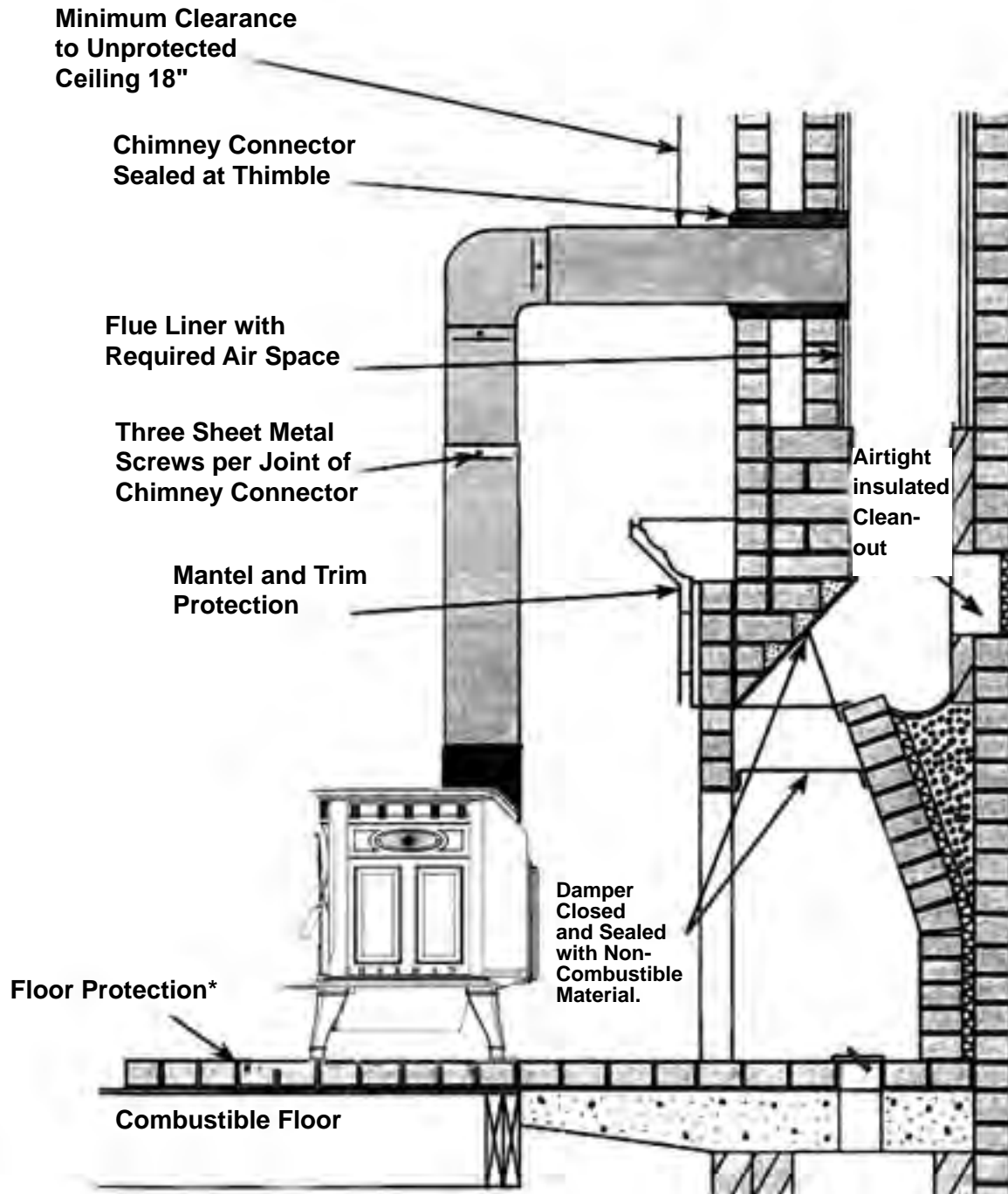

* Floor Protection in Accordance with Solid Fuel Appliance Listing

VENTING

Oakwood to Flue Fireplace Conversion (Minimum NFPA 211 Liner Connection)

Flue Liner with Required Air Space

Stainless Steel Chimney Connector Must Extend to Flue Liner

Minimum 8" Masonry Thickness in Front of Smoke Chamber

Use Damper Adapter or Seal with Non-Combustible Material

Damper Plate is Removed or Fastened in Open Position

Listed Fireplace Trim Protection for Reduced Clearance

Floor Protection*

Combustible Floor

Airtight insulated Clean-Out

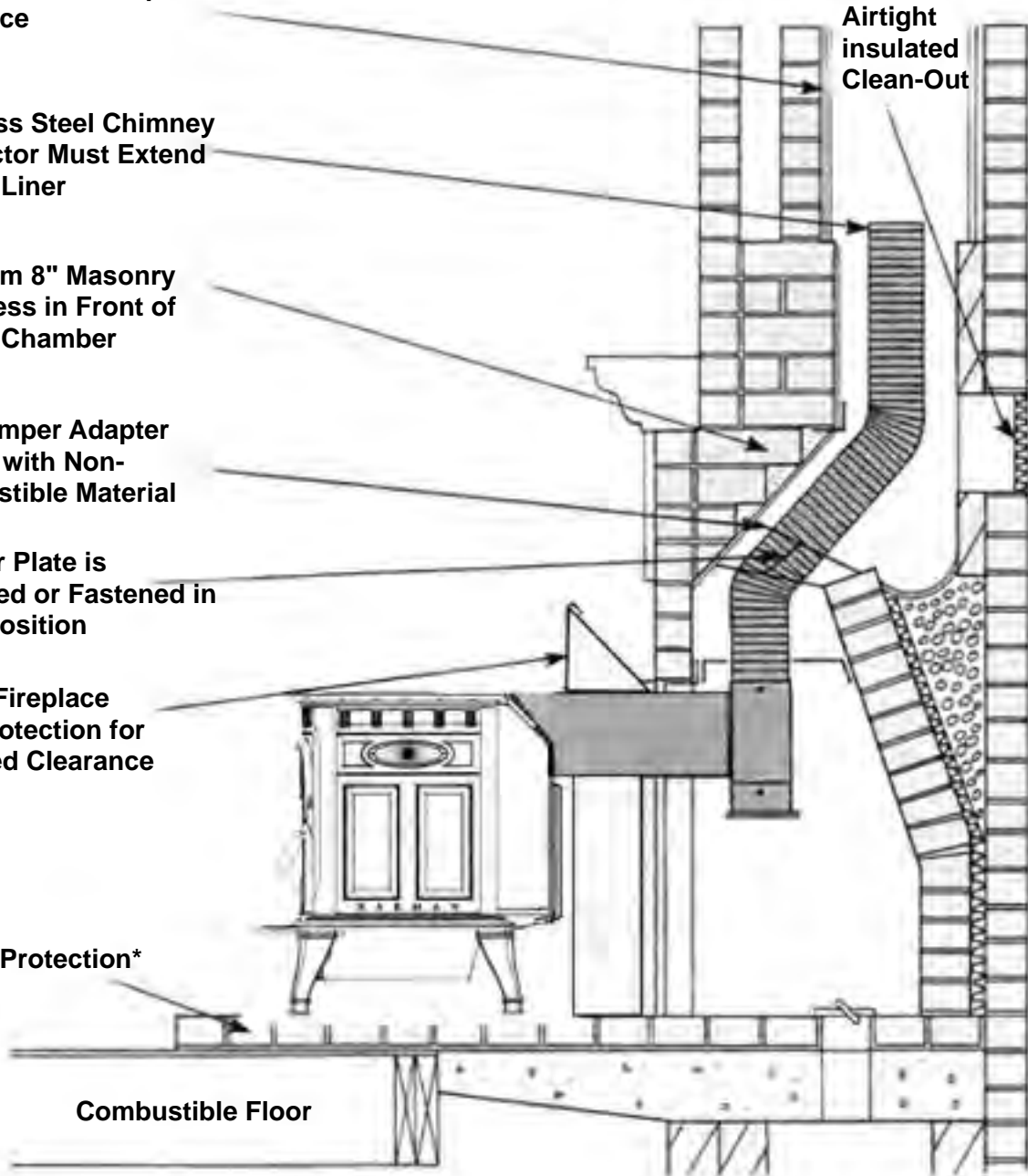

*Floor Protection in Accordance with Solid Fuel Appliance Listing

VENTING

Full Relining Fireplace Conversion: Freestanding Appliance

UL1777 Stainless Steel Liner System or
Other approved lining system

Follow liner manufacturer's
instructions on insulation and
support

UL1777 Insulated Stainless
Steel Flex Liner or Other
Approved Lining System in
Offsets.

Listed Fireplace Trim Protection
for Reduced Clearance

Damper Plate Removed or
Fastened in Open Position

Use Damper Adapter
or Seal with Non-
Combustible Material

Floor Protection*

Combustible Floor

*Floor Protection in Accordance with Solid Fuel Appliance Listing

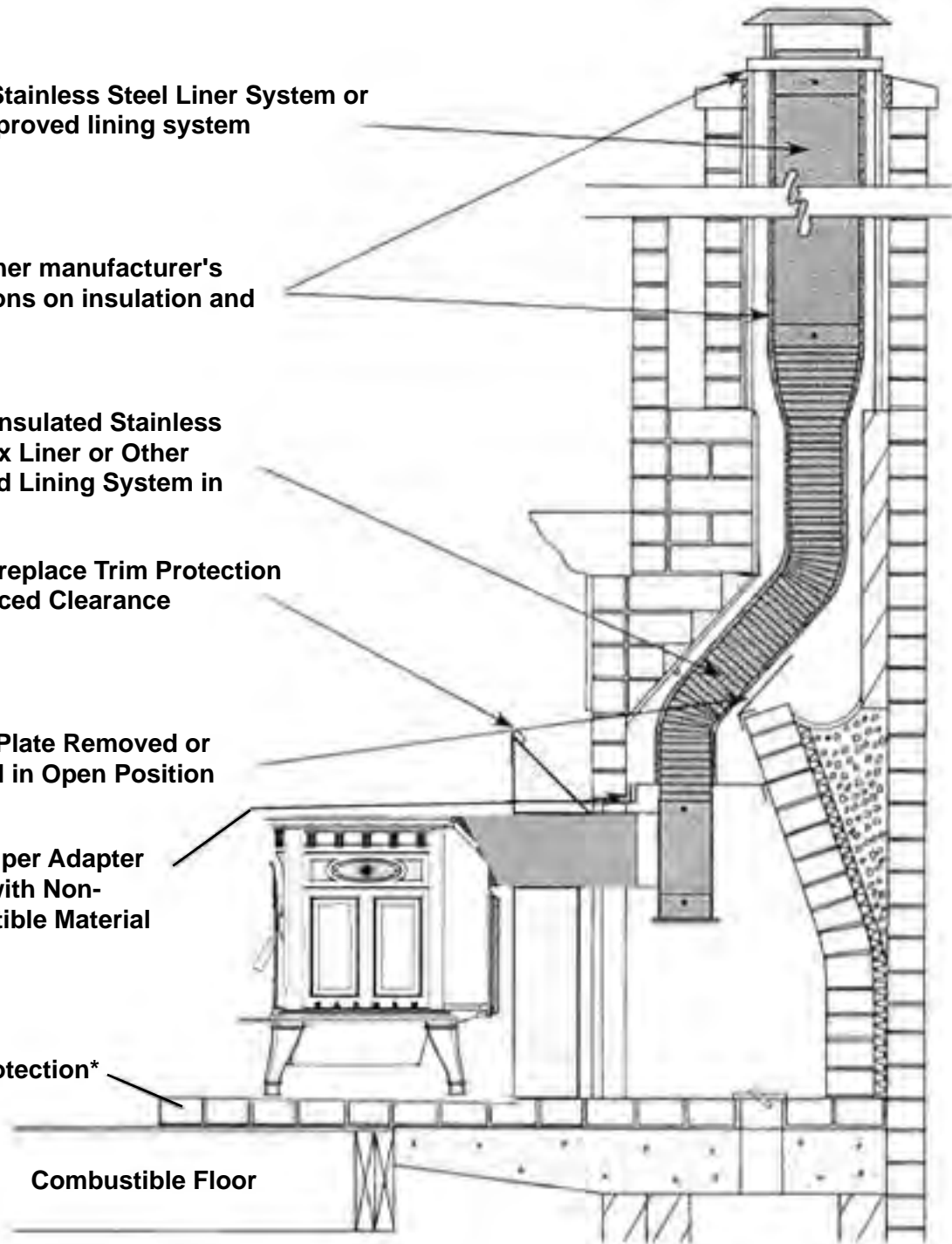

VENTING

Chimney Breach Fireplace Conversion with Combustible Wall

Minimum Clearance from
Chimney Connector to
Unprotected Ceiling

15"***

Flue Liner with Required Air Space

Listed or Approved Thimble Assembly

1" Clearance for
Complexity Exterior
Chimney
or 2" Clearance for
Interior Chimney and 2"
Clearance for NFPA 211-
Type Approved Thimbles

Combustible
Wall

Sheetrock

Airtight
insulated
Clean-out

Mantel & Trim
Protection

Damper Closed
and Sealed with
Non-Combustible
Material.

Floor Protection*

Combustible Floor

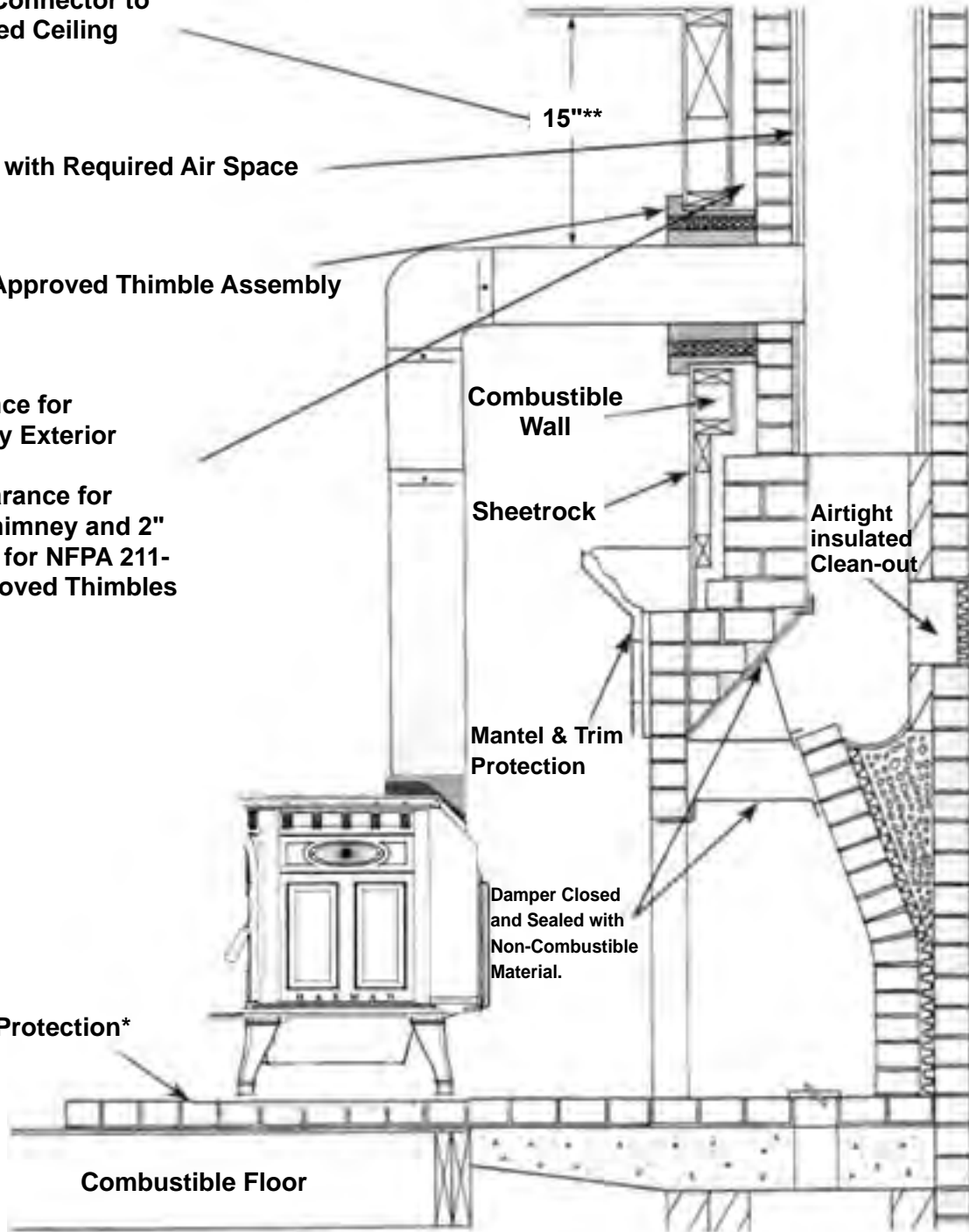

* Floor Protection in Accordance with Solid Fuel Appliance Listing

** Check with your local building codes for clearance.

MAINTENANCE

Seasonal cleaning

At least once per year, the stove, venting connectors and chimney should be thoroughly cleaned. If the areas are found to have an excessive build up of ash or creosote, it is recommended to increase the frequency of the cleaning. This will extend the life of the appliance and its components. A vacuum specifically designed for ash is preferred, however a standard "Shop-Vac" with a HEPA filter may also work just fine.

During cleaning, caution must be taken not to damage the white / gray colored ceramic combustion package in the rear of the firebox. When using a brush in the chimney or venting connector, the by-pass damper should be placed in the open position to help prevent ash, creosote or other debris from falling down onto and around the combustion package. This also protects the top of the combustion package from tool or brush damage and diverts most of the removed materials into the firebox for easy clean-up and removal. Once the venting system has been cleaned, remove the first section of connector pipe from the appliance flue collar. Carefully vacuum the ash and debris from around the sides and top of the combustion package.

The ramp brick must be removed to allow vacuum access for cleaning the front portion of the combustion package.

Always use caution when refueling or when vacuuming the firebox and combustion package. Some users have damaged their combustion package with vacuum cleaner tools, and fire pokers.

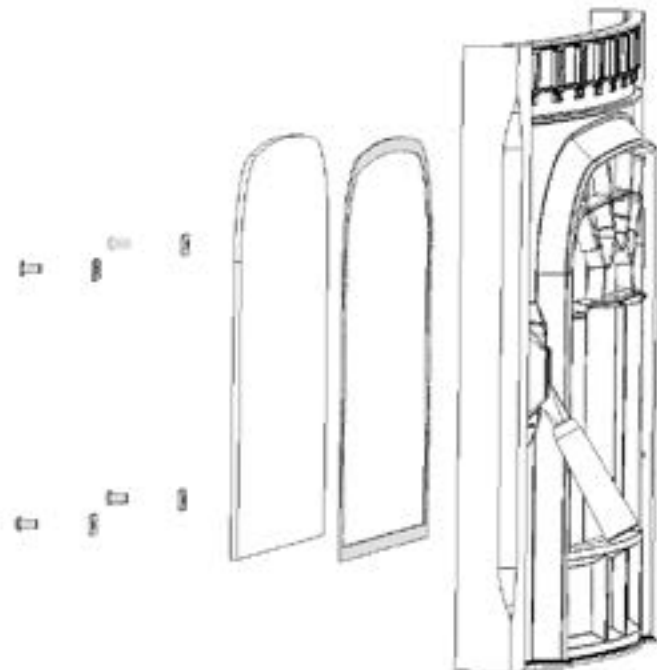

The Stove

Surface

The stove's exterior surface should be dusted periodically with a soft cloth. For more thorough cleaning, wait until the stove is cool before using a damp cloth to clean any blemishes.

Controls

To avoid a rust build-up on the inner surfaces of the controls, work the controls back and forth several times, during the summer, or any prolonged period when you are not using your stove.

The Fire Chamber

The inside of the fire chamber should be examined for damage to the refractory lining material, grates, and casting. If any bricks have been damaged, replace them with Harman replacement parts.

Glass - Replacement

If the stove's glass is cracked or broken, you must replace it before operating your stove. Remove pieces carefully. Replace glass only with Harman replacement glass; do not use substitutes.

To replace the glass panel, you will need to remove the door. To do this, open the door, lift it straight up and place it on a soft surface, or door stand that is an optional feature with the Oakwood.

Carefully remove damaged glass, gasket material, and hold down clips (set aside).

Referring to the diagram, note how the various components of the door system fit together. Lay the load door face down on the soft surface, and install the self adhesive 1/4" gasket material around the front face of the glass. Note: this glass has a special IR coating on one side. This coating must be to the **outside** of the stove. The coated side has a label on it. The coated side will also show a resistance reading.

Set the glass panel and gasket gently onto the door. Install the hold down clips and tighten with bolts as shown. Reinstall door on stove.

Glass - Cleaning

Occasionally, it will be necessary to clean accumulated ash from the glass surface; allowing this ash to remain on the glass for long periods can result in "etching" due to the acidity of the ash. The creosote which accumulates on the glass should burn off during your hot fires.

Never clean the glass while it is hot, and do *not* use abrasive substances. Wash the surface with cool water, and rinse thoroughly. You may wish to use a non-abrasive cleaner specifically designed for use on stove glass. In any case, dry thoroughly before relighting your stove.

MAINTENANCE

Gaskets

Gaskets are used at strategic positions when building the Harman Oakwood for controlling the path that incoming and outgoing air and gases take through the stove. You must check these gaskets from time to time, and replace them when necessary. The gaskets are made of fiberglass of different sizes (obtainable from your Harman dealer) and some are fixed in place with a high temperature stove gasket cement. To change a gasket, first remove the worn fiberglass and clean the area with a wire brush. Also clean any other surfaces that come into contact with the gasket. Place a small bead of cement in the area under the gasket if required, then press new gasket material into the channel; do not overlap the ends. Seat the gasket firmly by applying pressure when possible; for example, after changing the door gasket, close the door. Allow the cement to dry before using your stove.

Gaskets are located:

- On the doors to provide airtight closure.
- Between the damper and the damper frame.
- On sides between top and bottom plates.
- Inner front to air wash.
- Rear cover
- Rear housing

Damper Ramp Adjustment

After the stove has been in operation for awhile, the damper gasket may compress and allow the damper handle to move from the open to the closed position without the added ramp tension needed to keep the damper held in the closed position.

To adjust the ramp, the stove MUST be allowed to go out and cool down.

- After the stove has cooled off, remove the stove pipe from the stove collar and close the damper.
- Using a flashlight, look into the collar. About midpoint of the damper plate on the backside you will see the adjustment bolt for the ramp tension.
- You will need (2) 7/16 " wrenches. Use one to hold the bolt still while using the other to loosen the nut.
- Turn the bolt inward (clockwise facing the head) approximately 1/4 turn and retighten the locknut.
- Now open and close the damper to check for proper tension on the damper lever while moving into the closed direction.
- If the tension is incorrect, readjust the bolt.

The Chimney System

Creosote

When wood is burned slowly, it produces tar and other organic vapors, as well as soot, which combine with expelled moisture to form creosote. The creosote vapors condense in the relatively cool chimney flue (associated with a slow burning fire). As a result, creosote accumulates on the flue lining. When ignited, this creosote can result in an extremely hot fire.

The FireDome on the Oakwood cuts creosote to almost nothing when properly burned with dry seasoned wood.

The chimney should be inspected at least once every two months during the heating season to see if any creosote build-up has occurred. Checking your chimney and chimney connector more frequently, especially while you are getting used to your stove, is recommended. To inspect this system, let the stove cool. Using a flashlight and mirror, check the interior of the chimney connector, and the chimney itself. If a significant layer of creosote or soot has accumulated (1/8" or 3 mm) it should be removed to reduce the risk of a chimney fire.

To clean deposits from the surface of the connector, use a stiff wire brush after dismantling the connector assembly. To clean the chimney, use a specially designed brush sized to fit your particular flue opening, or call an established chimney cleaning service.

At the end of each heating season, perform a thorough examination of your chimney system, and have it cleaned and repaired as necessary.

Cooking Grill

The Oakwood offers a unique stainless steel cooking grill that fits in the top load opening and can easily be taken in and out of the stove. Nothing beats the taste when cooking over a wood fire.

Note: Always wear heat resistant gloves when opening the top loading door. The metal handle will be hot and may cause serious harm.

Warming Shelves

Cast Iron Warming Shelves are available to accent your Oakwood and are attached by steel braces.

Rear Heat Shield

The rear heat shield will allow you to install your Oakwood closer to the wall. Please note there are two different shields based on whether the unit is rear or top vented.

Bottom Heat Shield

The bottom heat shield allows the Oakwood to be installed on a combustible floor using any non-combustible floor protector with no specific insulating value. **Note: A floor protector is always needed.**

Cozy Screen

Your Harman Oakwood can be burned like a fireplace with the optional Cozy Screen. The Cozy Screen can be used with either the door in place or with the cast iron door removed from the stove. When using the Cozy Screen, the damper bypass must stay in the open position or smoke spillage will occur. The Cozy Screen has a smoke deflector on it that is recommended to be used in all applications and must be used on all rear vent models. Note: Depending on how well the draft is in your installation, the smoke deflector may not be needed on the top vent models.

The Cozy Screen can be used from the start of a fire or can be used with an existing one. When starting a fire with the Cozy Screen, smoke spillage may occur until it develops a draft strong enough to pull all smoke back into the flue.

Outside Air

The Oakwood is designed to accommodate the use of outside air introduced directly to the stove. The opening is located at the back of the stove. An outside air connector plate attaches over this opening, using (2) button head bolts (already on stove).

Check with your local building inspector to find out requirements determining if outside air is needed when installing the Oakwood in your area. Some signs to watch for that indicate a possible need for outside air: poor performance of other heaters or of the Oakwood, including smoke roll-out and odor; the disappearance of the same symptoms when a window is opened near the stove; and condensation on windows in the winter. Modern homes with tight windows and doors, vapor barriers, and particularly with exhaust systems are the most likely to require outside air.

An outside air duct less than 5' (1525 mm) long may be 3" [80mm] in diameter, and be made of masonry tile, 26 gauge (0.019) galvanized steel, or other approved noncombustible material; it should have a 1" (25 mm) clearance to combustibles. Systems longer than 5' (1525 mm), or containing more than two elbows, should have a 4" (100 mm) diameter duct to provide an adequate flow of combustion air. The air supply must originate outside the dwelling and be screened to keep out debris, birds or animals.

DO NOT INSTALL IN A SLEEPING ROOM

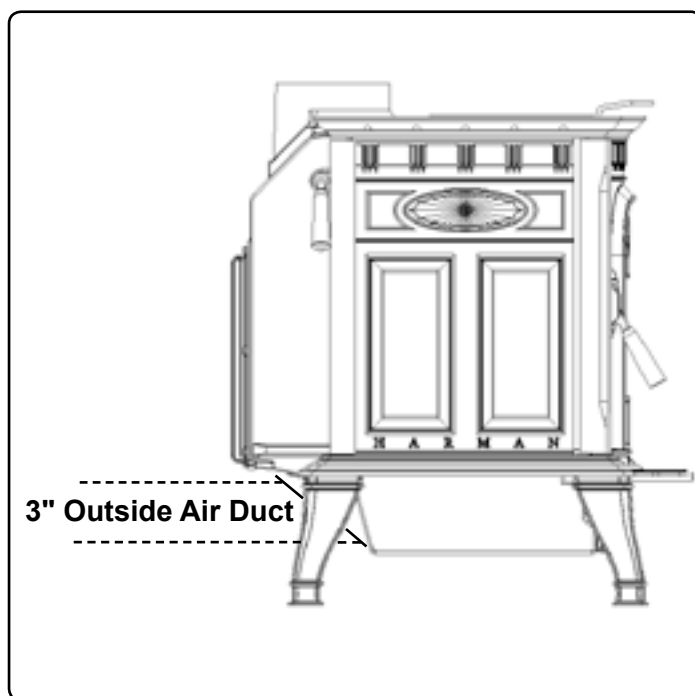

Retired units

1-90-02490-2 (Charcoal) (Ending Manufacturing Date: June 2011)
1-90-02490-3 (Goldenfire) (Ending Manufacturing Date: June 2011)
1-90-02490-4 (Metallic Blue) (Ending Manufacturing Date: Jan 2010)

1-90-02490-5 (Honey Glo) (Ending Manufacturing Date: June 2009)
1-90-02490-10 (Mojave Red) (Ending Manufacturing Date: Jan 2010)
1-90-02490-12 (Forest Green) (Ending Manufacturing Date: Jan 2010)

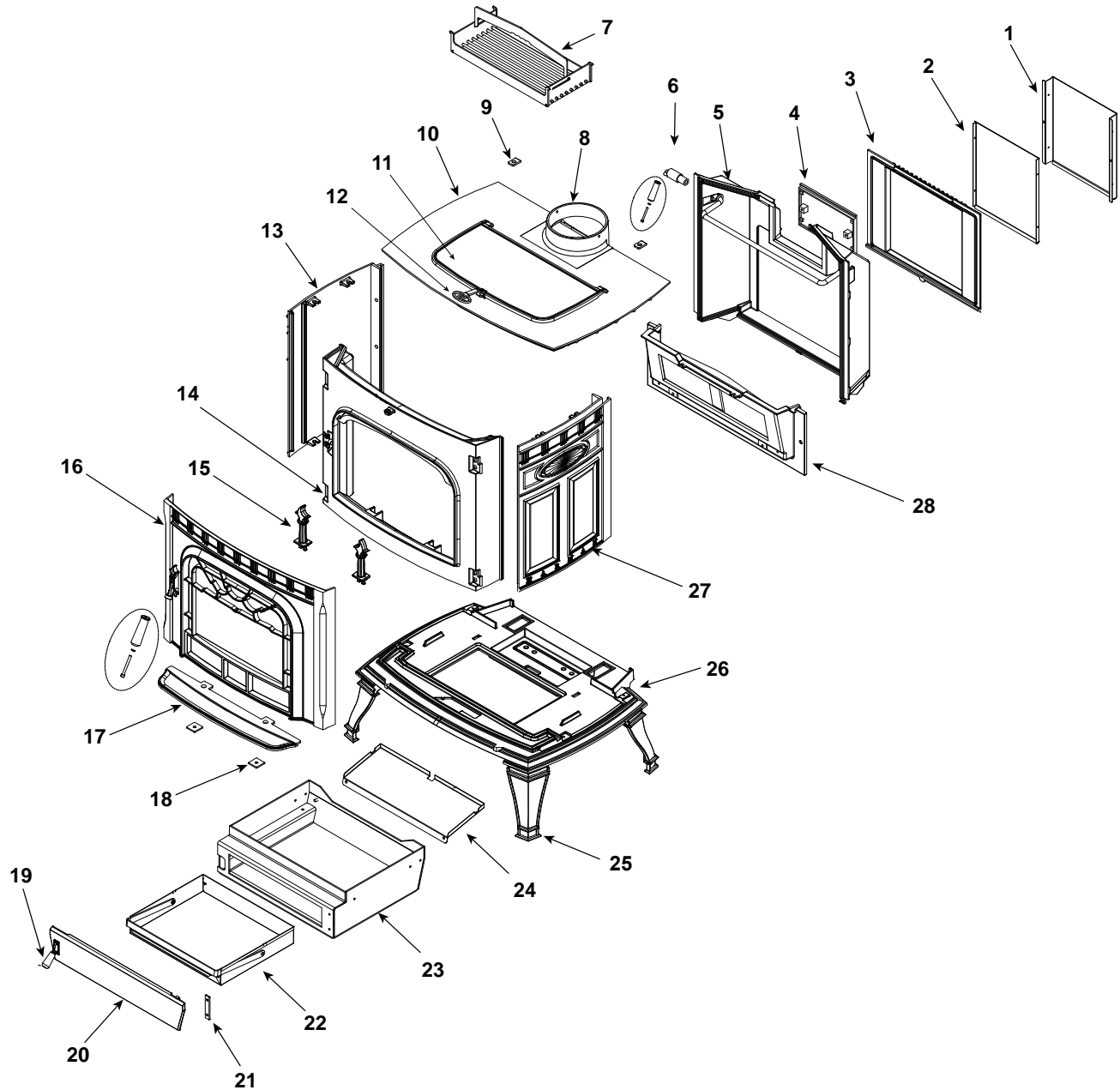

Part number list on following page.

IMPORTANT: THIS IS DATED INFORMATION. When requesting service or replacement parts for your appliance please provide model number and serial number. All parts listed in this manual may be ordered from an authorized dealer.



**Stocked
at Depot**

ITEM	DESCRIPTION	COMMENTS	PART NUMBER	
1	UL Label Outer Shield		2-00-249162S	
2	UL Label Inner Shield		2-00-249161S	
3	Rear Housing Cover Assembly w/Gasket		1-10-249116A	
	Gasket	10 Ft	1-00-11862	Y
4	Flue Collar Cover with Gasket		1-10-249109	
5	Rear Housing		4-00-249110S	
	Gasket, 3/8" RD LPSA	10 Ft	1-00-00999	Y
6	Damper Handle Painted		3-50-00500S	Y
7	Cook Grill Assembly	Optional	1-00-08121	
8	Flue Collar		4-00-249108D	
9	Top Hinge Plate	Qty 2 req	2-00-249147S	
10	Top		4-00-249105P	
	Gasket	30 Ft	1-00-00888	Y
11	Top Load Door		3-00-249115P	
	Gasket	5 Ft	1-00-37525	Y
12	Top Load Handle		2-00-249148	
	Top Handle Retainer		2-00-249190	
13	Left Side Panel		4-00-249103D	
14	Inner Front		4-00-249111S	
15	Andiron	Qty 2 req	3-00-249101P	Y
16	Front Load Door		4-00-249112P	Y
	Door Glass		3-40-21130	Y
	Gasket - Glass	15 Ft	1-00-2312	Y
	Gasket - Door	30 Ft	1-00-00888	Y
	Glass Clips & Hardware	Set of 4	1-00-249140	Y
	Hinge Plate		3-00-249136	

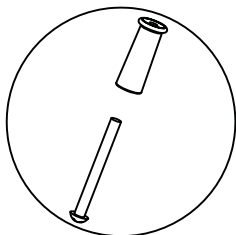

Handle Assembly

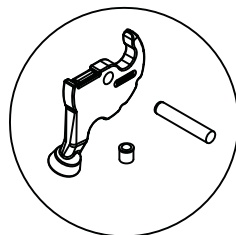

Handle & Plunger Kit

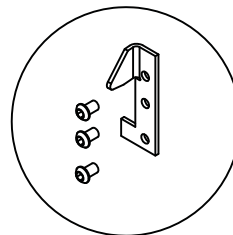

**Retainer Plate W/
Hardware**

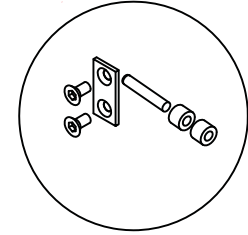

**Inner Front Plate
Latch Kit**

	Handle Assembly	2 Sets	1-00-00249	Y
	Handle and Plunger Kit		1-00-73765	Y
	Retainer Plate W/Hardware		1-00-249138	Y
	Inner Front Latch Kit		1-00-249143	Y

Additional service part numbers appear on following page.

IMPORTANT: THIS IS DATED INFORMATION. When requesting service or replacement parts for your appliance please provide model number and serial number. All parts listed in this manual may be ordered from an authorized dealer.



**Stocked
at Depot**

ITEM	DESCRIPTION	COMMENTS	PART NUMBER	
17	Ash Lip		3-00-249121P	
18	Ash Fender Bolt Plate	Qty 2 req	2-00-249169L	
19	Wood Knob	Pkg of 3	3-40-08746-3	
20	Ash Door		4-00-249113D	
	Ash Door Latch Hardware		1-00-24923	Y
	Ash Door Latch		3-00-249149	
	Ash Door Gasket	5 Ft	1-00-43375	Y
	Ash Door Hinge		2-00-249150	
21	Hinge Stiffener		2-00-249188L	
22	Ash Pan		1-10-249151	Y
23	Steel Ash Box Weldment		1-10-249144S	
24	Ca Shield		2-00-249157B	
25	Leg	Qty 4 req	4-00-249100P	Y
26	Bottom		4-00-249104D	
27	Right Side Panel		4-00-249102D	
28	Damper Frame Assembly w/Gasket		1-10-249106	Y
	Gasket	30 Ft	1-00-00888	Y
	Damper w/Adjuster		1-10-249107	
	Damper Linkage		1-10-249146	Y
	Damper Shaft Retainers and Hardware	1 Set	1-00-249145	Y
	Adjuster w/Hardware	Pre 00726440	1-00-249142	Y
		Post 008426440	1-00-250153	

#30 Air Slide assembly

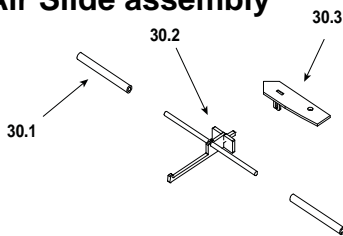

#31 Flue Shield Assembly

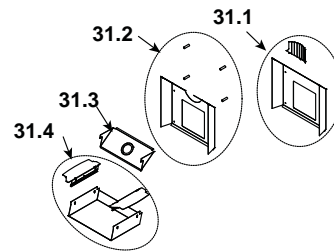

	Air Slide Assembly			
30.1	Air Adjuster Pipe	Qty 2 req	2-00-249158S	
30.2	Air Adjuster Weldment		1-10-249130S	
30.3	AirSlide Weldment		1-10-249131W	
31.1	Back Heat Shield Kit -Top Vent		1-00-02492	
31.2	Back Heat Shield Kit - Rear Vent		1-00-02493	
31.3	Outside Air Option		1-00-02494	
31.4	Bottom Heat Shield Kit		1-00-02491	

Additional service part numbers appear on following page.

IMPORTANT: THIS IS DATED INFORMATION. When requesting service or replacement parts for your appliance please provide model number and serial number. All parts listed in this manual may be ordered from an authorized dealer.



**Stocked
at Depot**

ITEM	DESCRIPTION	COMMENTS	PART NUMBER	
#32 Firebox Assembly				
32.1	Combustion Package		3-40-06999	Y
32.2	Inlet Brick Right		3-40-00104	Y
32.3	Logo Brick		3-40-00101	Y
32.4	Inlet Brick Left		3-40-00103	Y
32.5	Upper Brick Clip	Pkg of 2	1-00-249172	Y
32.6	Rear Brick Clip	Pkg of 2	1-00-249153	Y
32.7	Cast Left Inside Plate w/Gasket		1-10-249117A	Y
32.8	Grate		2-00-249122	Y
32.9	Cast Right Inside Plate w/Gasket		1-10-249118A	Y
32.10	Rear Brick Retainer	Pkg of 2	1-00-249135	
32.11	Shoe Brick		3-40-00100	Y
	Gasket, shoe Brick		3-44-06951	Y
32.12	Side Brick	Qty 2 req	3-40-00102	Y
	Brick Insulation	Qty 2 req	3-40-00250	
Hardware Packages				
	Bolt, 5/16-18 x 2" Zinc Plated Carriage	Pkg of 25	3-30-4001-25	Y
	Bushing 3/8 OD X 1/4" OAL	Pkg of 5	3-50-00058-5	Y
	Nut, 1/4"-20 Zinc Plated Finished Hex	Pkg of 100	3-30-8004-100	Y
	Screw, 5/16"-18 x 3/8" Alloy Steel Black Oxide Knurled Point SSS	Pkg of 25	3-30-2004-25	Y
	Screw, 1/4"-20 x 1" Alloy Steel Black Oxide Socket Head Cap	Pkg of 50	3-30-3004-50	Y
	Screw, 1/4"-20 x 3/8" Alloy Steel Black Oxide Button Head Cap	Pkg of 100	3-30-3014-100	Y
	Washer, 1/4" Zinc Plated USS Flat	Pkg of 100	3-30-0202-100	Y
	Washer, 5/16" Zinc Plated SAE Flat	Pkg of 50	3-30-0205-50	Y
	Washer-D 5/16	Pkg of 4	3-30-0400311-4	

**Hearth & Home Technologies Inc.
LIMITED LIFETIME WARRANTY**

Hearth & Home Technologies Inc., on behalf of its hearth brands ("HHT"), extends the following warranty for HHT gas, wood, pellet, coal and electric hearth appliances that are purchased from an HHT authorized dealer.

WARRANTY COVERAGE:

HHT warrants to the original owner of the HHT appliance at the site of installation, and to any transferee taking ownership of the appliance at the site of installation within two years following the date of original purchase, that the HHT appliance will be free from defects in materials and workmanship at the time of manufacture. After installation, if covered components manufactured by HHT are found to be defective in materials or workmanship during the applicable warranty period, HHT will, at its option, repair or replace the covered components. HHT, at its own discretion, may fully discharge all of its obligations under such warranties by replacing the product itself or refunding the verified purchase price of the product itself. The maximum amount recoverable under this warranty is limited to the purchase price of the product. This warranty is subject to conditions, exclusions and limitations as described below.

WARRANTY PERIOD:

Warranty coverage begins on the date of original purchase. In the case of new home construction, warranty coverage begins on the date of first occupancy of the dwelling or six months after the sale of the product by an independent, authorized HHT dealer/ distributor, whichever occurs earlier. The warranty shall commence no later than 24 months following the date of product shipment from HHT, regardless of the installation or occupancy date. The warranty period for parts and labor for covered components is produced in the following table.

The term "Limited Lifetime" in the table below is defined as: 20 years from the beginning date of warranty coverage for gas appliances, and 10 years from the beginning date of warranty coverage for wood, pellet, and coal appliances. These time periods reflect the minimum expected useful lives of the designated components under normal operating conditions.

Warranty Period		HHT Manufactured Appliances and Venting							Components Covered
Parts	Labor	Gas	Wood	Pellet	EPA Wood	Coal	Electric	Venting	
1 Year		X	X	X	X	X	X	X	All parts and material except as covered by Conditions, Exclusions, and Limitations listed
2 years				X	X	X			Igniters, electronic components, and glass
		X	X	X	X	X			Factory-installed blowers
				X					Molded refractory panels
3 years				X					Firepots and burnpots
5 years	1 year			X	X				Castings and baffles
7 years	3 years		X	X	X				Manifold tubes, HHT chimney and termination
10 years	1 year	X							Burners, logs and refractory
Limited Lifetime	3 years	X	X	X	X	X			Firebox and heat exchanger
90 Days		X	X	X	X	X	X	X	All replacement parts beyond warranty period

See conditions, exclusions, and limitations on next page.

WARRANTY CONDITIONS:

- This warranty only covers HHT appliances that are purchased through an HHT authorized dealer or distributor. A list of HHT authorized dealers is available on the HHT branded websites.
- This warranty is only valid while the HHT appliance remains at the site of original installation.
- Contact your installing dealer for warranty service. If the installing dealer is unable to provide necessary parts, contact the nearest HHT authorized dealer or supplier. Additional service fees may apply if you are seeking warranty service from a dealer other than the dealer from whom you originally purchased the product.
- Check with your dealer in advance for any costs to you when arranging a warranty call. Travel and shipping charges for parts are not covered by this warranty.

WARRANTY EXCLUSIONS:

This warranty does not cover the following:

- Changes in surface finishes as a result of normal use. As a heating appliance, some changes in color of interior and exterior surface finishes may occur. This is not a flaw and is not covered under warranty.
- Damage to printed, plated, or enameled surfaces caused by fingerprints, accidents, misuse, scratches, melted items, or other external sources and residues left on the plated surfaces from the use of abrasive cleaners or polishes.
- Repair or replacement of parts that are subject to normal wear and tear during the warranty period. These parts include: paint, wood, pellet and coal gaskets, firebricks, grates, flame guides, light bulbs, batteries and the discoloration of glass.
- Minor expansion, contraction, or movement of certain parts causing noise. These conditions are normal and complaints related to this noise are not covered by this warranty.
- Damages resulting from: (1) failure to install, operate, or maintain the appliance in accordance with the installation instructions, operating instructions, and listing agent identification label furnished with the appliance; (2) failure to install the appliance in accordance with local building codes; (3) shipping or improper handling; (4) improper operation, abuse, misuse, continued operation with damaged, corroded or failed components, accident, or improperly/incorrectly performed repairs; (5) environmental conditions, inadequate ventilation, negative pressure, or drafting caused by tightly sealed constructions, insufficient make-up air supply, or handling devices such as exhaust fans or forced air furnaces or other such causes; (6) use of fuels other than those specified in the operating instructions; (7) installation or use of components not supplied with the appliance or any other components not expressly authorized and approved by HHT; (8) modification of the appliance not expressly authorized and approved by HHT in writing; and/or (9) interruptions or fluctuations of electrical power supply to the appliance.
- Non-HHT venting components, hearth components or other accessories used in conjunction with the appliance.
- Any part of a pre-existing fireplace system in which an insert or a decorative gas appliance is installed.
- HHT's obligation under this warranty does not extend to the appliance's capability to heat the desired space. Information is provided to assist the consumer and the dealer in selecting the proper appliance for the application. Consideration must be given to appliance location and configuration, environmental conditions, insulation and air tightness of the structure.

This warranty is void if:

- The appliance has been over-fired or operated in atmospheres contaminated by chlorine, fluorine, or other damaging chemicals. Over-firing can be identified by, but not limited to, warped plates or tubes, rust colored cast iron, bubbling, cracking and discoloration of steel or enamel finishes.
- The appliance is subjected to prolonged periods of dampness or condensation.
- There is any damage to the appliance or other components due to water or weather damage which is the result of, but not limited to, improper chimney or venting installation.

LIMITATIONS OF LIABILITY:

- The owner's exclusive remedy and HHT's sole obligation under this warranty, under any other warranty, express or implied, or in contract, tort or otherwise, shall be limited to replacement, repair, or refund, as specified above. In no event will HHT be liable for any incidental or consequential damages caused by defects in the appliance. Some states do not allow exclusions or limitation of incidental or consequential damages, so these limitations may not apply to you. This warranty gives you specific rights; you may also have other rights, which vary from state to state. EXCEPT TO THE EXTENT PROVIDED BY LAW, HHT MAKES NO EXPRESS WARRANTIES OTHER THAN THE WARRANTY SPECIFIED HEREIN. THE DURATION OF ANY IMPLIED WARRANTY IS LIMITED TO DURATION OF THE EXPRESSED WARRANTY SPECIFIED ABOVE.

NOTES

At Harman, we build each product to a standard, not a price. This powerful heating appliance boasts uncompromising attention to detail and helps preserve our planet by using environmentally responsible fuels.



(Signature of Boxer)

Your premium quality hearth product designed and assembled by the experienced and skilled members at Harman in Halifax, PA, USA.

HARMAN[®]

BUILT TO A STANDARD, NOT A PRICE

Proudly Printed On 100% Recycled Paper

