

# Installation & Operating Manual

## The Accentra Pellet Stove

**HARMAN**<sup>TM</sup>  
HOME HEATING

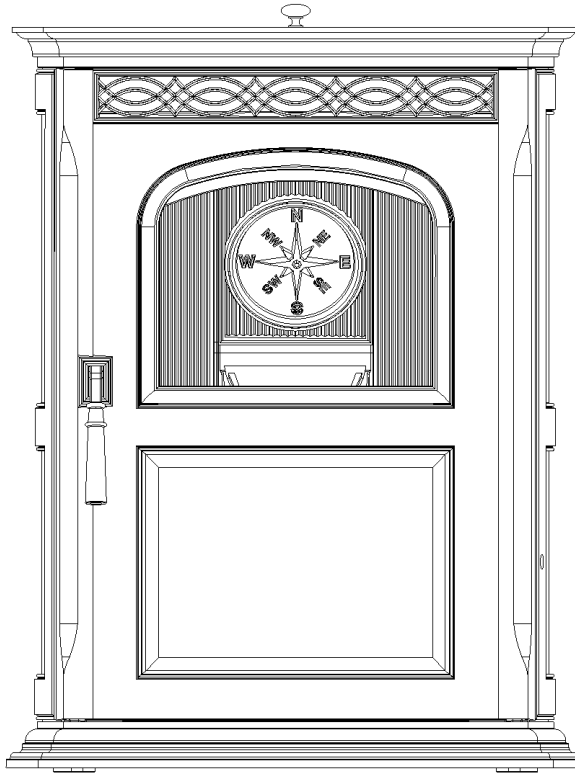

We suggest that our hearth products be installed and serviced by professionals who are certified in the U.S. by the National Fireplace Institute (NFI) as NFI Specialists.

*“Ce manuel est disponible en Français sur demande”*



### SAFETY NOTICE

PLEASE READ THIS ENTIRE MANUAL BEFORE YOU INSTALL AND USE YOUR NEW ROOM HEATER. FAILURE TO FOLLOW INSTRUCTIONS MAY RESULT IN PROPERTY DAMAGE, BODILY INJURY, OR EVEN DEATH.

FOR USE IN THE U.S. AND CANADA. SUITABLE FOR INSTALLATION IN MOBILE HOMES

IF THIS HARMAN ACCENTRA PELLET STOVE IS NOT PROPERLY INSTALLED, A HOUSE FIRE MAY RESULT. FOR YOUR SAFETY, FOLLOW INSTALLATION DIRECTIONS.

CONTACT LOCAL BUILDING OR FIRE OFFICIALS ABOUT RESTRICTIONS AND INSTALLATION INSPECTION REQUIREMENTS IN YOUR AREA.

CONTACT YOUR LOCAL AUTHORITY (SUCH AS MUNICIPAL BUILDING DEPARTMENT, FIRE DEPARTMENT, FIRE PREVENTION BUREAU, ETC.) TO DETERMINE THE NEED FOR A PERMIT.

CETTE GUIDE D'UTILISATION EST DISPONIBLE EN FRANCAIS. CHEZ VOTRE CONCESSIONNAIRE DE HARMAN HOME HEATING.

**SAVE THESE INSTRUCTIONS.**

Item # 3-90-08326

Tested & Listed By **UL** **ETL** **CS** **US**  
 Portland Oregon USA  
 OMI-Test Laboratories, Inc.  
 Report #/Rapport #135-S-10b-2

**Model: ACCENTRA-2**  
 Room Heater Pellet Fuel Burning

Also for use in Mobile Homes.  
 This pellet burning appliance has been tested and listed for use in Manufactured Homes in accordance with OAR 814-23-900 through 814-23-909

**MINIMUM CLEARANCES TO**

**COMBUSTIBLES**  
 Back Wall to Appliance 2.25"  
 Side Wall to Appliance 12"  
 Corner Installation  
 Walls to Appliance 6.25"  
 Use a non-combustible floor protector extending under unit and to the sides, front and back of unit as shown in Floor Protection Diagram. Measure from distance from the surface of the glass door.  
 Recommended: Non-combustible floor protection extending beneath the fluepipe when installed with horizontal venting.

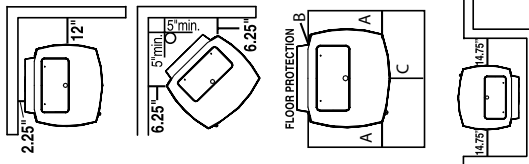

**FLOOR PROTECTION\***

USA Canada  
 Sides (A) 6" 8" / 700mm  
 Back (B) 0" 0" / 0mm  
 Front (C) 6" 18" / 46cm  
 \*Measured From Glass Opening  
**Alcove Installation**  
 Min. Alcove Height 60"  
 Min. Alcove Side Wall 14.75"  
 Max. Alcove Depth 24"

**U.S. ENVIRONMENTAL PROTECTION AGENCY**

This model is exempt from EPA certification under 40 CFR 60.531 by definition [Wood Heater (A) "Air-to-fuel Ratio"]

Tested & Listed By **UL** **ETL** **CS** **US**  
 Portland Oregon USA  
 OMI-Test Laboratories, Inc.  
 Report #/Rapport #135-S-10b-2

Tested to ASTM E 1509-04, ULC S627-00, and ULC-C1482-M1990  
 Tested by Emitech, Apave & BFP Electronique  
 EN60335-1, EN55014-1, EN 61000-3-2, EN 14785:2005  
 Test date: February 2004  
 Room Heater Pellet Fuel Burning type (UM) 84-HUD  
**\*PREVENT HOUSE FIRES\*** Install and use only in accordance with manufacturer's installation and operation instructions. Contact local building or fire officials about restrictions and inspection in your area.  
**WARNING: FOR MANUFACTURED HOMES:** Do not install appliance in a sleeping room. An outside combustion air inlet must be provided. The structural integrity of the manufactured home floor, ceiling and walls must be maintained.  
 Refer to manufacturer's instructions and local codes for precautions required for passing chimney through a combustible wall or ceiling. Inspect and clean exhaust venting system frequently in accordance with manufacturer's instructions.  
 Use a 3" or 4" diameter type "L" or "PL" venting system.  
 Do not connect this unit to a chimney flue servicing another appliance.  
**FOR USE WITH PELLETTIZED WOOD FUEL OR A-SHELLED CORN/PELLET MIXTURE ONLY.**  
 Input Rating Max: 5.7 lb. fuel/hr.  
 Electrical Rating: 240 VAC, 50 Hz, Start 2.0 AMPS, Run 1.1 AMPS  
 U.S. Electrical Rating: 115 VAC, 60 Hz, Start 4.1 AMPS, Run 2.2 AMPS  
 Emission of CO in Combustion:  
 Nominal Heat Output: < 0.02%, Reduced Heat Output: < 0.04%  
 Flue Gas Temperature: 224°C  
 Thermal Output: 10.5Kw  
 Energy Efficiency: Nominal: 84%; Reduced: 73%

Fuel Type: Wood Pellets, 5mm diameter, 20mm long  
 Route power cord away from unit.  
**DANGER:** Risk of electrical shock. Disconnect power supply before servicing.  
 Replace glass only with 5mm ceramic available from your dealer.  
 For further instruction refer to owner's manual.  
 Keep viewing and ash removal doors tightly closed during operation.  
 Do not remove this label/Ne pas enlever cette étiquette. Made in USA/Fabrique aux É.-U.

Serial No. **008**  
 No. de série

**Modèle : ACCENTRA-2**  
 Appareil de chauffage à granulés de bois



Tests réalisés par OMI TEST LABORATORIES, Inc.  
 Rapport N°135-S-10b-2  
 Essais selon les normes 1509-04 de l'ASTM, ULC S627-00, et ULC-C1482-M1990  
 Appareil de chauffage à granulés (UM) 84-HUD  
**NORMES EUROPEENNES:**  
 NF EN 14785 CETIAT - Dec. 2006  
 AEMC MESURES EN50366 - Dec. 2006  
 EMITECH, APAVE & BFP Electronique - Fév. 2004  
 EN55014-1, EN 55014-2, EN 61000-3-2, EN 61000-3-3  
**PREVENTION DES INCENDIES**  
 Respecter soigneusement les instructions du constructeur pour l'installation et les consignes de fonctionnement. Respecter les règles de sécurité en vigueur dans votre région.  
**Il est impératif de prévoir une prise d'air extérieur. L'intégrité structurelle du plancher, du plafond et des murs doit être strictement préservée.**  
 Se reporter aux instructions du fabricant et aux réglementations spécifiques locales concernant les précautions requises lors de la traversée d'un mur ou d'un plafond. Contrôler et nettoyer fréquemment tout le système d'évacuation des fumées conformément aux recommandations du constructeur.  
 Utiliser des conduits « Spécial granulés » de diamètre 80 mm ou 100 mm.  
 Ne pas raccorder ce poêle à un conduit de cheminée déjà utilisé.  
**FUNCTIONNE EXCLUSIVEMENT AVEC DES GRANULES DE BOIS.**  
**SE CONFORMER AUX INSTRUCTIONS D'UTILISATION**  
 Consommation maximale: 2,16 kg/h  
 Caractéristiques électriques: 240 V.C, 50 Hz, Intensité au démarrage 2 A, Intensité fonctionnement normal 1,1 A  
 Tenir le cordon d'alimentation à l'écart du poêle.

**COMBUSTIBLES**  
 Entre mur arrière et appareil 6 cm  
 Entre paroi latérale et appareil 31 cm  
**Installation en angle**  
 Entre murs et appareil 16 cm  
**PROTECTION DU PLANCHER**  
 USA Canada  
 Côtés (A) 15 cm 8" / 700mm  
 Arrière (B) 0 cm 0" / 0mm  
 Parois latérales de l'alcôve 38 cm  
 Avant (C) 15 cm 18" / 46cm  
 Profondeur maximale de l'alcôve 60 cm  
 Utiliser une protection de sol non combustible sous l'appareil qui s'étend sur les côtés, l'avant et l'arrière du poêle (voir schéma). Pour la distance à l'avant, mesurer à partir de la surface de la porte en verre.  
 Il est recommandé que la protection s'étende jusque sous le conduit en cas d'installation d'un conduit horizontal ou sous le té en cas de conduit vertical.

**DANGER** - Risque d'électrocution. Débrancher l'appareil avant toute intervention.  
 Ne remplacer la vitre qu'avec une vitre céramique de 5 mm de même qualité disponible auprès de votre revendeur.  
 Pour une information plus complète, se reporter à la notice d'utilisation.  
 Tenir la porte frontale et le couvercle de trémie hermétiquement clos durant le fonctionnement de l'appareil.  
**Puissance calorifique émise:** Nominale: 10.5 Kw Réduite: 1.8 Kw  
**Concentration CO (à 13 % O2)**  
 à puissance nominale: < 0.02 % à puissance réduite: < 0.04 %  
**Rendement** à puissance nominale: 84%; à puissance réduite: 73 %

**DISTANCES DE SECURITE PAR RAPPORT AUX MATERIAUX COMBUSTIBLES**  
 Entre mur arrière et appareil 6 cm  
 Entre paroi latérale et appareil 31 cm  
**Installation en angle**  
 Entre murs et appareil 16 cm  
**PROTECTION DU PLANCHER**  
 USA Canada  
 Côtés (A) 15 cm 8" / 700mm  
 Arrière (B) 0 cm 0" / 0mm  
 Parois latérales de l'alcôve 38 cm  
 Avant (C) 15 cm 18" / 46cm  
 Profondeur maximale de l'alcôve 60 cm  
 Utiliser une protection de sol non combustible sous l'appareil qui s'étend sur les côtés, l'avant et l'arrière du poêle (voir schéma). Pour la distance à l'avant, mesurer à partir de la surface de la porte en verre.  
 Il est recommandé que la protection s'étende jusque sous le conduit en cas d'installation d'un conduit horizontal ou sous le té en cas de conduit vertical.

Ce modèle est dispensé par EPA certification d'après 40 CFR 60.531 par définition [Appareil à bois(A) Ratio air/combustion]



Manufactured by/Amérique par: Harman Stove Company  
 352 Mountain House Road, Halifax, PA 17032 (E-U)

**AGENCE AMERICAINE POUR LA PROTECTION DE L'ENVIRONNEMENT**  
 Ce modèle est dispensé par EPA certification d'après 40 CFR 60.531 par définition [Appareil à bois(A) Ratio air/combustion]

Date of Manufacture/Date de fabrication :  
 2010 2011 2012 JAN FEB MAR APR MAY JUN JUL AUG SEPT OCT NOV DEC

This heating appliance does not just have automatic ignition, it has total automatic temperature control. The Accentra has an input heat range from 0 to 40,000 BTU's. This patented feed system has a maximum feed rate of 5 lbs. per hour and a minimum (maintenance) feed rate of .75 lbs. per hour and then "off" if necessary. The hopper holds approximately 50 pounds of fuel. The unit has an easy to clean combustion system with an ash pan that holds ash from 1 ton of burned premium pellets.

The control is designed for easy and efficient operation. It has 2 automatic modes of operation and 2 manual modes of operation.

The Accentra uses a small room sensor rather than a wall thermostat for more accurate temperature control. This unit is equipped with several different safety devices which will be explained later in this manual. With its specially designed burn pot and the "Advance Igniter" Automatic Ignition System, the unit can burn a large variety of pelletized fuels with varying ash content. The accordion style cast iron heat exchanger system allows maximum surface area for the most efficient heat transfer in a smaller firebox.

Please copy your serial number from the label on your stove to the box below.

**SERIAL NUMBER**

Tested & Listed By **O-T-L** US  
 CPTI  
 OMNI-Test Laboratories, Inc.  
 Report # Report #135-S-10b-2

Test to Tests ASTM E 1509-04, ULC S627-00, and ULC-C1482-M1990  
 Tested by Engh, Apwa & BFP Electronics  
 EN50391, EN50391-1, EN 61000-3-2, EN 61000-3-005  
 Test date: February 2004  
 Room Heater Pellet Fuel Burning Type: 100%

**\*PREVENT HOUSE FIRES** Use only in accordance with the installation and operation instructions. Contact local authorities for installation and operation instructions in your area.

**WARNING FOR MANUFACTURED HOMES:** Do not install this stove in a sleeping room. An outside combustion air inlet must be provided. The structural integrity of the manufactured home floor, ceiling and walls must be maintained.

Refer to manufacturer's instructions and local codes for precautions required for passing chimney through a combustible wall or ceiling. Inspect and clean exhaust venting system frequently in accordance with manufacturer's instructions.

Use a 1" or 1 1/2" diameter type "L" or "PL" venting system. Do not connect this unit to a chimney flue serving another appliance.

**FOR USE WITH PELLETED WOOD FUEL ONLY - UN-SHIELDED CORN PELLETS MIXTURE ONLY**

Input Rating: Max: 57.8 lbs/hr  
 Electrical Rating: 240 VAC, 50 Hz, Start 2.0 AMPS, Run 1.1 AMPS  
 U.S. Electrical Rating: 115 VAC, 60 Hz, Start 4.1 AMPS, Run 2.2 AMPS  
 Emission of CO: 0.10%  
 Nominal Heat Output: <0.2% Reduced Heat Output: <0.4%  
 Flue Gas Temperature: 224°  
 Thermal Output: 10,5kW  
 Energy Efficiency: Normal 84%, Reduced 73%  
 Fuel Type: Wood Pellets, 5mm diameter, 20mm long  
 Shelled Corn when mixed with Pellets

Route power cord away from unit.  
**DANGER:** Risk of electrical shock. Disconnect power supply before servicing. Replace glass only with 5mm ceramic available from your dealer. For further instruction refer to owner's manual.  
 Keep viewing and ash removal doors tightly closed during operation.

Do not remove this label! Ne pas enlever cette étiquette. Made in USA/Fabrique aux E.-U.

**Model: ACCENTRA-2**  
 Room Heater Pellet Fuel Burning  
 Also for use in Mobile Homes  
 This pellet burning appliance has been tested and listed for use in Manufactured Homes in accordance with OAR 814-23-900 through 814-23-909

**MINIMUM CLEARANCES TO COMBUSTIBLES**  
 Back Wall to Appliance: 12"  
 Side to Appliance: 6.25"  
 Use a non-combustible floor protector extending under unit and to the sides, front and back of unit as shown in Floor Protection Diagram. Measure front distance from the surface of the floor door.  
 Recommendation: Non-combustible floor protection extending beneath the fireplace when installed with horizontal venting.

**FLOOR PROTECTION\***  
 USA Canada  
 Sides (A) 6" 8"20cm  
 Back (B) 6" 8"6cm  
 Front (C) 6" 8"16cm  
 \*Minimum of 18mm Glass Opening

**Alcove Installation**  
 Min. Alcove Height 60"  
 Min. Alcove Side Wall 14.5"  
 Max. Alcove Depth 24"

**U.S. ENVIRONMENTAL PROTECTION AGENCY**  
 This model is exempt from EPA certification under 40 CFR 60.521 by definition (Wood Heater (A) "A" Approval Rating).

Modèle: ACCENTRA-2  
 Appareil de chauffage à granulés de bois

Serial No. / N° de série: **008**

Test réalisés par OMNI TEST LABORATORIES, Inc.  
 Rapport N°135-S-10b-2  
 Essai selon les normes 1509-04 de ASTM, ULC S627-00, et ULC-C1482-M1990  
 Appareil de chauffage à granulés (UM) 84-41UD

**NORMES EUROPEENNES:**  
 EN 50391, EN 50391-1, EN 61000-3-2, EN 61000-3-005  
 AEMC MESURES EN50396 - Dec. 2006  
 EMC/CEM, APRVE & BFP Electronics - Feb. 2004  
 EN50514-1, EN 55014-2, EN 61000-3-2, EN 61000-3-3

**PREVENTION DES INCENDIES**  
 Respecter soigneusement les instructions du constructeur pour l'installation et les consignes de fonctionnement. Respecter les règles de sécurité en matière de venting horizontal.

**AVERTISSEMENT POUR MOBILES HOMES:** Ne pas installer dans une chambre. Il est impératif de prévoir une prise d'air extérieure. L'intégrité structurelle du bâtiment, du plafond et des murs doit être soigneusement préservée. Se reporter aux instructions du fabricant et aux réglementations spécifiques. Inspectez soigneusement les précautions requises lors de la traversée d'un mur ou d'un plafond. Contrôlez et nettoyez fréquemment toute le système d'évacuation des fumées conformément aux recommandations du constructeur.

Utiliser des conduits de type "L" ou "PL" de diamètre 80 mm ou 100 mm. Ne pas raccorder ce poêle à un conduit de cheminée existant.

**FONCTIONNE EXCLUSIVEMENT AVEC DES GRANULES DE BOIS.**  
**SE CONFORMER AUX INSTRUCTIONS D'UTILISATION**  
 Consommation maximale: 2,16 kg/h  
 Caractéristiques électriques: 240 VAC, 50 Hz, Intensité au démarrage: 2,1 A  
 Intensité fonctionnement normal: 1,1 A  
 Tenir le conduit d'évacuation à l'écart du poêle.

**AGENCE AMERICAINNE POUR LA PROTECTION DE L'ENVIRONNEMENT**  
 Ce modèle est dispensé par EPA certification d'après 40 CFR 60.521 par définition (Appareil à bois/A) (Ratio air/combustion)

Date de Manufacture/Date de fabrication:  
 2010 2011 2012 JAN FEB MAR APR MAY JUN JUL AUG SEPT OCT NOV DEC

**SAFETY NOTICE: IF THIS HARMAN ACCENTRA PELLET STOVE IS NOT PROPERLY INSTALLED. A HOUSE FIRE MAY RESULT. FOR YOUR SAFETY, FOLLOW THE INSTALLATION DIRECTIONS. CONTACT LOCAL BUILDING OR FIRE OFFICIALS ABOUT RESTRICTIONS AND INSTALLATION INSPECTION REQUIREMENTS IN YOUR AREA.**



**Safety testing by Omni-Test Laboratories  
 ASTM-E1509-04 • ULC-S627-00 &  
 ULC/ORD-C1482-M1990 • Oregon-814-23-900  
 per 40CFR-60.530 sup. part AAA  
 per EPA method 28A and 5G  
 This appliance is also approved for  
 installation into a shop.**

**Harman Home Heating**  
 352 Mountain House Road  
 Halifax, PA 17032  
 www.harmanstoves.com

## Table of Contents

<b>ESP Control</b>	<b>4</b>
<b>Automatic Operation</b>	<b>5</b>
<b>Manual Operation</b>	<b>7</b>
<b>Assembly &amp; Installation</b>	<b>9</b>
<b>Venting</b>	<b>14</b>
<b>Maintenance</b>	<b>21</b>
<b>Trouble-Shooting</b>	<b>26</b>
<b>Specifications</b>	<b>27</b>
<b>Wiring Diagram</b>	<b>28</b>
<b>Corn Instructions</b>	<b>29</b>
<b>Warranty</b>	<b>30</b>
<b>Service Parts</b>	<b>32</b>

# ESP Control

## Mode Selector

Allows you to choose between Room Temp Mode, Stove Temp Mode, or OFF. Also allows you to vary the distribution blower speed by turning the knob to the high or low side of each mode.

Distribution Blower speed adjustment range.

L = low  
H = high  
Variable speed anywhere between L and H; although as the stove temp. goes up, so does the L and H scale.

## Igniter switch

Set to appropriate Start-Up mode.

## Test

Runs all motors at full speed for one minute to check operation. After two minutes the stove will go to minimum burn and the blowers will alternate from high to low every minute to remind you that you are still in "Test Mode".

## Feed adjuster

Sets the maximum feed rate

## Dealer Diagnostic Port

For dealer maintenance only. Requires special DDM monitor supplied to Harman Dealers exclusively.

## Temp dial

Allows you to adjust the room temperature in Room Temp Mode using the outer scale marked in degrees Fahrenheit. It also allows you to adjust the stove temperature while in Stove Temp Mode using the inner scale marked from 1 to 7.

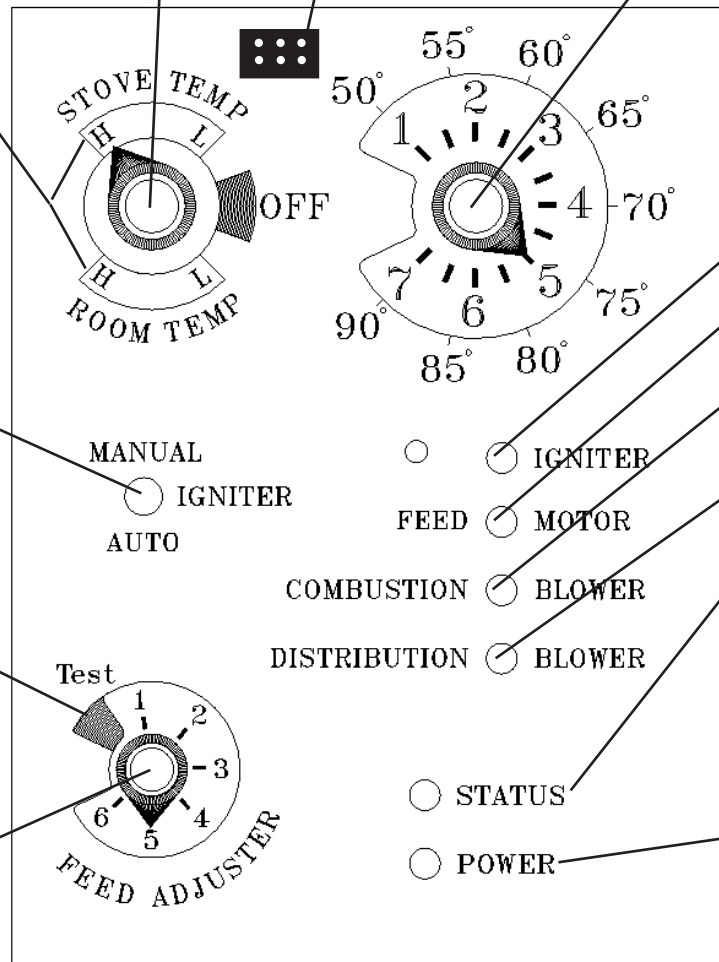

Indicates igniter is on.

Indicates power to the feed motor.

Indicates power to combustion blower

Indicates power to distribution blower.

## Status Light

Will be lit in either stove or room temp mode when pointer is not within off position band except after normal shut down. Blinks to indicate errors listed below.

## Power Light

Indicates power to the control.

## Status light error messages:

**3 Blinks:** Indicates that the ESP (Exhaust Sensing Probe) has gone out of range too many times. If the unit seems to be operating correctly, perform a manual reset\*.

**4 Blinks:** Can occur only in Room Temp Mode and indicates Room Sensing Probe failed or not installed. If a Room Sensing Probe is then installed, the status light will automatically reset.

NOTE: Unit will not start in "AUTO" with this status error.

**5 Blinks (In Igniter Auto. Mode Only):** Indicates that the unit has failed to light within the 36 minute start cycle. To reset - Turn Mode Selector to "OFF", then turn to either mode again.)

**6 Blinks :** Indicates that the control has calculated poor or incomplete combustion occurring for more than 50 minutes.

A six blink status may be set if the stove is allowed to run out of pellets. To reset, turn mode selector to "OFF" then back on to the desired mode. If the unit was not out of pellets, see Troubleshooting section, Page 26, for more details.

\* **Manual reset-** disconnect power cord for a few seconds and reconnect. If error still occurs call your Dealer.



The Accentra pellet stove is more than just automatic ignition, it is also automatic temperature control. The automatic system will allow the fire size to be adjusted to match the heating needs and even put the fire out if necessary. If heat is needed after the fire is out, the Accentra will automatically re-ignite and adjust the fire size to match the heating need. The totally automatic room sensor mode is recommended because of its efficiency. The unit can be switched between "AUTO" and "MANUAL" at any time during operation.

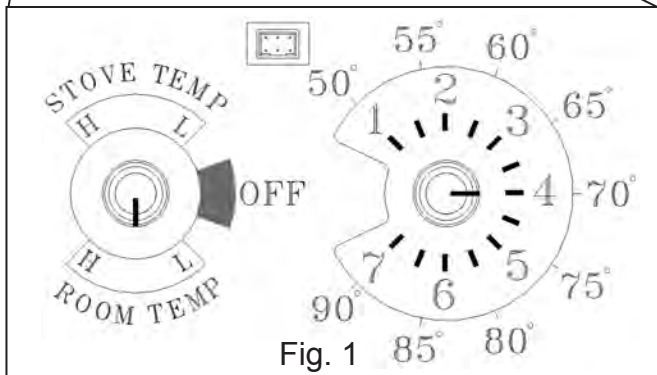
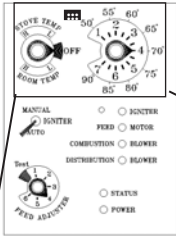

Fig. 1

**Room Temperature Mode:** This setting will produce a room temperature of 70 degrees with the distribution blower at medium speed.

## Igniter switch to "AUTO" **Room Temperature Mode**

In "Room Temp Mode" heat output is controlled automatically by the Room Sensing Probe. When the Room Sensing Probe calls for heat, the stove will increase output. When the Room Sensing Probe is getting close to the set temperature, the stove will begin to level off output and keep the fire burning at just the right temperature to maintain that setting.

High output is determined by the feed rate setting. This setting, generally on #4, can be increased if higher burn rates are necessary (Fig. 3). The unit's maximum burn rate should not create less than 1" of ash on the burn pot front edge (See Fig.4). Overfeeding is not a safety concern, but fuel may be wasted if unburned pellets fall into the ash pan.

In "Room Temp Mode" a constant fuel consumption rate is sacrificed for exact room temperature. Therefore, as it gets colder more pellets will be burned automatically.

The distribution blower speed will vary according to the position of the mode selector pointer, and fire size.

## Igniter switch to "AUTO" **Stove Temperature Mode**

This allows for automatic ignition upon start-up only. The unit can then be set at any desired setting. The heat output and fuel consumption will remain constant regardless of room temperature (See Fig 2). The unit's maximum feed rate should not create less than 1" of ash on the burn pot front edge (See Fig 4).

The unit's low burn or maintenance setting is as low as it will go. It will not go out unless it runs out of fuel or is turned to "off".

## Shut-Down Procedure

To kill the fire or stop burning the stove, turn the Mode Selector to "OFF". This will cause the fire to diminish and burn out. When the fire burns out and the stove cools down everything will stop.

If you pull the plug to shut down the stove, all motors will stop. This may cause incomplete combustion and smoke in the firebox. If the load door is opened the smoke may escape.

The best way to shut down the stove is simply let it run out of pellets, then the stove will shut down automatically.

## Stove Temperature Mode

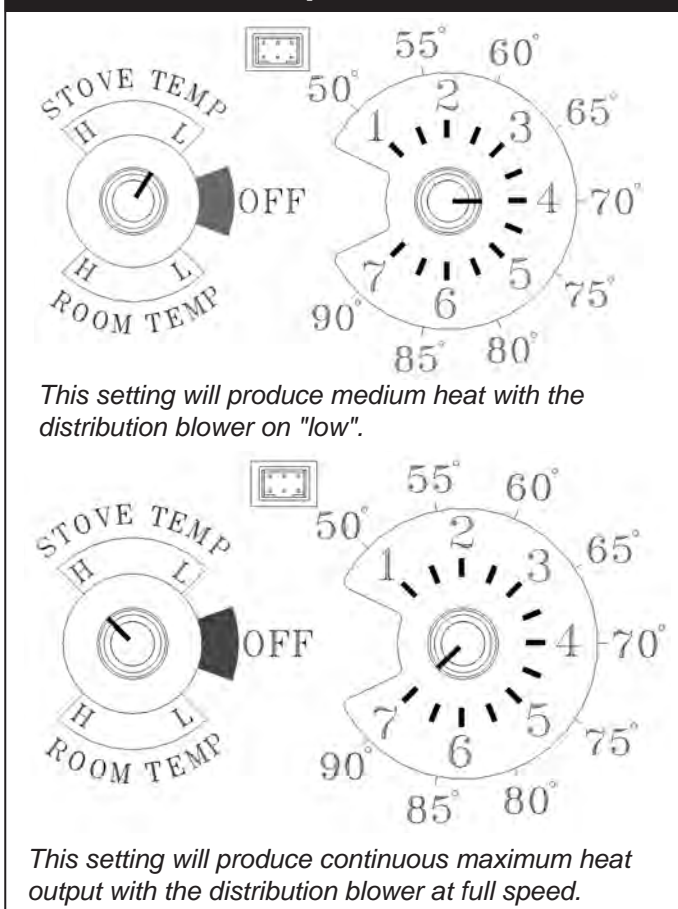

This setting will produce medium heat with the distribution blower on "low".

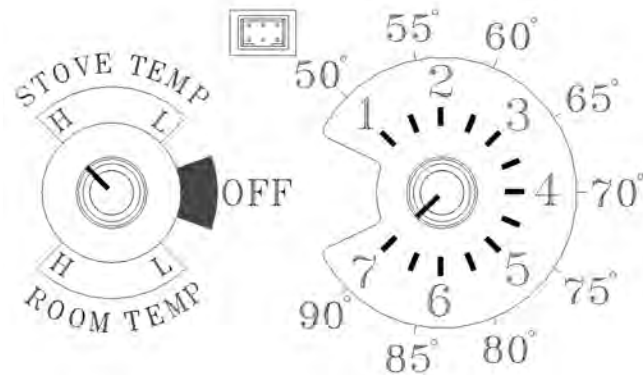

This setting will produce continuous maximum heat output with the distribution blower at full speed.

Fig. 2

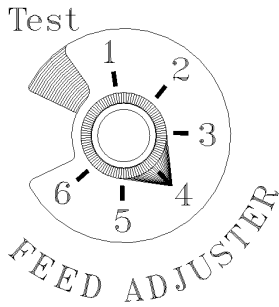

Fig. 3

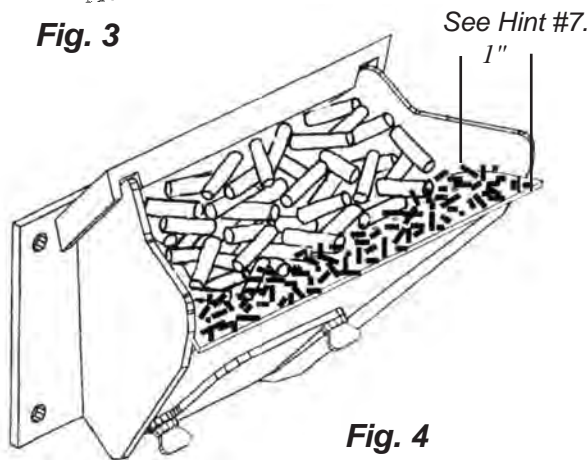

Fig. 4

### Helpful Hints

1. Fines are small pieces of broken pellets (sawdust). Fines do not flow easily and often build up on the hopper funnel bottom angles. These fines can be pushed into the feeder opening and then fill the hopper with pellets. As the system works, they will be burned.
2. The "TEST" cycle will operate the feeder motor for exactly one minute. Turning to "TEST" again and again may feed too much fuel into the burn pot causing excessive smoke on start-up.
3. The firebox low pressure switch will not allow the auger motor or the igniter element to operate if the view door is open.
4. Adjust Feed Rate. If this is your first fire or you are trying different pellets, set the feed adjuster to #4, Fig. 3. This is a conservative number and will probably need to be increased. After you know a feed rate setting that works well, use that setting. Remember, if your feed rate is too high you may waste fuel.
5. This is usually a weekly maintenance procedure. Cleaning the burn pot with the scraper with a small amount of new fuel in the bottom is not a problem. First, scrape the ashes on the front of the burn pot into the ash pan. Then scrape the holed surface downward into the burn pot. When the stove is ignited these scrapings will be pushed out by the feeder.
6. The ash pan can hold the ashes from approximately 1 ton of premium fuel. This means the ashes will only need to be emptied a few times a year.
7. Setting the feed adjuster # for maximum burn: With the unit burning in "AUTO", turn to "Stove Mode" and put the fan on "H". Set the Temperature Dial to #7. Allow the unit to burn for about 30 minutes and check ash on front of burn pot. Fig. 4. If the ash line is larger than 1", turn the feed adjuster from #4 to #5. Allow another 30 minutes of burn time and check again. If, at #6 setting, a 1" or less ash bed is not obtainable, it is not a problem. The 1" ash bed is only a maximum burn rate and at most normal settings the ash bed will be larger.

## Starting First Fire

### Igniter Switch to "AUTO" (down position)

Make sure the unit is plugged into a 120 VAC, 60 HZ electrical source. The power light should be the only light lit.

**IMPORTANT:** To avoid unwanted smoke, Be sure there is no fuel or other combustibles in the ash pan prior to lighting.

Keep all doors closed during operation. Maintain all seals and gaskets in good condition.

1. Turn Mode Selector to "OFF".
2. Fill hopper with pellets.<sup>1</sup>
3. Clean burn pot with scraper, if necessary.<sup>5</sup>
4. If starting after an empty hopper, turn Feed Adjuster to "TEST" (for one 60 second cycle).<sup>2</sup> This will feed pellets into the auger tube and also allow you to check the motors for operation. **NOTE: The auger motor will not operate with the view door or ash pan door open.**<sup>3</sup>
5. Turn Feed Adjuster to #4.<sup>4</sup>
6. Flip the Igniter Switch down into the "AUTO" position.
7. Turn the Temperature Dial to the desired room temperature.
8. Turn the Mode Selector to Room Temperature or Stove Temperature.
9. Fill the hopper with pellets and remove ashes as required.<sup>6</sup>

## Warning

**NEVER USE GASOLINE, GASOLINE-TYPE LANTERN FUEL, KEROSENE, CHARCOAL LIGHTER FLUID, OR SIMILAR LIQUIDS TO START OR 'FRESHEN UP' A FIRE IN THIS HEATER. KEEP ALL SUCH LIQUIDS WELL AWAY FROM THE HEATER WHILE IN USE.**

The Accentra Pellet Stove is capable of manual operation. This allows the operator to manually control operation and fuel consumption. Manual operation can also be helpful during an emergency (i.e. igniter failure, or when using certain generators.) The unit can be switched between "AUTO" and "MANUAL" at any time during operation.

**NOTE: When starting the unit in the "AUTO" mode, switching to "MANUAL" can be done at any time. Once an ignition cycle is started, it will continue, regardless of mode. There is no need to wait for the ignition cycle to complete.**

### Igniter Switch to "MANUAL" Room Temperature Mode

The fire will have to be lit with starting gel and a match, or started automatically, see "Automatic Operation". Turn to "Manual" position when the fire is established.

The difference between "AUTO" Room Temperature Mode and "Manual" Room Temperature Mode is that the fire will not go out as the room temperature goes above the control board setting. The unit can only go to low burn and will remain there until it runs out of fuel or until more heat is needed and the feed rate increases. Feed rate adjustments and dial settings are the same as "AUTO" settings.

### Igniter Switch to "MANUAL" Stove Temperature Mode

The advantage of this mode is to allow the operator to have a large viewing fire without blowing extra heat into the room.

During operation, with the temperature dial set at #5 or less, the distribution fan will not operate. A #5 on the temperature dial and a #5 on the feed adjuster is approximately 80% output. The distribution blower will not operate below this point. Therefore, there can be a higher feed rate ( a larger viewing fire) without an excess of hot air blowing into the room.

An example of when to use the Manual Stove Temperature Mode is if you want to watch a large fire and the room is already up to temperature. The Stove Temperature Mode allows you to have a larger fire and a lower sound level, without the distribution blower.

**NOTE: During the use of this mode, if you keep increasing the temperature dial setting to increase the fire size, the distribution blower will automatically come on when the ESP Temperature reaches 350° F, or 81% output.**

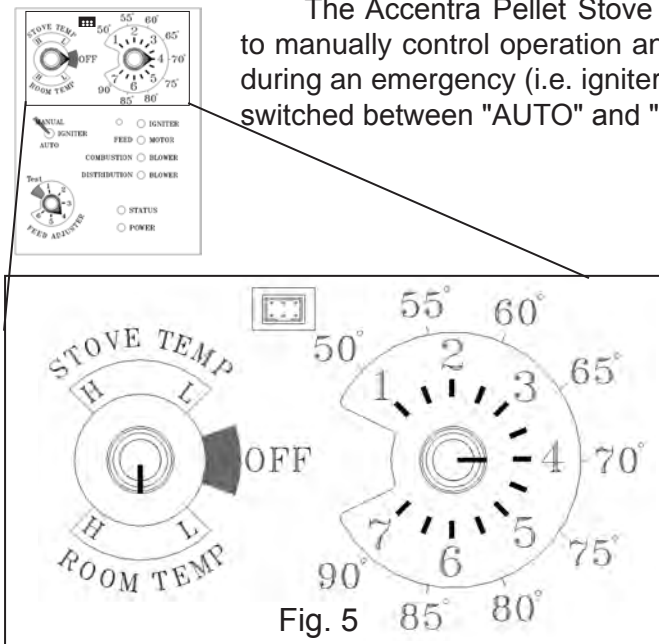

Fig. 5

**Room Temperature Mode:** This setting will produce a room temperature of 70 degrees with the distribution blower at medium speed.

## Manual Stove Temperature Mode

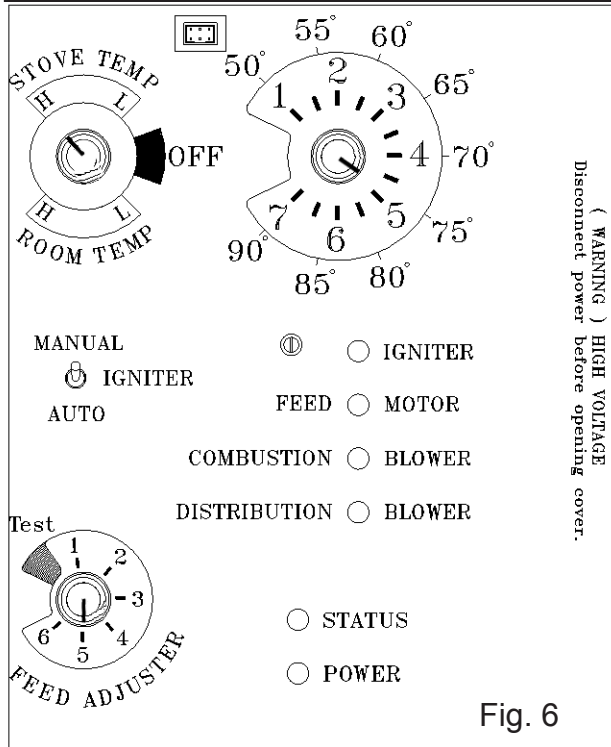

Fig. 6

This setting will produce a large viewing fire without a distribution blower operating.

### Shut-Down Procedure

Turn the Mode Selector to "OFF". This will allow the fire to diminish and burn out. When the fire burns out and the ESP cools, everything will stop. Never pull the plug to shut down the stove. This will cause incomplete combustion and smoke in the firebox. If the load door is opened the smoke may escape.

The best way to shut down the stove is simply let it run out of pellets, then the stove will shut down automatically.



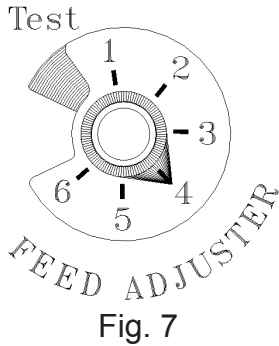

Fig. 7

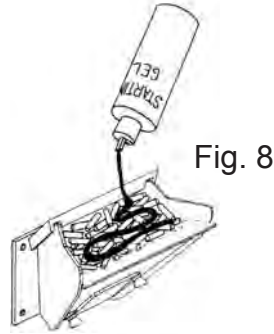

Fig. 8

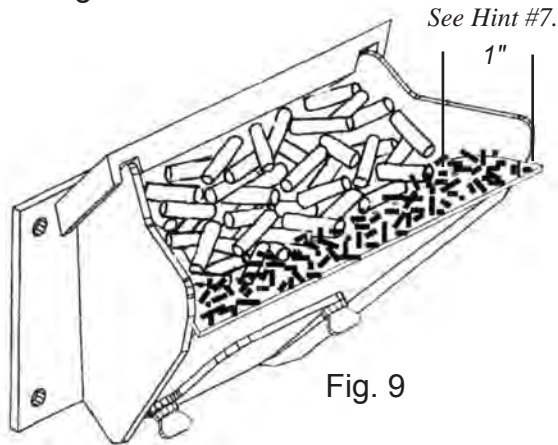

Fig. 9

#### Helpful Hints:

1. Fines are small pieces of broken pellets (sawdust). Fines do not flow easily and often build up on the hopper funnel bottom angles. These fines can be pushed into the feeder opening and then fill the hopper with pellets. As the system works, they will be burned.
2. The "TEST" cycle will operate the feeder motor for exactly one minute. Turning to "TEST" again and again may feed too much fuel into the burn pot causing excessive smoke on start-up.
3. The firebox low pressure switch will not allow the auger motor or the igniter element to operate if the view door or the ash pan door are open.
4. Adjust Feed Rate. If this is your first fire or you are trying different pellets, set the feed adjuster to #4, Fig. 7. This is a conservative number and will probably need to be increased. After you know a feed rate setting that works well, use that setting. Remember, if your feed rate is too high you may waste fuel.
5. This is usually a weekly maintenance procedure. Cleaning the burn pot with the scraper with a small amount of new fuel in the bottom is not a problem. First, scrape the ashes on the front of the burn pot into the ash pan. Then scrape the holed surface downward into the burn pot. When the stove is ignited these scrapings will be pushed out by the feeder.
6. The ash pan can hold the ashes from approximately 1 ton of premium fuel. This means the ashes will only need to be emptied a few times a year.
7. Setting the feed adjuster # for maximum burn: With the unit burning in "AUTO", turn to "Stove Mode" and put the fan on "H". Set the Temperature Dial to #7. Allow the unit to burn for about 30 minutes and check ash on front of burn pot. Fig. 9. If the ash line is larger than 1", turn the feed adjuster from #4 to #5. Allow another 30 minutes of burn time and check again. If, at #6 setting, a 1" or less ash bed is not obtainable, it is not a problem. The 1" ash bed is only a maximum burn rate and at most normal settings the ash bed will be larger.

## Starting First Fire

### Igniter Switch to "MANUAL" (up position)

Make sure the unit is plugged into a 120 VAC, 60 HZ electrical source. The power light should be the only light lit.

**IMPORTANT:** To avoid unwanted smoke, Be sure there is no fuel or other combustibles in the ash pan prior to lighting.

Keep all doors closed during operation. Maintain all seals and gaskets in good condition.

1. Turn **FEED ADJUSTER** to the desired feed rate. No. 4 is good for most pellets.<sup>4</sup>
2. Turn the **MODE SELECTOR** to "OFF" and then to the desired mode. This will reset the control and start the combustion motor.
3. Turn the **TEMPERATURE DIAL** to the desired setting.
4. Clean the burn pot with the scraper, if necessary.<sup>5</sup>
5. Fill the burn pot with pellets, only level with front edge. (Do Not Over Fill).
6. Add starting gel on top of the pellets. Stir the gel into pellets for faster lighting.
7. Light the starting gel with a match, and close the door. Operation will begin when the fire reaches the proper temperature.<sup>3</sup>
8. Fill the hopper with pellets and remove ashes as required.<sup>1, 6</sup>

## Warning

**NEVER USE GASOLINE, GASOLINE-TYPE LANTERN FUEL, KEROSENE, CHARCOAL LIGHTER FLUID, OR SIMILAR LIQUIDS TO START OR 'FRESHEN UP' A FIRE IN THIS HEATER. KEEP ALL SUCH LIQUIDS WELL AWAY FROM THE HEATER WHILE IN USE.**



When installing and operating your Harman Accentra Pellet Stove, respect basic safety standards. Read these instructions carefully before you attempt to install or operate the Accentra. Failure to do so may result in damage to property or personal injury and may void the product warranty.

Several issues must be addressed when selecting a suitable location for your Accentra Pellet Stove. Observing required clearances to combustible materials, the proximity to a safe chimney or venting system, and the accessibility of electrical supply must all be considered. In addition, selecting a location that takes advantage of the building's natural air flow is also desirable to maximize the heating effectiveness of the heater. In many cases, this is a central location within the building.

Place the stove on a noncombustible floor surface or floor protector. This can be a minimum of a 20 gauge sheet metal plate, ceramic tile with grouted joints, a UL listed stove board, or a Harman Cast Iron floor protector<sup>1</sup>. The Harman Cast Iron Floor Protector is equal to the minimum dimensions (**USA only**), which are  $24\frac{1}{16} \times 28\frac{5}{8}$ . This allows for a 2" extension on each side of the unit (which is actually **6 inches from the window** opening) and a 6" extension to the front (measured **from the window** opening also) ( $3\frac{3}{8}$ "<sup>2</sup> if measured from the base plate front edge.) The rear edge of the floor protection can be flush with the cast base plate rear edge.

**In Canada, floor protection must extend 8" (20cm) to the sides and 18" (46cm) in front, each measured from the window opening.**

Place the stove away from combustible walls at least as far as shown in figures 10, 11, & 13. Minimum clearance to a ceiling above the heater is 24".

Note that the clearances shown are minimum for safety but do not leave much room for access when cleaning or service is needed.

**DO NOT CONNECT THIS ROOM HEATER TO ANY AIR DISTRIBUTION DUCT OR SYSTEM.**

**INSTALL VENT AT CLEARANCES SPECIFIED BY THE VENT MANUFACTURER.**

**DO NOT USE MAKESHIFT COMPONENTS OR COMPROMISES WHEN INSTALLING THIS APPLIANCE. YOUR SAFETY IS A SERIOUS CONCERN.**

## CAUTION

The stove is hot while in operation.  
Keep children, clothing and furniture away.  
Contact may cause skin burns.

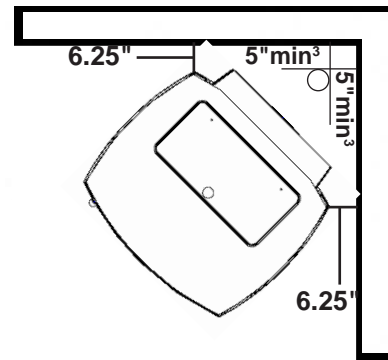

Fig. 10

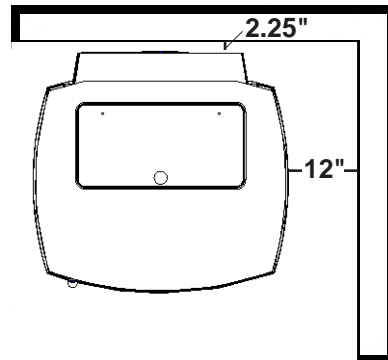

Fig. 11

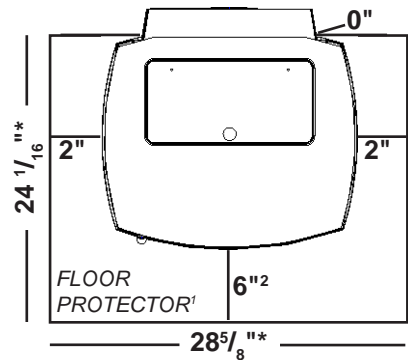

Fig. 12

(\*Harman Cast Iron Floor Protector size. Approved for use in the USA only.)

*This is the minimum size Harman recommends for the alcove with a 60" ceiling.*

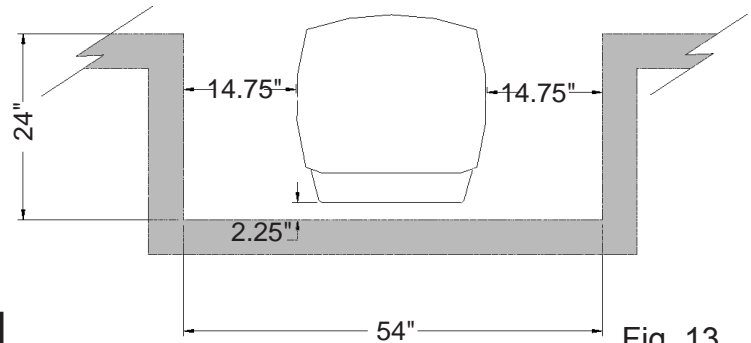

Fig. 13

1. Check your local codes to see if protection is required under the flue pipe.
2. This measurement equals 6" from inside edge of ash door opening.
3. 5" pipe clearance to wall in a corner installation.

**IMPORTANT NOTE:** The Accentra is shipped bolted to the skid through two holes in the cast base plate. If these holes are not used to lag the unit to the floor these holes must be filled with the 3/8" x 1/2" hex head bolts provided. (See tag on bolt bag provided.)

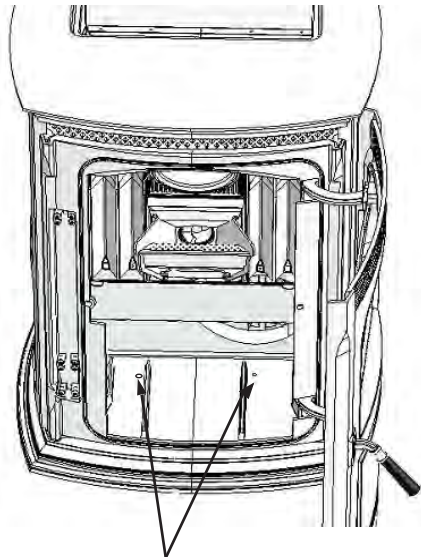

Fig. 14

*Skid bolt down holes/floor lag down holes*

### Optional Rubber Pad Leveling Feet

Optional kit #1-00-12302 contains 4 rubber pad feet. Used to raise the bottom edge of the cast base plate off the floor surface, they ensure that any vibrations caused by motors and other moving parts will not be transferred by direct contact. These rubber pads have a threaded stud that extends through the base plate. The top of the threaded stud has a screwdriver slot. Therefore, the unit can be leveled from above inside the unit. The front two are in the right and left front corners of the firebox. **NOTE:** The door will need to be partially closed to access the right leveling pad stud due to the door hinge.

The rear two studs are to the right and left of the distribution blower. They are somewhat difficult to reach, therefore, it is suggested that the rear two pads be adjusted by tilting the unit slightly forward. Adjust the pads with your fingers and tilt unit back for fit. Then adjust the front pads for the final clearance.

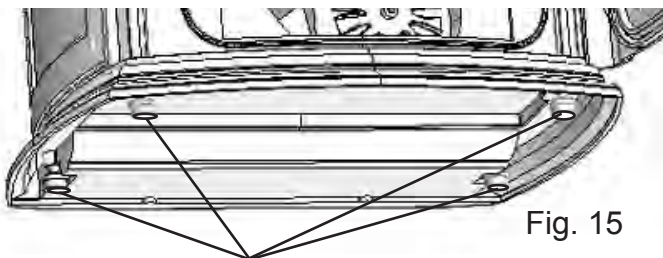
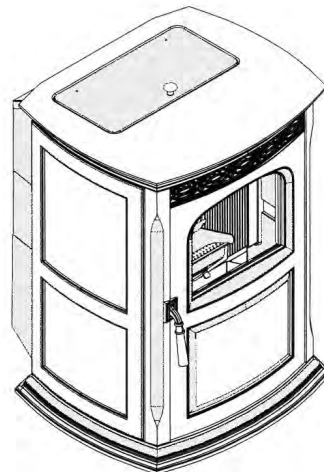

Fig. 15

*Leveling/vibration-dampening feet*

### Optional Leg Kit

There is a leg kit available for the Accentra (Item # 1-00-247211). The four cast iron legs bolt to a plate, and the stove then sits on the plate. The rubber leveling feet are removed to allow the stove to fit down over the leg plate. The leg kit adds 2.95 inches in height. The leg kit can also be used in conjunction with the cast floor protector. If using with the cast floor protector, a floor protector cover is also needed since the legs allow viewing underneath the stove.



*Leg Kit includes; four legs, mounting plate and hardware.*

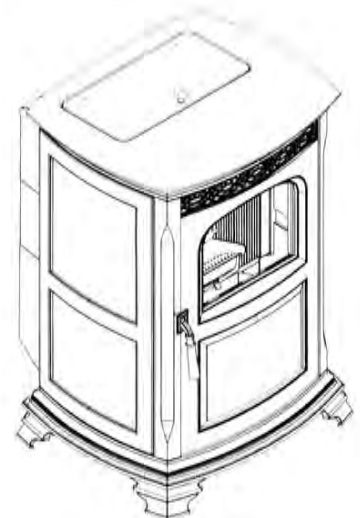
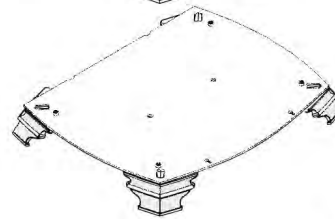

**DO NOT BLOCK OR OBSTRUCT THE AREA BENEATH THE APPLIANCE. THIS AIRFLOW IS CRUCIAL TO SAFE OPERATION AND CLEARANCES TO COMBUSTIBLES.**

When installing the Accentra in a mobile home several requirements must be followed:

1. The unit must be bolted to the floor. This can be done with 1/4" lag screws through the 2 holes in the base plate shown in Fig. 16
2. The unit must also be connected to outside air. See page 14.
3. Floor protection and clearances must be followed as shown on page 9.
4. Unit must be grounded to the metal frame of the mobile home.

**CAUTION: This appliance must be vented to the outside.**

Due to high temperatures, the Accentra should be placed out of traffic and away from furniture and draperies.

Children and adults should be alerted to the hazards of high surface temperatures and should stay away to avoid burn to skin and/or clothing.

Young children should be carefully supervised when they are in the same room as the stove.

Clothing and other flammable materials should not be placed on or near the Accentra Pellet Stove.

Installation and repair of the Accentra Pellet Stove should be done by a qualified service person. The appliance should be inspected before use and at least annually by a qualified service person. More frequent cleaning will be required. It is imperative that control compartments, burners, and circulating air passage-

**MOBILE/MANUFACTURED HOME REGULATIONS DO NOT ALLOW INSTALLATION IN ROOMS DESIGNATED FOR SLEEPING.**

**MOBILE HOME INSTALLATION SHOULD BE DONE IN ACCORDANCE WITH THE MANUFACTURED HOME AND SAFETY STANDARD (HUD), CFR 3280, PART 24.**

**AFTER THE INSTALLATION IS COMPLETE**

Before the first fire is lit, check and record the high and low draft reading numbers on page 12. Make adjustments to the low draft at this time, if necessary.

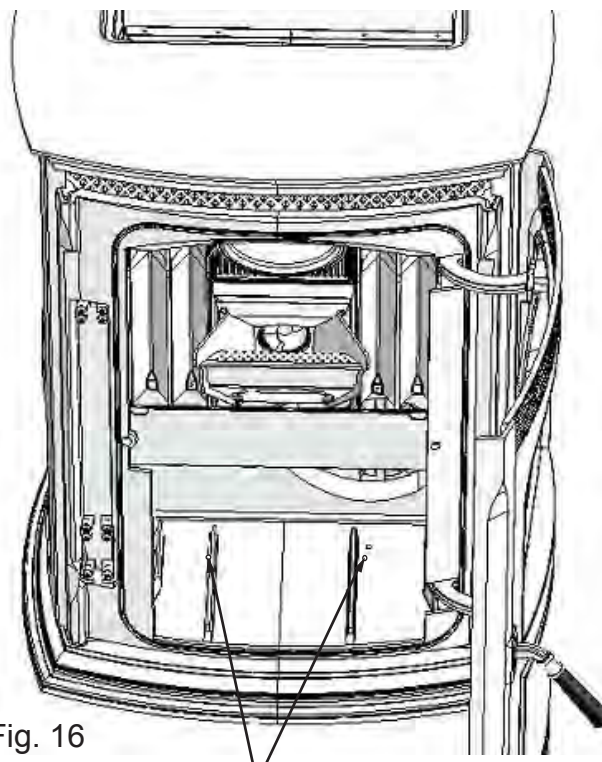

Fig. 16

*Unit bolt down holes for mobile home installation lag to floor with 1/4" diameter lag bolts with washer. (not supplied.) Note: If the optional leg kit is used, a longer bolt will be required.*

**CAUTION**

THE STRUCTURAL INTEGRITY OF THE MOBILE HOME FLOOR, WALL, AND CEILING/ROOF MUST BE MAINTAINED.

**CAUTION**

THE STOVE IS HOT WHILE IN OPERATION. KEEP CHILDREN, CLOTHING AND FURNITURE AWAY. CONTACT MAY CAUSE SKIN BURNS.

**WARNING**

KEEP COMBUSTIBLE MATERIALS SUCH AS GRASS, LEAVES, ETC. AT LEAST 3 FEET AWAY FROM THE POINT DIRECTLY UNDER THE VENT TERMINATION.



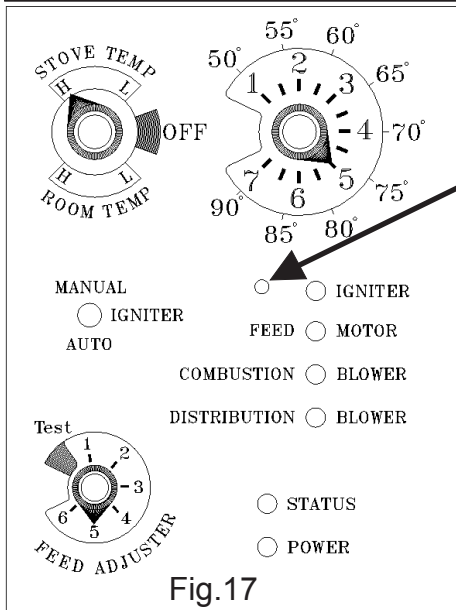

Fig.17

**Combustion Motor Speed Control Low draft only set point.**  
*The small straight screwdriver slot is plastic; therefore, the unit can be adjusted while in operation.*

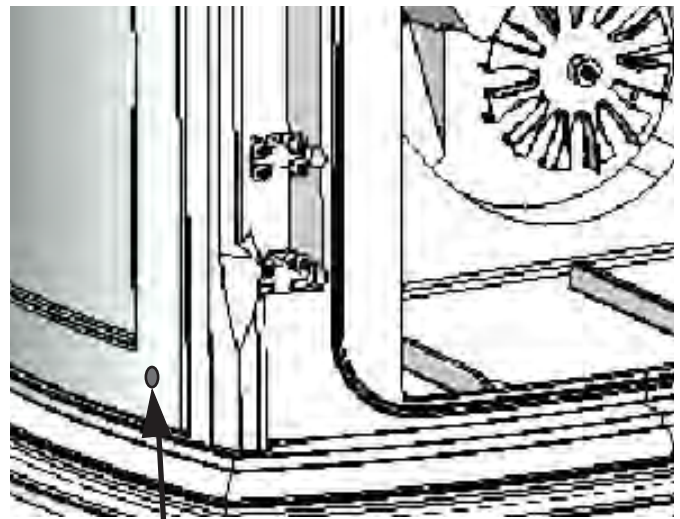

Fig. 18

Draft Meter bolt hole location

These units are pre-tested at the factory with exactly 120 Volts AC, 60 Hz. They are checked and adjusted for firebox tightness, gasket leakage, motor operation and igniter operation. The Accentra is then factory set at a high adjustment. **NOTE: Low draft adjustment may be required. The factory low draft setting may not be correct for the units permanent installation conditions.**

The control board on the Accentra is equipped with a low draft adjustment port. Located on the control face just to the left of the igniter light. See Figure 17. This voltage adjustment is provided to allow the unit to be adjusted for the household voltage where the unit is going to be in permanent operation. **NOTE:** The line voltage varies from area to area and often home to home.

The low draft voltage should be adjusted to achieve the most efficient burn on low burn or "maintenance". This voltage adjustment allows the installer to change the low voltage set point approximately 15 volts. This adjustment should be done by the installer during set up because a draft meter reading is required to ensure proper set up.

If the unit is not adjusted properly, it does not cause a safety concern. If the unit is adjusted too high, only efficiency is lost. If the unit is adjusted too low, the low draft pressure switch will not allow the feeder motor or the igniter to operate.

A simple draft test should be performed after completing the flue pipe installation. Record the results for future reference:

1. Plug unit into a 120 VAC, 60 HZ outlet.
2. Close the hopper lid and front view door. Neither pellets or a fire are required for this test.
3. With the mode selector in the "OFF" position, turn the feed adjuster to "TEST".
4. Record the high draft \_\_\_\_\_ in. W.C. (Normal is -.45 to -.55) The control will be on the High Draft for a total of 2 minutes.
5. After 2 minutes, the combustion motor will go down to low draft and the distribution blower will go on high. Allow approximately 15 seconds to pass for the combustion motor to slow before checking the low draft.
6. If the low draft is between .30 and .35, record the reading \_\_\_\_\_ in. W.C. If the reading is higher, slowly turn the set screw counter-clockwise until the draft lowers. If the reading is lower, very slowly turn the set screw clockwise until the draft increases.

**NOTE: The test mode alternates from high to low draft every 60 seconds. If more time is needed for draft adjustment, wait until the next low draft cycle.**

**NOTE: In some cases, the draft may not go as low as .30 even with the set screw completely counter-clockwise.**



## Room Sensor Installation



Fig. 19

The room sensor is a small temperature sensor on the end of a 60" wire. This sensor is installed much like a standard wall thermostat. Because it is so small, it can be hidden along the trim of a doorway or even up the leg of a coffee table. There is a remote room sensor port on the rear of the unit for easy external connection. Use standard 18-2 thermostat wire to extend the distance to the desired location (100' maximum). The room sensor should be installed in the location where you want to control the temperature.

**NOTE:** Distances of more than 25 feet from the unit or in another room are not recommended. The room sensor is essential for the Accentra's excellent efficiency.

**It is recommended that the room sensor be installed,** even if only installed on the rear of the unit as a return air sensor. There is an intake screen on the bottom of the rear sheet metal enclosure. This is an ideal place to tie wrap the sensor head to sense return air temperature.

## Rear Shields

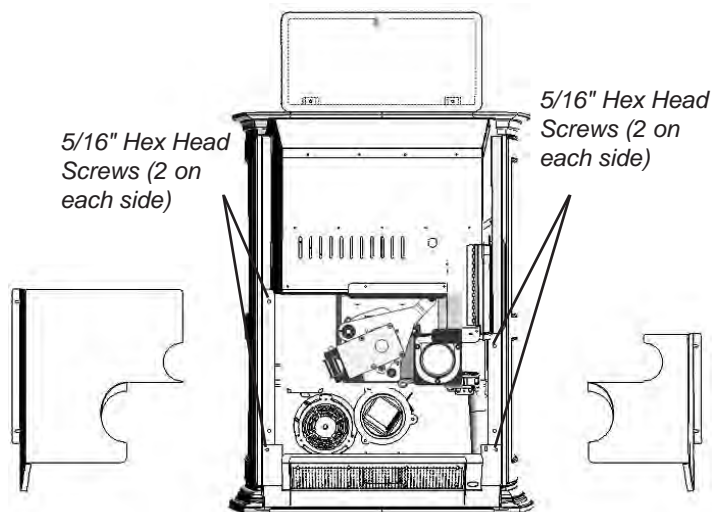

Fig. 20

The rear insulated shields are split in the middle for easy removal. Each shield has two 5/16" hex head screws that only need to be loosened (NOT REMOVED) to allow the shield to slide away from the unit. **NOTE: It is not recommended that the unit be operated with the shields removed, due to the hot and moving parts which they protect.**

## REMINDERS

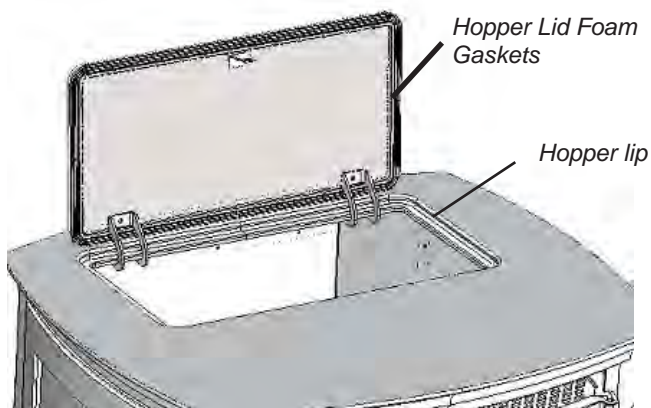

Fig. 21

Do not allow pellets or sawdust to build up on the hopper lip.

Inspect the hopper lid gasket for damage. A good hopper lid seal is very important for proper operation.

There is also a switch to determine the positioning of the hopper lid. If the lid is not closed properly, the feed motor and igniter will be disabled. (See wiring diagram)

**IMPORTANT NOTICE**

3 or 4 inch Pellet Vent Pipe -  
Type L or PL Must be used.

Fig.22

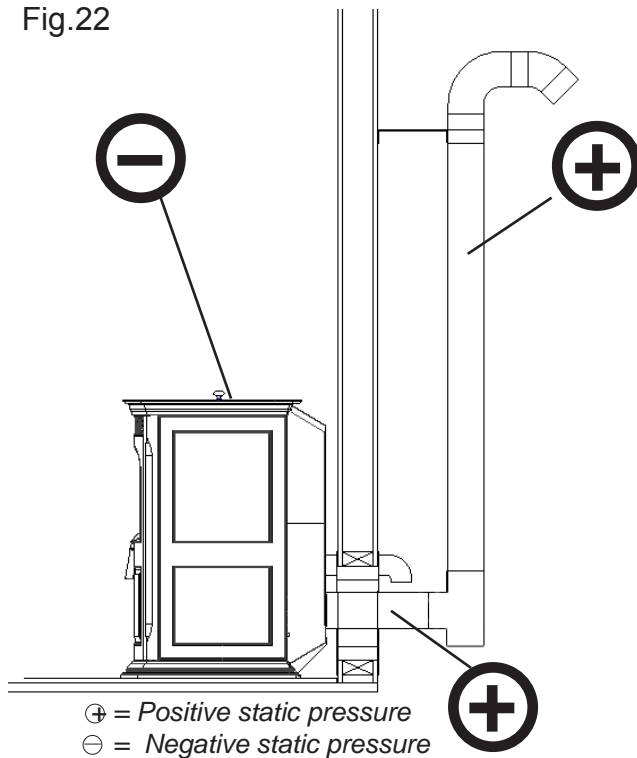
**Venting**

A combustion blower is used to extract the combustion gases from the firebox. This causes a negative pressure in the firebox and a positive pressure in the venting system as shown in fig. 22. The longer the vent pipe and more elbows used in the system, the greater the flow resistance. Because of these facts we recommend using as few elbows as possible and 15 feet or less of vent pipe. The maximum horizontal run should not exceed 48". If more than 15 feet of pipe is needed, the diameter should be increased from 3" to 4" because a larger pipe causes less flow resistance. **Be sure to use approved pellet vent pipe wall and ceiling pass-through fittings to go through combustible walls and ceilings.** Be sure to use a starting collar to attach the venting system to the stove. **The starting collar must be secured to the heater with a minimum of two fasteners.** The screws provided are a self-drilling type of screw. However, due to material thickness, drilling a 3/32" pilot hole is recommended for each screw. You may also wish to seal this connection with RTV silicone caulking.

**Vent Pipe**

Pellet venting pipe (also known as L or PL vent) is constructed of two layers with air space between the layers. This air space acts as an insulator and reduces the outside surface temperature to allow a clearance to combustibles of only 3 inches. The sections of pipe lock together to form an air tight seal in most cases; however, in some cases a perfect seal is not achieved. For this reason and the fact that the Accentra operates with a positive vent pressure, **we specify that the joints also be sealed with high-temp silicone.**

**Outside Air**

Connection to outside air is strongly recommended. It is required for all mobile home installations, and where building codes require.

To install outside air use 2 3/8" I.D. flex pipe, part number 1-00-08543 (25 feet). There is a break-away hole on the rear panel which must be removed before connecting the flex pipe. The pipe should be run outside and terminate to the side or below the vent pipe outlet so the flue outlet is more than 12" from the inlet cover. The maximum length run of this pipe is 15 feet. If a longer run is needed, the size must be increased to 3". Inlet cover part number 1-10-08542 should be used to keep birds, rodents, etc. out of the pipe.

You may choose to use the optional Direct Vent Wall Passthrough Kit (part #1-00-677077) which incorporates venting passthrough and outside air into one component. See Fig. 24b.

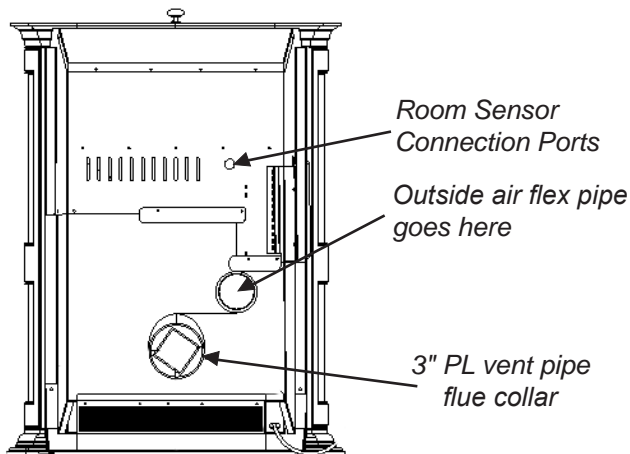

Fig. 23

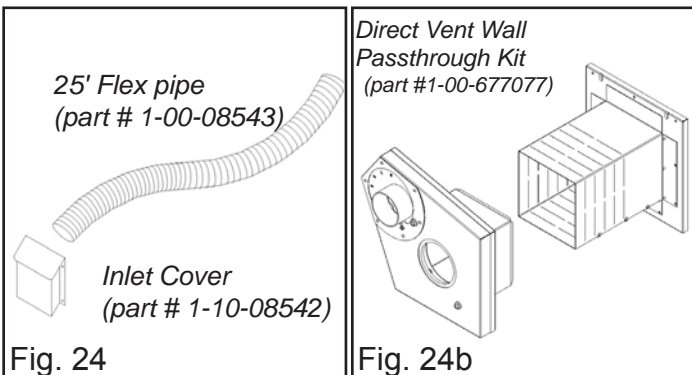

Fig. 24

Fig. 24b

## Avoiding Smoke and Odors

### Negative Pressure, Shut-down, and Power Failure:

To reduce the probability of back-drafting or burn-back in the pellet burning appliance during power failure or shut-down conditions, the stove must be able to draft naturally without exhaust blower operation. Negative pressure in the house will resist this natural draft if not accounted for in the pellet appliance installation.

Heat rises in the house and leaks out at upper levels. This air must be replaced with cold air from outdoors, which flows into lower levels of the house. Vents and chimneys into basements and lower levels of the house can become the conduit for air supply, and reverse under these conditions.

### Outside Air:

Harman Home Heating and Hearth & Home Technologies **strongly** recommend attaching outside air in all installations, especially lower level and main floor locations.

Per national building codes, consideration must be given to combustion air supply to all combustion appliances. Failure to supply adequate combustion air for all appliance demands, may lead to back-drafting of those and other appliances.

When the appliance is side-wall vented: The air intake is best located on the same exterior wall as the exhaust vent outlet and located lower on the wall than the exhaust vent outlet.

When the appliance is roof vented: The air intake is best located on the exterior wall oriented towards the prevailing wind direction during the heating season.

The outside air connection will supply the demands of the pellet appliance, but consideration must be given to the total house demand. House demand may consume some air needed for the stove, especially during a power failure. It may be necessary to add additional ventilation to the space in which the pellet appliance is located. Consult with your local HVAC professional to determine the ventilation demands for your house.

### Vent Configurations:

To reduce probability of reverse drafting during shut-down conditions, Hearth & Home Technologies strongly recommends:

- Installing the pellet vent with a minimum vertical run of five feet, preferably terminating above the roof line.
- Installing the outside air intake at least four feet below the vent termination.

To prevent soot damage to exterior walls of the house and to prevent re-entry of soot or ash into the house:

- Maintain specified clearances to windows, doors, and air inlets, including air conditioners.
- Vents should not be placed below ventilated soffits. Run the vent above the roof.
- Avoid venting into alcove locations.
- Vents should not terminate under overhangs, decks or onto covered porches.
- Maintain minimum clearance of 12 inches from the vent termination to the exterior wall. If you see deposits developing on the wall, you may need to extend this distance to accommodate your installation conditions.

**Hearth & Home Technologies assumes no responsibility for, nor does the warranty extend to, smoke damage caused by reverse drafting of pellet appliances under shut-down or power failure conditions.**

**DO NOT INSTALL A FLUE DAMPER IN THE EXHAUST VENTING SYSTEM OF THIS APPLIANCE.**

**DO NOT CONNECT THIS UNIT TO A CHIMNEY FLUE SERVING ANOTHER APPLIANCE.**

**CHIMNEY CONNECTOR MAY NOT PASS THROUGH AN ATTIC OR ROOF SPACE, CLOSET OR SIMILAR CONCEALED SPACE, OR A FLOOR OR CEILING.**

**DO NOT CONNECT THIS APPLIANCE TO ANY AIR DISTRIBUTION DUCT OR SYSTEM.**

### #1 Preferred method

This method provides excellent venting for normal operation and allows the stove to be installed closest to the wall. Two and a half inches from the wall is safe; however, three inches allows better access to remove the rear panel. The vertical portion of the vent should be three to five feet high. This vertical section will provide natural draft in the event of a power failure. **Note: Do not place joints within wall pass-throughs.**

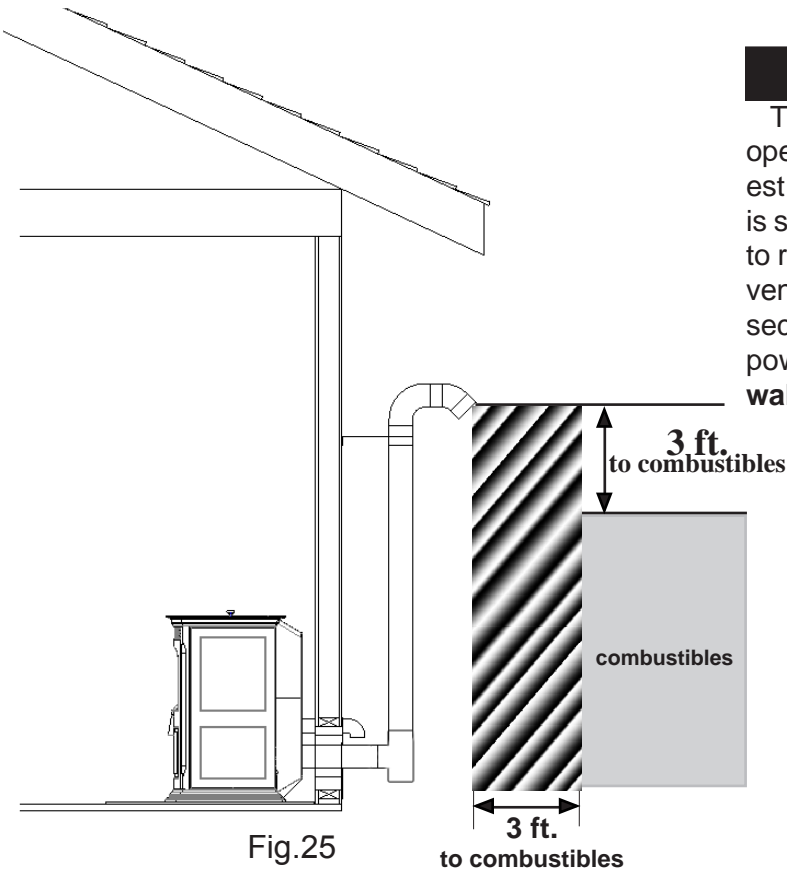

### #2 Preferred method

This method also provides excellent venting for normal operation but requires the stove to be installed farther from the wall. The vertical portion of the vent should be three to five feet high and at least three inches from a combustible wall. This vertical section will provide natural draft in the event of a power failure. **Note: Do not place joints within wall pass-throughs.**

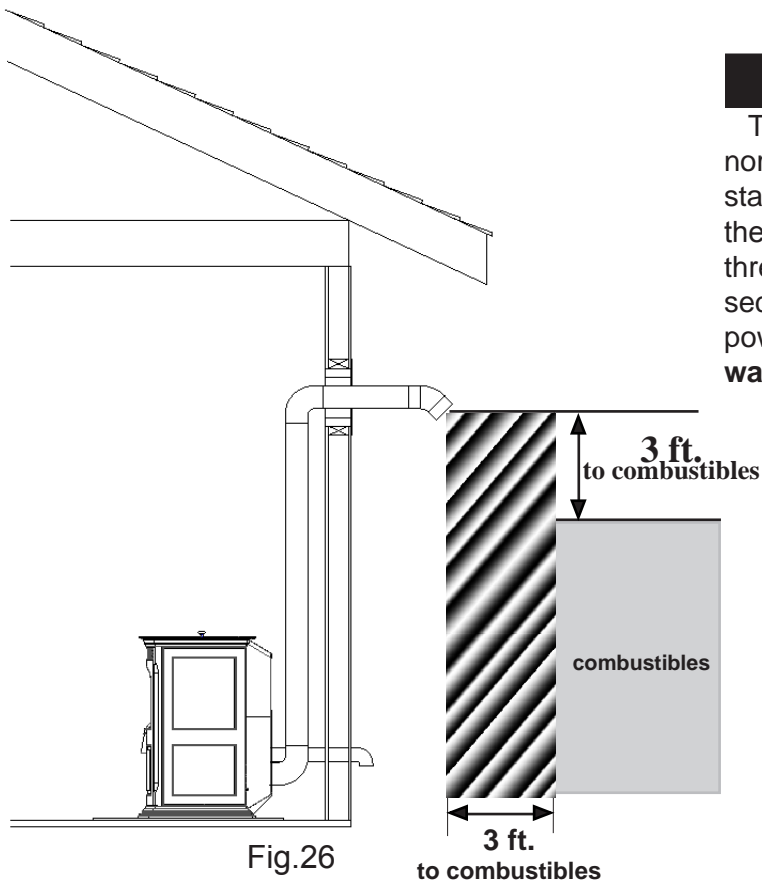

### CAUTION

KEEP COMBUSTIBLES (SUCH AS GRASS, LEAVES, ETC.) AT LEAST 3 FEET AWAY FROM THE FLUE OUTLET ON THE OUTSIDE OF THE BUILDING.



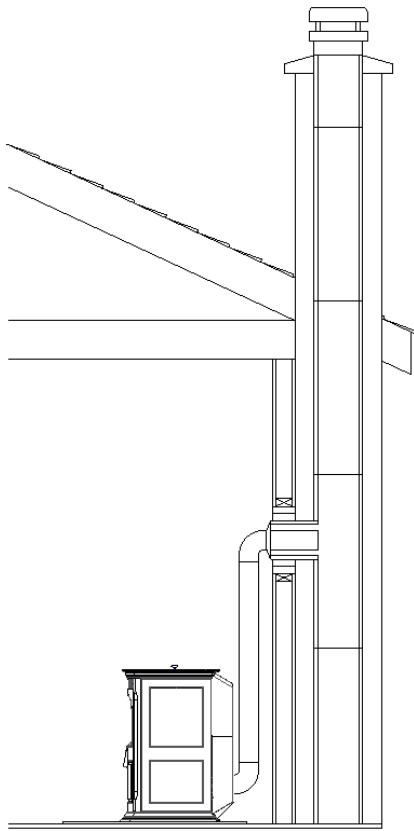

Fig.27

#### #4 Installing into an existing chimney

This method provides excellent venting for normal operation. Check your local code requirements. Some areas require that a liner be installed to the top of the flue, as shown in method #7. This method will provide natural draft in the event of a power failure. If the chimney condition is questionable or if the flue size is larger than 8 X 8 inches, you should refer to method #7. If choosing this method, increase the vent pipe to 4 in. at the stove.

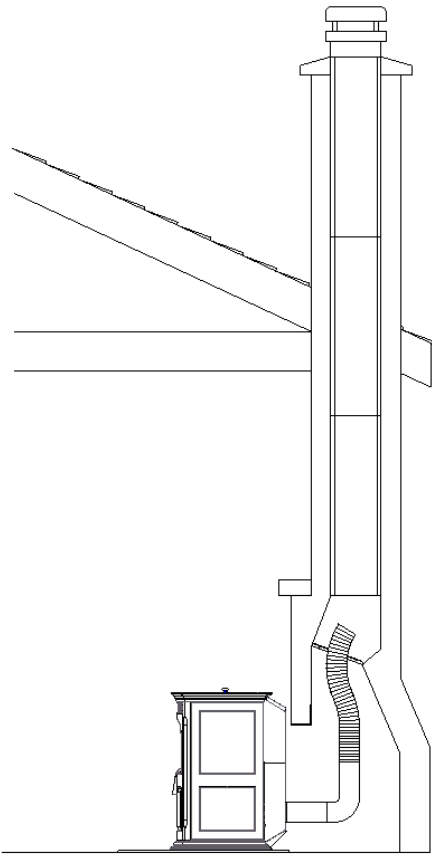

Fig.28

#### #5 Installing into an existing fireplace chimney

This method provides excellent venting for normal operation. Check your local code requirements. Some areas require that a liner be installed to the top of the flue, as shown in method #6. This method also provides natural draft in the event of a power failure.

The damper area must be sealed with a steel plate (not supplied). Kaowool, mineral wool, or an equivalent non-combustible insulation is recommended to be installed on top of the sealing plate. This will help to reduce condensation. A cap should be installed on the chimney to keep out rain. If the chimney condition is questionable or if the flue size is larger than 8 X 8 inches, you should refer to Method #6. If choosing this method, increase the vent pipe diameter to 4 inches at the stove.

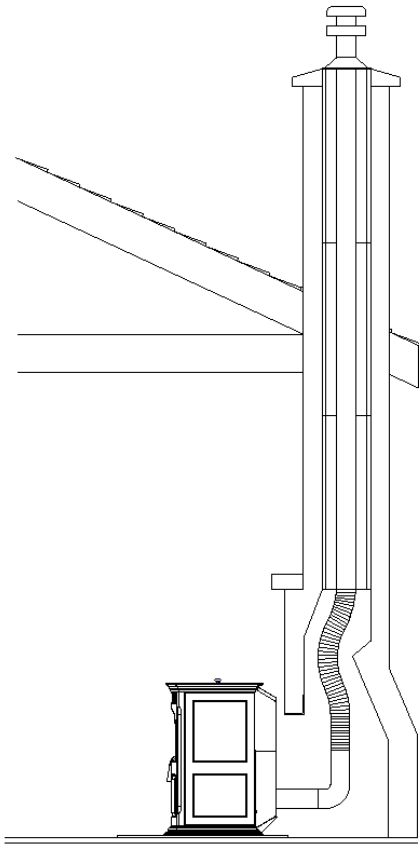

Fig.29

### #6 Installing into an existing fireplace chimney

This method provides excellent venting for normal operation. This method also provides natural draft in the event of a power failure.

Some places in the US and Canada, it is required that the vent pipe extend all the way to the top of the chimney.

In this method a cap should also be installed on the chimney to keep out rain. Be sure to use approved pellet vent pipe fittings. Seal pipe joints with silicone in addition to the sealing method used by the manufacturer. Pipe size should be increased to 4" using this method.

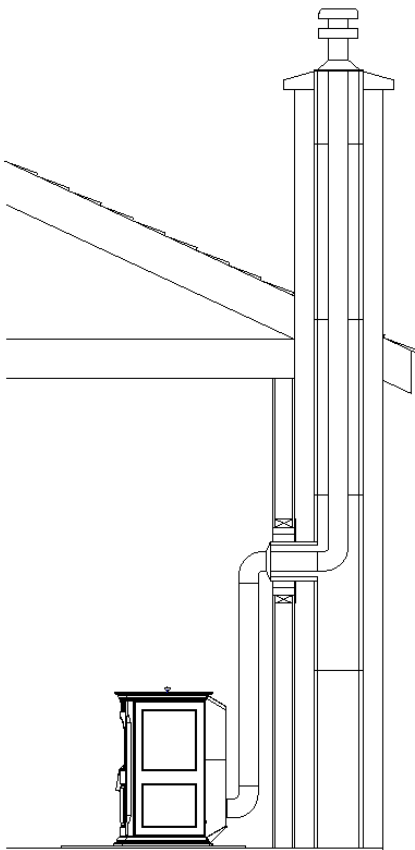

Fig.30

### #7 Installing into an existing chimney

This method provides excellent venting for normal operation. This method also provides natural draft in the event of a power failure.

Some places in the US and Canada, it is required that the vent pipe extend all the way to the top of the chimney. The pipe or liner inside the chimney should be 4" diameter and approved for pellet venting.

In this method a cap should also be installed on the chimney to keep out rain.

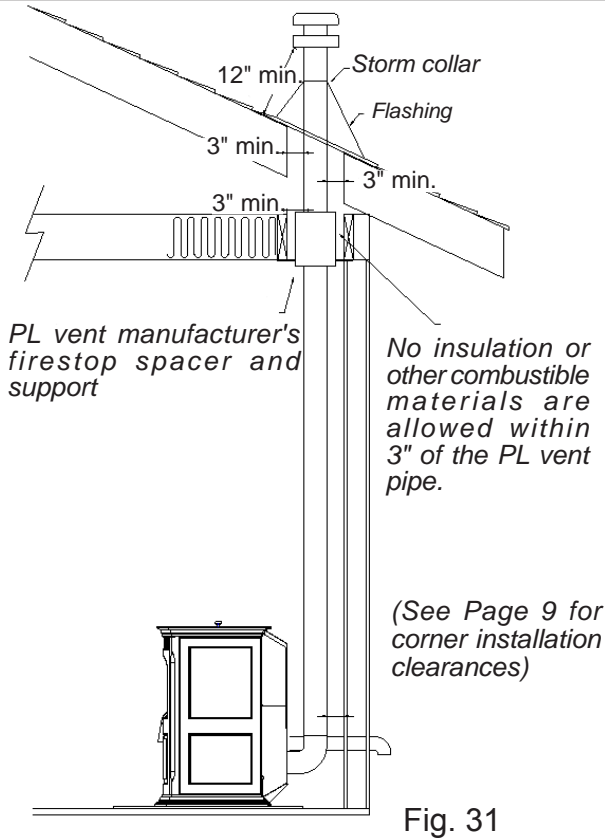

### Minimum flue vent configuration

It is required that outside air be installed with this venting configuration to reduce smoke and creosote smell in the room in the event of power failure.

Fig. 32

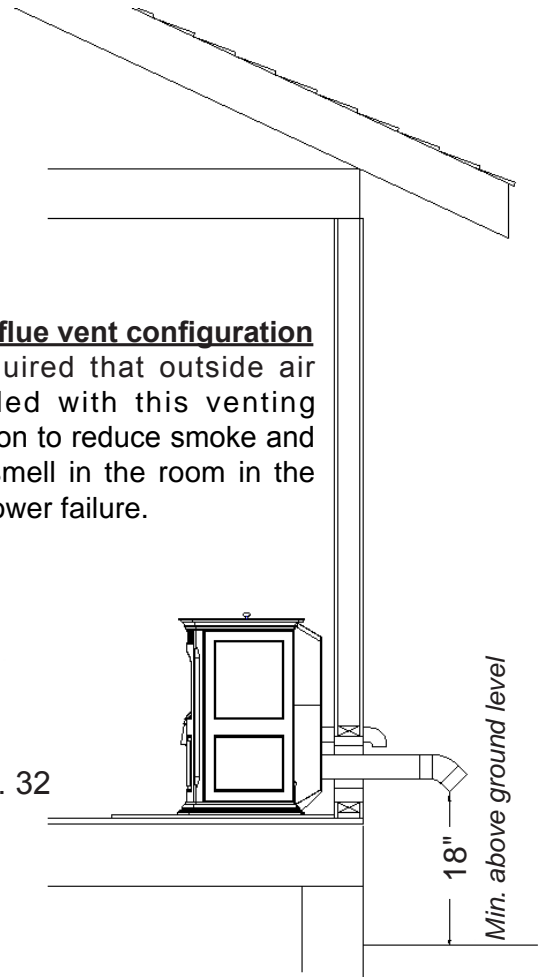

## #8 Installing through the ceiling vent

Through the ceiling vent, follow PL vent manufacturers recommendations when using wall and ceiling pass through. **Note: Do not place joints within wall pass-throughs.**

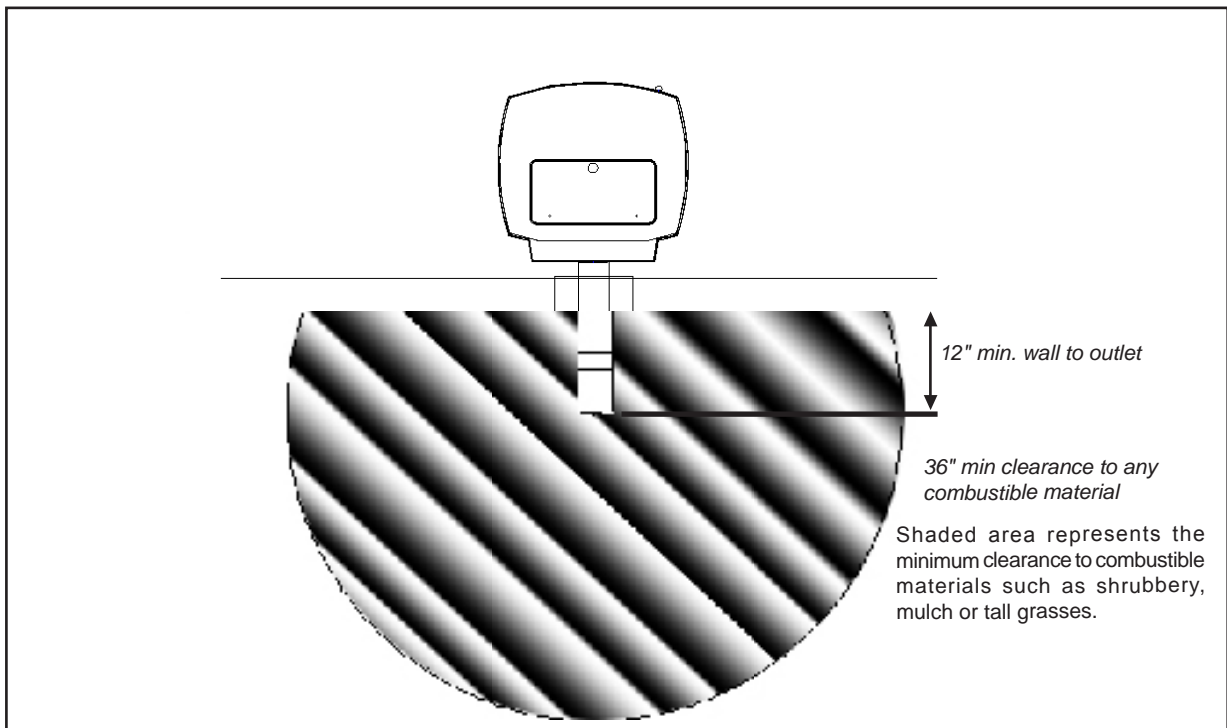

### Requirements for Terminating the Venting

**WARNING:** Venting terminals must not be recessed into a wall or siding.

**NOTE:** Only "pellet" vent pipe wall pass-throughs and fire stops should be used when venting through combustible materials.

**NOTE:** Always take into consideration the effect the prevailing wind direction or other wind currents will cause with flyash and/or smoke when placing the termination.

#### In addition, the following must be observed:

A. The clearance above grade must be a minimum of 18".<sup>1</sup>

B. The clearance to a window or door that may be opened must be a minimum of 48" to the side and 48" below the window/door, and 12" above the window/door. <sup>1</sup>

**With outside air installed, the clearances are 18" to the side and below and 9" above.**

C. A 12" clearance to a permanently closed window is recommended to prevent condensation on the window.

D. The vertical clearance to a ventilated soffit located above the terminal within a horizontal distance of 2 feet (60 cm) from the center-line of the terminal must be a minimum of 18".

E. The clearance to an unventilated soffit must be a minimum of 12".

F. The clearance to an outside corner is 11" from center of pipe.

G. The clearance to an inside corner is 12".

H. A vent must not be installed within 3 feet (90cm) above a gas meter/regulator assembly when measured from the horizontal center-line of the regulator.<sup>1</sup>

I. The clearance to service regulator vent outlet must be a minimum of 6 feet.<sup>1</sup>

J. The clearance to a non-mechanical air supply inlet to the building or the combustion air inlet to any other appliance must be a minimum of 48".<sup>1</sup>

K. The clearance to a mechanical air supply inlet must be a minimum of 10 feet.<sup>1</sup>

**(with outside air installed, 6 feet )**

L. The clearance above a paved sidewalk or a paved driveway located on public property must be a minimum of 7 feet.<sup>1,2</sup>

M. The clearance under a veranda, porch, deck or balcony must be a minimum of 12 inches.<sup>1,3</sup> **(B Also Applies)**

**NOTE:** The clearance to vegetation and other exterior combustibles such as mulch is 36" as measured from the center of the outlet or cap. This 36" radius continues to grade or a minimum of 7 feet below the outlet.

<sup>1</sup>Certain Canadian and or Local codes or regulations may require different clearances.

<sup>2</sup>A vent shall not terminate directly above a sidewalk or paved driveway which is located between two single family dwellings and serves both dwellings.

<sup>3</sup>Only permitted if veranda, porch, deck, or balcony is fully open on a minimum of 2 sides beneath the floor.

**NOTE: Where passage through a wall, or partition of combustible construction is desired, the installation shall conform to CAN/CSA-B365. (if in Canada)**

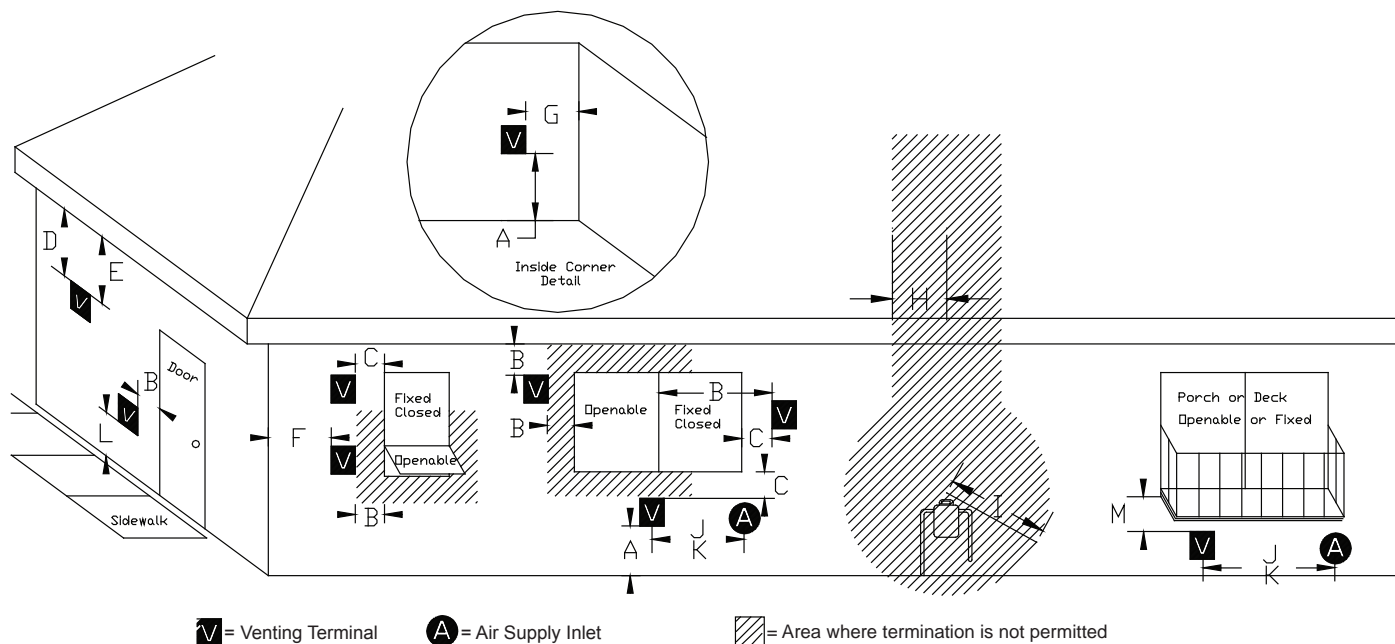



The glass used in your stove is manufactured to exact standards to withstand the high heat of the fire, but like all glass, it must be treated with common sense and care. Never abuse the glass by slamming the door shut or striking the glass with a heavy object. If the glass is broken or damaged, do not operate the stove until it has been replaced.

### Glass - Replacement

If the stove's glass is cracked or broken, you must replace it before operating your stove. Remove pieces carefully. Replace glass only with Harman replacement glass; **do not use substitutes.**

Carefully remove damaged glass, gasket material, and hold down clips (set aside).

Install the self adhesive 1/4" gasket material around the front face of the glass. Set the glass panel and gasket gently onto the door. Install the hold down clips and tighten with bolts.

### Glass - Cleaning

Sometimes it will be necessary to clean accumulated ash from the glass surface; allowing this ash to remain on the glass for long periods can result in "etching" due to the acidity of the ash. Never clean the glass while it is hot, and **do not** use abrasive substances. Wash the surface with cool water, and rinse thoroughly. You may wish to use a non-abrasive cleaner specifically designed for use on stove glass. In any case, dry thoroughly before relighting your stove.

### Creosote - Formation and Need for Removal -

When wood is burned slowly, it produces tar and other organic vapors, which combine with expelled moisture to form creosote. The creosote vapors condense in the relatively cool chimney flue of a slow-burning fire. As a result, creosote residue accumulates on the flue lining. When ignited, this creosote makes an extremely hot fire. The pellet vent pipe should be inspected at least twice monthly during the heating season to determine if a creosote buildup has occurred. If creosote has accumulated it should be removed to reduce the risk of a chimney fire.

*Guidance on minimizing creosote formation and the need for periodic creosote removal:* The chimney should be inspected during the heating season to determine if a creosote build-up has occurred. If a significant layer of creosote has accumulated, 1/8" (3mm) or more, it should be removed to reduce the risk of a chimney fire.

**Soot and Flyash: Formation and Need for Removal-** The products of combustion will contain small particles of flyash. The flyash will collect in the exhaust venting system and restrict the flow of exhaust gases. Incomplete combustion, such as occurs during start-up and shut-down, or incorrect operation of the appliance, will lead to soot formation in the venting system. The stove and the entire venting system should be professionally inspected and cleaned at least once per year, aside from the regular cleanings. Most retailers offer a cleaning service for their customers. The best time to have this cleaning performed is after the heating season.

*Inspect the hopper lid sponge gasket. It is important to maintain a good hopper lid seal.*

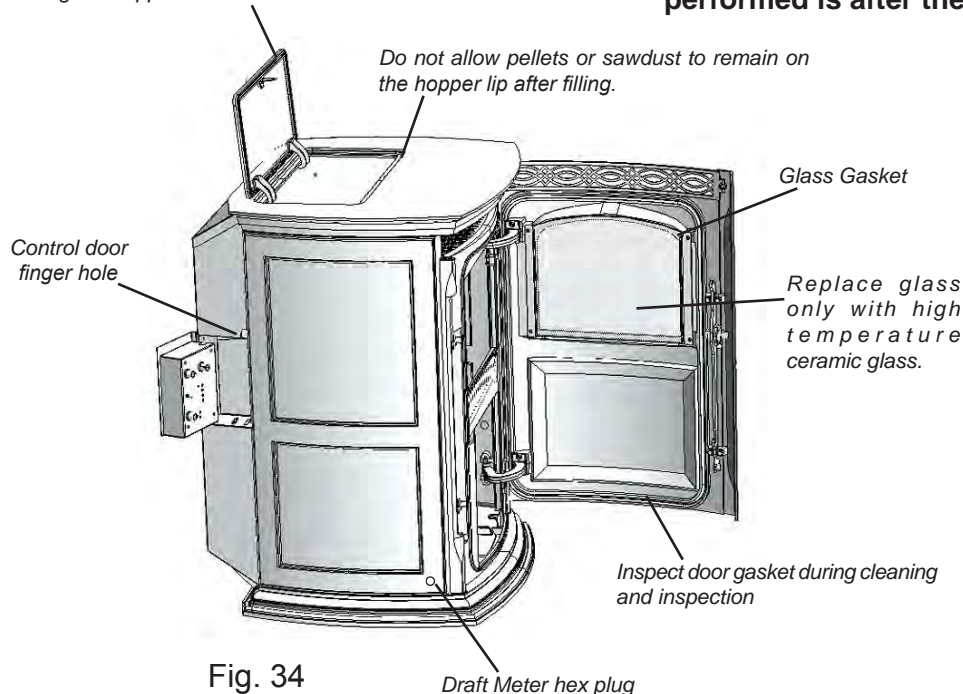

Fig. 34

Draft Meter hex plug

### Ash Removal

Due to potential high temperatures, it is recommended that the stove be out and cool prior to removing the ash pan. Open the front door and grasp the ash pan by the handle. With the ash pan removed, swing the handle upward for carrying.

**Disposal of Ashes-** Ashes should be placed in a metal container with a tight fitting lid. The closed container of ashes should be placed on a non-combustible floor or on the ground, well away from all combustible materials, pending final disposal. If the ashes are disposed of by burial in soil or otherwise locally dispersed, they should be retained in the closed container until all cinders have been thoroughly cooled.

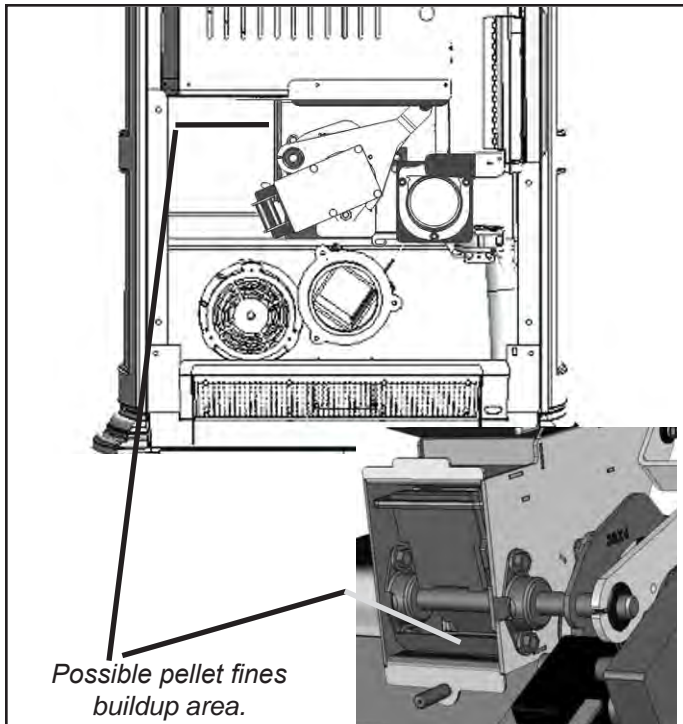

Possible pellet fines buildup area.

### Feeder Chamber

This chamber may get a buildup of fines from the feeder mechanism movement. This area should be checked and cleaned at least **once a year**.

#### To remove the feeder cover:

- Remove the (2) 5/16" wing nuts.
- Slide the cover off of the threaded studs.
- Inspect and clean the inner chamber if necessary. See above picture.
- Reinstall the cover making certain it is centered on the feeder body and tighten the wing nuts as tightly as you can by hand.

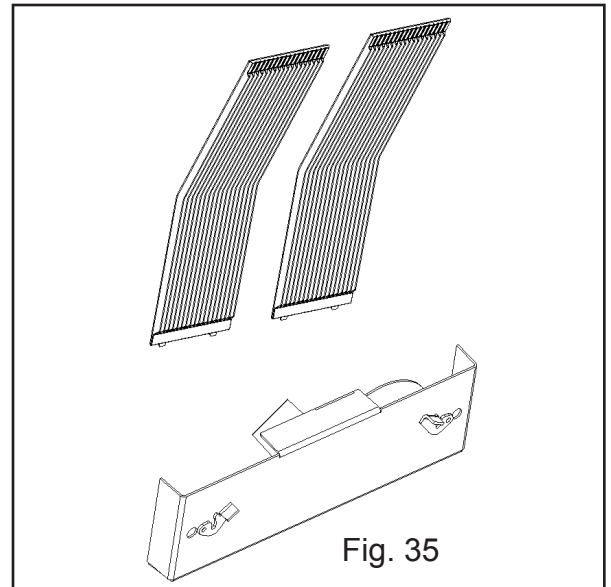

Fig. 35

### Cleaning Internal Components

**Recommended once per month or after each ton of pellets burned:**

1. Remove the two heat exchanger covers. See Fig. 35. These covers are made of cast iron and are held into place with a swing latch in the upper right and left corners. See Fig 36. Swing the latch upward far enough to release the top edge of the heat exchanger cover. Tilt the cover forward approximately 2" and lift it upward about 1" to release the bottom edge. The cover can now be taken completely out through the upper door opening. Repeat the process with the second heat exchanger cover.

*(Continued next page;)*

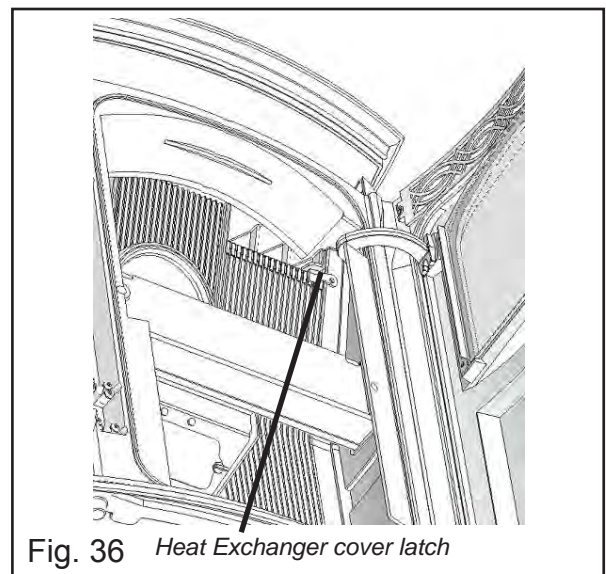
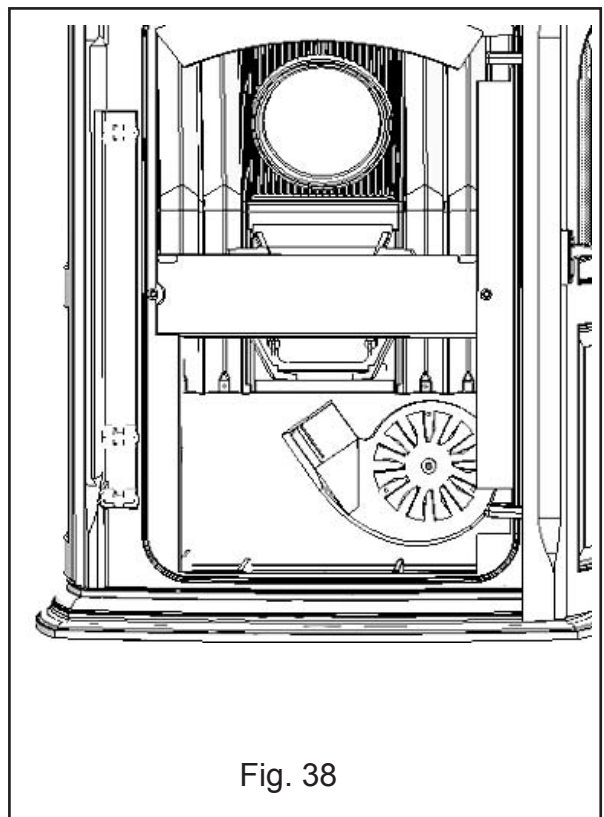
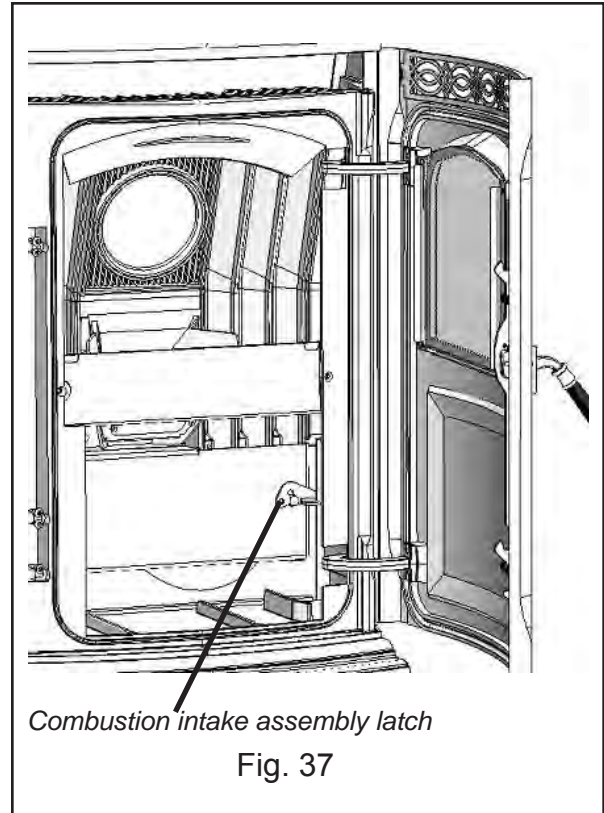

Fig. 36 Heat Exchanger cover latch

2. Remove the combustion intake assembly. See Fig. 35. The combustion intake assembly is held into place with two swing latches. See Fig. 37. Swing each latch until it hangs down away from the retainer stud. Now the assembly can be taken out by tilting the right side outward first through the lower door opening.

3. The units interior is now ready to clean. Use the scraper provided to clean the heat exchanger surfaces. A wire brush or short bristled brush is an excellent cleaning tool. Clean the fan blade and combustion blower fan housing. NOTE: Be careful not to bend the fan blade while cleaning. A bent blade will throw the fan blade out of balance. See Fig. 38.

4. With the blower housing open, there is easy access to the flue pipe exiting the rear of the unit. See Fig. 38. Vacuum the flue pipe as far into the pipe as possible. NOTE: Be careful while cleaning the flue pipe not to bend the exhaust probe. The ESP is approximately 8" into the tube and is visible when looking into the exhaust.





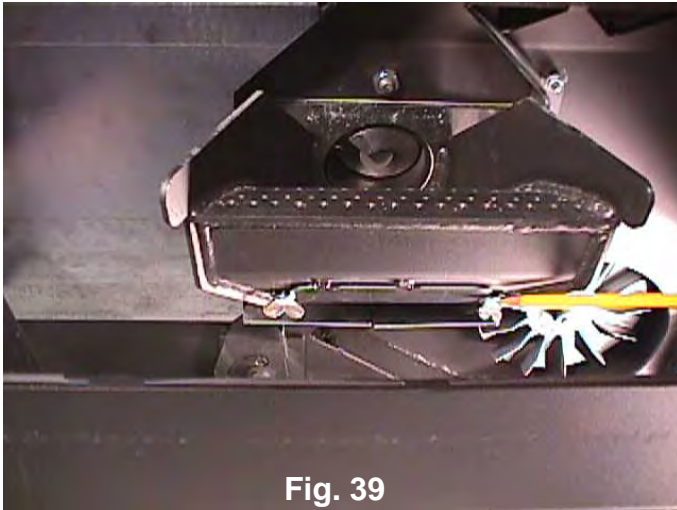

Fig. 39

### **Burn Pot Cleaning and Maintenance**

Whenever loading fuel into the hopper, take the opportunity to scrape the top holed surface and sides of the burn pot down to auger tube.(Fig 39) It is not necessary to completely remove all material from the burn pot. The excess will be pushed out during the next use.

Approximately once per month, clean out the air-flow portion of the burn pot: 1. Loosen the (2) wing thumb screws on the lower front angle of the burn pot. (Fig. 40)

2. Lift off the clean-out cover (Fig.40) to open the bottom clean-out chamber. (Fig.41)

3. Clean ash buildup from inside the chamber while cover is off. Use the scraper to tap on the top front edge of the burn pot. This will help knock pieces of ash, loosened by the scraping process, down through the holes. It also helps knock scale off of the igniter element.

### **Figure 41**

The igniter is made to be removable for service by insulated male/female wire connectors. These connections between the hot leads (the wires inside the burn pot) and the cold leads (the wires from the control board) are always pulled to the inside rear of the feeder body. **(Not coiled inside the burn pot.)**

It is very important that these connections are to the inside rear of the feeder body. Also, the extra wire of the igniter wire service loop must be pulled out through the rear of the feeder and tied up so that it will not be damaged by any moving parts.

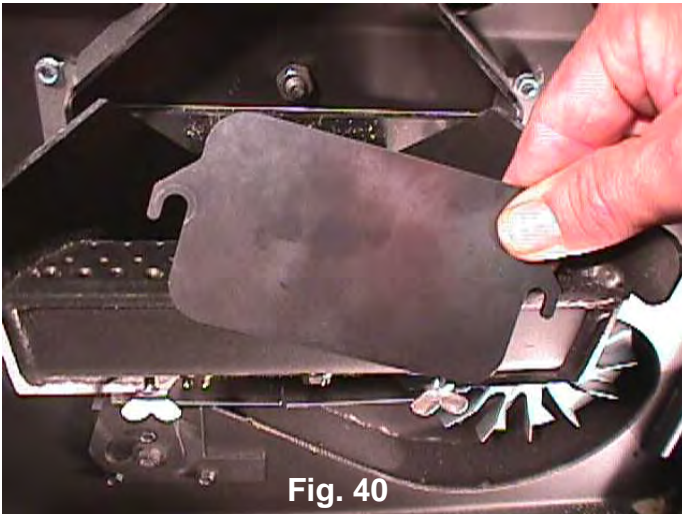

Fig. 40

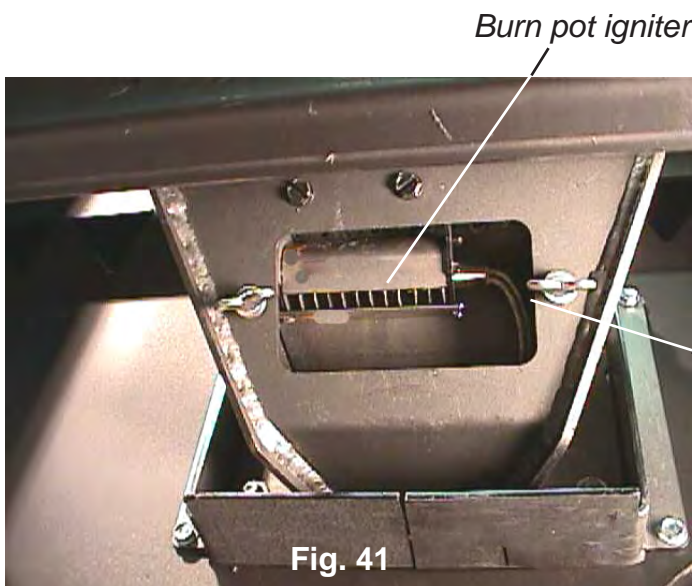

Fig. 41

Viewed from below through the ash pan opening.

### **WARNING**

**Use caution when cleaning burn pot clean-out chamber. Do not damage the high temperature igniter wires.**

*Igniter hot lead wires  
(High temperature)*

*Note: The hot lead/cold lead connection must always be pulled to the rear of the feeder body before operation.*



## Accentra Motor & Component Locations

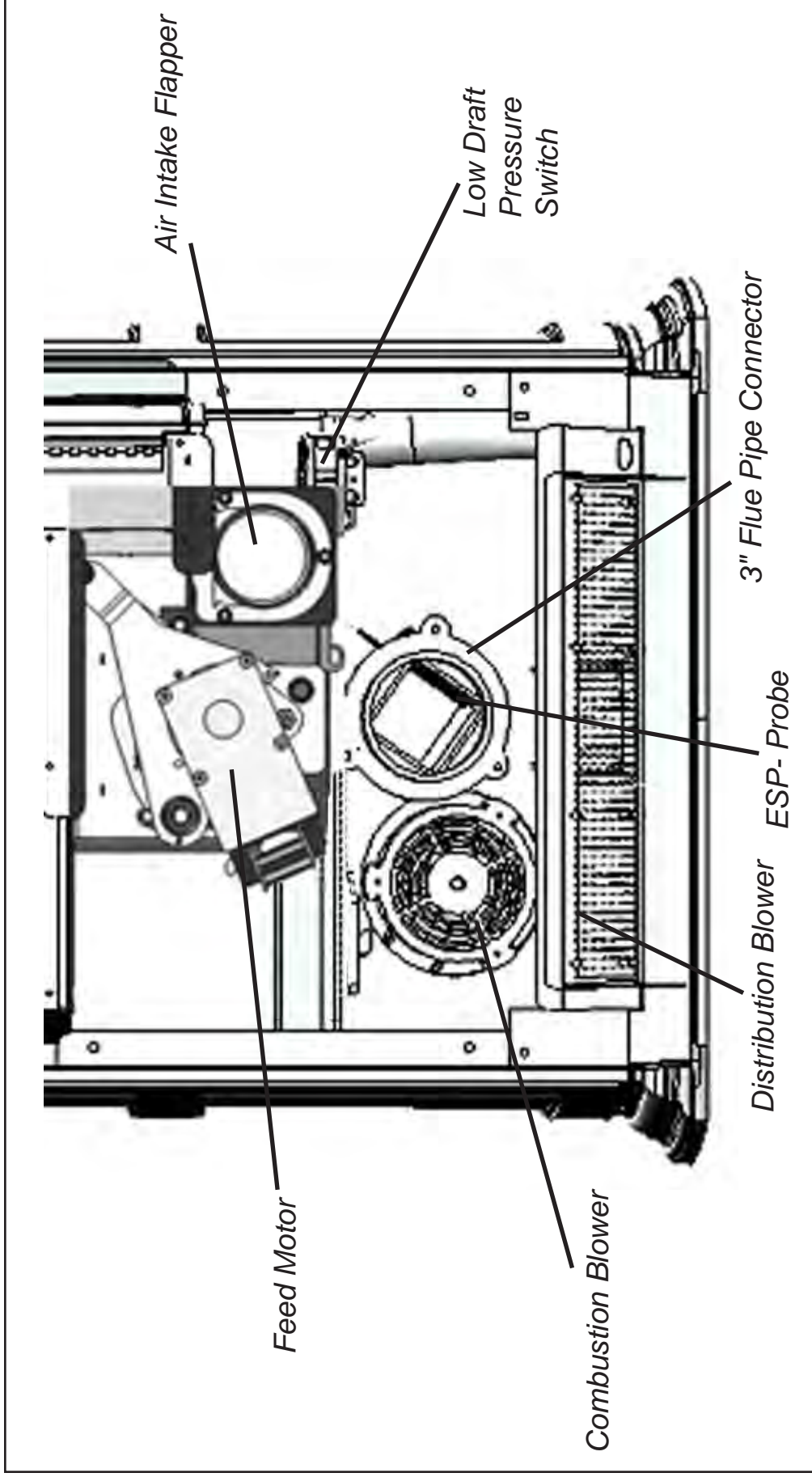

## Accentra Pellet Stove Safety Devices

The **Control Board/ESP** combination is responsible for all high limit safety control. There are 2 high limits, one normal operation high limit and one backup high limit. The control has an automatic diagnostic circuit that continuously monitors the ESP and Room Sensor for faults. If a fault should occur, the control sends a status alert and at the same time the unit goes down to minimum feed/minimum burn as a safety condition.

The **Low Draft Pressure Switch** is a differential pressure switch that senses the pressure between the firebox and the room. If the negative pressure in the firebox becomes too low for proper combustion, the switch opens, interrupting power to the feed motor and the igniter. If the switch "opens" during a rest period, the control will not try to feed or ignite. If the circuit opens during a feed or ignition cycle, the indicator lights will remain "on".

The **Hopper Lid Position Switch** is a plunger style switch located in the hopper lid opening. When the hopper lid is closed properly, it closes the switch. If the hopper lid is not fully closed, the switch opens, intercepting power to the feed motor and igniter. If the switch "opens" during a rest period, the control will not try to feed or ignite. If the circuit opens during a feed or ignition cycle, the indicator lights will remain "on".

## STOVE DOES NOT FEED

1. No fuel in hopper.
2. Firebox draft may be too low for sensing switch in feeder circuit to operate. **Check for closed doors**, loose or missing gasket on doors or hopper lid.
3. Hopper lid must contact the lid position switch.
4. Feed motor will not run until the ESP control senses a certain temperature. Maybe you did not put enough fuel or starting gel in the burn pot before manually lighting the fire.
5. Restriction in the hopper or feeder. Remove all fuel and examine. Clear the obstruction.
6. Feed motor has failed.

## PARTIALLY BURNED PELLETS

1. Feed rate too high.
2. Poor air to fuel mixture. (Check burn pot clean-out cover and air intake).
3. Burn pot or heat exchanger tubes may need to be cleaned.
4. Combination of all the above.
5. **#6 status blink:** A 6 blink control board status indication is caused by poor or incomplete combustion. The circuit board has the ability to track the combustion through feed settings and ESP temperatures. When the control board has calculated poor or incomplete combustion, it will shut down the unit as a safety feature. (Poor or incomplete combustion is a contributor of creosote which may cause a chimney fire)

A 6 blink status may be caused by several things:

1. Blocked or partially blocked flue.
2. Blocked or partially blocked inlet air.
  - a. Backdraft damper on the inlet pipe may be stuck closed.
  - b. If outside air is installed, the inlet cover may be blocked.
3. The air chamber under the burnpot may be filled with fines and small bits of ash.
4. The holes in the burnpot may be getting filled with ash or carbon buildup.
5. Combustion blower fan blades may need cleaned.
6. Fuel restrictions as noted above.

## SMOKE SMELL

Seal the vent pipe joints and connection to stove with high-temperature silicone.

## FIRE HAS GONE OUT - Check for "Status" code.

1. No pellets in hopper.
2. Draft setting is too low.
3. Something is restricting fuel flow.
4. Feed motor or draft motor has failed.
5. Power failure or blown fuse.

## SMOKE IS VISIBLE COMING OUT OF VENT

1. Air-fuel ratio is too rich.
  - A. Feed rate too high.
  - B. Draft too low caused by a gasket leak.

## LOW HEAT OUTPUT

1. Feed rate too low
2. Draft too low because of gasket leak.
3. Poor quality or damp pellets
4. Combination of 1. and 2.

## Helpful Hints

### Cleaning Burn Pot

Whenever your stove is not burning, take the opportunity to scrape the burn pot to remove carbon buildup. A vacuum cleaner is handy to remove the residue. Be sure the stove is cold if you use a vacuum.

Carbon buildup can be scraped loose with the fire burning using the special tool provided with your stove. Scrape the floor and sides of the burn pot. The carbon will be pushed out by the incoming fuel. Always wear gloves to do this.

### Removing Ashes

Turn the Temp Dial to number 1 approximately 30 minutes before removing ashes. This will result in a cooler stove and ash pan.

Maximum Feed Adjuster settings are not needed in most cases. Operating in the normal range (#4) is recommended when maximum heat output is not required. The ESP prevents the stove from being over-fired.

Keep the stove free of dust and dirt.

## Fuel

Pellet fuels are put into 3 categories in terms of ash content. Premium at 1% or less, Standard at 3% or less and all others at 3% or more.

The Accentra is capable of burning all 3 categories of pellets, or up to a 50% corn and pellet mixture, due to a patented feeder and burn pot system.

It should be noted, however, that higher ash content pellets, and a corn mixture will require more frequent ash removal and may provide less BTU's per pound.

The moisture content of pellet fuel must not exceed 8%, corn should be 15% or less. Higher moisture will rob BTU's and may not burn properly.

Keep fuel in a dry location. Do not store fuel within the installation clearance area of the room heater.

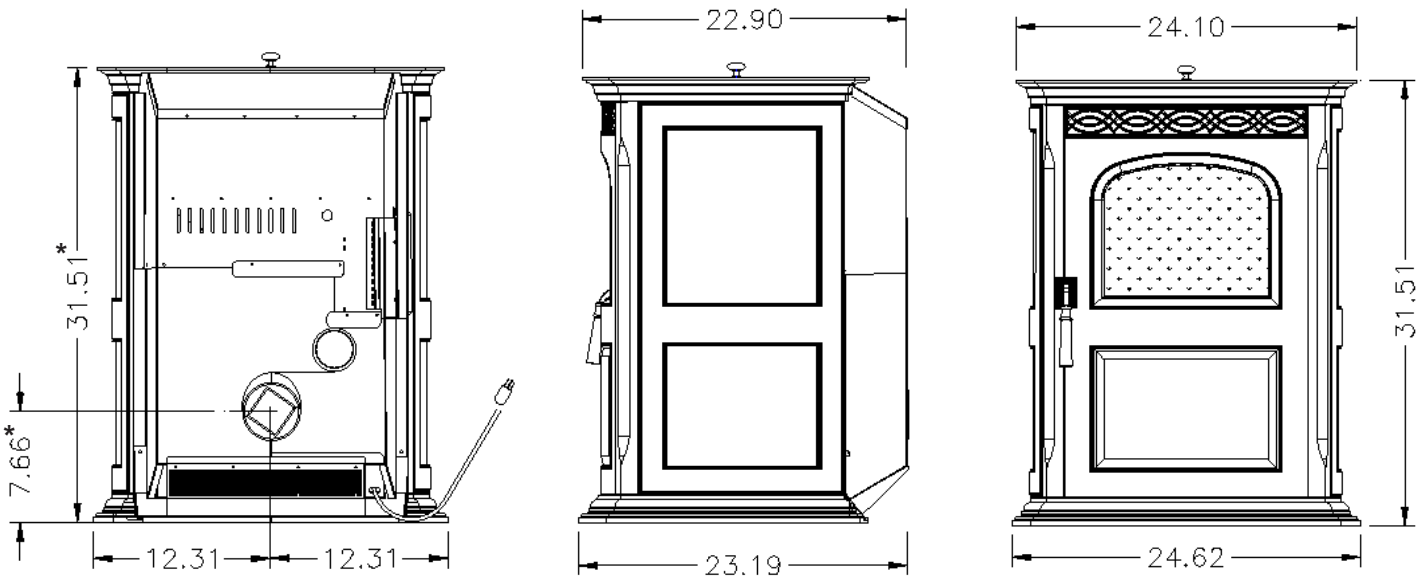

**\* Note: Installation of the optional leg kit adds 2.95 inches of height.**

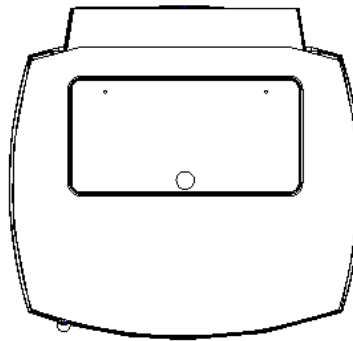

<b>Weight</b>	<b>400 lbs.</b>
<b>Blower</b>	<b>150 cfm</b>
<b>Hopper Capacity</b>	<b>50 lbs.</b>
<b>Fuel</b>	<b>Wood Pellets, Corn/Pellet Mixture</b>
<b>Outside Air Size</b>	<b>2 3/8 inches</b>
<b>Fuse Rating</b>	<b>5 amp</b>
<b>BTU Range</b>	<b>0 to 40,000</b>
<b>Feed Rate</b>	<b>.75 lbs./hr. on minimum (on maintenance)</b> <b>5 lbs./hr. on maximum</b>
<b>Flue Size</b>	<b>3 inch Pellet Vent Pipe</b>
<b>Maximum Wattage</b>	<b>440 Watts (Start cycle and test)</b>
<b>Start Cycle Wattage</b>	<b>340 Watts</b>
<b>Normal Run Wattage</b>	<b>255 Watts</b>

# Accentra Wiring Diagram

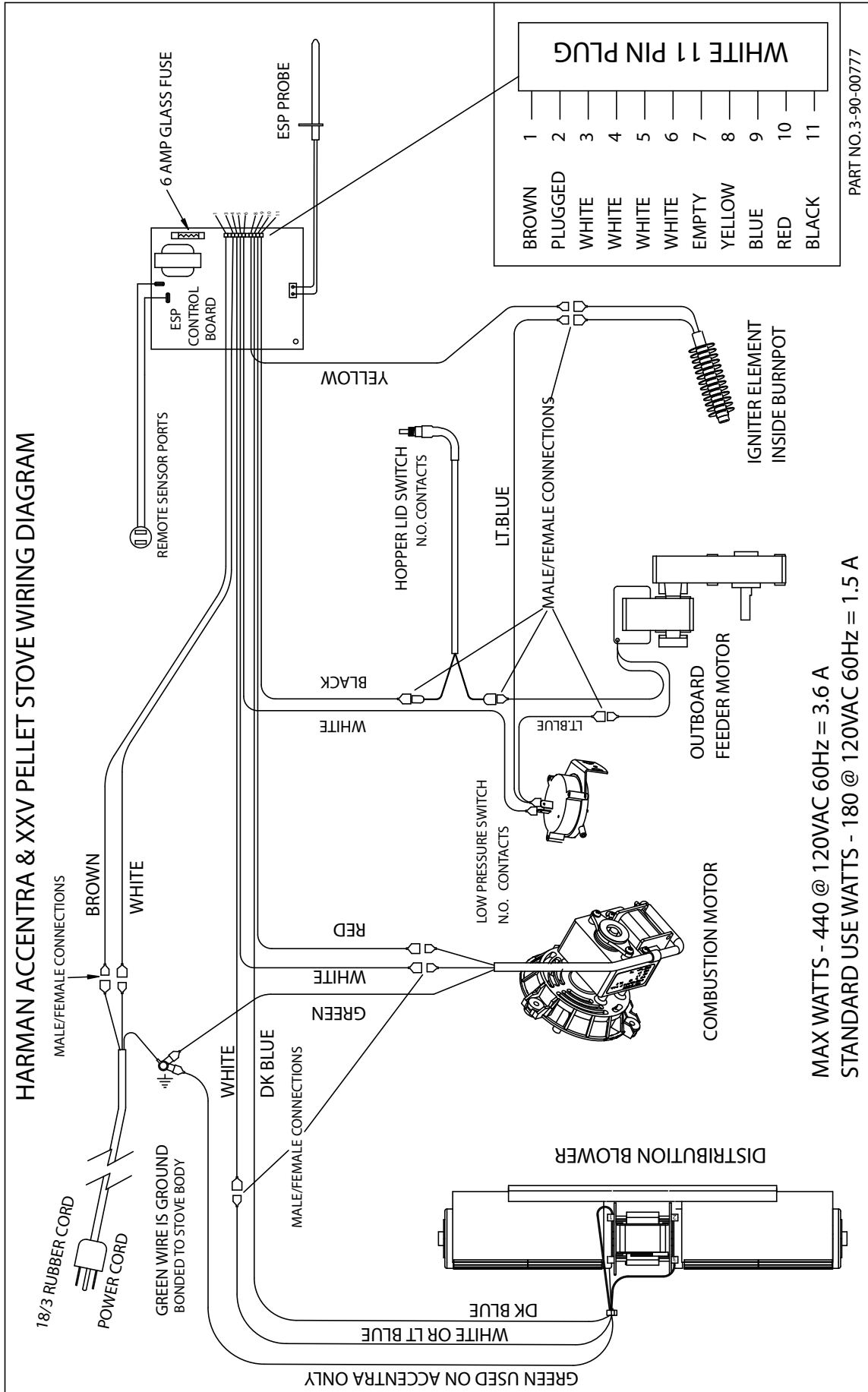



## Addendum for Burning Corn and Pellet Fuel Mixture

Harman pellet burning, free-standing stoves and inserts have been tested to ASTM E1509 for burning shelled corn in a mixture with wood pellets. The listing approves up to a 50% corn and 50% pellet mixture. Different mixtures of corn will have distinctively different burn characteristics depending upon moisture content and variety. The operator should closely monitor the stove's operation when burning a new corn/pellet mixture or a different variety of corn, and make any necessary adjustments to feed rate. Since corn is typically higher in ash and moisture content, cleaning and ash removal will be needed more frequently.

### Operation in Stove Temp mode

Set feed adjuster to # 3. Set temperature knob to #3, Turn mode selector knob onto "Stove Temp" mode. After the fire has lit, watch that the fuel does not feed too fast that it pushes the red glowing fuel bed off of the burn pot grate. If it does, lower the feed adjuster setting or use a lower percentage of corn in the mixture. After the stove has burned for 10 minutes and the entire fuel bed is burning, the feed adjuster and temperature knobs may be adjusted for higher heat output if desired. Maximum feed has been reached when the fire bed is about ½ to 1 inch from the end of the burn pot. Settings will vary with different types, moisture levels and mix ratios of corn. If you are having difficulty burning a 50% corn / 50% wood pellet mixture, try a lower percentage of corn.

### Operation in Room Temp mode

Set feed adjuster to # 2 or # 3. Set temperature knob to desired amount. Turn mode selector knob onto "Room Temp" mode. After the fire has lit, watch that the fuel does not feed too fast that it pushes the red glowing fuel bed off of the burn pot grate. After the stove has burned for 10 minutes and the entire fuel bed is burning, the feed adjuster may be set to a higher output level if desired. Maximum feed has been reached when the fire bed is about ½ to 1 inch from the end of the burn pot. It is recommended that after burning at the desired settings, turn the stove off and allow it to cool, then turn it back on in "Room Temp" mode and watch the stove restart and verify correct operation. Settings will vary with different types, moisture levels and mix ratios of corn. If you are having difficulty burning a 50% corn 50% wood pellet mixture, try a lower percentage of corn.

### Changes to Maintenance Schedule

Wood pellets average around 6% moisture content or less. Corn will be 14 or 15% moisture. With more moisture in the fuel, more maintenance will be incurred. Burn pot scraping may need to be done once per day. The ash pan will fill more quickly and may need emptied weekly. Most importantly, remove the burn pot cleanout cover weekly to clean the air passage and the igniter element. Excessive buildup on the igniter may lead to shortened igniter life.

**Venting Consideration:** Check with your venting manufacturer regarding possible exclusions when a mixture of corn and pellets is burned.

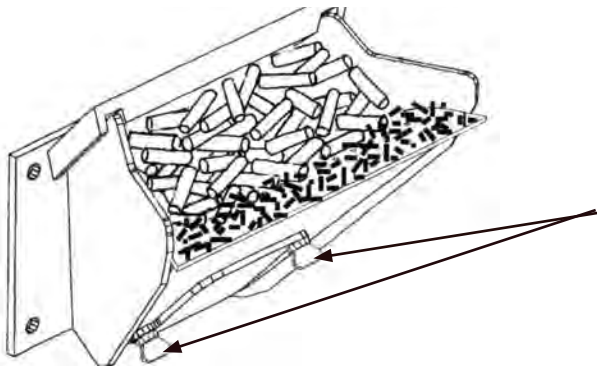

Loosen these two wing screws for access to clean the air passage and igniter.

## Hearth & Home Technologies Inc. LIMITED LIFETIME WARRANTY

Hearth & Home Technologies Inc., on behalf of its hearth brands ("HHT"), extends the following warranty for HHT gas, wood, pellet, coal and electric hearth appliances that are purchased from an HHT authorized dealer.

### **WARRANTY COVERAGE:**

HHT warrants to the original owner of the HHT appliance at the site of installation, and to any transferee taking ownership of the appliance at the site of installation within two years following the date of original purchase, that the HHT appliance will be free from defects in materials and workmanship at the time of manufacture. After installation, if covered components manufactured by HHT are found to be defective in materials or workmanship during the applicable warranty period, HHT will, at its option, repair or replace the covered components. HHT, at its own discretion, may fully discharge all of its obligations under such warranties by replacing the product itself or refunding the verified purchase price of the product itself. The maximum amount recoverable under this warranty is limited to the purchase price of the product. This warranty is subject to conditions, exclusions and limitations as described below.

### **WARRANTY PERIOD:**

Warranty coverage begins on the date of installation. In the case of new home construction, warranty coverage begins on the date of first occupancy of the dwelling or six months after the sale of the product by an independent, authorized HHT dealer/ distributor, whichever occurs earlier. The warranty shall commence no later than 24 months following the date of product shipment from HHT, regardless of the installation or occupancy date. The warranty period for parts and labor for covered components is produced in the following table.

The term "Limited Lifetime" in the table below is defined as: 20 years from the beginning date of warranty coverage for gas appliances, and 10 years from the beginning date of warranty coverage for wood, pellet, and coal appliances. These time periods reflect the minimum expected useful lives of the designated components under normal operating conditions.

Warranty Period		HHT Manufactured Appliances and Venting							Components Covered
Parts	Labor	Gas	Wood	Pellet	EPA Wood	Coal	Electric	Venting	
1 Year		X	X	X	X	X	X	X	All parts and material except as covered by Conditions, Exclusions, and Limitations listed
2 years				X	X	X			Igniters, electronic components, and glass
		X	X	X	X	X			Factory-installed blowers
				X					Molded refractory panels
3 years				X					Firepots and burnpots
5 years	1 year			X	X				Castings and baffles
7 years	3 years		X	X	X				Manifold tubes, HHT chimney and termination
10 years	1 year	X							Burners, logs and refractory
Limited Lifetime	3 years	X	X	X	X	X			Firebox and heat exchanger
90 Days		X	X	X	X	X	X	X	All replacement parts beyond warranty period

See conditions, exclusions, and limitations on next page.

## **WARRANTY CONDITIONS:**

- This warranty only covers HHT appliances that are purchased through an HHT authorized dealer or distributor. A list of HHT authorized dealers is available on the HHT branded websites.
- This warranty is only valid while the HHT appliance remains at the site of original installation.
- Contact your installing dealer for warranty service. If the installing dealer is unable to provide necessary parts, contact the nearest HHT authorized dealer or supplier. Additional service fees may apply if you are seeking warranty service from a dealer other than the dealer from whom you originally purchased the product.
- Check with your dealer in advance for any costs to you when arranging a warranty call. Travel and shipping charges for parts are not covered by this warranty.

## **WARRANTY EXCLUSIONS:**

This warranty does not cover the following:

- Changes in surface finishes as a result of normal use. As a heating appliance, some changes in color of interior and exterior surface finishes may occur. This is not a flaw and is not covered under warranty.
- Damage to printed, plated, or enameled surfaces caused by fingerprints, accidents, misuse, scratches, melted items, or other external sources and residues left on the plated surfaces from the use of abrasive cleaners or polishes.
- Repair or replacement of parts that are subject to normal wear and tear during the warranty period. These parts include: paint, wood, pellet and coal gaskets; firebricks; grates; flame guides; and the discoloration of glass.
- Minor expansion, contraction, or movement of certain parts causing noise. These conditions are normal and complaints related to this noise are not covered by this warranty.
- Damages resulting from: (1) failure to install, operate, or maintain the appliance in accordance with the installation instructions, operating instructions, and listing agent identification label furnished with the appliance; (2) failure to install the appliance in accordance with local building codes; (3) shipping or improper handling; (4) improper operation, abuse, misuse, continued operation with damaged, corroded or failed components, accident, or improperly/incorrectly performed repairs; (5) environmental conditions, inadequate ventilation, negative pressure, or drafting caused by tightly sealed constructions, insufficient make-up air supply, or handling devices such as exhaust fans or forced air furnaces or other such causes; (6) use of fuels other than those specified in the operating instructions; (7) installation or use of components not supplied with the appliance or any other components not expressly authorized and approved by HHT; (8) modification of the appliance not expressly authorized and approved by HHT in writing; and/or (9) interruptions or fluctuations of electrical power supply to the appliance.
- Non-HHT venting components, hearth components or other accessories used in conjunction with the appliance.
- Any part of a pre-existing fireplace system in which an insert or a decorative gas appliance is installed.
- HHT's obligation under this warranty does not extend to the appliance's capability to heat the desired space. Information is provided to assist the consumer and the dealer in selecting the proper appliance for the application. Consideration must be given to appliance location and configuration, environmental conditions, insulation and air tightness of the structure.

### **This warranty is void if:**

- The appliance has been over-fired or operated in atmospheres contaminated by chlorine, fluorine, or other damaging chemicals. Over-firing can be identified by, but not limited to, warped plates or tubes, rust colored cast iron, bubbling, cracking and discoloration of steel or enamel finishes.
- The appliance is subjected to prolonged periods of dampness or condensation.
- There is any damage to the appliance or other components due to water or weather damage which is the result of, but not limited to, improper chimney or venting installation.

## **LIMITATIONS OF LIABILITY:**

- The owner's exclusive remedy and HHT's sole obligation under this warranty, under any other warranty, express or implied, or in contract, tort or otherwise, shall be limited to replacement, repair, or refund, as specified above. In no event will HHT be liable for any incidental or consequential damages caused by defects in the appliance. Some states do not allow exclusions or limitation of incidental or consequential damages, so these limitations may not apply to you. This warranty gives you specific rights; you may also have other rights, which vary from state to state. EXCEPT TO THE EXTENT PROVIDED BY LAW, HHT MAKES NO EXPRESS WARRANTIES OTHER THAN THE WARRANTY SPECIFIED HEREIN. THE DURATION OF ANY IMPLIED WARRANTY IS LIMITED TO DURATION OF THE EXPRESSED WARRANTY SPECIFIED ABOVE.

1-90-02470-1 (Black), 1-90-02470-2 (Charcoal), 1-90-02470-3 (Goldenfire), 1-90-02470-4 (Metallic Blue),  
1-90-02470-5 (Honey Glo), 1-90-02470-10 (Mojave Red), 1-90-02470-12 (Forest Green), 1-90-02470-13 (Black Enamel),  
1-90-02470-14 (Majolica Brown Enamel), 1-90-02470-15 (Sand Enamel)

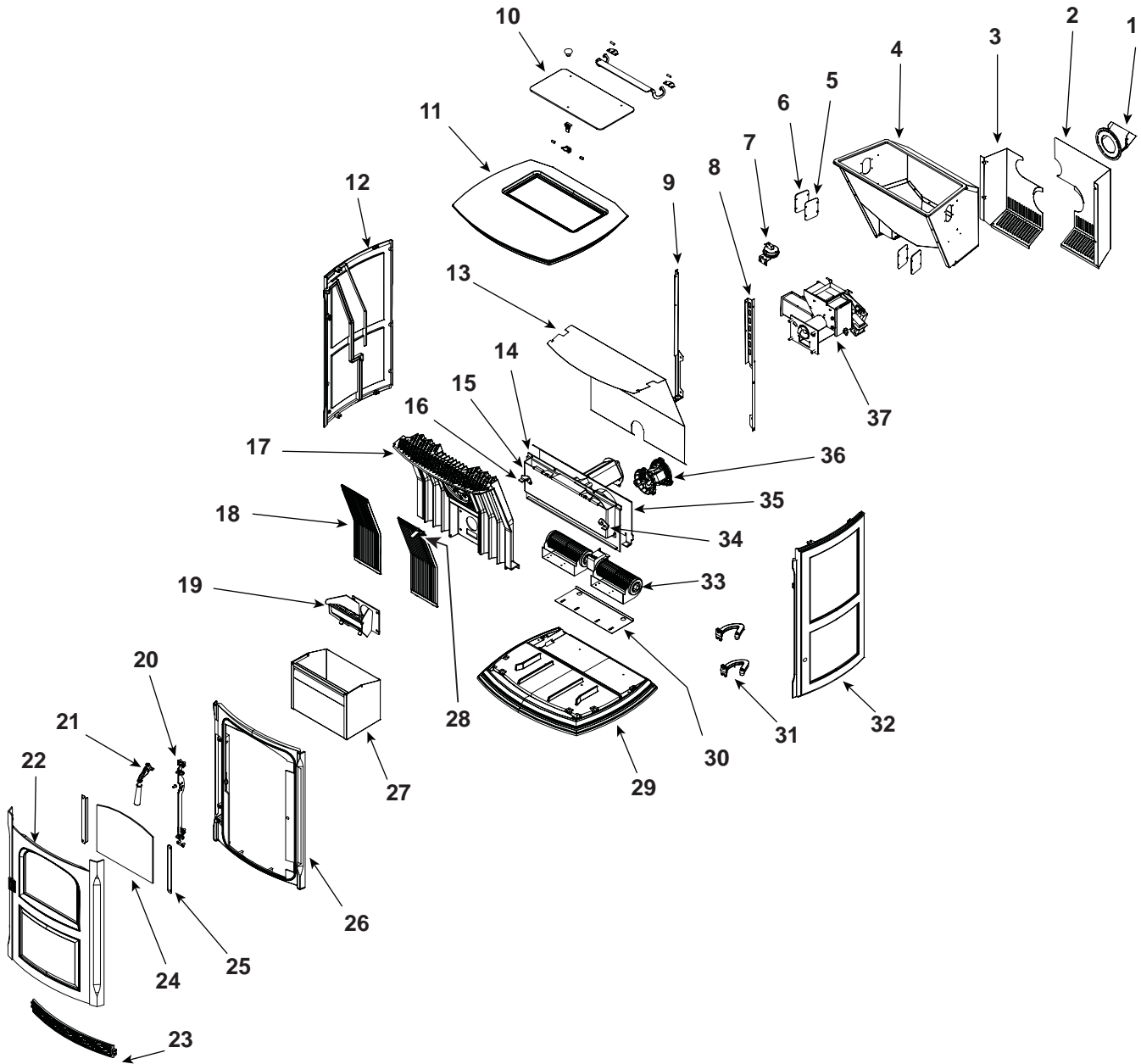

Part number list on following page.



IMPORTANT: THIS IS DATED INFORMATION. When requesting service or replacement parts for your appliance please provide model number and serial number. All parts listed in this manual may be ordered from an authorized dealer.



**Stocked  
at  
Harman  
MFG**

ITEM	Description	COMMENTS	PART NUMBER	Stocked at Harman MFG
1	Flue Tail Pipe		3-00-247237	Y
2	Feeder Shield Right	Pre 008402885	1-10-247142P	Y
		Post 008402885	1-10-247554	Y
3	Feeder Shield Left	Pre 008402885	1-10-247141P	Y
		Post 008402885	1-10-247553	Y
4	Hopper Assembly	Pre 008400001	1-10-247213A	Y
		008400001 Thru 008403501	1-10-247244A	Y
		Post 008403501	1-10-247778A	
	Hopper Switch 48"	Post 008403501	3-20-232108	Y
5	Top Bolt Down Cover	Qty. 2 Req.	2-00-247185L	
6	Top Bolt Down Cover Gasket	Qty. 2 Req.	3-44-247600	
7	Differential Switch		3-20-6866	Y
8	Z Bracket, Right		2-00-247119B	
9	Z Bracket, Left		2-00-247139B	
10	Glass Hopper Lid		3-40-247100	Y
11	Cast Top		4-00-247236S	
12	Cast Side Plate Left		4-00-247106D	
13	Air Jacket Top		2-00-247219B	
14	Cast Combustion Housing		4-00-247104D	
15	Comb Intake Assembly		1-10-247124W	Y
16	Comb Manifold Latch Left		2-00-247126-1S	
17	Cast Heat Exchanger		4-00-247103D	
18	Cast Accordion Cover	Qty. 2 Req.	3-00-247105	Y
19	Burn Pot Assembly		1-10-08736	Y
	Ignitor		3-20-677200	Y
	Ignitor Cradle		2-00-06620B	
	Ignitor Holder		2-00-06621B	
	Ignitor Flat Bottom		2-00-06633L	
	Flame Guide		3-00-08534	Y
20	Door Latch Assembly			
	Latch Bar		2-00-247175L	
	Dowel Pin Retainer		2-00-247187L	
	5/16" Shldr x 1/4" x 1/4"-20 Thrd Alloy Steel Shoulder Screw	Pkg of 5	3-30-1105-5	
	5/16" x 3/4" 18-8 Stainless Steel Flat Washer	Pkg of 100	3-30-9003-100	
	Dowel Pin 1/4" x 1-1/4"		3-31-025125	

Additional service parts on following page.



IMPORTANT: THIS IS DATED INFORMATION. When requesting service or replacement parts for your appliance please provide model number and serial number. All parts listed in this manual may be ordered from an authorized dealer.



**Stocked at Harman MFG**

ITEM	Description	COMMENTS	PART NUMBER	Stocked at Harman MFG
	Arrow Burn Pot Scraper		2-00-773850	
	1/4"-20 x 1/4" Alloy Steel Black Oxide Button Head Cap Screw	Pkg of 50	3-30-3013-50	
	1/4"-20 x 3/8" Alloy Steel Black Oxide Button Head Cap Screw	Pkg of 100	3-30-3014-100	
	Burn Pot Gasket	Qty. 2 Req.	3-44-00409	Y
	Brushed Nickel Knob		3-43-02000-8	
	Circuit Board		1-00-05886	Y
	Control Board Knob/D-Shaft	Qty. 3 Req.	3-31-605	Y
	Control Board Plate Assembly		1-10-247157S	
	Dee Shaped Control Knob Shaft	Qty. 3 Req.	3-31-015	Y
	Distribution Blower Gasket		3-44-247118	
	Distribution Blower Screen Frame	Pre 008402885	2-00-247173B	
	Door Handle - Gold Plated		3-00-247112-4	
	Fuse 6 AMP		3-20-49447	Y
	Gasket,Glass Hopper Lid	Pre 11340	3-44-247300	
		Post 11340	1-00-375501	
	Gold Plated Knob (Hopper)		3-43-02000	
	Hopper Ball Spring Plunger (Threaded)		3-31-5500	
	Hopper Lid Ball Spring Mount Bracket	Pre 11340	2-00-247116	
	Hopper Lid Glass Assembly w/Gasket	Pre 11340	1-10-247100	Y
	Hopper Lid Hinge		2-00-06694	
	Hopper Lid Spring Latch	Pre 11340	2-00-247167	
	Inlet Reduction Ring (Combustion Blower)		1-00-247234	
	Nylon Washer 1/4" (Used with Screw Post - 4 per)		3-31-95606	
	Owners Manual		3-90-08326	
	Pellet Tailpipe Gasket		3-44-06179	Y
	Pillow Block - 1/2"		3-31-3614087	
	Power Cord - 8'		3-20-39685	
	Rocker Switch		3-20-07625	
	Room Sensor		3-20-00906	Y
	Screw Post 1/4" (Hopper Lid - 2 per)		3-31-129004	
	Thermister Probe Replacement w/Gel Caps	Pre 00840167	1-00-00744	Y
	Thermister Probe (ESP Probe)	Post 00840167	3-20-00844	Y
	Thermostat Extension		3-20-00607	
	Wiring Harness		3-20-08727	
	1/4"-20 x 2 1/2" Phillips Round Head Zinc Pltd Machine Screw	Pkg of 25	3-30-6007-25	

Additional service parts on following page.

### Pre Serial Number 00840001 Feeder Assembly

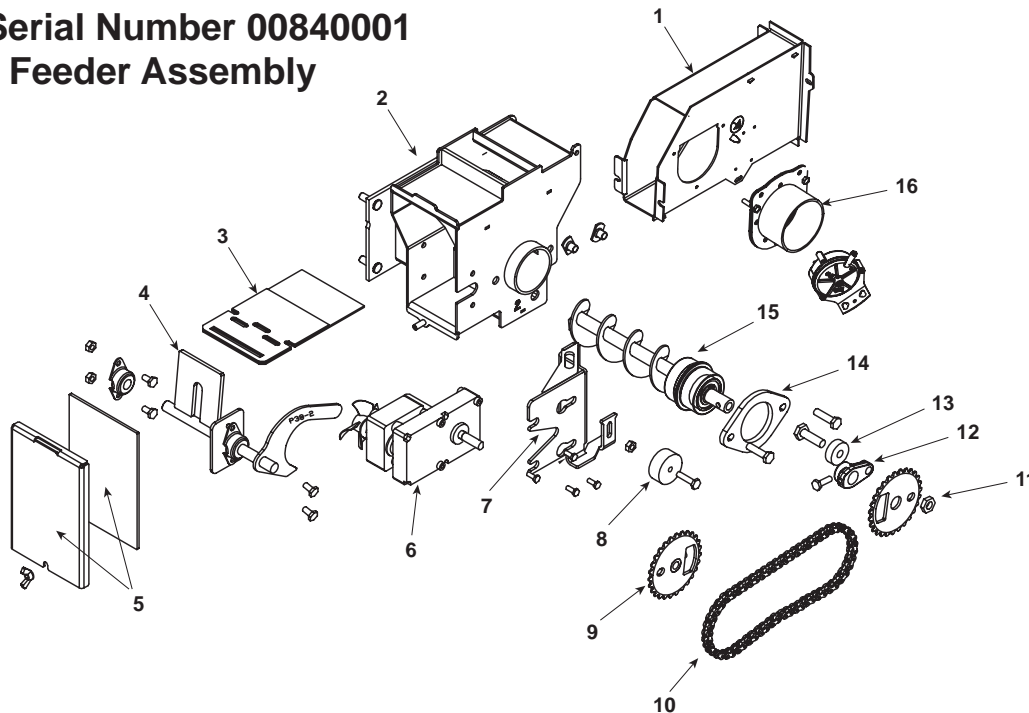

IMPORTANT: THIS IS DATED INFORMATION. When requesting service or replacement parts for your appliance please provide model number and serial number. All parts listed in this manual may be ordered from an authorized dealer.



Stocked  
at  
Harman  
MFG

ITEM	Description	COMMENTS	PART NUMBER	Stocked at Harman MFG
1	Air Intake Weldment		1-10-247221W	
2	Feeder Weldment		1-10-677150	
3	Slide Plate Assembly		1-10-08037	
4	Pusher Arm Assembly		1-10-247220	Y
5	Gasket, EPDM Feeder Cover		3-44-677153	Y
5	Feed Cover		2-00-677152B	Y
6	Gear Motor, 4 RPM		3-20-08752	Y
7	Bracket, Gear Motor		1-10-677005	Y
8	Tensioner		3-31-00075	Y
9	Small Sprocket W/ Hub		3-50-08762	Y
10	56 Pin Chain		3-50-06667	Y
11	Large Sprocket W/O Hub		3-50-06626	Y
12	Cast Cam Block		3-00-00153	
13	Cam Bearing		3-31-3014	Y
14	Bearing Flange		2-00-04035L	
15	Auger Assembly		3-50-00465	Y
16	Air Intake Damper Assembly		1-10-06810A	
	Feeder Repair kit		1-00-677150	Y

Additional service parts on following page.



### Post Serial Number 008400001 Feeder Assembly

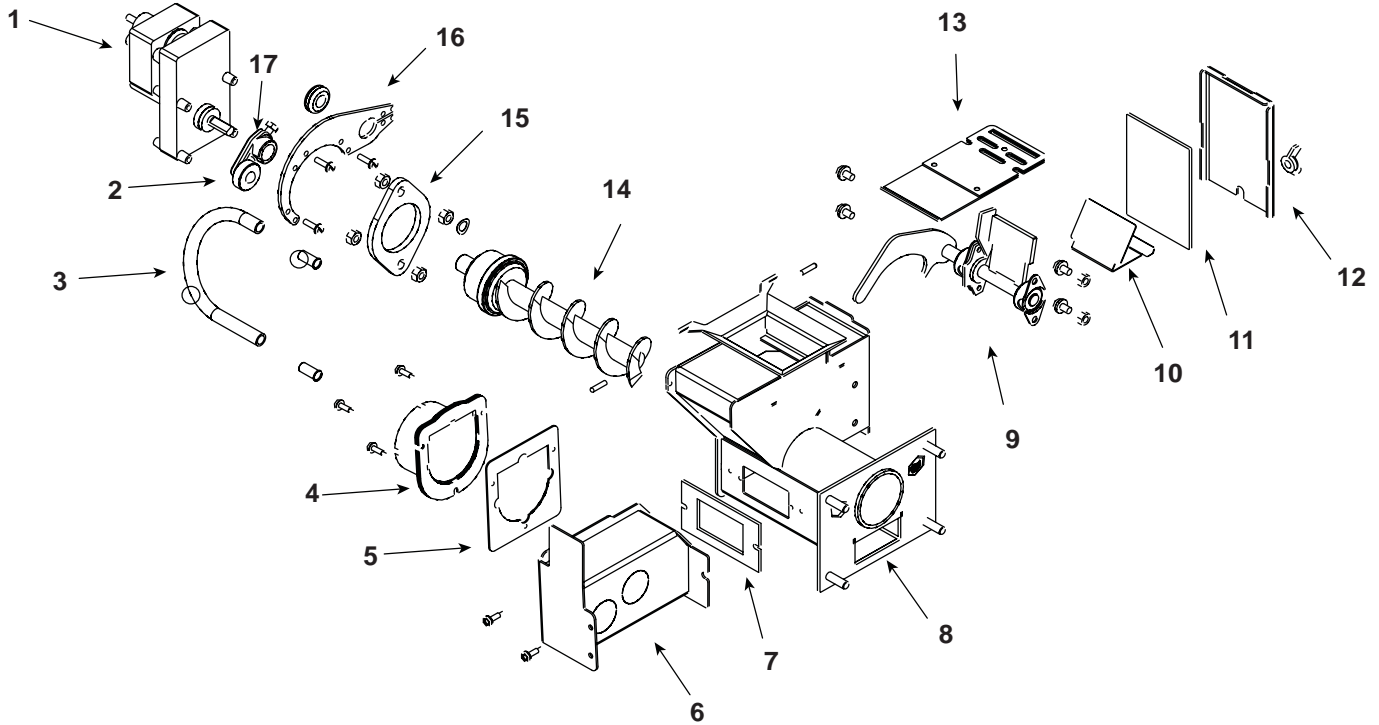

IMPORTANT: THIS IS DATED INFORMATION. When requesting service or replacement parts for your appliance please provide model number and serial number. All parts listed in this manual may be ordered from an authorized dealer.



Stocked  
at  
Harman  
MFG

ITEM	Description	COMMENTS	PART NUMBER	Stocked at Harman MFG
1	Pellet Feeder Gear Motor, 4 RPM		3-20-00677	Y
2	UL Feeder Cam Bearing		3-31-3014	Y
3	9MM Silicone Tube		1-00-511427	
4	Pellet Air Intake Assembly		1-10-06810A	
5	Gasket Feeder Air Intake		3-44-72224	
6	UL Feeder Air Intake		1-10-247239	
7	Gasket Ultra Air Intake		3-44-677160	
8	Ultra Feeder Weldment		1-10-724132	
9	UL Feeder Pusher Arm		1-10-677131W	Y
10	Fines Deflector		2-00-677138B	
11	Gasket, UL Feeder Cover		3-44-677155	Y
12	UL Feeder Cover Short		2-00-677122L	Y
13	Slide Plate Assembly		1-10-677121A	
14	UL Feeder Auger Assembly		3-50-00565	Y
15	Pellet Feeder Bearing Retainer		2-00-04035L	
16	UL Feeder Gear Motor Bracket		2-00-247406L	
17	UL Feeder Cam Block		3-00-677154	





