

# Riva HEAT ONLY

## WALL HUNG GAS BOILER FOR CENTRAL HEATING SUPPLY

**Please Read Instructions Carefully  
Save for Future Reference**

**WARNING:** If the information in this manual is not followed exactly, a fire or explosion may result causing property damage, personal injury or loss of life.

- Do not store or use gasoline or other flammable vapors and liquids in the vicinity of this or any other appliance.
- **WHAT TO DO IF YOU SMELL GAS**
  - Do not try to light any appliance.
  - Do not touch any electric switch; do not use any phone in your building.
  - Immediately call your gas supplier from a neighbor's phone. Follow the gas supplier's instructions.
  - If you can not reach your gas supplier call the fire department.
- Installation and service must be performed by a qualified installer, service agency or the gas supplier.

Manufactured by:

 **BIASI**  
Biasi S.p.A.  
Verona, Italy

Distributed By:

 **QHT**  
INCORPORATED  
Quincy Hydronic Technologies, Inc.  
80 Rochester AVE. Suite # 12  
Portsmouth, NH 03801  
Phone: 603-334-6400  
Fax: 603-334-6401



**1 The Technical Manual**

The aim of this manual is to provide technical assistance operators with all the information necessary to facilitate maintenance of Biasi products.

To use this manual in the best possible way and to find the information in it quickly it is necessary to understand how it is laid out by reading the following carefully:

**2 Manual layout**

The manual is divided into three different parts (fig. 1).

The first part contains the general instructions on how to use and consult the manual; the nomenclature of the models illustrated in this manual and the grouping criteria for each family.

The second part contains booklets with technical data, hydraulic and wiring diagrams, troubleshooting instructions and start-up checks, grouped into product families.

The third part contains the technical data sheets relative to each component, its basic characteristics, checking its condition and replacing and/or servicing.

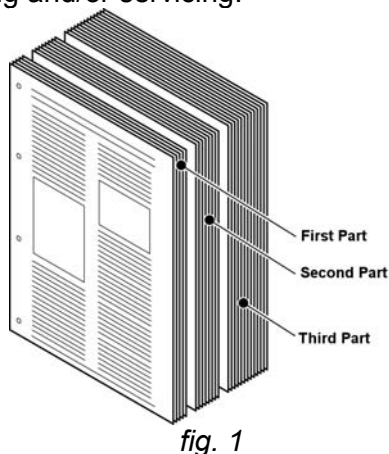

fig. 1

Parts two and three are preceded by an index that gives the contents and their order of arrangement.

**3 Topic, numbering, edition**

The topic dealt with on each card is also shown in the top right corner of each page, the part in the top left corner. The pages are numbered in the bottom corner (fig. 2).

Technical sheet edition date (month and year) is given between the Part and the Argument on top of the page.

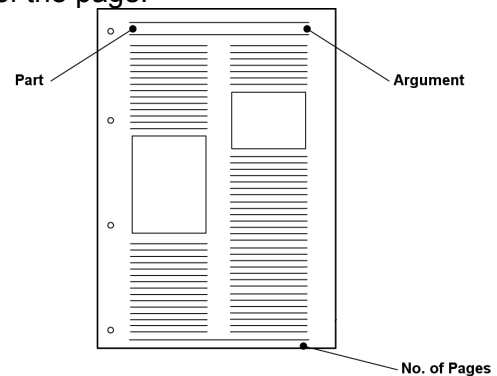

fig. 2

Part one is laid out with consecutive numbers (fig. 3).

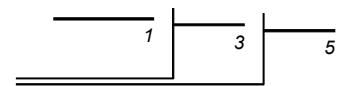

fig. 3

Part two is arranged on two levels (fig. 4). The first gives the acronym of the family to which the technical sheet belongs; the number that follows indicates technical sheet order sequence inside each family.

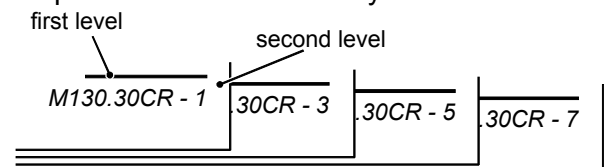
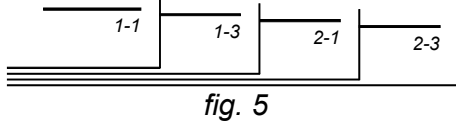

fig. 4

Part three is also arranged on two levels (fig. 5); the first is a number assigned to each component, the second indicates technical

sheet order sequence. Correspondence between component and number is given in the index at the beginning of part three.



**4 Updating**

The evolution of Biasi products entails updating the technical assistance personnel and relative documentation.

The updated documentation which will be sent to the Assistance Service Centres, whether in the shape of a circular or technical sheets to be added to the manual or to replace others, must be properly inserted.

All technical service personnel must be informed immediately of their contents.

**5 Models**

All models of products manufactured are identified with a name. This name (*from here referred to as model*) is determined by the unit construction characteristics (fig. 6)

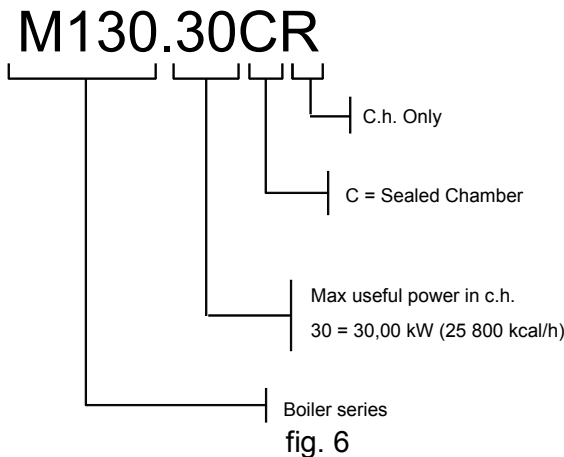

The information contained in this manual is applicable to the following models:

M130.30CR

**6 Serial number**

Each unit has its own serial number, the meaning of which is given in fig. 7.

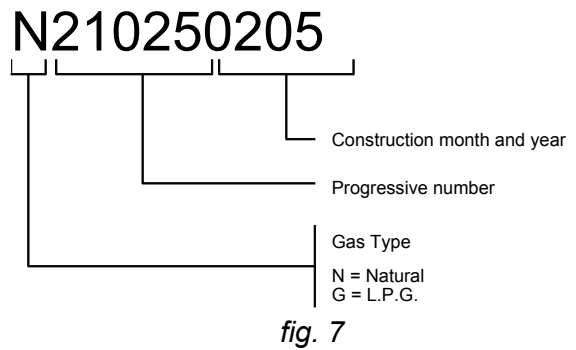

**7 Series**

The boilers are grouped into families in part two of this manual, each group including models with identical construction features and, hence, with identical maintenance.

Within each family the models differ only in their nominal thermal capacity or other characteristics that do not call for different maintenance.

Series	Models
M130-----	M130.30CR

## Summary

	Page
OVERALL VIEW.....	M130.30CR - 1
HYDRAULIC DIAGRAM.....	M130.30CR - 1
ELECTRICAL DIAGRAM.....	M130.30CR - 2
GAS ADJUSTMENT DATA.....	M130.30CR - 3
FAULT FINDING.....	M130.30CR - 4
CIRCUIT VOLTAGES.....	M130.30CR - 5
OPERATION LIGHTS.....	M130.30CR - 6
START UP CHECKS.....	M130.30CR - 6
GAS CONVERSION.....	M130.30CR - 7



**1 Overall View**

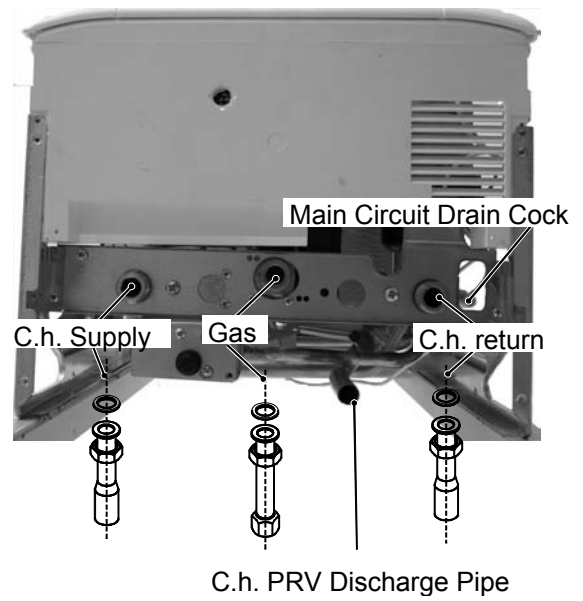
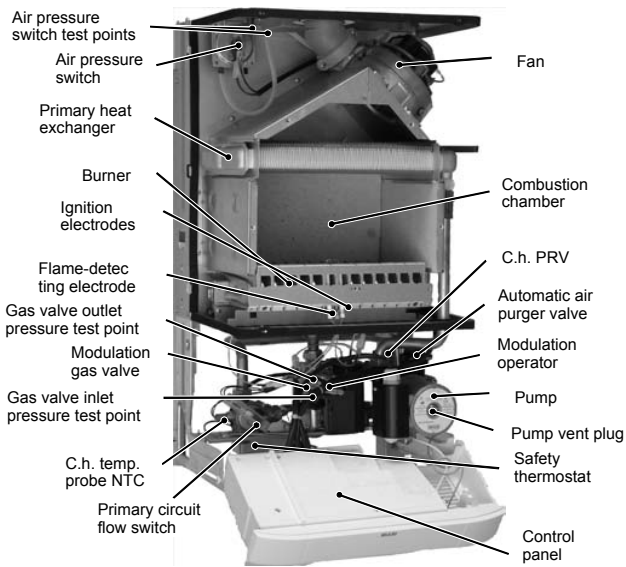

fig. 1

**2 Hydraulic Diagram**

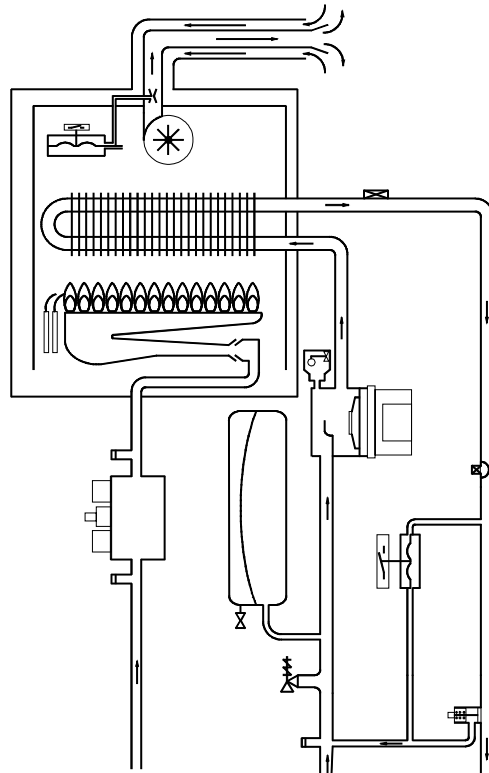

fig. 2

**3** Electrical Diagram

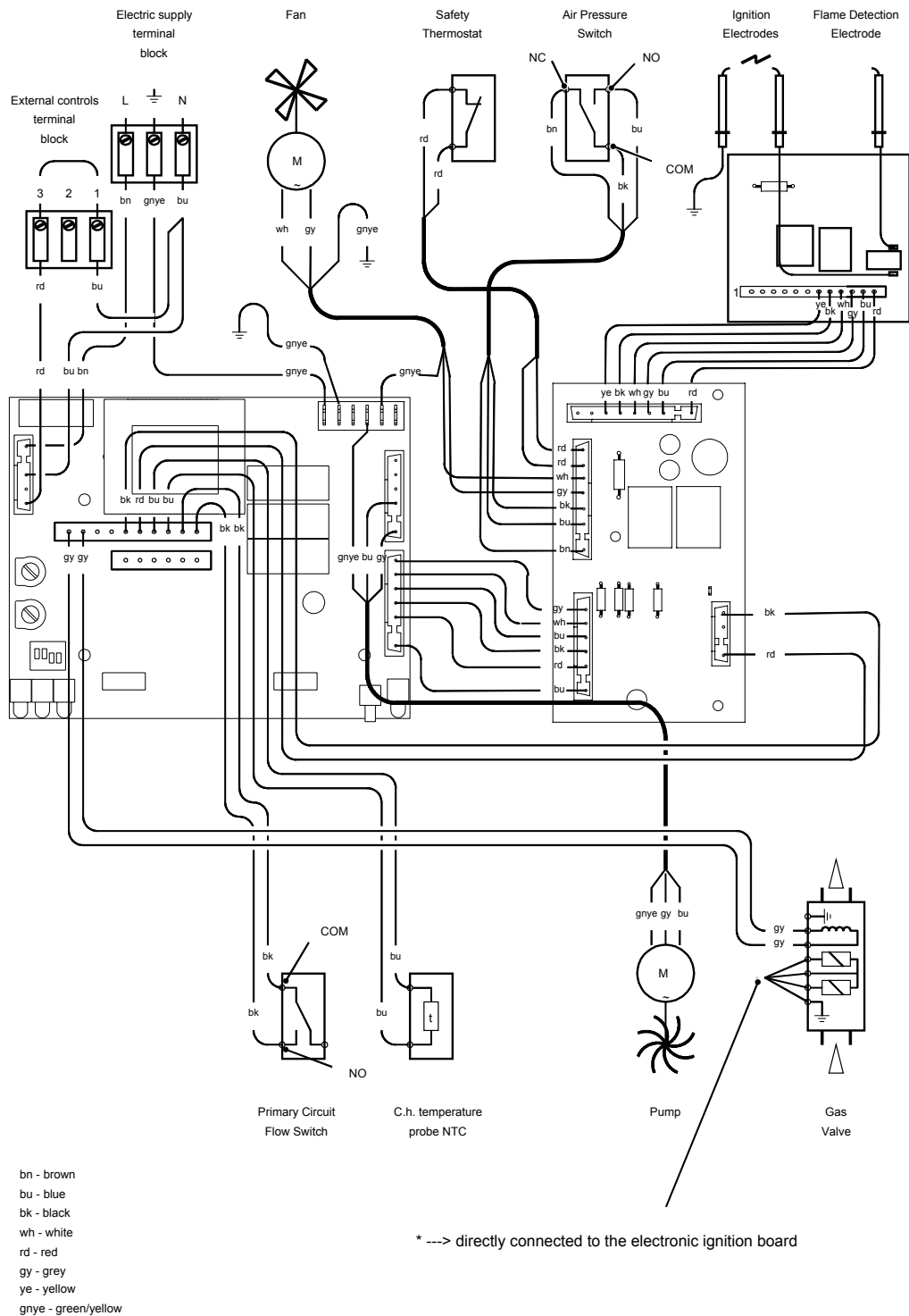

fig. 3



**4 Gas Adjustment Data**

<b>Maximum gas pressure at the injectors</b> Natural (G20) Propane (G31)	inwc inwc	5.3 9.0
<b>Minimum gas pressure at the injectors</b> Natural (G20) Propane (G31)	inwc inwc	0.8 1.4
<b>Ignition pressure</b> Natural (G20) Propane (G31)	inwc inwc	2.4 5.2
<b>Maximum gas rate</b> Natural (G20) Propane (G31)	ft <sup>3</sup> /h lb/h	121.1 5.55
<b>Minimum gas rate</b> Natural (G20) Propane (G31)	ft <sup>3</sup> /h lb/h	48.7 2.23
<b>Injectors</b> Natural (G20) Propane (G31)	n°/Φ	14/130 14/89

<b>Useful output</b>	KW Kcal/h	10.8 9288	12.0 10320	14.0 12040	17.0 14620	20.0 17200	23.0 19780	26.0 22360	29.5 25370
Natural	Pa	220	250	330	470	640	830	1050	1330
	inwc	0.88	1.00	1.32	1.89	2.57	3.33	4.22	5.34
	m <sup>3</sup> /h	48.7	53.0	60.7	72.4	84.0	96.0	107.7	121.1
Propane	Pa	360	420	560	800	1080	1400	1760	2230
	inwc	1.45	1.69	2.25	3.21	4.34	5.62	7.06	8.95
	lb/h	2.2	2.4	2.8	3.3	3.9	4.4	4.9	5.5

**5** Fault Finding

Section of the manual (third part of manual) → (Note ref. in brackets)	Components to check																								
	(1)	(2)	(3)	(4)	3-1	4-1			5-1	6-1	7-1	8-1	10-1	11-1	12-1	13-1	(7)	(8)	(9)	(10)					
Defect ↓	Power Supply Line	Gas Supply Line	Fue Pipes	C/h. Circuit	Central heating circuit (filling)	Pump	Fuses (Control p.c.b.)	Function Selectors (control p.c.b.)	Control p.c.b.	Full Sequence Device	Fan and Air Pressure Device	Gas valve (on-off operators)	Gas valve (modulating operator)	Main Circuit Flow Switch	C/h. Temperature Probe NTC	By-pass Valve	Fan and Venturi Device	Air Pressure Switch	Ignition Electrode	Detection Electrode	Safety Thermostat	Injectors	C/h. Expansion Vessel	C/h. Pressure Relief Valve	C/h. Temp. and Pres. Gauge
Lock-out signal lamp red	■	■								■		■	■						■	■	■				
By pressing the reset push – button the boiler turns on and operates correctly.																									
By pressing the reset push – button the boiler starts the ignition cycle. The burner <b>doesn't light on</b> , the ignition sparks continue and the boiler locks again.	■	■								■		■	■						■	■	■				
By pressing the reset push – button the boiler starts the ignition cycle. The burner <b>lights on</b> , the ignition sparks continue and the boiler locks again.	■	■										■	■						■	■	■				
The boiler does not start in c.h. mode. All operation lights OFF. Fan doesn't turn.	■						■																		
The boiler does not start in c.h. mode. Fan turns			■								■														
The boiler does not start in c.h. mode. Fan <b>doesn't</b> turn.											■														
The boiler lights for a short while on c.h.																									
On c.h. mode the temperature of the main circuit reaches 90°C and the c.h. system does not heat.																									
Incorrect modulation		■																							
Noisy boiler																									
The boiler operates correctly but the gas pressure to the burner remains at minimum.		■																							
Water leaks from the c.h. pressure relief valve during operation on c.h.																									
Water leaks from the c.h. pressure relief valve when the boiler is off.																									

Notes:  
 1 Check p.120) – between line (L) and neutral (N). Verify the integrity of supply cable, plug and external fuses. Check the polarity of the line and neutral.  
 2 Verify the soundness of the gas supply pipe, the position of stop valves. Check the gas pressure at the inlet point of the gas valve with the boiler at rest and during operation and compare it with the values given on the installation booklet.

7 Verify the cleanliness of injectors.  
 8 Check the pressurization of the expansion vessel. Refer to the installation manual for proper values.  
 9 If the fan still turns after 30 second from the beginning of flashing of the lock-out lamp it is impossible that the cause of the fault is the fan and air pressure device.  
 10 If the fan doesn't turn before 30 second from the beginning of flashing of the lock-out lamp it is impossible that the cause of the fault is the fan and air pressure device.



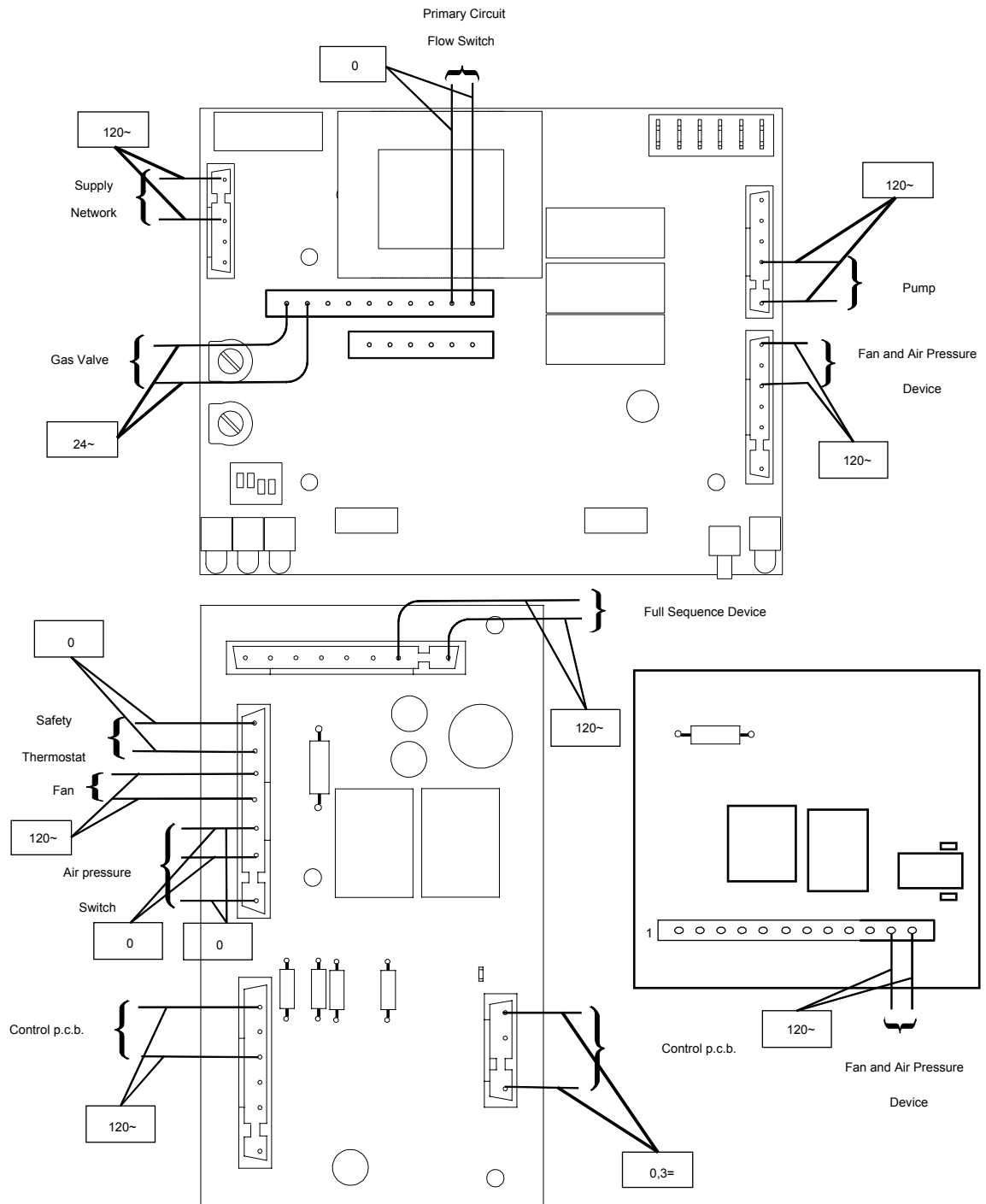

**6** Circuit Voltages











Electrical voltages with burner on



**7 Operation Lights**

The Electronic control p.c.b. is provided with three lamps (LED indicators) that give optical information during the operation of the boiler. The green lamp on the left gives information whether the boiler is in stand-by mode or during the normal operation of the boiler. The following table gives the relationship between the lamp indication and its meaning.

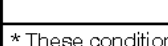
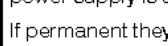
	Boiler in stand-by condition. (function control in 0 position). Anti-freeze system active.
	Boiler ON condition (function control in position)
	
	Normally operating boiler (see the previous table for details)
	C.h. operation

	Frost protect operation
	Faulty c.h. temperature probe NTC
	Faulty primary circuit (no water or absence of flow)
	Lack of burner ignition (no ignition signal from the full sequence ignition device)
	Ignition gas pressure adjustment
	Minimum gas pressure adjustment
	Lack of power supply or faulty electronic control p.c.b. *
	Faulty Electronic control/ignition p.c.b.. *
	Flashing lamp, alone or simultaneously with an other lamp.
	
	Flashing lamp, alternate with another lamp.
	
* These conditions are normal only for a short time when the power supply is applied to the boiler. If permanent they indicate a faulty p.c.b.	

**8 Start-up Checks**

- 1) **Connection to the gas supply system:**  
Check that current regulations have been complied with and that safe running and use are guaranteed.  
Check that there are no leaks.
- 2) **Gas supply pressure:**  
Check gas supply pressure at valve input when the boiler is off and when it is running at full power. Carry out the same check if there are any other user points on.
- 3) **Connection to the electrical system:**  
Check for proper connection to the power supply and to external control devices.  
**Check that the unit is connected to the electrical protection system (earth).**
- 4) **Check the C.h. circuit:**  
Check that the circuit is properly filled at a suitable pressure and that there are no leaks  
Check it is correctly bled of air.
- 5) **Combustion by-product expulsion system:**

- 6) **Correct operation:**  
When starting the boiler check the burner maximum, minimum and ignition gas pressures.  
Check that the Venturi pressure is sufficient to ensure proper operation.  
Check that the unit runs properly in the c.h. mode using the function knob of the control panel.
- 7) **Safety and control devices:**  
Check that safety thermostat, ignition device, air pressure switch, and the main circuit flow switch work properly.
- 8) Instruct the user on how to use the unit correctly and explain to him the functions of the external commands, the actions he needs to take and what to do in case of malfunction or emergency.

**9 Gas Conversion**

- 1) Check that the gas cock fitted on the gas supply pipe is turned off and the appliance is switched off at the circuit breaker.
- 2) Remove the front and side panels of the case.
- 3) Take off the lid of the sealed chamber.
- 4) Remove the front panel of the combustion chamber.

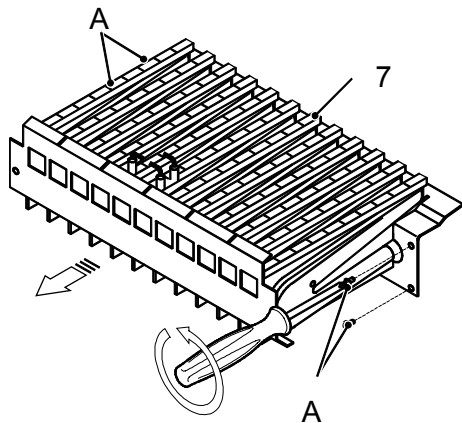

Figure 9.1

- 5) Loosen the screws A and remove the burner 7 (Figure 9.1).
- 6) Carry out the conversion for the type of gas, replacing the burner injectors correctly.
- 7) Reassemble the burner, the front panel of the combustion chamber and the lid of the sealed chamber.
- 8) Extract the control panel.
- 9) Loosen the screws D and remove the service panel (Figure 9.2).

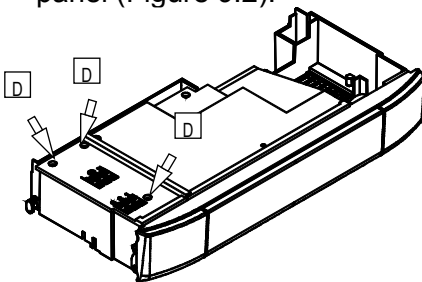

Figure 9.2

- 10) Set correctly the dip-switch "2" to the correct position (Figure 9.3) in accordance with the following table.

Gas supply	Position of the switch 2
Natural gas	On
L.P.G.	Off

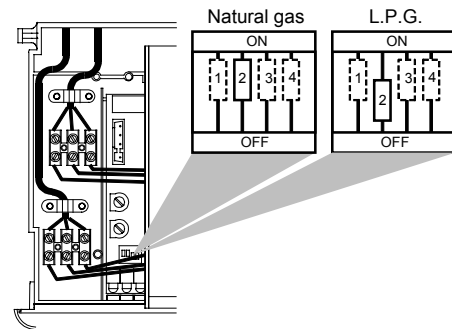

Figure 9.5

- 11) Close the service panel.
- 12) Turn on the boiler.
- 13) Calibrate the gas valve according to the instructions given in the section 7 of the third part of this manual.
- 14) Set the correct gas pressure for central heating output required.
- 15) Stick on the inside of the left hand side panel adjacent to the data badge the self-adhesive label (included with the conversion kit) indicating the type of gas, and the gas pressures to which the appliance has been set.
- 16) Reassemble the front and side panels of the case.



---

---

# Summary

<b>O</b>	<b>General Access and Emptying the Hydraulic Circuits</b>	<b>1-1</b>
	Nomenclature	1-1
	Body Panels	1-1
	Control Panel	1-2
	Access to the Sealed Chamber	1-2
	Emptying the Primary Circuit	1-2
<b>O</b>	<b>Primary Heat Exchanger</b>	<b>2-1</b>
	Function	2-1
	Removal	2-1
	Cleaning	2-2
<b>O</b>	<b>Pump</b>	<b>3-1</b>
	Function	3-1
	Checks	3-1
	Removal	3-1
<b>O</b>	<b>Control p.c.b. 11.62</b>	<b>4-1</b>
	Function	4-1
	Selection and Adjustment Devices	4-1
	Checking the Temperature	4-2
	Operation Lights	4-2
	Dip-switch Selectors	4-3
	Ignition Gas Pressure Adjustment	4-4
	Max C.h. Power Regulation	4-4
	Anti-frost System	4-4
	Hydraulic Parts Checking System	4-4
	Checks	4-4
	Removal of the Control p.c.b.	4-4
	Thermal Control	4-6
<b>O</b>	<b>Fan and Air Pressure Device 11.61</b>	<b>5-1</b>
	Function	5-1
	Checks	5-1
	Removal	5-1
<b>O</b>	<b>Full Sequence Ignition Device S4567A-1019</b>	<b>6-1</b>
	Function	6-1
	Checks	6-1
	Removal	6-1
	Ignition and Control Sequence	6-2
<b>O</b>	<b>Modulating Gas Valve</b>	<b>7-1</b>
	Function	7-1
	Nomenclature	7-1

---



---

Adjustment	7-1
Checks	7-2
Removal of the Gas Valve	7-2
<b>O Primary Circuit Flow Switch</b>	<b>8-1</b>
Function	8-1
Checks	8-1
Removal	8-1
<b>O Expansion Vessel and Temperature-Pressure Gauge</b>	<b>9-1</b>
Function	9-1
Checks	9-1
Removal of the C.h. Expansion Vessel	9-1
Removal of the Temperature-Pressure Gauge	9-1
<b>O Temperature Probe NTC</b>	<b>10-1</b>
Function	10-1
Checks	10-1
Removal	10-1
<b>O Fan, Venturi Device and Air Pressure Switch</b>	<b>11-1</b>
Function	11-1
Checks	11-1
Removal of the Fan	11-2
Inspection and Removal of the Venturi Device	11-2
Removal of the Air Pressure Switch	11-2
<b>O Ignition and Detection Electrodes, Burner and Injectors</b>	<b>12-1</b>
Function	12-1
Checks	12-1
Removal	12-1
<b>O Safety Thermostat</b>	<b>13-1</b>
Function	13-1
Checks	13-1
Removal	13-1
<b>O Electric Resistances</b>	<b>14-1</b>
Pump Resistance	14-1
Gas Valve Resistance	14-1
Temperature Probe NTC Resistance	14-1
Fan Resistance	14-1
<b>O Short Spare Parts List</b>	<b>15-1</b>



**General Access and Emptying Hydraulic Circuits**

- 1) Nomenclature
- 2) Body Panels
- 3) Control Panel
- 4) Access to the Sealed Chamber
- 5) Emptying the Primary Circuit

**1 Nomenclature**

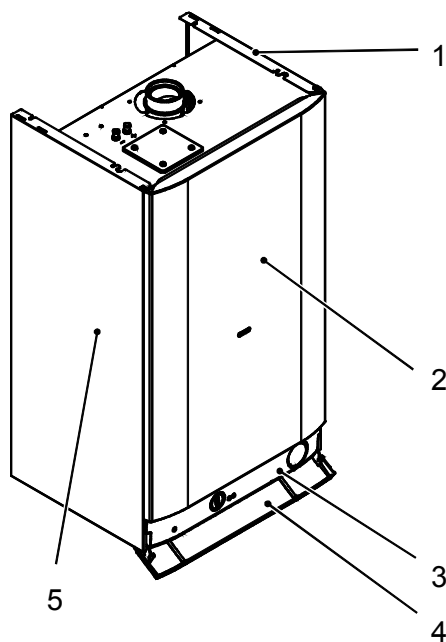

Figure 1

- 1) Right Side Panel
- 2) Front Panel
- 3) Control Panel Lid
- 4) Control Panel Cover
- 5) Left Side Panel

**2 Body Panels**

**Warning: Isolate the boiler from the mains electricity supply before removing any covering or component.**

For the most part of the check and maintenance operations it is necessary to remove one or more panels of the case.

The side panels can be removed only after the removal of the front panel.

To remove the front panel remove screws A (Figure 2) , lift the panel and remove it.

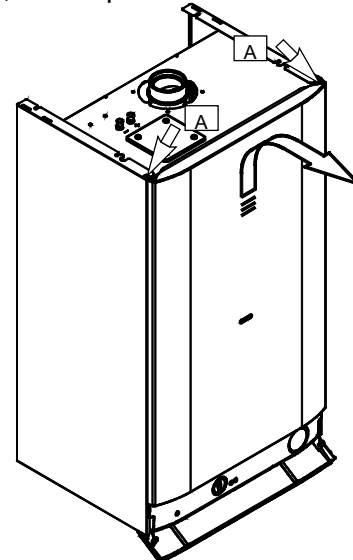

Figure 2

To remove the side panels, remove the screws B (Figure 3) and loosen the screws C (Figure 3), bring the base of the panels away from the boiler (Figure 4) and lift them, freeing them from the top hooks.

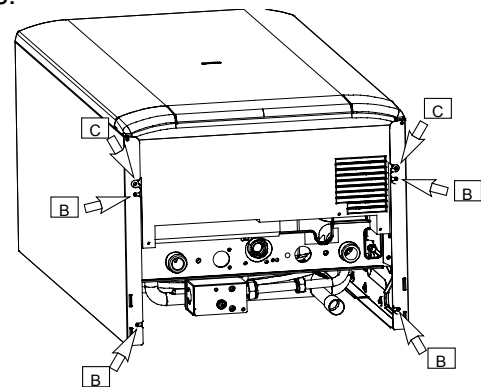

Figure 3

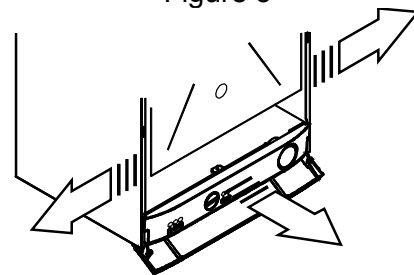

Figure 4

### 3 Control Panel

**Warning: Isolate the boiler from the mains electricity supply before removing any covering or component.**

To gain access to the parts located inside the control panel proceed as follows:

- 1) Remove the front panel of the case.
- 2) Loosen the screws and B and C (Figure 3).
- 3) Move the lower part of the side panels as indicated in Figure 4 and pull the control panel. When completely pulled out, the panel can rotate 45° downwards to facilitate the service operations on the internal parts.

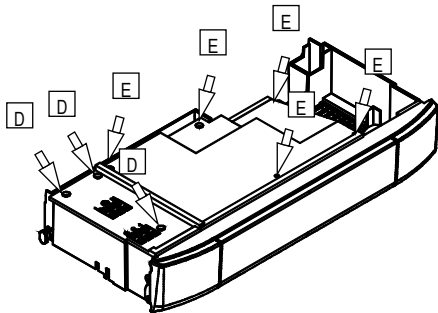

Figure 5

- 4) Remove the screws D and remove the service panel (Figure 5).
- 5) To gain access to the electronic control p.c.b. and the fan and air pressure device remove the screws E and remove the control panel lid (Figure 5).

### 4 Access to the Sealed Chamber

To gain access to the parts contained in the sealed chamber it is necessary to remove the lid of the sealed chamber.

For this purpose, remove the front and side panels of the case, remove the screws F as indicated in Figure 6 and remove the lid.

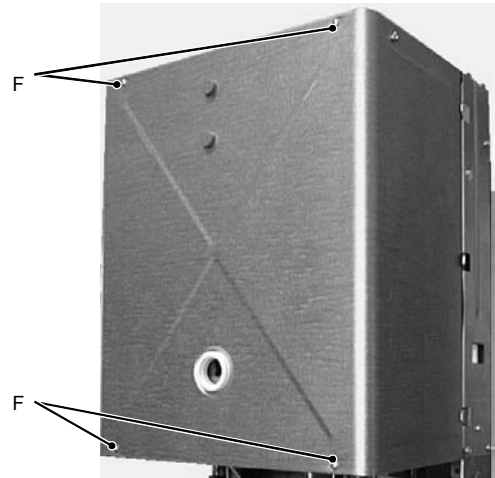

Figure 6

### 5 Emptying the Primary Circuit

- 1) Close the pressure reducing automatic fill valve.
- 2) Open the c.h. drain cock G (Figure 7).
- 3) Empty the C.h. System.
- 4) Close the c.h. drain cock G.
- 5) Open the pressure reducing automatic fill valve.

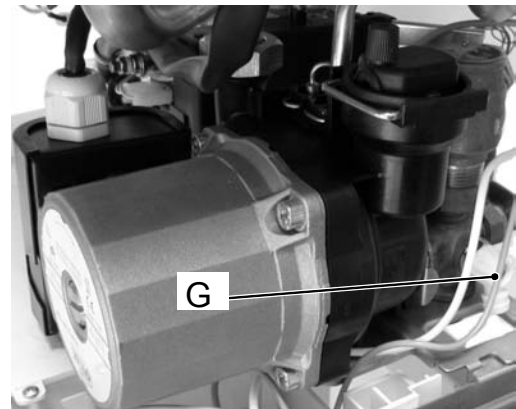

Figure 7

**Primary Heat Exchanger**

- 1) Function
- 2) Removal
- 3) Cleaning

**1 Function**

The primary heat exchanger A in Figure 1 has the function of transferring heat produced from combustion of the gas to the water circulating in it.

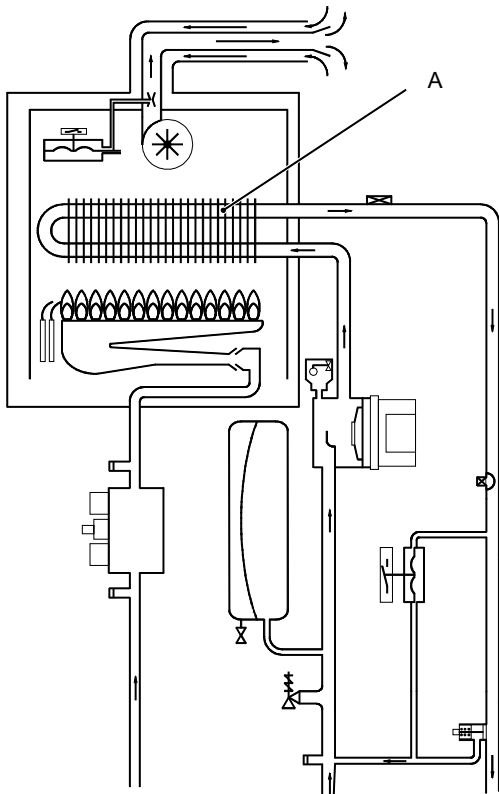

Figure 1

The hydraulic circuit is composed of 8 elliptical pipes connected in parallel (Figure 2).

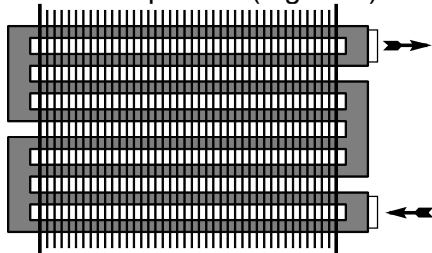

Figure 2

**2 Removal**

- 1) Remove the case panels.
- 2) Empty the primary circuit.
- 3) Remove the sealed chamber lid.
- 4) Remove the front panel B of the combustion chamber by unscrewing the screws C (Figure 3).
- 5) Remove the screw D and the deflector E.
- 6) Remove the clips F (Figure 3).

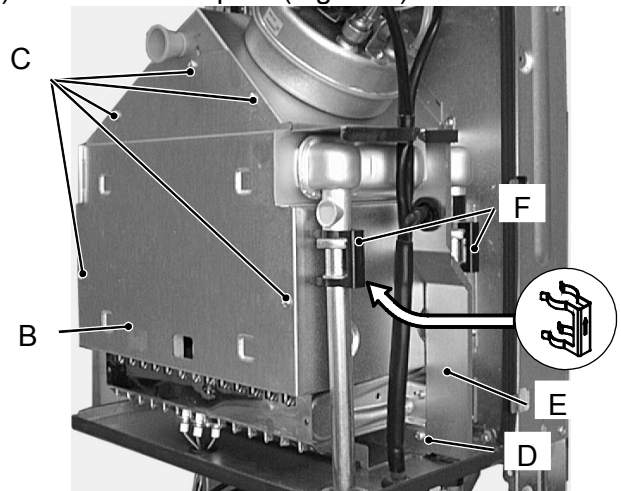

Figure 3

- 7) Loosen the connection G, rotate to the left and then move downwards the pipe H freeing it from the connection of the primary heat exchanger (Figure 4).

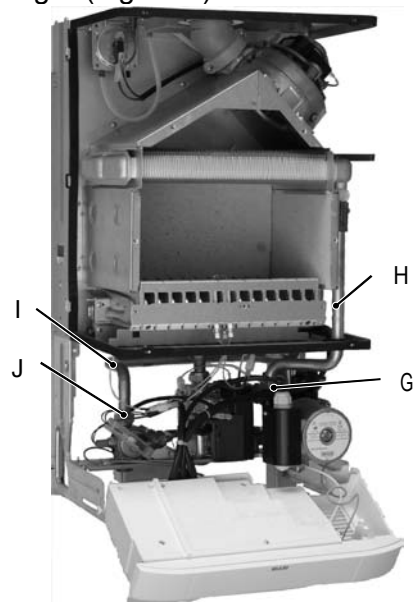

Figure 4

- 8) Completely unscrew the connection J and rotate the pipe I downwards freeing it from the heat exchanger connection (Figure 4)
- 9) Remove the heat exchanger by sliding it forwards.
- 10) Reassemble the boiler carrying out the removal operations in reverse order. Fit the clip F with the arrow pointing upwards as illustrated in Figure 3.

### **3** Cleaning

If there are deposits of soot or dirt between the blades of the heat exchanger, clean with a brush or non-metallic bristle brush.

In any case, avoid any actions that can damage the protective varnish with which the exchanger has been covered.

## Pump

- 1) Function
- 2) Checks
- 3) Removal

### 1 Function

The pump A in Figure 1 has the function of making the water in the main circuit circulate through the main heat exchanger and therefore through the c.h. system.

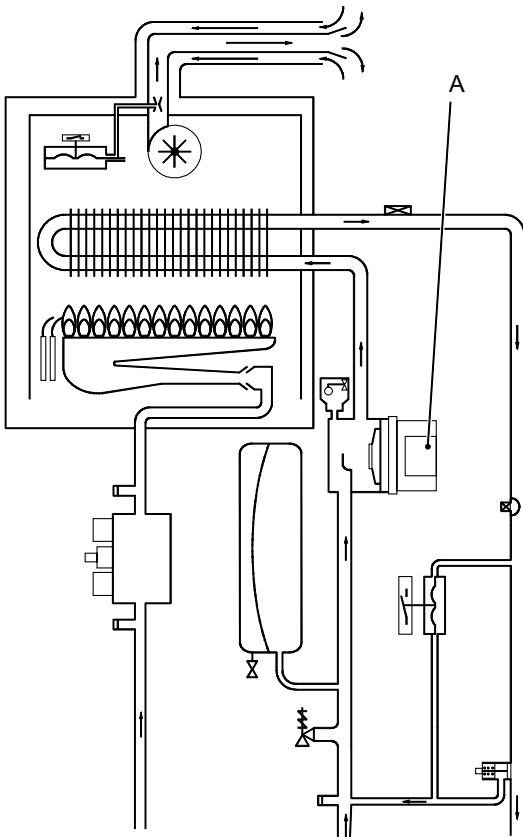

Figure 1

### 2 Checks

**A** Check that the pump is not seized and that the movement of the rotor is not subject to mechanical impediments.

With the boiler off, remove the front panel. Remove the air release plug of the pump and turn the rotor with a screwdriver.

**B** Check the electrical continuity.

With the boiler off, remove the control panel lid as described on page 1-2 of the third part and measure the electrical resistance on the control p.c.b. (Figure 2) removing the pump power supply cable and measuring the resistance of said wiring.

Electrical resistance of the windings (at ambient temperature) must be about 51.7  $\Omega$ .

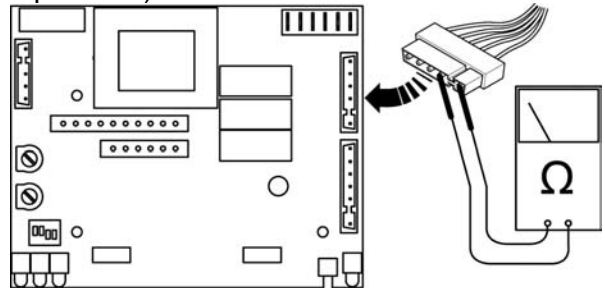

Figure 2

**C** Check the absence of starting defects.

With the boiler off remove the front case panel. Remove the air release plug from the pump. Start the boiler and with a screwdriver, turn the rotor in the direction of the arrow. If there is a defect in starting, the rotor will begin to turn normally only starting it manually.

**D** Check that the impeller is integral with the rotor.

With the boiler off remove the front and right hand side case panels, lower the control panel and empty the primary circuit. Remove the pump head by undoing the screws which hold it to the pump body and check that the impeller is firmly joined to the rotor.

### 3 Removal

- 1) Remove the front and the side panels of the boiler.
- 2) Empty the primary circuit of the boiler.
- 3) Extract and lower the control panel.
- 4) Unscrew the screw B and remove the black case C (Figure 3).

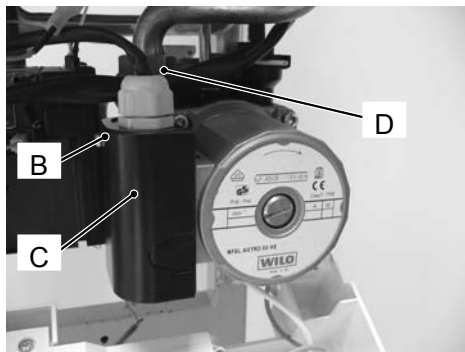

Figure 3

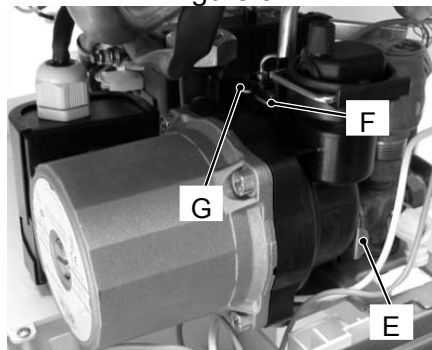

Figure 4

- 5) Loosen the connections D (Figure 3).
- 6) Remove the forks F and G (Figure 4).
- 7) Remove the locking plate E right (Figure 4).



Figure 5

- 8) Loosen the connector H.

- 9) Disconnect the connectors I and pull out the power supply cable from the pump.
- 10) Loosen the connection J and remove the pipe K.

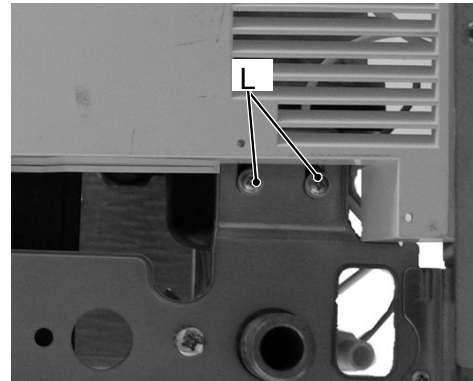

Figure 6

- 11) Unscrew the two screws L that hold the pump on the frame (Figure 6)
- 12) Remove the pump towards the front of the boiler.
- 13) Reassemble the pump carrying out the removal operations in reverse order. When reassembling the pump, check the correct location of the O-ring gasket in the inlet port of the pump that seals the connection between the pump and the brass group.

<p><b>Control p.c.b. 11.62</b></p> <ol style="list-style-type: none"> <li>1) Function</li> <li>2) Selection and Adjustment Devices</li> <li>3) Checking the Temperature</li> <li>4) Operation Lights</li> <li>5) Dip-switch Selector</li> </ol>	<ol style="list-style-type: none"> <li>6) Ignition Gas Pressure Adjustment</li> <li>7) Max C.h. Power Regulation</li> <li>8) Anti-frost System</li> <li>9) Hydraulic Parts Checking System</li> <li>10) Checks</li> <li>11) Removal of the Control p.c.b.</li> <li>12) Thermal Control</li> </ol>
-------------------------------------------------------------------------------------------------------------------------------------------------------------------------------------------------------------------------------------------------	---------------------------------------------------------------------------------------------------------------------------------------------------------------------------------------------------------------------------------------------------------------------------------------------------

**1 Function**

**Inlet Information**

On the Electronic control p.c.b.....

- Function control\*
- C.h. temperature adjustment\*
- Function dip-switches
- Max c.h. power adjustment
- Ignition gas pressure adjustment
- Boiler reset button\*
- \*control panel fascia

---

From other boiler devices....

- C.h. temperature probe NTC
- Primary circuit flow switch
- Room thermostat (if fitted)
- Flame presence signal\*
- \*from the full sequence ignition device



**Outlet command**

- Pump
- Full sequence ignition device
- Modulation operator
- Appliance operation lights\*
- Lock-out signal lamp\*
- \*control panel fascia

The fundamental function of the Control p.c.b. is that of controlling the boiler in relation to the external needs (i.e. heating the dwelling) and operating in order to keep the temperature of the hydraulic circuits constant.

This is obviously possible within the useful power and maximum working temperature limits foreseen.

Generally, the Control p.c.b. receives inlet information coming from the boiler (the sensors) or from the outside (knob, room thermostat, etc.), processes it and consequently acts with outlet commands on other components of the boiler.

**2 Selection and Adjustment Devices**

On the Control p.c.b. several selection, adjustment and protection devices are located. (Figure 1).

Some of these devices are directly accessible by the user (function control, temperature adjustment potentiometers etc.) others are accessible by removing the service panel or the control panel lid.

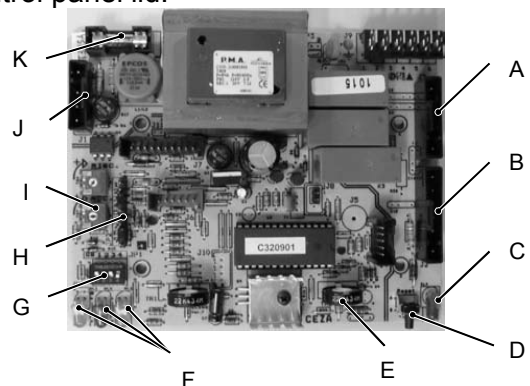

Figure 1

- A) J3 connector
- B) J2 connector
- C) Lock-out signal lamp

- D) Boiler reset button
- E) Function control / C.h. temp. adjustment
- F) Appliance operation lights
- G) Dip-switch selectors
- H) Setting jumpers
- I) Ignition gas pressure adjustment (ACC.)
- J) J1 connector
- K) Fuse 4.0 A

### 3 Checking the Temperature

The control p.c.b. makes it possible to adjust the c.h. water flow temperature. The temperature of the water is converted into an electric signal by means of temperature probes. The user, setting the desired temperature with the control panel knob operates the variable element (E in Figure 1) of the control p.c.b. If the power requested is lower than 40% of the maximum power output then control is achieved by switching ON the burner at minimum power, then switching OFF (ON/OFF function). If the power requested is higher, then the burner is switched ON at maximum power and will control by modulating to 40% of the max power output.

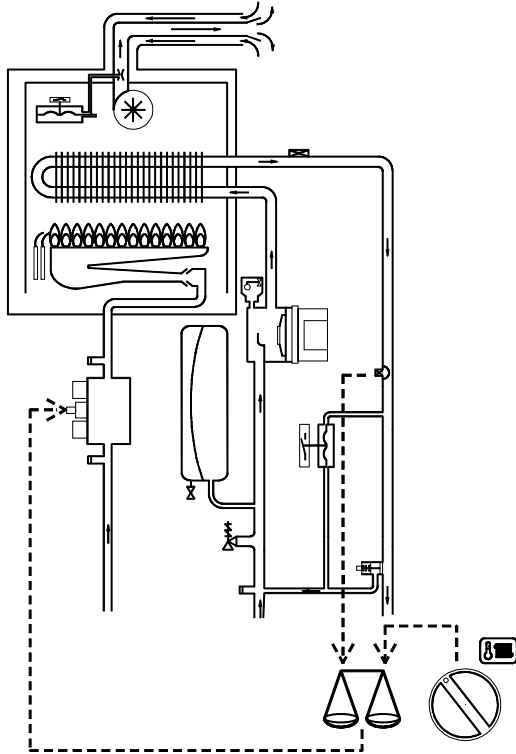

Figure 2

During the c.h. operation (Figure 2), the signal coming from the c.h. temperature probe is compared to the signal given by the control panel through the adjustment made by the user (knob in Figure 2). The result of such a comparison operates the modulation of the gas valve, consequently changing the useful output of the boiler.

The control sequence is illustrated in detail in sections 12.

### 4 Operation Lights

The Control p.c.b. is provided with three lamps (L.E.D. indicators) F in Figure 1 that give optical information during the operation of the boiler. The green lamp on the left gives information whether the boiler is in stand-by mode or during the normal operation of the boiler.

The following table gives the relationship between the lamp indication and its meaning.

<p>A short pulse every 4 seconds</p>	<p>Boiler in stand-by condition. (function control in 0 position).</p> <p>Anti-freeze system active.</p>
<p>1 second ON 1 second OFF</p>	<p>Boiler ON condition (function control in position)</p>

Figure 3

With the boiler switched ON all the lamps (F in Figure 1) are activated.

The following table gives the relationship between each of the possible lamp combinations and their meaning.



	Normally operating boiler (see the previous table for details)
	C.h. operation
	Frost protect operation
	Faulty c.h. temperature probe NTC
	Faulty primary circuit (no water or absence of flow)
	Lack of burner ignition (no ignition signal from the full sequence ignition device)
	Ignition gas pressure adjustment
	Minimum gas pressure adjustment
	Lack of power supply or faulty electronic control p.c.b. *
	Faulty Electronic control/ignition p.c.b.. *
	Lamp OFF      Lamp ON      Flashing lamp, alone or simultaneously      Flashing lamp, with an other lamp.      alternate with another lamp.
* These conditions are normal only for a short time when the power supply is applied to the boiler. If permanent they indicate a faulty p.c.b.	

Figure 4

**5 Dip-switch Selectors**

The function selectors G (Figure 1) are microswitches with which it is possible to select the various boiler control function modes. In Figure 5 the selectors are illustrated in the configuration in which the boiler is set in the factory (natural gas boiler).

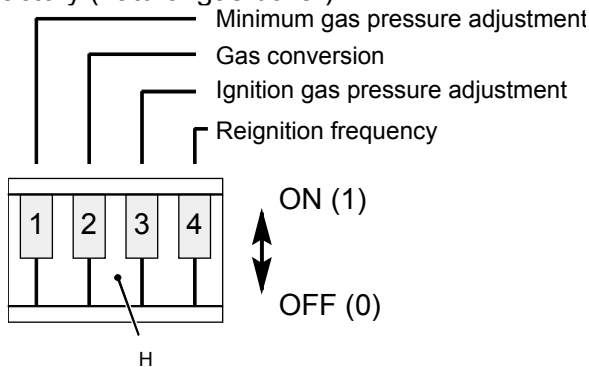

Figure 5

**O Selector 1**  
This forces the boiler to operate at the minimum gas pressure in order to allow the adjustment of the minimum gas pressure at the burner (on the modulation operator of the gas valve). After any adjustment operation the selector has to be brought back to the normal position (ON).

**O Selector 2**  
This selects the boiler functions on the basis of the type of gas used. It allows the selection of the maximum supply current given to the modulator device. To set selector 2 correctly follow the table in Figure 6.

Gas Supply	Position of selector
Natural gas	ON
L.P.G.	OFF

Figure 6

**O Selector 3**  
This forces the functioning of the boiler in order to allow the optimal gas pressure at the burner to be adjusted during the ignition phase. The adjustment is done by means of the potentiometer I marked "ACC" (Figure 1 on page 4-1). After the adjustment operations bring the selector back to the normal position (ON).

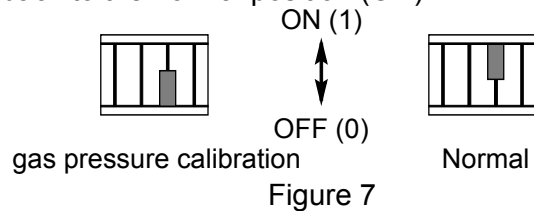

Figure 7

**O Selector 4**  
This allows you to select the minimum time that must pass between two ignitions of the burner in c.h. function.

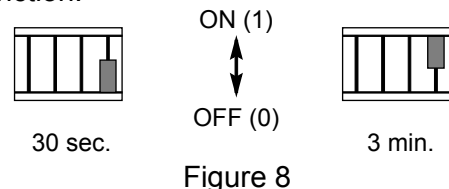

Figure 8

## 6 Ignition Gas Pressure Adjustment

By using the device "I" (Figure 1) marked "ACC.", it is possible to adjust the gas pressure at the injectors in the ignition phase.

This pressure is maintained at the injectors until ignition occurs (ionization signal).

To carry out the adjustment move the function selector 3 to the OFF position (Figure 7) and use the adjustment device "I" (ACC).

Adjust the gas pressure at the injectors to the value indicated in the tables of the User/Installation manual (Technical information section, Gas pressures at the burner table).

By rotating the device clockwise the pressure increases.

Check the regular ignition of the burner by turning the boiler on and off repeatedly.

After the adjustment operations bring the selector 3 back to the normal position ON in Figure 7.

## 7 Max C.h. Power Regulation

By using the device I (Figure 1) marked "RISC.", it is possible to limit the maximum useful output delivered in c.h. function. By rotating the device clockwise the pressure increases.

## 8 Anti-frost System

With the boiler turned on, the anti-frost control is always active, which briefly starts the boiler until shutdown at 35°C (primary circuit), so that the temperature of the c.h. circuit does not drop below 5°C.

The request is signalled by the LED  "F" in Figure 1.

If there is no gas, the pump runs continuously to keep the water from freezing.

This function is also active in standby mode.

## 9 Hydraulic Parts Checking System

With the boiler operating (both in winter function and in summer function) the hydraulic parts checking system is always active.

This system makes it possible to maintain the efficiency of the hydraulic parts (i.e. pump) by activating them in case of long periods of unusing.

It is activated when the boiler is inactive for more than 24 hours.

A) It turns on the pump for 1 minute

## 10 Checks

**A** Check that the fuse is complete

If the control p.c.b. does not supply any device (pump, etc.) check that the fuse K (Figure 1) is complete.

If the fuse has blown replace it with one that has the same characteristics after having identified the reason for failure.

**B** Check the setting jumpers position

Two setting jumpers must be fitted on the Control p.c.b. as shown in Figure 9.



Figure 9

The numbers refer to the marking printed on the circuit board.

## 11 Removal of the Control p.c.b.

**Warning: Isolate the boiler from the mains electricity supply before removing any covering or component.**

- 1) Gain access to the parts located inside the control panel as explained on page 1-2 of the third part of this manual.
- 2) Remove all the wiring connected to the Control p.c.b.. To disconnect the connectors J1, J2 and J3 (A,B and J in Figure 1) delicately flex the hook present on one side of each socket.
- 3) Remove the spindles of the c.h. temperature adjustment knob by delicately pulling it with pliers in the direction shown by the arrow in Figure 10.

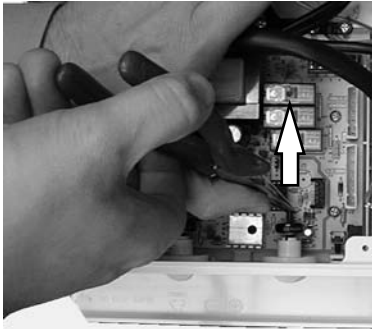

Figure10

- 4) Unscrew the four screws that hold the Control p.c.b. on the control panel.
- 5) Remove it by lifting its rear edge and freeing it from any of the wiring.
- 6) Re-assemble the Control p.c.b. following the removal procedures in the reverse order.

### Important

When re-assembling the Control p.c.b.:

- 7) Fit the p.c.b. into the control panel by first inserting the front lower edge under the control knob shaft. Lower the rear edge and ensure that no wiring is trapped beneath.
- 8) Insert the spindle in the control panel knob until the notch M (Figure 11) reaches the potentiometer edge. It is not necessary to force it in the knob.
- 9) While tightening the screws that fix the Control p.c.b. on the control panel, keep the p.c.b. towards the control panel fascia making sure

of the contact between the boiler reset button N and the tab O (Figure 12).

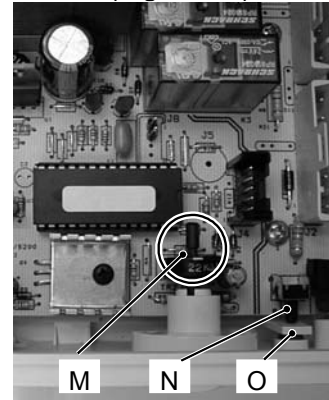

Figure 11

### Attention

After installing the Control p.c.b. :

- 10) Make sure the c.h. temperature adjustment knob can move freely for the complete range. If not, remove the spindle again as described at step 3, turn the knob half a turn and re-insert the spindle.
- 11) Operate the boiler and close the gas supply so that the boiler goes into the safety lock-out state. Verify the correct operation of the boiler reset button by pressing and releasing it.

**12 Thermal Control**

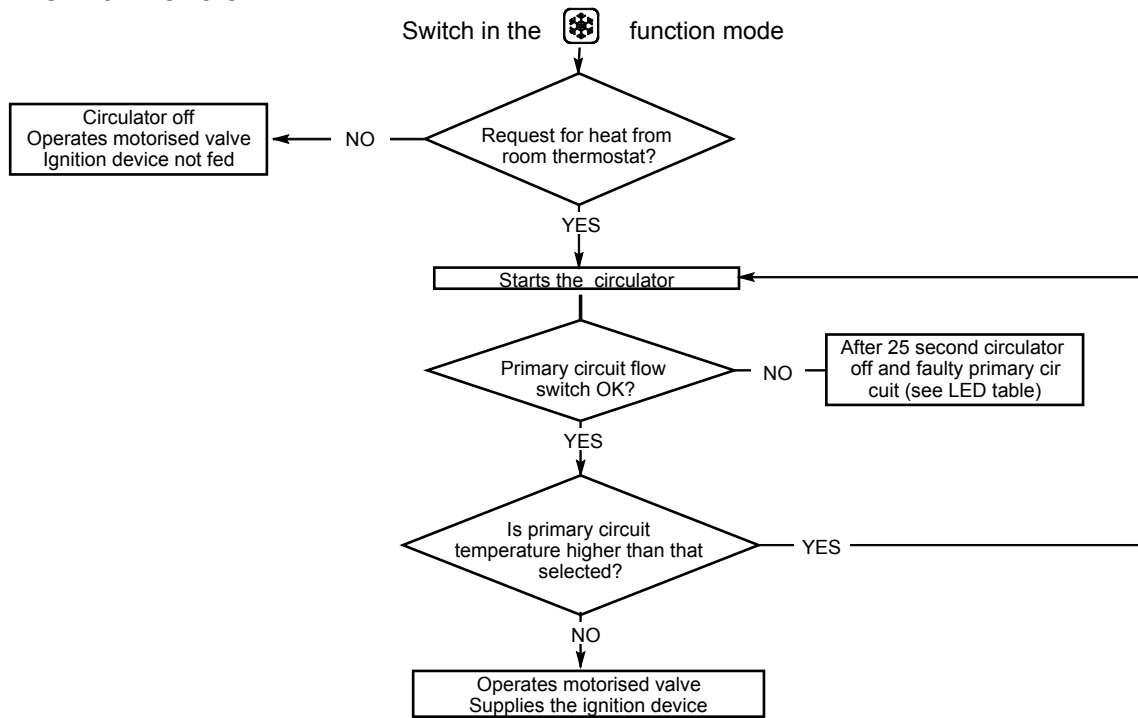

**Fan and Air Pressure Device 11.61**

- 1) Function
- 2) Checks
- 3) Removal

**1 Function**

The Fan and air pressure device A (Figure 1) used on the boiler carries out the following fundamental functions:

- supplies the fan and checks its functioning by means of the signal coming from the air pressure switch.
- supplies the air pressure switch and makes it commutate.
- supplies the safety thermostat.

The Fan and air pressure device is supplied by the electronic control p.c.b. see Second part of this manual chapter 6 (Circuit Voltages).

The Fan and air pressure device also has a safety function and any wrong interventions or tamperings could cause the boiler to function under hazardous operating conditions.

The Fan and air pressure device can lock the functioning of the boiler (lock state) and stop its functioning up to the resetting intervention. The lock is signalled by the lighting of the lock-out signal lamp and the device can be reset only by using the boiler reset button and the function knob placed on the control panel.

Some components which are connected to the device can activate the lock state. The causes of a lock state could be:

- The intervention of the safety thermostat (overheat of the primary circuit).
- The air pressure switch can temporarily stop the ignition of the burner but allow its ignition when the cause of the intervention has stopped.

**2 Checks****A Fan and Air Press. Switch functioning device**

With the boiler operating and the burner on, open the negative pressure test point of the Venturi device.

At the moment of opening the burner must turn off.

**B Checking Voltages**

Refer to Second part of manual chapter 6 to determine the connector pins where to check the supply voltages.

**3 Removal**

Figure 1

- 1) Remove the front panel of the case and lower the control panel.
- 2) Open the control panel as explained in the first section of the third part (General access and emptying hydraulic circuits).
- 3) Disconnect the connectors B,C,D,E by delicately flexing the hook present on one side of each socket.
- 4) Loosen the screws F and remove the device.
- 5) Re-assemble the device following the removal procedures in the reverse order.

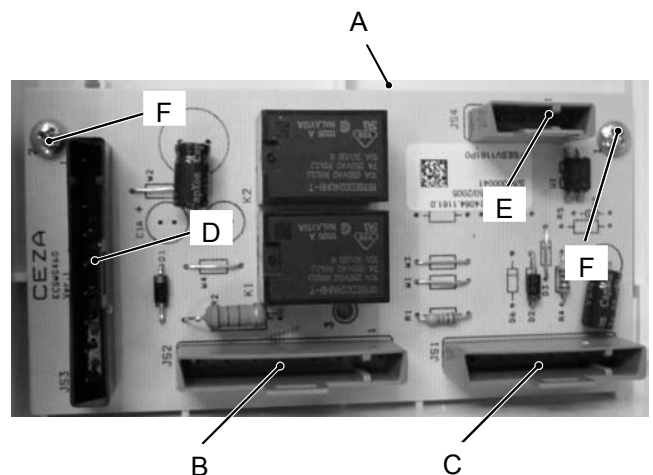

## Full Sequence Ignition Device S4567A-1019

- 1) Function
- 2) Checks
- 3) Removal
- 4) Ignition and Control Sequence

### 1 Function

The Full sequence ignition device A (Figure 1) used on the boiler carries out the following fundamental functions:

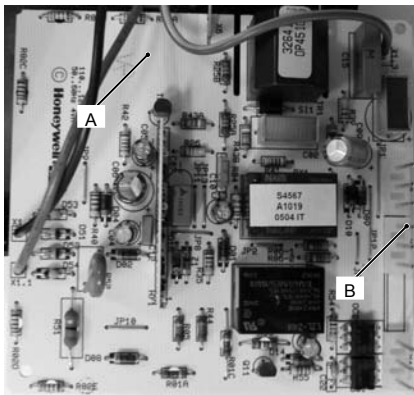

Figure 1

- does a sequence of operations (ignition cycle) which lead to the ignition of the gas at the burner.
- checks the presence of the flame during the entire period in which it is activated.

The Full sequence ignition device is supplied by the fan and air pressure device when the ignition of the burner is requested (see Second part of this manual chapter 6, Circuit Voltages).

The Full sequence ignition device has a safety function and any incorrect interventions or tampering can result in conditions of dangerous functioning of the boiler.

The Full sequence ignition device can lock the functioning of the boiler (lock state) and stop its functioning up to the resetting intervention. The lock is signalled by the lighting of the lock-out signal lamp and the device can be reset only by using the boiler reset button and the function knob placed on the control panel.

The ignition device has some components connected to it which can cause triggering of the shutdown condition; these components are:

- the modulating gas valve;
- the flame detection electrode.

The causes of a lock state could be:

- A fault on gas supply.
  - Faulty ignition (faulty ignition electrodes, their wiring or connection).
  - Faulty flame detection (faulty detection electrode, its wiring or connection).
  - Gas injectors blocked.
  - Faulty modulation gas valve (faulty on-off operators or not electrically supplied).
  - Faulty Full sequence ignition device.
- Section 4 shows the sequence of the operations that are carried out at the start of every ignition cycle and during normal functioning.

### 2 Checks

#### A Lock sequence

- 1) Start the boiler until the burner is ignited.
- 2) With the burner firing, interrupt the gas supply. The Full sequence ignition device must carry out a complete ignition cycle and then stop.
- 3) By turning the boiler on and off by means of the function switch the device must not unlock and the burner must not turn on.

### 3 Removal

- 1) Remove the front body panel and tilt the card holder panel.

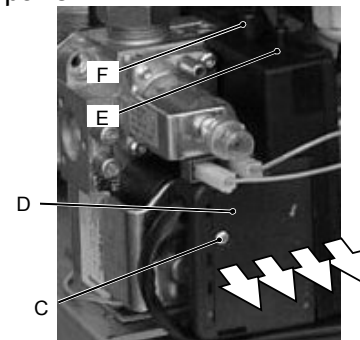

Figure 2

- 2) Unscrew the screw C and remove protection cover D of the connection; disconnect flame detection cable E and ignition cable F (Figure 2).

3) Remove the connector G (Figure 3).

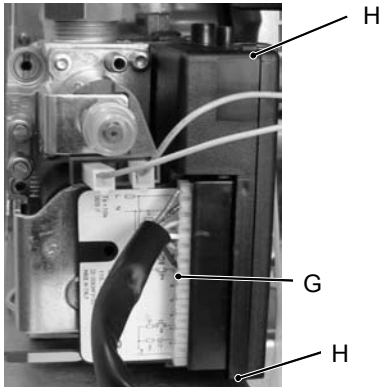
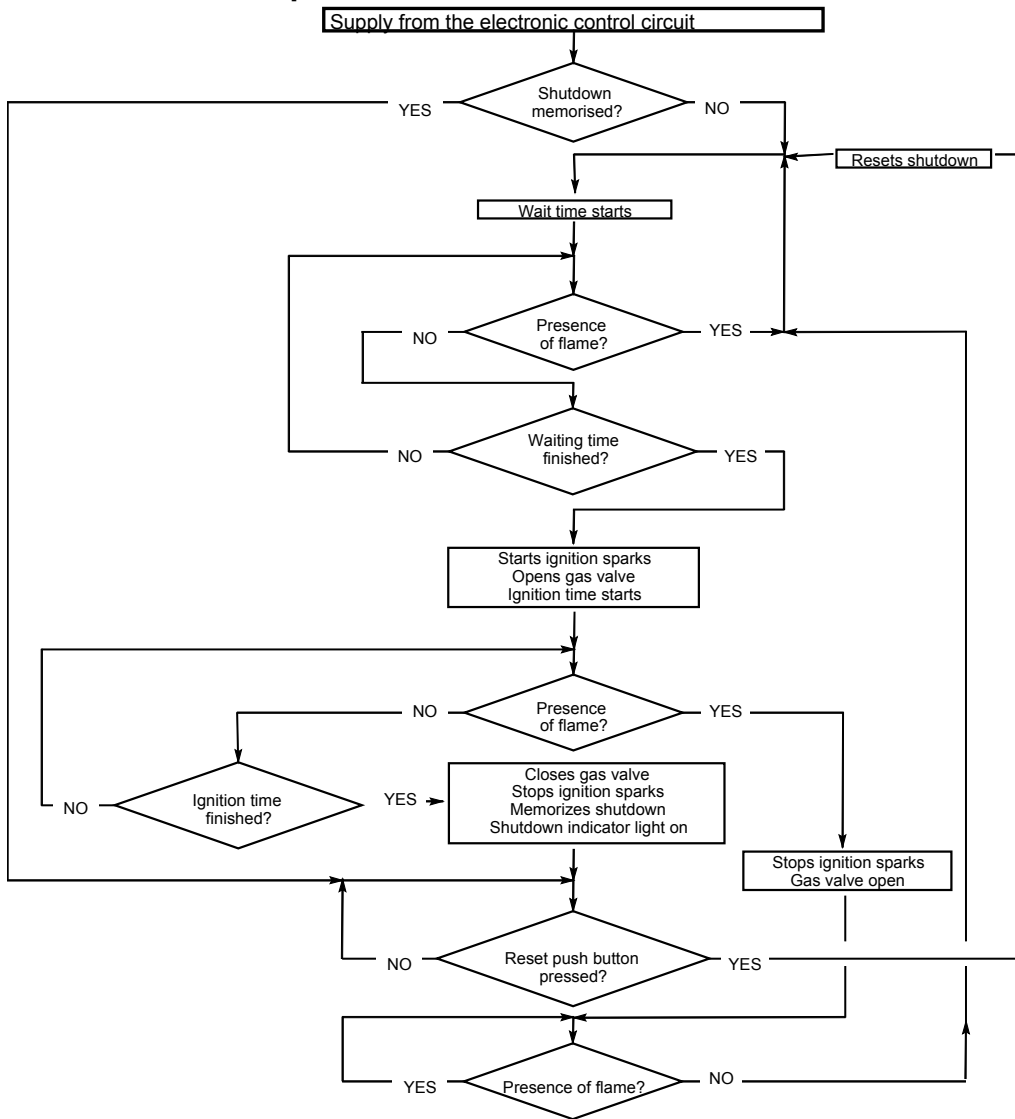

Figure 3

- 4) Pull the ignition device out, pulling it frontally (follow the arrows on Figure 2).
- 5) With the help of a screwdriver open the four clamps H (two on top and two on bottom of the device) (Figure 3).
- 6) Re-assemble the device following the removal procedures in the reverse order.

**4 Ignition and Control Sequence**





## Modulating Gas Valve

- 1) Function
- 2) Nomenclature
- 3) Adjustment
- 4) Checks
- 5) Removal of the Gas Valve

- B Minimum gas pressure adjustment.  
 C Maximum gas pressure adjustment.  
 D Modulation operator's electric connectors.  
 E On-off operators electric connector.  
 F On-off operators.  
 G Gas valve inlet pressure test point.  
 H Gas valve outlet pressure test point.  
 I Modulation operator.

### 1 Function

The Modulating gas valve A in Figure 1 controls the gas inflow to the boiler burner.

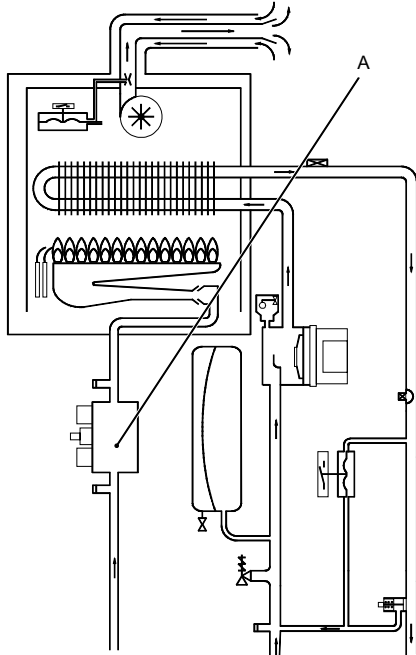

Figure 1

By means of an electric command given to the on-off operators the passage of the gas through the Modulating gas valve can be opened or closed.

By means of an electric command given to the modulation operator the pressure can be varied and therefore the gas flow rate to the burner (modulation). The modulation operator has mechanical components which allow the adjustment of the minimum and maximum pressure exiting the valve.

### 2 Nomenclature

### 3 Adjustment

**Warning: isolate the boiler from the mains electricity supply before removing any covering or component.**

- 1) Remove the front panel of the case.
- 2) Open the gas valve inlet pressure test point (G in Figure 2) at the valve input, connect a suitable pressure gauge and check the gas pressure of the supply network.
- 3) Remove the gauge and close the pressure test point G.
- 4) Open the gas valve outlet pressure test point (H in Figure 2) and connect the gauge.

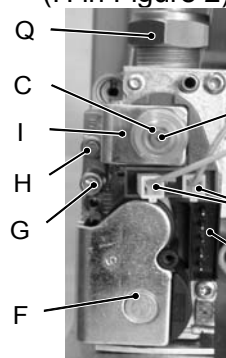

Figure 2

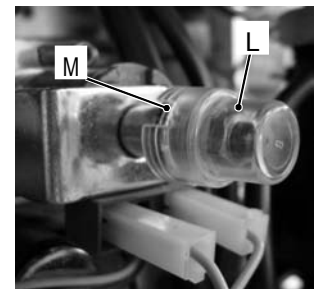

Figure 3

- 5) Remove the protection cap L (Figure 3) from the mechanical pressure adjustment components levering with a flat screwdriver in the slots M.
- 6) Start the boiler at its maximum power. Ensure that the boiler is not range rated.
- 7) Rotate the maximum gas pressure adjustment (C in Figure 2) until you obtain the required pressure (by rotating clockwise the pressure increases).
- 8) Turn the boiler off and disconnect one of the two connectors (D in Figure 2).

- 9) Start the boiler and rotate the minimum gas pressure adjustment (B in Figure 2) until you obtain the required pressure (by rotating clockwise the pressure increases).
- 10) Turn the boiler off and re-connect the wire to the modulating operator.
- 11) Start the boiler and check again the maximum gas pressure setting.
- 12) Turn the boiler off and disconnect the gauge.

**Important: after the gas pressure checks and any adjustment operations, all of the test points must be sealed.**

#### 4 Checks

##### A Check the modulation operator coil

- 1) Remove the front panel of the case.
- 2) Disconnect the connectors D (Figure 2) from the modulating operator and measure the electrical resistance of the coil. Its electrical resistance value must be approx.  $114 \Omega^*$ .

##### B Check the on-off operators coils

- 1) Remove the front panel of the case.
- 2) Disconnect the Ignition device N (Figure 4).
- 3) Measure the electrical resistance between the connector pins of the on-off operators as illustrated in Figure 5.

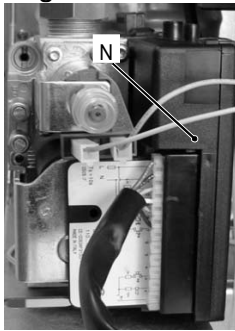

Figure 4

On-off operator  
approx.  $1122 \Omega^*$

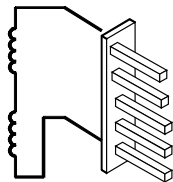

Figure 5

\* at ambient temperature

#### 5 Removal of the Gas Valve

- 1) Remove the front panel of the case.
- 2) Disconnect the connector D (Figure 2) and remove the full sequence ignition device N (Figure 4)
- 3) Turn off the gas supply and remove the gas supply pipe O (Figure 6).

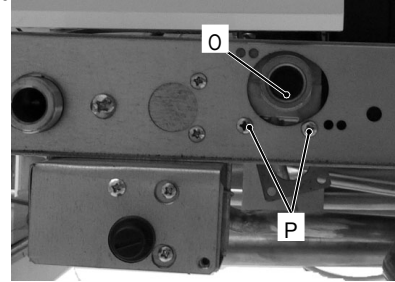

Figure 6

- 4) Loosen the connections Q (Figure 2 and 7) and R (Figure 7).

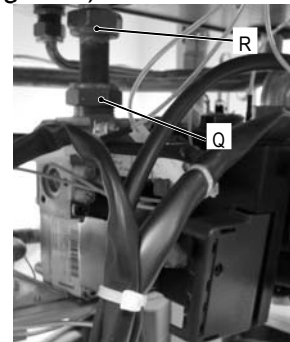

Figure 7

- 5) Remove the gas pipe above the gas valve.
- 6) Loosen the screws P (Figure 6).
- 7) Remove the gas valve.
- 8) Reassemble the gas valve carrying out the removal operations in reverse order.

**After any service operation on the components of the gas circuit check all the connections for gas leaks.**

**Warning: After cleaning or replacement as detailed above, if it deemed necessary to undertake a combustion analysis.**

## Primary Circuit Flow Switch

- 1) Function
- 2) Checks
- 3) Removal

### 1 Function

The Primary circuit flow switch (A in Figure 1) function is to detect water flow rate through the primary hydraulic circuit of the boiler.

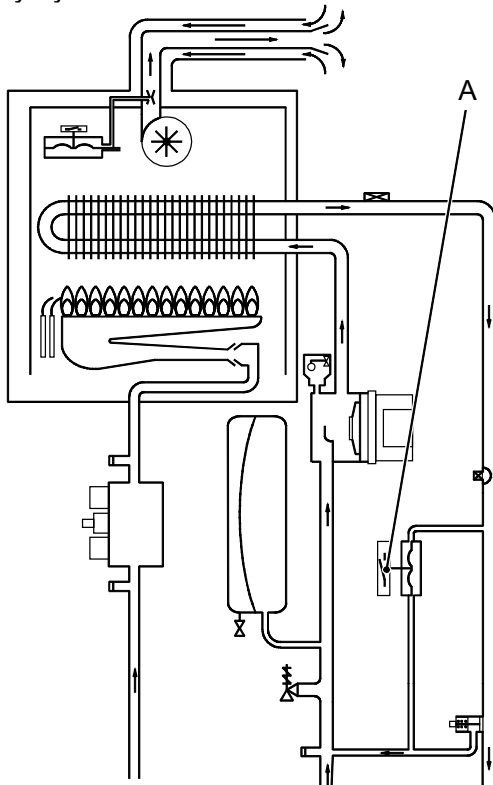

Figure 1

This hydraulic/membrane operated electrical micro-switch device will control the functioning of the ignition control circuit, providing there is an adequate quantity and flow of water in the primary circuit. Any failure of the pump or obstructions in the primary circuit will not allow the device to operate.

This device is connected to the electronic control p.c.b. and if, after the pump operates, it does not activate within 30 seconds the control board will indicate that a fault condition has occurred.

### 2 Checks

**Warning:** Isolate the boiler from the mains electricity supply before removing any covering or component.

#### A Mechanical function

- 1) Remove the front panel of the case.
- 2) Start and stop the boiler.
- 3) Looking through the switch box verify the position of the shaft B referring to Figure 2.

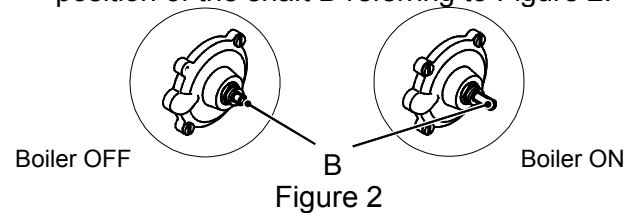

#### B Electrical check

It is possible to verify the general operation of the switch by measuring the electric resistance between the contacts C. and N.O. of the switch.

- 1) Remove the switch as explained in next section.
- 2) Measure the electrical resistance between the tabs marked C. and N.O. (Figure 3). The contact must be normally open.
- 3) Operate the switch by hand and verify that the contact is now closed.

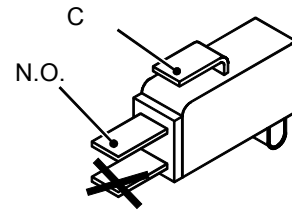

Figure 3

### 3 Removal

**Warning:** Isolate the boiler from the mains electricity supply before removing any covering or component.

#### A Removal of the switch

- 1) Remove the front panel of the case.
- 2) Remove the fork C (Figure 4).
- 3) Open the box D (Figure 4) and disconnect the switch.

- 4) Re-assemble the parts in reverse order of removal. Refer to Figure 3 for the correct wiring connectors on the switch.

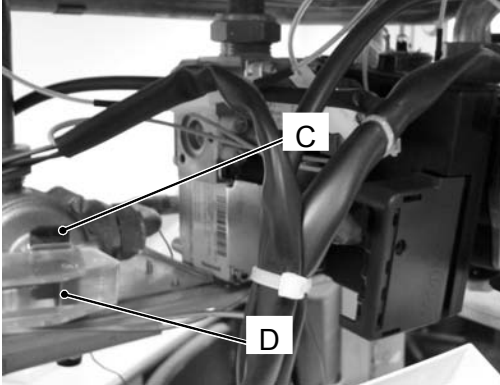

Figure 4

**B** *Removal of the membrane*

- 1) Remove the front and side panels of the case and empty the primary circuit.
- 2) Remove the fork C that holds the micro-switch housing D (Figure 4).
- 3) Unscrew the four screws E (see Figure 5) open the hydraulic operator and remove the membrane F.

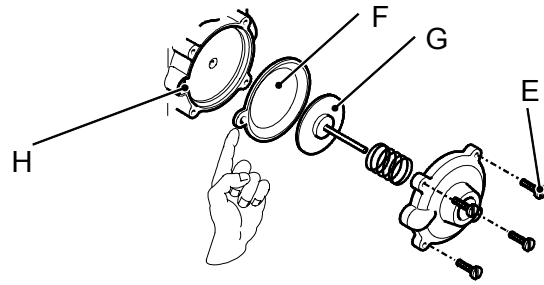

Figure 5

- 4) Reassemble the parts in reverse order of removal.

**When assembling the membrane, ensure that its concave side faces towards the actuator plate G and the reference indicated aligns with the seat H (see Figure 5).**

### Expansion Vessel and Temperature-Pressure Gauge

- 1) Function
- 2) Checks
- 3) Removal of the C.h. Expansion Vessel
- 4) Removal of the Temperature-Pressure Gauge

#### 1 Function

The C.h. expansion vessel (A in Figure 1) function is to allow for the volume expansion of the c.h. circuit water due to the temperature rise.

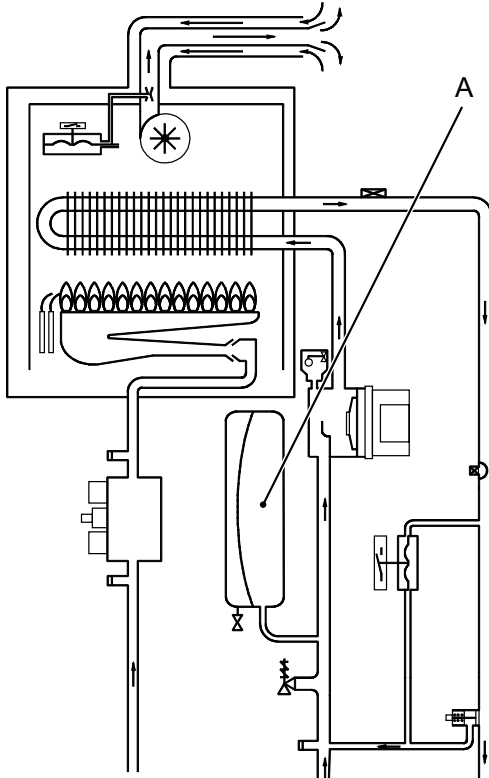

Figure 1

#### 2 Checks

- 1) Empty the primary circuit of the boiler.
- 2) Remove the protective cap C (Figure 2) from the valve on the top of the c.h. expansion vessel and connect a suitable air pressure gauge.
- 3) Check the pre-load pressure. It would be 14.5 psi.

RIVA HEAT ONLY SERVICE MANUAL – REV A

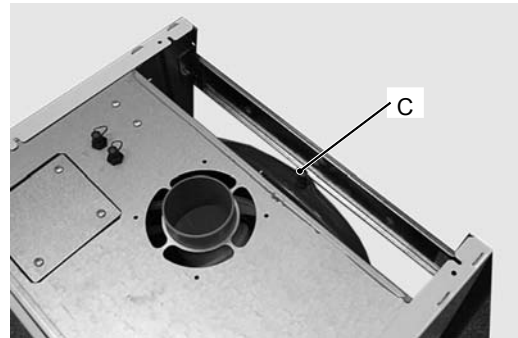

Figure 2

#### 3 Removal of the C.h. Expansion Vessel

- 1) Remove the front panel of the case.
- 2) Completely unscrew the connection D and the lock-nut E and remove the expansion vessel from the top of the boiler (Figure 3).

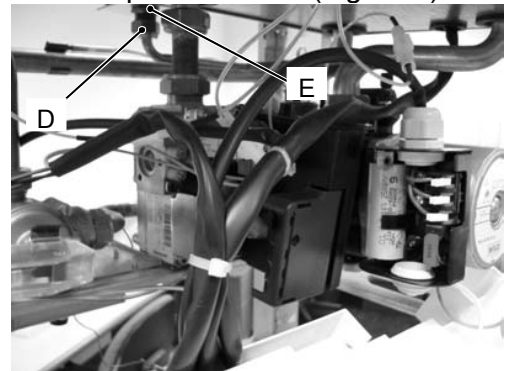

Figure 3

- 3) Re-assemble the parts in reverse order of removal.

#### 4 Removal of the Temperature-Pressure Gauge.

- 1) Remove the front and side panels of the case.
- 2) Empty the primary circuit.
- 3) Remove the fork F and remove the probe G (Figure 4).

---

## Third Part (edition-0106) Expansion Vessel and Temperature-Pressure Gauge

---

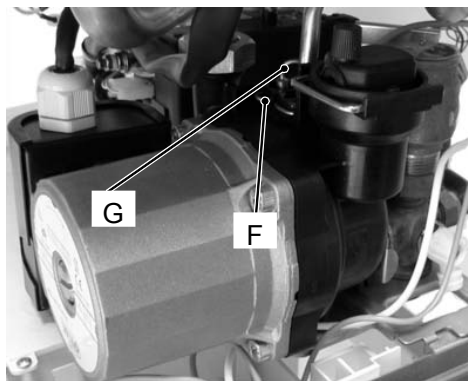

Figure 4

- 4) Remove the probe holder spring H freeing the probe I (Figure 5).



Figure 5

- 5) Squeeze the tabs J to release the temperature-pressure gauge K and remove it (Figure 6).

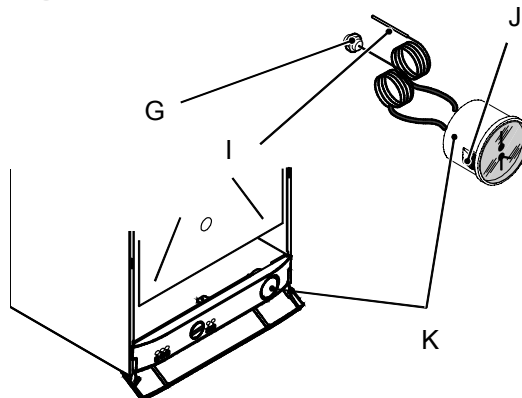

Figure 6

- 6) Re-assemble the parts in reverse order of removal.

## Temperature Probe NTC

- 1) Function
- 2) Checks
- 3) Removal

If the temperature that the NTC give to the control p.c.b. is more than 100°C, the NTC is probably in short circuit.

If the temperature that the NTC give to the control p.c.b. is less than 0°C, the NTC is probably disconnected or interrupted.

### 1 Function

The Temperature probe has the function of converting the temperature of the water in the hydraulic circuit where it is installed into an electrical signal (resistance). The relation between temperature and electrical resistance is stated in Figure 1.

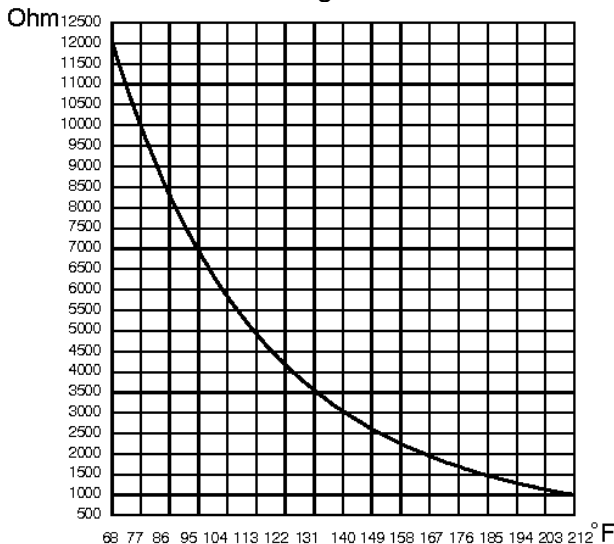

Figure 1

There is one Temperature probe on the output of the primary heat exchanger (A in Figure 2).

### 2 Checks

#### A Temperature-resistance relationship

**Warning: Isolate the boiler from the mains electricity supply before removing any covering or component.**

Disconnect the cable from the Temperature probe.

Measure the temperature of the brass group where the Temperature probe is located and check the electrical resistance according to the graph in Figure 1.

RIVA HEAT ONLY SERVICE MANUAL – REV A

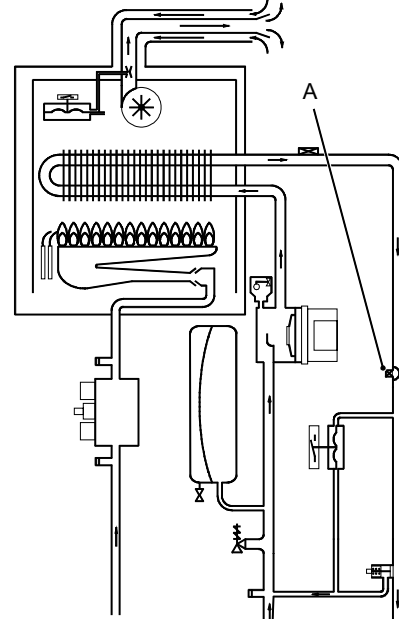

Figure 2

### 3 Removal

**Warning: Isolate the boiler from the mains electricity supply before removing any covering or component.**

- 1) To remove the Temperature probe remove the front panel of the case.
- 2) Empty the primary circuit of the boiler.
- 3) Remove the electric connector of the NTC probe B and unscrew it (Figure 3).

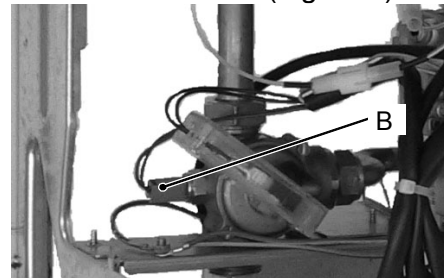

Figure 3

- 4) Reassemble the Temperature probe carrying out the removal operations in reverse order.





**Fan, Venturi Device and Air Pressure Switch**

- 1) Function
- 2) Checks
- 3) Removal of the Fan
- 4) Inspection and Removal of the Venturi Device
- 5) Removal of the Air Pressure Switch

**1 Function**

The function of the Fan A (Figure 1) is to force the products of combustion to the outside air via the flue system.

The Fan is supplied by the Fan and air pressure device at the beginning of the ignition cycle. Its correct functioning is controlled by means of a system incorporating a built in venturi device B and an Air pressure switch C (Figure 1).

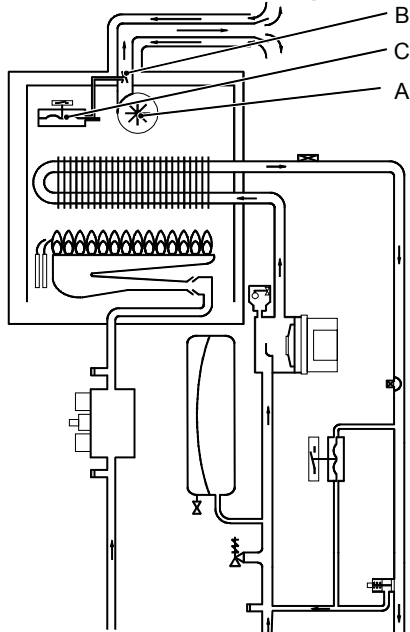

Figure 1

**2 Checks**

**A Check of the fan**

**Warning: Isolate the boiler from the mains electricity supply before removing any covering or component.**

- 1) Remove all the case panels and the sealed chamber lid.
- 2) Disconnect the connectors D (Figure 2) and measure the electrical resistance of the motor that has to be about: 7.2 Ω.

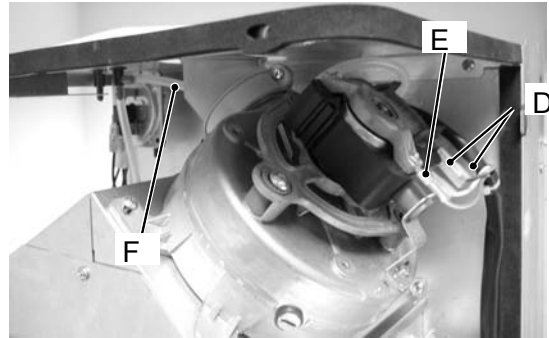

Figure 2

**B Check of the Air pressure switch operation**

**Warning: Isolate the boiler from the mains electricity supply before removing any covering or component.**

- 1) Remove all the case panels and the sealed chamber lid.
- 2) Disconnect the wires and check the electrical resistance between the connections of the Air pressure switch.

Refer to the Figure 3 in accordance with the type of air pressure switch used.

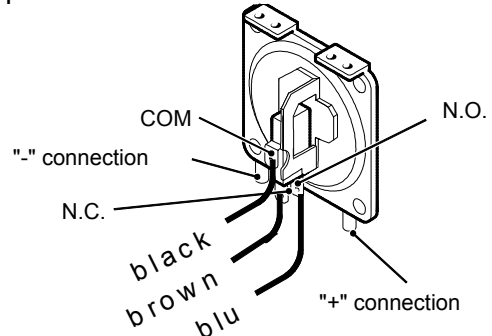

Figure 3

Between COM and N.O. the contact must be open.

Between COM and N.C. the contact must be closed (electrical resistance zero).

- 3) Connect the black (COM) and the brown wire (N.C.).
- 4) Run the boiler (the Fan must run) and check the electric resistance between COM and N.O.. Between COM and N.O. the contact must be closed (electrical resistance zero).

**C Check of the venturi device**

**This test must be carried out with the sealed chamber closed.**

- 1) Remove the caps of the pressure test points located on the top of the boiler and connect a differential pressure gauge (Figure 4).
- 2) Switch on the boiler.

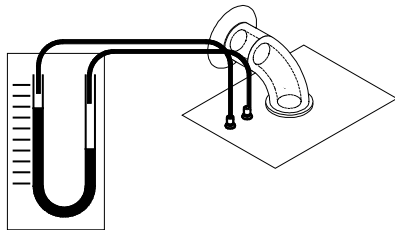

Figure 4

- 3) Compare the value on the gauge with the following minimum value: 0,64 inwc.

**3 Removal of the Fan**

- 1) Remove all the case panels and the sealed chamber lid.
- 2) Disconnect the connectors D and E (Figure 2).
- 3) Disconnect the pipe F which connect the venturi device to the pressure test point (Figure 2).

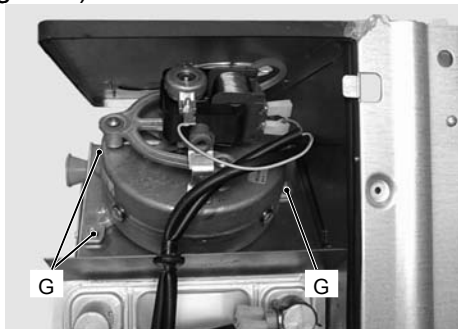

Figure 5

- 4) Unscrew the screws G (Figure 5).
- 5) Remove the fan by sliding it to the right.
- 6) Re-assemble the fan carrying out the removal operations in reverse sequence.

**Warning: Re-assembling the fan ensure that the hooks around the inlet port of the fan hung correctly on the flue hood.**

**Warning: To correctly connect the venturi device to the Air pressure switch, refer to Figure 6.**

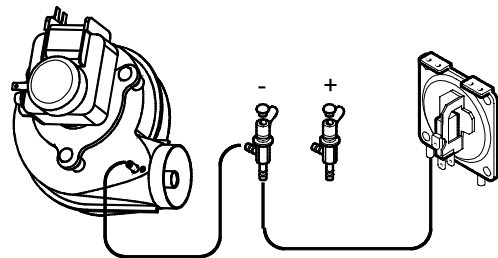

Figure 6

**4 Inspection and Removal of the Venturi Device**

- 1) Remove all the case panels and the sealed chamber lid.
- 2) Remove the fan.
- 3) Remove the venturi device by unscrewing the screw H (Figure 7).

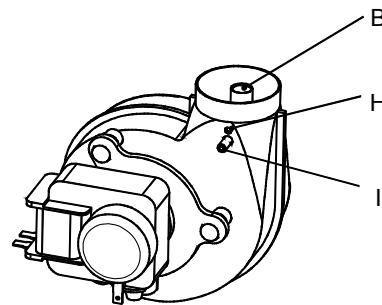

Figure 7

- 4) Inspect the venturi device B and the connection pipe I. Ensure they are clean.
- 5) Re-assemble the parts in reverse order of removal.

**5 Removal of the Air Pressure Switch**

- 1) Remove all the case panels and the sealed chamber lid.
- 2) Disconnect the wires from the Air pressure switch.
- 3) Remove the pipe from the Air pressure switch.
- 4) Unscrew the screws which hold the Air pressure switch to the frame.
- 5) Assemble the Air pressure switch carrying out the removal operations in reverse sequence.

**Warning: To correctly connect the Air pressure switch, refer to Figure 6 and Figure 3 for the correct wiring.**

**Ignition and Detection Electrodes, Burner and Injectors**

- 1) Function
- 2) Checks
- 3) Removal

**1 Function**

Three electrodes are fitted on the burner. Two of them are the ignition electrodes and are fitted near the front part of the burner. The ignition sparks take place between their metallic edges over the central ramp of the burner during the ignition sequence.

The third electrode is the detection electrode and it detects the presence of the flame.

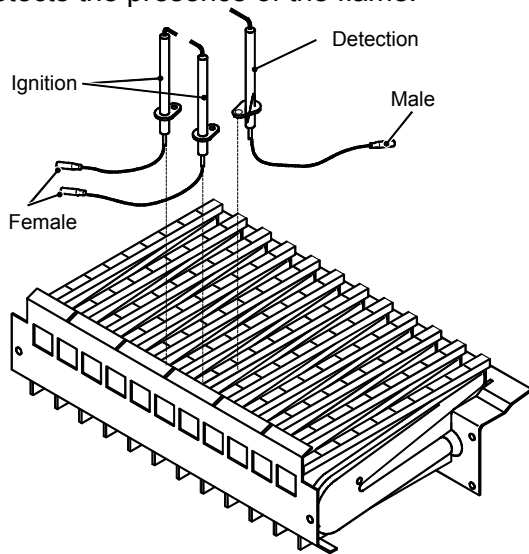

Figure 1

**2 Checks**

**A Check the position of the electrode edges**

**Warning: Isolate the boiler from the mains electricity supply before removing any covering or component.**

- 1) Remove all the case panels, the sealed chamber lid and the combustion chamber lid.
- 2) Check for the correct distance between the metallic edges of the ignition electrodes (see Figure 2).

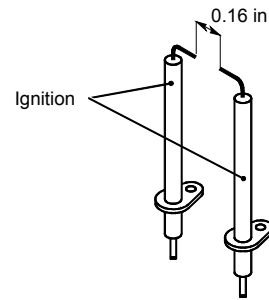

Figure 2

- 3) Check the integrity of the detection electrode and ensure that its metallic edge is correctly placed over the ramp of the burner.

**B Check the connection wires.**

**Warning: Isolate the boiler from the mains electricity supply before removing any covering or component.**

- 1) Remove all the case panels, the sealed chamber lid and the combustion chamber lid.
- 2) Check for the integrity of the insulation of wires which connect the electrodes to the ignition device.

**3 Removal**

- 1) Remove all the case panels, the sealed chamber lid and the combustion chamber lid.
- 2) Disconnect the electrode wires from the full sequence ignition device.
- 3) Remove the burner by unscrewing the four screws placed at the right and left sides of the burner.
- 4) Remove the deflector by unscrewing the screw B (Figure 3).

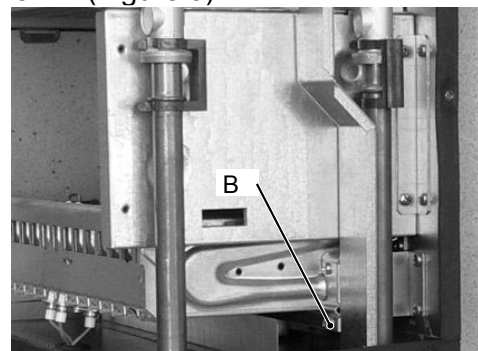

Figure 3

- 5) Unscrew the screws D (Figure 4) which hold the electrodes to the burner.

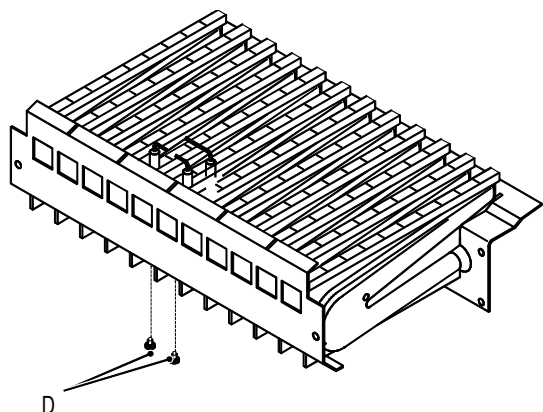

Figure 4

- 6) Extract the electrodes from the burner.
- 7) Re-assemble the parts carrying out the removal operation in reverse order.

**Note: The metallic edge of the detection electrode is longer than the one of the ignition electrodes.**

## Safety Thermostat

- 1) Function
- 2) Checks
- 3) Removal

### 1 Function

The safety thermostat A in Figure 1 is a device that senses the temperature of the primary circuit water which flows in the outlet pipe of the primary heat exchanger.

If the temperature control system of the boiler fails and the temperature of the primary circuit reaches a dangerous temperature, the safety thermostat opens the electric circuit that supplies the on-off operators of the gas valve.

Consequently, the full sequence ignition device attempts to light the burner and, at the end, locks the boiler and lights the lock-out signal lamp.

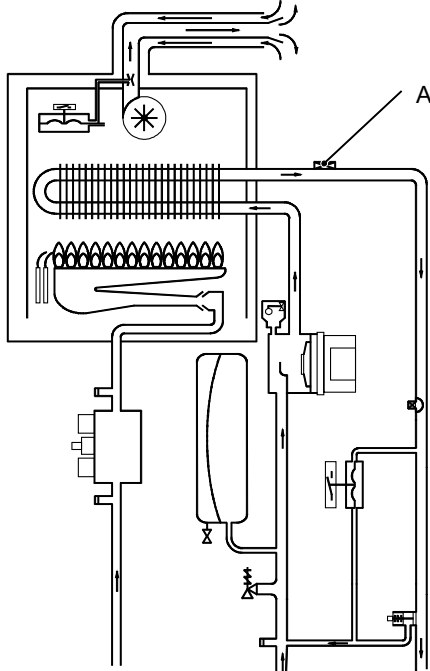

Figure 1

### 2 Checks

#### A Overheat temperature value

- 1) Set the temp. control knob to its maximum position and run the boiler.

- 2) Allow the boiler to reach its maximum operating temperature (monitor the temperature gauge on the instrument panel). The boiler should maintain a temperature below that of the safety thermostat and no overheat intervention should occur.

**Warning: Isolate the boiler from the mains electricity supply before removing any covering or component.**

#### B Electrical function

- 1) Remove all the case panels and the lid of the sealed chamber.
- 2) Disconnect the safety thermostat and check its electrical function. Normally (no intervention) the contact must be closed (electrical resistance zero  $\Omega$ ).

### 3 Removal

**Warning: Isolate the boiler from the mains electricity supply before removing any covering or component.**

- 1) Remove all the case panels and the lid of the sealed chamber.
- 2) Unscrew the three screws B (Figure 2).

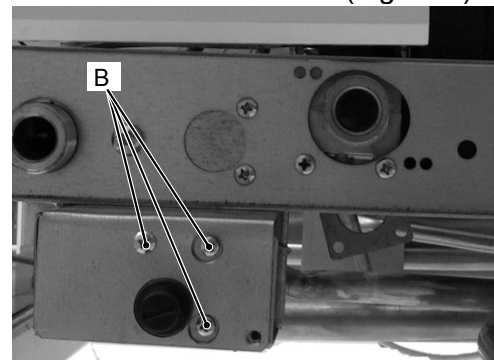

Figure 2

- 3) Disconnect the three connectors of the safety thermostat.
- 4) Remove the probe holder spring C freeing the safety probe D (Figure 3).

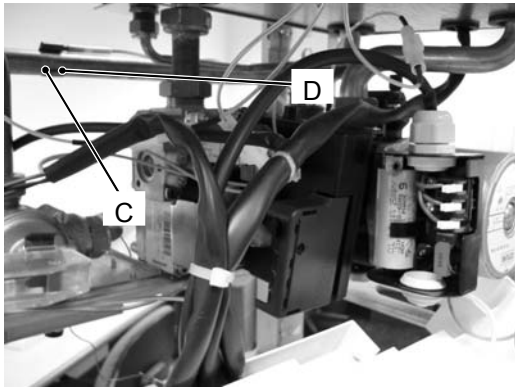

Figure 3

- 5) Re-assemble the parts carrying out the removal operation in reverse order.
- 6) Apply an adequate quantity of heat conducting compound between the pipe and the thermostat.

**Electric Resistances**

- 1) Pump Resistance
- 2) Gas Valve Resistance
- 3) Temperature Probe NTC Resistance
- 4) Fan Resistance

Resume of the electric resistances in  $\Omega$  of the boiler parts.

**1 Pump Resistance**

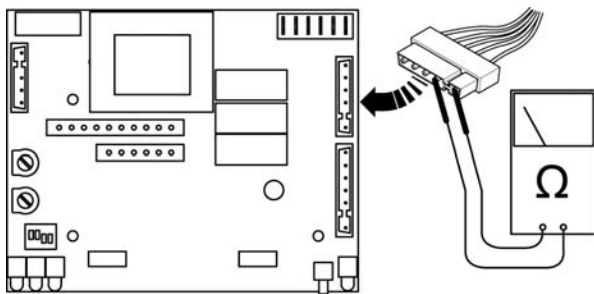

Figure 1

Pump Resistance = 51.7  $\Omega$ .

**2 Gas Valve Resistance**

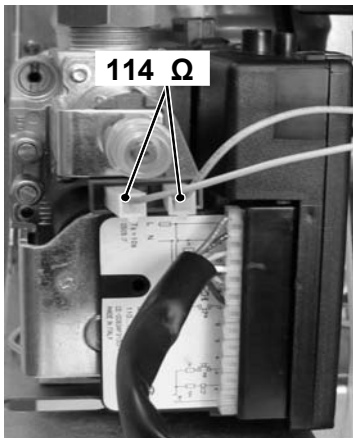

Figure 2

On-off operator  
approx. 1 122  $\Omega$ \*

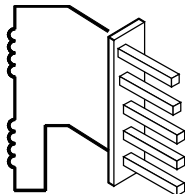

Figure 5

\* at ambient temperature

**3 Temperature Probe NTC Resistance**

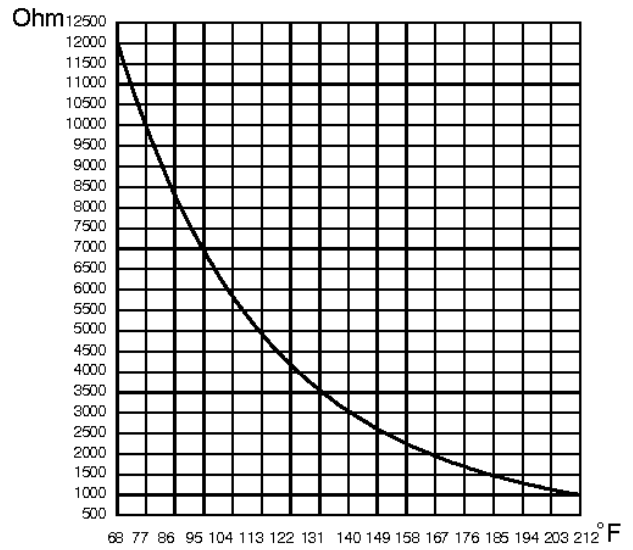

Figure 3

**4 Fan Resistance**

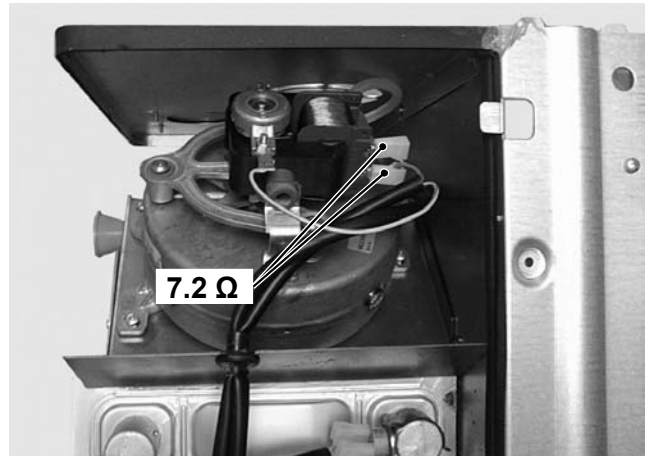

Figure 4

Key	Description	Quantity	Manufacturer Part No.	Manufacturer's Reference
1	Burner	1	BI1203 103	Polidoro
2	Injectors for Natural Gas	14	BI1203 502	Polidoro
	Injectors for L.P.G.	14	BI1203 503	Polidoro
3	Modulation Gas Valve	1	BI1203 104	Honeywell
4	C.h. Expansion Vessel	1	BI1182 105	Zilmet
5	Primary Heat Exchanger	1	BI1242 108	Mgm
6	Fan	1	BI1386 118	Fime
7	Air Pressure Switch	1	BI1386 119	Yamatake
8	Combustion Chamber Front Panel	1	BI1366 109	
9	Combustion Chamber Rear Panel	1	BI1326 108	
10	Combustion Chamber Left Panel	1	BI1326 100	
11	Combustion Chamber Right Panel	1	BI1326 100	
12	Control p.c.b.	1	BI1555 107	Ceza
13	Fan and Air Pressure Dev.	1	BI1555 108	Ceza
14	Full Sequence Ignition Dev.	1	BI1555 109	Honeywell
15	C.h. Pressure Relief Valve	1	BI1191 121	Conbraco Industries
16	Safety Thermostat	1	BI1242 109	Imit
17	Primary Circuit Flow Switch	1	BI1011 505	
18	Pump	1	BI1242 110	Wilo
19	Fuse 4.0A 250V 5x20F	1	BI1555 110	
20	Primary Circuit Temp. Probe	1	BI1001 117	I.T.S.
21	Ignition Electrode (left)	1	BI1203 105	Network Components
22	Ignition Electrode (right)	1	BI1203 106	Network Components
23	Detection Electrode	1	BI1203 107	Network Components
24	Temperature Pressure Gauge	1	BI1555 100	Wika Italiana



