

B10 SERIES BOILER

B3-B9

Boiler Manual And Installation Instructions for Atmospheric Venting

**Please Read Instructions Carefully
Save for Future Reference**

WARNING

If the information in this manual is not followed exactly, a fire or explosion may result causing property damage, personal injury or loss of life.

DANGER

WHAT TO DO IF YOU SMELL GAS

- Do not try to light any appliance
- Do not touch any electric switch; do not use any phone in your building
- Immediately call your gas supplier from a neighbor's phone. Follow the gas supplier's instructions.
- If you can not reach your gas supplier call the fire department

Installation and service must be performed by a qualified installer, service agency or the gas supplier.

Manufactured by:

**Biasi S.p.A.
Verona, Italy**

Distributed By:

QHT

QUINCY HYDRONIC TECHNOLOGIES, INC.

80 ROCHESTER AVE. SUITE #12

PORTSMOUTH, NH 03801

PHONE: 603-334-6400

FAX: 603-334-6401

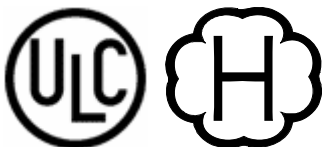

QHT **BIASI**
The New Style of Warmth

Dear Customer:

Thank you for buying a QHT BIASI B10 Series Boiler.

The QHT BIASI B10 Series Boiler is a cast iron, oil or gas fired hot water boiler, using the famous BIASI B10 (3-pass) design. The boiler is light, compact, simple, rugged and engineered for maximum home heating efficiency.

We realize that it is not possible to answer all questions about the VEGA B10-series boiler system in this manual. Reading this installation manual does not make the reader an expert in all aspects of installation and operation, and does not replace the need for a qualified licensed heating contractor. We urge you to contact your installing contractor or distributor if you are in question about any aspect of your boiler's performance. Our main concern is that you are satisfied with your boiler and its performance. We require that your contractor complete efficiency tests using instruments.

The controls and accessories listed in this manual are intended to serve as guidelines rather than specific recommendations. We realize that other makes and models of such devices are available and can be used as successfully as those we specify. The installing contractor is the best judge of a system's specific requirements, as well as the local availability of certain makes and models of controls and accessories. The preceding does not apply, however, to the equipment that comes with every boiler, such as the overheat control (L4006A or 7248U) and pressure relief valve. **The installation of the specific devices supplied with every boiler is absolutely necessary to the safe operation of the boiler and protection of the heating system.**

All BIASI Boiler blocks are built in accordance with the ASME boiler and pressure vessel code, and bear the "H" stamp. The entire range of applications for the QHT BIASI B10 Series Boiler have been tested to CAN/CGA B149 and are ULC compliant.

This BIASI B10 Boiler block has a limited lifetime warranty (refer to back of manual), a copy of which is provided with the boiler. Please be sure to return the warranty registration card as the warranty will be void without your boiler's serial numbers (located on the plate on the leg of the boiler), date of installation and the name of your installer.

Thank you for purchasing our QHT BIASI B10 Series Boiler. If you have questions or comments, please don't hesitate to contact us immediately. Our goal is 100% customer satisfaction.

Sincerely,

Jim Quincy
QHT Inc.

TABLE OF CONTENTS

| QHT BIASI B10 Series | Section | Page |
|--|----------------|------------------|
| Important Information & Warnings | | 4,5,6 |
| General Information | 1 | 7 |
| Boiler Block Assembly & Explosion Diagram | 2 | 8 |
| Boiler Location | 3 | 9 |
| Installation of Boiler Trim Kit Components | 4 | 10,11 |
| Piping the Boiler | 5 | 12 |
| Intake Venting | 6 | 13,14 |
| Exhaust Venting | 7 | 15 |
| Common Exhaust Venting | 7.1 | 15,16 |
| Blocked Flue Switch | 7.2 | 16 |
| Gas Venting | 7.3 | 17 |
| Burner Setup | 8 | 18 |
| Oil | 8.1 | 19 |
| Gas | 8.2 | 20 |
| Gas Line Piping | 9 | 21 |
| Boiler Jacket Assembly | 10 | 22 |
| Wiring | 11 | 23-24 |
| Oil Diagrams | 11.1 | 25-28 |
| Gas Diagrams | 11.2 | 29-30 |
| Commissioning the Boiler | 12 | 31 |
| Maintenance | 13 | 31 |
| Installer Notes | 14 | 32 |
| Warranty | | Inside Backcover |

This installation manual is for the basic installation of a B10 series boiler for atmospheric venting of oil and gas. If you are installing a direct vent system, please refer to its addendum to be used in conjunction with this manual to insure the proper installation of the boiler system.

IMPORTANT INFORMATION
Please read this page carefully.

- **ALL BOILERS MUST BE INSTALLED IN ACCORDANCE WITH NATIONAL, STATE AND LOCAL PLUMBING, HEATING AND ELECTRICAL CODES AND ORDINANCES, AS WELL AS THE REGULATIONS OF THE SERVING ELECTRICAL, WATER AND GAS UTILITIES.**
- **All systems should be designed by competent contractors, and only persons knowledgeable in the layout and installation of heating systems should attempt the installation of any boiler. It is the responsibility of the installing contractor to see that all controls are correctly installed and operating properly when the installation is completed.**
- **Do not burn volatile garbage, gasoline, naphtha or other flammable liquids other than No. 2 fuel oil. All flammable liquids (especially gasoline), chemicals, rags, paper, wood scraps, debris, etc., should be kept away from the boiler at all times. Keep the boiler area clean and free of all fire hazards.**
- **Please read the literature and warranties supplied by the manufacturers of the various accessory equipment. This equipment is warranted by the respective manufacturers, not by Quincy Hydronic Technologies, Inc. Each piece of equipment must be installed and used according to the recommendations of the manufacturer.**

Codes and Regulations:

Installation of the boiler, burner, oil tank and related equipment must conform to national, state and local regulating agencies and codes applicable to the installation of the equipment. In the absence of local requirements, the following codes apply:

- | | | | |
|----|---------|-----------|---------------------------------------|
| A. | NFPA | - #31 | Installation of Oil Burning Equipment |
| B. | NFPA | - #70 | National Electric Code |
| C. | NFPA | - #211 | Chimneys and Vents |
| D. | ANSI | - #Z223.1 | National Fuel Gas Code |
| E. | ANSI | - | Domestic Gas Conversion Burner |
| F. | CAN/CGA | - B149 | Installation Codes |
| G. | ANSI | - CSD-1 | |
| H. | CSA | -C22.1 | Canadian Electrical Code, Part1 |

The above codes are available from:

National Fire Protection Association (NFPA)
Battery March Park
Quincy, MA 02269
<http://www.nfpa.org>

CSA International
8501 East Pleasant Valley Road
Cleveland, OH 44134
<http://www.csa-international.org>

WARNING

Any appliance that burns natural gas, propane gas, fuel oil, or coal is capable of producing carbon monoxide (CO). Carbon Monoxide (CO) is a gas which is odorless, colorless and tasteless but is very toxic. CO is lighter than air and thus may travel throughout the building.

BRIEF EXPOSURE TO HIGH CONCENTRATIONS OF CO, OR PROLONGED EXPOSURE TO LESSER AMOUNTS OF CO MAY RESULT IN CARBON MONOXIDE POISONING. EXPOSURE CAN BE FATAL AND EXPOSURE TO HIGH CONCENTRATIONS MAY RESULT IN THE SUDDEN ONSET OF SYMPTOMS INCLUDING UNCONSCIOUSNESS.

Symptoms of CO poisoning include the following:

| | | |
|-----------|------------------------|---------------------|
| dizziness | vision problems | shortness of breath |
| headache | loss of muscle control | unclear thinking |
| nausea | weakness | unconsciousness |

The symptoms of CO poisoning are often confused with those of influenza, and the highest incidence of poisoning occurs at the onset of cold weather or during flu season. A victim may not experience any symptoms, only one symptom, or a few symptoms. **Suspect the presence of carbon monoxide if symptoms tend to disappear when you leave your home.**

The following signs may indicate the presence of carbon monoxide:

- Hot gasses from appliance, venting system pipes or chimney, escaping into the living space.
- Flames coming out around the appliance.
- Yellow colored flames in the appliance.
- Stale or smelly air.
- The presence of soot or carbon in or around the appliance.
- Very high unexplained humidity inside the building.

IF ANY OF THE SYMPTOMS OCCUR, OR IF ANY OF THE SIGNS OF CARBON MONOXIDE ARE PRESENT, VACATE THE PREMISES IMMEDIATELY AND CONTACT A QUALIFIED HEATING SERVICE COMPANY, THE GAS COMPANY OR THE FIRE DEPARTMENT.

ONLY QUALIFIED, LICENSED SERVICE CONTRACTORS SHOULD PERFORM WORK ON YOUR B-10 BOILER.

Homeowner Information for Gas

TO START UP THE APPLIANCE

1. STOP! Read the safety information on the side of the boiler. DO NOT START THE BOILER UNLESS ALL CLEANOUT DOORS ARE SECURED AND SEALED. (Skip to step 9 for oil burning boilers)
2. Set thermostat to lowest setting
3. Turn off all electric power to the appliance
4. Do not attempt to light the burner by hand
5. Turn the manual shut off on the combination gas valve clockwise to the off position.
6. Wait five minutes to clear out any gas. Then smell for gas, including near the floor. **If you smell gas, STOP!**
 - Do not try to light any appliance
 - Do not touch any electric switch; do not use any phone in your building
 - Immediately call your gas supplier from a neighbor's phone. Follow the gas supplier's instructions.
 - If you can not reach your gas supplier call the fire department
7. If you don't smell gas, go to the next step.
8. Return the manual valve on the combination gas valve to the on position by reversing step "5".
9. Turn on all electric power to the appliance.
10. Set thermostat to the desired setting.
11. If the burner fails to light you may press the reset button once. If the appliance will not operate, follow the instructions "To Turn Off Gas To Appliance" and call your service technician or gas supplier. DO NOT ATTEMPT TO START THE BURNER WHEN EXCESS GAS HAS ACCUMULATED, WHEN THE UNIT IS FULL OF VAPOR, OR WHEN THE COMBUSTION CHAMBER IS VERY HOT.

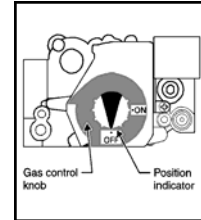

NOTE: ALWAYS KEEP THE MANUAL FUEL SUPPLY VALVE SHUT OFF IF THE BURNER IS SHUT DOWN FOR AN EXTENDED PERIOD OF TIME.

TO TURN OFF GAS APPLIANCE

1. Set the thermostat to the lowest setting.
2. Turn off electric power to the appliance if service is to be performed.
3. Turn the gas control valve to the off position.

1. General Information

The BIASI B 10-series boilers are wet base design, sectional, cast-iron boilers for forced hot water heating systems. The boilers are shipped pre-assembled from the factory in lengths from three to nine sections. They are designed for firing with oil or gas power burners, which are packed separately along with the jacket and controls for shipping purposes.

When the boiler is received, check the contents to ensure that there is no shortage or damage to any part of the boiler system. With every boiler you should receive a boiler block, jacket, trim kit and a burner (oil or gas).

Trim Kit Components

- | | |
|--|--|
| 1 - Honeywell L4006A or 7248U aquastat | 2 - 3/4" Plugs |
| 1 - Immersion well | 1 - 1/4" X 1/2" Bushing |
| 1 - 3/4" X 3" Nipple | 1 - 3/4" 90° Elbow |
| 1 - Combo pressure/temp gauge | 1 - Double acting barometric damper with manual reset spill switch |
| 1 - 30 PSI Pressure relief valve | (Gas systems only) |
| 1 - 3/4" Boiler drain | |
| 1 - Cera-fiber Pad for floor of combustion chamber | |

USE ONLY THE UL LISTED BOILER COMPONENTS AND UL/CSA LISTED OIL OR GAS BURNER COMPONENTS SUPPLIED WITH THE VEGA B10 BOILER SYSTEM.

| Boiler Model | Heating Capacity | Gross Input Burner Capacity | | Net Output | | Flue Gas Resistance | Efficiency | Water Content | Length (L) | Weight |
|---------------------------------------|------------------|-----------------------------|----------|------------|---|---------------------|------------|---------------|------------|--------|
| | | MBH | GPH- Oil | MBH- Gas | OIL | | | | | |
| B-13 | 67 | 0.55 | 80 | 58 | 60 | 0.03 | 86.6 | 3.5 | 15.5 | 249 |
| B-14 | 110 | 0.90 | 115 | 96 | 84 | 0.04 | 85.8 | 4.7 | 19.5 | 308 |
| B-15 | 124 | 1.00 | 140 | 108 | 103 | 0.06 | 87.2 | 5.7 | 23.5 | 367 |
| B-16 | 153 | 1.25 | 175 | 133 | 129 | 0.07 | 86.7 | 6.7 | 28.5 | 427 |
| B-17 | 185 | 1.50 | 215 | 161 | 157 | 0.08 | 86.8 | 7.7 | 33.5 | 486 |
| B-18 | 211 | 1.80 | 257 | 183 | 189 | 0.1 | 86.8 | 8.8 | 38.5 | 546 |
| B-19 | 257 | 2.10 | 298 | 223 | 219 | 0.12 | 86.5 | 9.9 | 42.5 | 606 |
| Maximum Water Working Pressure 58 psi | | | | | Maximum Relief Valve is 30 psi at 500 MBH | | | | | |

All dimensions are in inches.

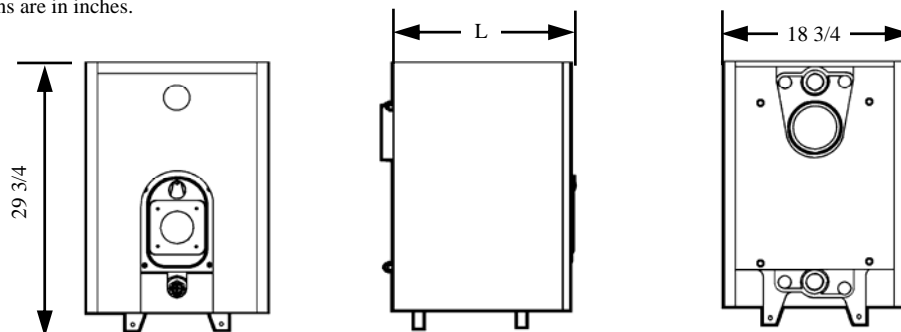

2. Boiler Block Assembly

All QHT BIASI B10 Series Boilers are shipped from the factory in assembled boiler blocks. If, however, the block needs to be split into sections for ease of delivery, please read the following:

To assemble split blocks, move sections into parallel and facing each other. Sections may be slid along boards placed underneath the sections. Inspect nipple ports for damage or burrs. Remove any burrs by scraping the port very lightly. Wipe the push nipples and nipple ports with a clean cloth. Apply a film of nipple compound to both the nipple and port. Install the nipple in the port and then seal by hitting with a hammer cushioned with a block of wood. Apply section sealant to one section only and slide sections together. Install the four draw rods and draw the sections together evenly (measure with yardstick). Draw the sections together until sections make iron-to-iron contact at a point around the top and bottom ports of each section.

DO NOT OVER TIGHTEN DRAW RODS

NOTE: When cutting off excess length of draw rods, allow enough length to install boiler jacket on the draw rods.

Boiler Components & Parts

BIASI B - Series

Boiler Block Assembly:

- 1 Front Section
- 2 Rear Section
- 3 Intermediate Section
- 4 Steel Push Nipples
- 5 Tie Rod
- 6 Tie Rod Nut
- 7 Tie Rod Washer
- 8 1 1/2" X 3/4" Bushing
- 9 Plug gasket
- 10 1/2" X 1 1/2" Bushing
- 11 Boiler Swing Door
- 12 Front Door Upper Insulation
- 13 Front Door Upper Gasket
- 14 Front Door Upper Plate
- 15 Front Door Lower Insulation
- 16 Front Door Stud (Qty 7)
- 17 Front Door Lower Gasket
- 18 3/4" Plug (Sight Hole)
- 19 Boiler Door Hinge (4 pieces)
- 20 Hinge Pin (Qty 6)
- 21 Boiler Body Hinge Bolts (Qty 2)
- 22 Door Hinge Mounting Bolts (Qty 2)
- 23 6 inch Boiler Breeching
- 24 Upper Front Fixed Door

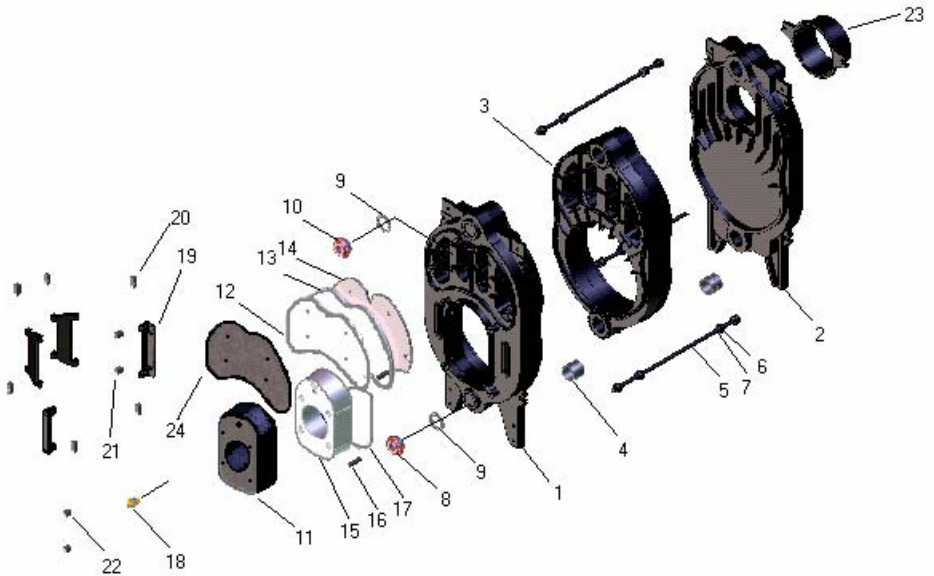

3. Boiler Location

The following are the minimum clearance to construction or combustible materials:

1. 9" from the top, sides, and rear of the boiler.
2. 18" from the flue pipe in any direction.
3. 24" from the front of the boiler.

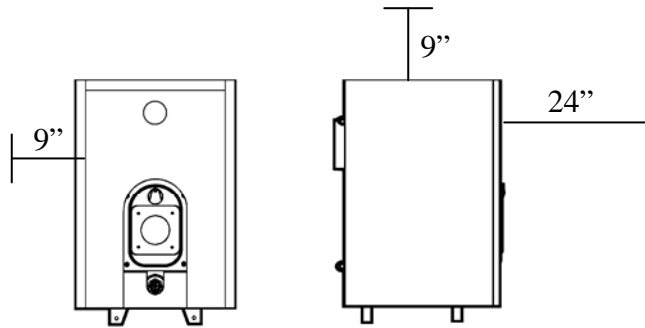

DANGER

The boiler must be located on a non-combustible floor. A smooth, level concrete floor is recommended. Locate the boiler as close as possible to the chimney. If boiler is installed on combustible flooring, consult local authorities for proper method of covering floor. The boiler must not be installed on carpeting.

Caution: Do not store or use flammable materials, chemicals or flammable liquids, especially gasoline, in the vicinity of this heating appliance.

If the boiler is to be installed in a "direct vent" configuration, please refer to the B10 Direct Vent Addendum supplied with the Direct Vent Kit.

PROVISIONS FOR COMBUSTION AIR AND VENTILATION AIR MUST BE IN ACCORDANCE WITH SECTION 5.3, "AIR FOR COMBUSTION AND VENTILATION", OF THE NATIONAL FUEL GAS CODE, ANSI Z223.1, OR APPLICABLE PROVISIONS OF THE LOCAL BUILDING CODES. **DO NOT INSTALL THE BOILER UNTIL PROPER COMBUSTION AIR HAS BEEN ARRANGED.**

WARNING

Boiler is certified as an indoor appliance. Do not install boiler outdoors or locate where it will be exposed to freezing temperatures

4. Installation of Boiler Trim Components

Trim Kit Components

- | | |
|--|--|
| 1 - Honeywell L4006A or 7248U aquastat | 1 - ¼" X ½" Bushing |
| 1 - Combo pressure/temp gauge | 2 - ¾" Plugs |
| 1 - ¾" X 3" Nipple | 1 - ¾" 90° Elbow |
| 1 - 30 PSI pressure relief valve | 1 - Immersion well |
| 1 - ¾" Boiler drain | 1 - Double acting barometric damper with manual reset spill switch (Gas systems only) |
| 1 - Cera-fiber Pad for floor of combustion chamber | |

USE ONLY THE ULC LISTED BOILER COMPONENTS AND UL/CSA LISTED OIL OR GAS BURNER COMPONENTS SUPPLIED WITH THE QHT BIASI B10 SERIES BOILER SYSTEM.

Please refer to figures below for Barometric Damper location for either oil or gas and to the next page for the proper location of the trim components.

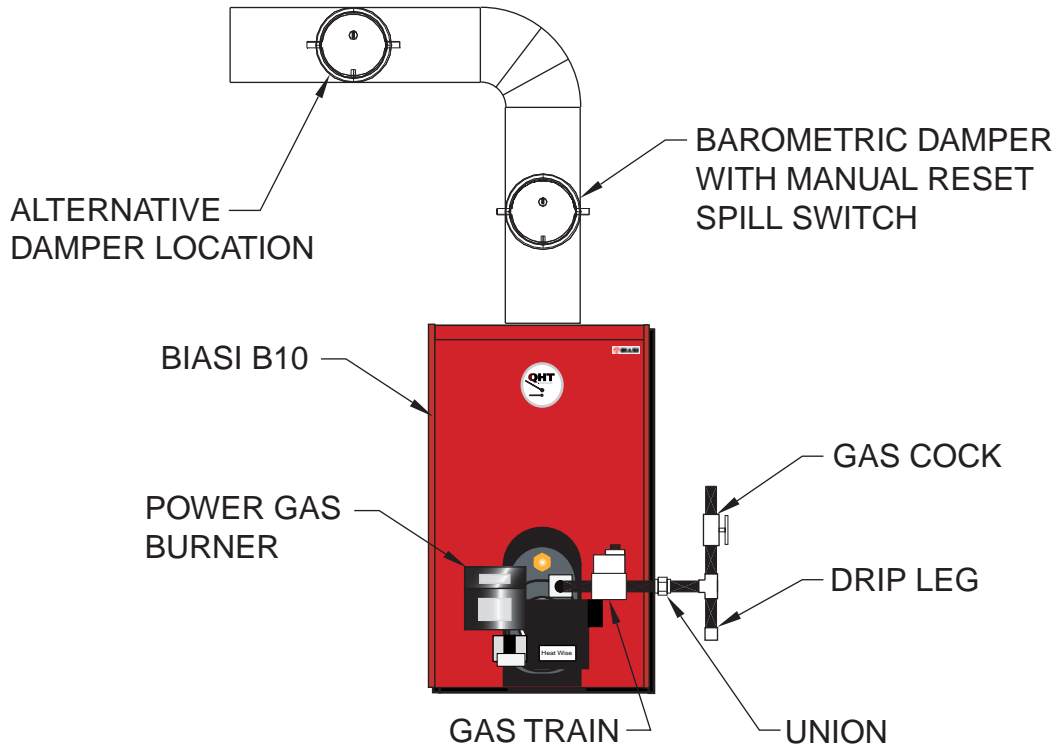

NOTE: See Page 19 for available gas burners in North America

4. Installation of Boiler Trim Components Cont.

1. Install L4006A aquastat in upper left or right rear tapping using 3/4" immersion well. All tapings and joints should be sealed with piping compound. The L4006A can be adjusted up to 220° F, and should be set to the desired temperature by the installer. The differential is also adjustable between 5 and 30 degrees. It should be set as close to 30 degrees as possible to prevent short cycling of the boiler. If you are installing a 7248U, Screw the unit to side panel of the boiler as close to the immersion well as possible using the tabs on the aquastat. Run the sensor from behind the aquastat to the immersion well and fix it according to Honeywell's instructions. The 7248 can be adjusted between 140° F and 220° F with a fixed differential of 30 degrees.
2. Install Pressure Relief Valve in opposite, upper rear tapping using 3" nipple and 3/4" elbow
3. Install 3/4" boiler drain in lower left or right rear tapping, or lower front tapping.
4. install 3/4" plug in opposite lower rear tapping, and/or the other plug in lower front tapping of the boiler.
5. Install combination pressure/temperature gauge and 1/2" x 1/4" bushing in upper front tapping. **The gauge must be tightened using a wrench and not your hand.**
6. Install burner mounting hardware in the four tapings on the front of the boiler door.
7. Install boiler door bolts on opposite side of door hinge.

Boiler Tapping Diagram:

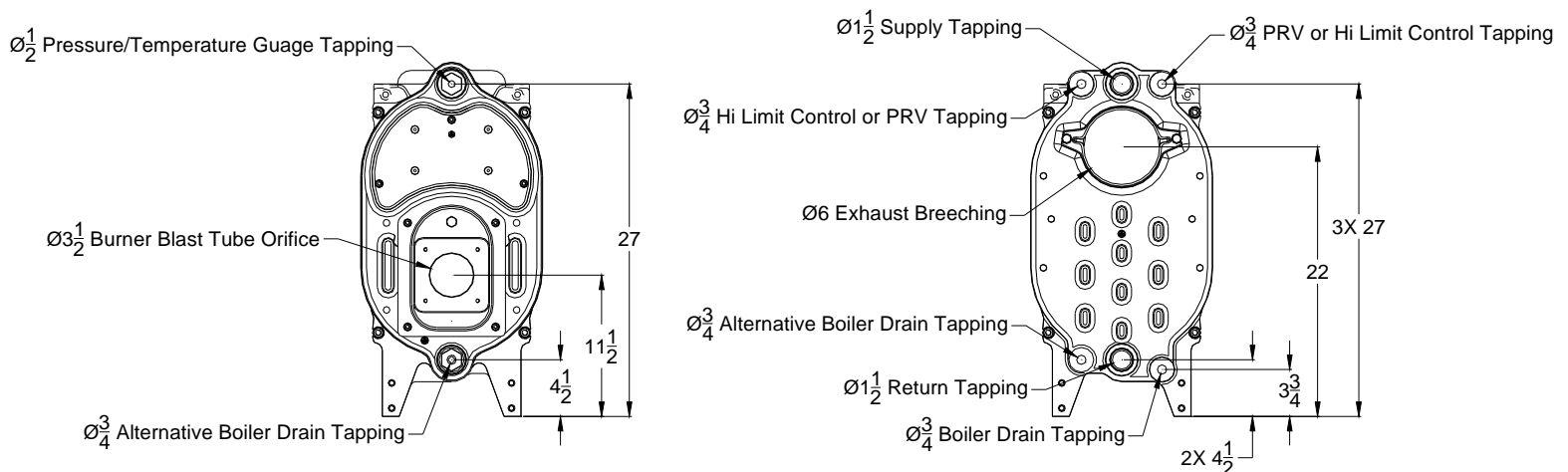

5. Piping the Boiler

All piping must conform to state and local codes. Page 11 shows the location and size of the boiler tapings. It is recommended to install unions and gate valves at the inlet and outlet of the boiler, so it may be readily isolated for service.

For **Canadian** installations, a low water cut off is required if the boiler is installed above the level of radiation. Even if the boiler is installed below the level of radiation it is strongly recommended that a low water cut off be installed. Install manual and/or automatic air venting devices at the high points in the system to eliminate trapped air. The weight of all piping should be supported by suitable hangars and floor stands, not by the boiler's purging/expansion station. Clearance for hot water pipes are 1 inch to combustibles. **The make-up water line must be piped into the boiler and be fitted with a backflow preventer and a pressure-reducing valve to reduce line pressure to 10 to 15 psi.**

In the case of a gas installation, the boiler should be installed such that the gas ignition system components are protected from water (dripping, spraying, etc.) during appliance operation and service (circulator replacement, condensate trap, control replacement, etc.).

If the boiler is to be used in conjunction with a chilled water system, it must be piped with the appropriate valves to ensure the chilled medium does not enter the boiler. If the boiler is connected to heating coils in an air handling system, where the coils could be exposed to cold air circulation, provisions for freeze protection control must be installed. The boiler must have flow control valves or other automatic means to prevent gravity circulation of the boiler water during the cooling cycle.

NOTE: If the heating system is to be filled with antifreeze, use only formulations expressly made for hydronic heating systems (such as propylene glycol). **Do not use automotive types of antifreeze (ethylene glycol).** Use of antifreeze will alter system output and characteristics. Consult a factory representative for details or assistance.

SAFETY RELIEF VALVE

1. The safety relief valve should be piped into one of the two upper tapings in the rear of the boiler
2. The relief valve should be installed using the hardware supplied in the trim kit without valving between the PRV and the boiler.
3. Pipe the discharge for the safety relief valve with copper tube to within four inches from the floor to prevent injury in the event of a pressure release. Provide piping that is the same size as the safety relief valve outlet.

6. Intake Venting

1. Be certain adequate air is available for combustion and ventilation.

a.) Boiler located in unconfined space:

Installation in large areas, such as basements, can usually be assumed to provide sufficient air.

b.) Boiler located in confined space : (See Figure A.)

If all air for combustion and ventilation is to come from within the building:

Two (2) openings shall be provided with one (1) opening commencing within 12 inches of the ceiling and one (1) opening commencing within 12 inches of the floor of the enclosure. These openings shall not be located closer than 3 inches from either the top or bottom of the enclosure and shall be open to areas connecting freely with the outdoors. The area of each opening shall not be less than one square inch per 1000 BTU/HR. of total input rating of all appliances within the enclosure; with a minimum of 100 square inches for each opening.

If all the air for combustion and ventilation is to come from outside the

building: Two (2) openings shall be provided with one opening commencing within 12 inches of the top and an opening commencing within 12 inches of the bottom of the enclosure. These openings shall not be located closer than 3 inches from either the top or bottom of the enclosure, and shall connect directly or by ducts with the outdoors. The area of each opening shall be equal to one square inch per 4000 BTU/HR of total input rating. If ducts are used to convey the air, vertical ducts require areas of one square inch per 4000 BTU/hr. Horizontal ducts require one square inch per 2000 BTU/hr. Ducts shall have the same cross sectional area as the full area of the louver openings.

The upper opening is essential for maintenance of proper air circulation with the boiler and of reasonable ambient temperature to maintain proper control temperatures. When a duct is used for ventilation, check for louver free net area and correct for screen resistance to ensure that the sufficient ventilation area has been satisfied. **DO NOT INSTALL THE BOILER UNTIL PROPER COMBUSTION AIR HAS BEEN ARRANGED.**

6. Intake Venting Cont.

c.) Boiler located in a room under negative pressure:

If the boiler is to be installed within a home where the operation of exhaust fans, attic fans, kitchen ventilation systems, clothes dryers or fireplaces may create severe negative vent pressures causing unsatisfactory combustion and venting, special provisions should be made for additional make-up air to supply the other air requirements. If building is of tight construction, combustion air requirements may not be met and combustion air ducts from outside may be necessary. Please refer to NFPA No. 31.

Tight Construction (as defined by ANSI Z223.1):

1. Walls and ceilings exposed to the outside atmosphere have a continuous water vapor retarder with a rating of 1 perm or less with openings sealed with gaskets, etc..
2. Weather-stripping has been added on open able windows and doors, and caulking or sealants are applied to areas such as: joints around windows and door frames, between sole plates and floors, between wall-ceiling joints, between wall panels, at penetrations for plumbing, electrical, and gas lines, and in other openings.

If the building is of tight construction, air openings must be provided from the outside, with appropriate sizing depending on amount of BTU/H as shown in pictures. The boiler room must never be under a negative pressure, even if the appliance is installed as direct vent. Always provide air openings sized not only to the dimensions required for the firing rate of all appliances, but also to handle the air movement rate of the exhaust fans or air movers using air from the building or boiler room.

Figure A.

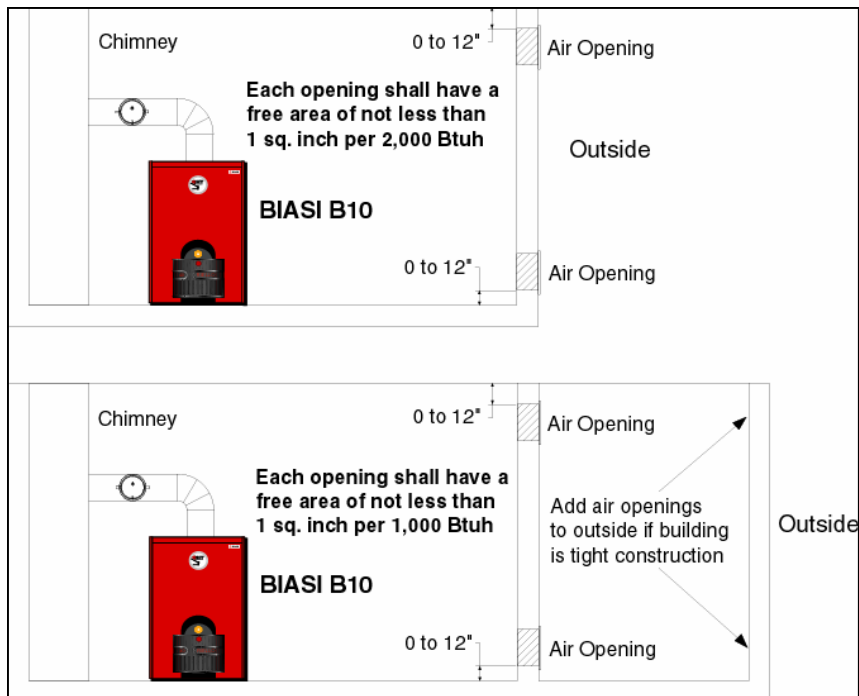

7. Exhaust Venting

The B10 boiler is a high efficiency unit that requires proper venting. The boiler must be vented to the outdoors by means of a tile lined masonry or a approved pre-fabricated chimney of the size and height recommended by the manufacturer or by a listed "power venting" unit which provides draft by mechanical means. In many installations, particularly older interior and most exterior chimneys, a corrosion resistant liner should be installed and may be required by code. Please consult liner manufacturer for the appropriate chimney liner.

The chimney discharge opening must be located at least 24 inches above any part of the building structure within 4 feet of the chimney. Be sure the chimney and smoke pipe won't become obstructed by squirrels, bird nests, soot buildup, chimney liner deterioration, etc.. If using a "power venter" system, it is suggested that it should be installed on the leeward side of the house. (Please consult with manufacturer of "power venter" for requirements concerning clearances from combustibles and distances from doors and windows.) The "venter" must be installed by a licensed burner mechanic and done in accordance with local codes. This is a very low stack temperature boiler (350F gross temp.) so caution should be used when connecting to an outside built chimney. Should you have concern that the flue gases could condense, then you should consider lining the chimney or using a listed, "power venting" or "direct venting unit". If "power venting" is used to discharge flue gases, then the power vent unit should be equipped with a postpurge control such as a delay-off, timing control to prevent problems with fogging and nozzle post drip.

The exhaust pipe connection from the boiler to the chimney should be as short as possible, with a minimum number of elbows. The vent pipe must have a vertical rise of at least 1/4 inch per foot of horizontal run. The vent pipe must be of the same diameter as the flue outlet on the boiler. The chimney connector should have a minimum thickness of 26 gauge, corrosion resistant (galvanized) steel, and be assembled with a minimum of three (3) sheet-metal screws in each joint. In some one and two story houses, a barometric draft control isn't required as the B-10 is designed to be pressure-fired. However in high draft situations which exceed the flue gas resistance through the boiler, a barometric draft control is recommended. The over fire draft should be positive and between 0 and .06 inches of water column. The draft at the breech should be enough to overcome the resistance through the boiler.

7.1 Common Exhaust Venting Cont.

Common vent exhaust:

If this boiler is replacing one that was part of a common venting system, it is likely that the vent is too large to vent the appliances still attached to it. To prevent this, at the time of removal, the following steps shall be followed with each appliance remaining connected to the common venting system. Place each appliance in operation, while the other appliances remaining connected to the common venting system are not in operation.

1. Seal any unused openings in the common venting system.
2. Visually inspect the venting system for proper size and horizontal pitch and determine there is no blockage or restriction, leakage, corrosion and other deficiencies which could cause an unsafe condition.

7.1 Common Exhaust Venting Cont.

3. Insofar as practical, close all building doors and windows and all doors between the space in which the appliance remaining connected to the common venting system is located and other spaces of the building . Turn on any appliance not connected to the common vent system. Turn on all exhaust fans except for summer exhaust fans. Close the fireplace damper if applicable.
4. Place in operation the appliance being inspected. Follow the lighting instructions. Adjust thermostat so appliance will operate continuously.
5. Test for spillage at the barometric damper opening after 5 minutes of main burner operation. Use the flame of a match or candle, or smoke from a cigarette, cigar or pipe.
6. After it has been determined that each appliance remaining connected to the common venting system properly vents when tested as outlined above, return the doors, windows, exhaust fans, fireplace dampers and any other gas-burning appliance to their previous condition of use.
7. Any improper operation of the common venting system should be corrected so the installation conforms with the National fuel Gas Code, ANSI Z223.1 and/or CAN/CGA B149, Installation Codes. When resizing any portion of the common venting system, the common venting system should be resized to approach the minimum size as determined using the appropriate tables in Part 11 of the National Fuel Gas Code, ANSI Z223.1, and/or CAN/CGA B149, Installation Codes.

7.2 Blocked Flue Switch:

1. Pierce a 5/8" hole into the vent pipe near the appliance outlet. Remove one of the securing nuts from the pipe of the safety switch. Tighten the other securing nut onto the pipe as far as possible.
2. Insert the threaded pipe end into the pierced hole, then install the securing nut, then install the securing nut, which was removed in step 1, and tighten securely.
3. Please consult the wiring section of this manual for the wiring of the blocked flue switch.

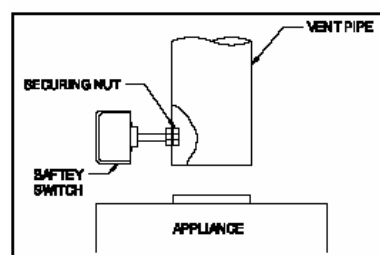
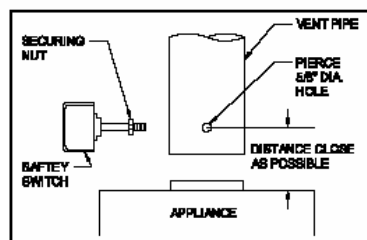

7.3 Gas Venting

For boilers connected to gas vents or chimneys, vent installations shall be in accordance with part 7, Venting of Equipment, of the National Fuel Gas Code, ANSI Z223.1 or Section 7, Venting Systems and Air Supply for Appliances, of the CAN/CGA B149, Installation Codes, or applicable provisions of the local building codes.

Vent connectors serving appliances vented by natural draft shall not be connected into any portion of mechanical draft systems operating under positive pressure.

8. Burner Setup

Good, reliable operation with a minimum of service, starts with attention to the small details:

Oil:

1. Setting the nozzle position and electrodes "by the book" using the manufacturer's gauges.
2. Installing a quality micron filter at the burner.
3. Making careful/tight flare connections, without couplings, on oil suction line.
4. Checking fuel pump pressure.
5. Checking draft at the breeching to insure it is adequate to overcome flue gas resistance. (-.02 to -.04 in. w.c.)
6. Setting the air band properly with well maintained instruments. A good target is 11% to 12.5% of (CO_2) or 6.5% to 3.8% of (O_2).

To ensure proper burner setup, gauges should be used to check things such as the pump pressure, CO_2 levels, etc...

Gas:

1. Checking the electrode, orifice size, and flame rod settings against manufacturer's specs to insure proper operation.
2. Installing properly sized gas piping according to BTU input required and length of gas line run.
3. **Making sure there is proper manifold pressure before and after the gas valve using a calibrated manometer.**
4. Checking draft at the breeching to insure it is adequate to overcome flue gas resistance. (-.02 to -.04 in. w.c.)
5. Setting the air band properly with well maintained instruments. A good target is 9.5% to 10.5% of (CO_2) or 5% to 2.5% of (O_2) for natural gas, or 10.0% to 12.0% of (CO_2) or 5% to 2.5% of (O_2) for LP gas.

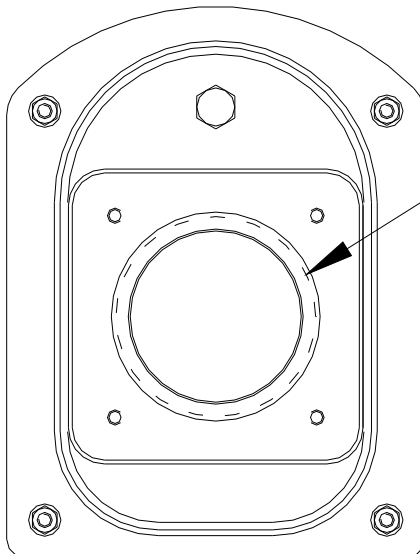

TRIM INSULATION IN
BOILER DOOR OPENING
TO 4.25" FOR BECKETT AFG
BLAST TUBE.

8.1 Oil Burner Setup

This page is only for boilers using an oil burner. If a gas burner is being used, please refer to page 19 for the proper setup of the burner and gas lines.

| BURNER MANUFACTURER: Beckett NX | | | | |
|---------------------------------|-----------|-----------|-----------|-----------|
| Boiler Model | B-3 | B-4 | B-5 | B-6 |
| Burner Model | NEC-1102* | NEC-1101* | NEC-1101* | NEC-1103* |
| Firing Rate | 0.55 | 0.90 | 1.00 | 1.20 |
| Insertion Depth | 3.50" | 6.00" | 6.00" | 6.00" |
| Nozzle | 0.50 X 60 | 0.65 X 60 | 0.75 X 60 | 0.90 X 60 |
| Spray Pattern | hollow | solid | solid | W |
| Pump Pressure | 180 psi | 180 psi | 180 psi | 180 psi |
| Head Type | NX70LC | NX90LB | NX90LB | NX90LB |
| Head Position | 0.75 | 2.75 | 3.75 | 3.75 |

| BURNER MANUFACTURER: Beckett AFI | | | | |
|----------------------------------|-----------|-----------|-----------|-----------|
| Boiler Model | B-4 | B-5 | B-6 | B-7 |
| Burner Model | NEC-301* | NEC-302* | NEC-303* | NEC-303* |
| Firing Rate | 0.8 | 1 | 1.25 | 1.5 |
| Insertion Depth | 2.75" | 2.75" | 2.75" | 2.75" |
| Nozzle | 0.65 X 60 | 0.85 X 60 | 1.00 X 60 | 1.10 X 60 |
| Spray Pattern | hollow | solid | solid | Solid |
| Pump Pressure | 160 psi | 140 psi | 160 psi | 185 psi |
| Head Type | 6 slot | 6 slot | 9 slot | 9 slot |
| Head Position | 3 | 4 | 5 | 6 |

*The highlighted burners are not listed by ULC and may not be installed on Biasi equipment in Canada.

| BURNER MANUFACTURER: Beckett AFG | | | | | |
|----------------------------------|-----------|-----------|-----------|-----------|--------------|
| Boiler Model | B-3 | B-4 | B-5 | B-6 | B-7 |
| Burner Model | NEC 1301 | NEC 1302 | NEC 1303 | NEC 1304 | NEC 1304 |
| Firing Rate | 0.55 | 0.80 | 1.00 | 1.25 | 1.50 |
| Insertion Depth | 2.75" | 2.75" | 6.0" | 3.5" | 3.5" |
| Nozzle | 0.50 x 60 | 0.75 X 60 | 0.75 X 60 | 1.10 X 60 | 1.35 X 60 |
| Spray Pattern | Solid | Solid | Solid | Solid | Solid |
| Pump Pressure | 180 psi | 150 psi | 175 psi | 125 psi | 125 psi |
| Head Type | L1 | L1 | V1 | V1 | V1/2 Setting |
| Air Shutter | 8.0 | 10.0 | 7.0 | 10.0 | 10.0 |
| Air Band | 0.0 | 0.0 | 0.0 | 1.0 | 3.0 |

| BURNER MANUFACTURER Heat Wise | | | | | | | |
|-------------------------------|-----------------------|-----------|------------|-----------|-----------|----------|-----------|
| Pioneer | | | | | | | |
| Boiler Model | B-3 | B-4 | B-5 | B-6 | B-7 | B-8 | B-9 |
| Burner Model | P-1 FV ₍₁₎ | P-1 KA | P-1 KA | P-2 KA | P-2KA | P-2KA | P-2KA |
| Firing Rate | 0.55 | 0.90 | 1.00 | 1.25 | 1.50 | 1.8 | 2.1 |
| Nozzle | 0.40 X 80 | 0.65 X 70 | 0.85 X 70 | 1.00 X 80 | 1.25 X 80 | 1.5 X 80 | 1.75 X 70 |
| Spray Pattern | Solid | Solid | Semi Solid | Hollow | Hollow | Hollow | Solid |
| Pump Pressure | 190 | 190 | 140 | 155 | 145 | 145 | 140 |
| Head Setting | 1 | 1 | 1 | 3.75 | 6 | 10.75 | 14.25 |
| Air Setting | 0 | 9.5 | 16.5 | 6 | 11 | 6 | 11 |
| 1) 120-mm Fan Needed | | | | | | | |

| BURNER MANUFACTURER Riello F-40 Series | | | | | | | |
|--|-----------|-----------|-----------|-----------|-----------|-----------|-----------|
| Boiler Model | B-3 | B-4 | B-5 | B-6 | B-7 | B-8 | B-9 |
| Burner Model | F-3 | F-3 | F-5 | F-5 | F-5 | F-10 | F-10 |
| Firing Rate | 0.55 | 0.80 | 1.00 | 1.25 | 1.50 | 1.80 | 2.10 |
| Insertion Depth | 3.0" | 3.0" | 3.0" | 3.0" | 3.0" | 3.0" | 3.0" |
| Nozzle | 0.50 X 80 | 0.65 X 80 | 0.85 X 60 | 1.00 X 60 | 1.25 X 60 | 1.50 X 60 | 1.75 X 60 |
| Spray Pattern | W | W | W | W | W | B | B |
| Pump Pressure | 145 PSI | 145 PSI | 145 PSI | 145 PSI | 145 PSI | 145 PSI | 145 PSI |
| Turbulator | 1 | 2 | 2 | 3 | 4 | 2 | 3 |
| Air Gate | 2-2.7 | 3.5-4.5 | 2.8-.3.4 | 3-5 | 4.5-6 | 2.8-3.4 | 3-4.1 |

8.2 Gas Burner Setup

This page is only for boilers using a gas burner. If an oil burner is being used, please refer to page 18 for the proper setup of the burner.

| Riello | | | Natural Gas | | | Propane | | |
|--------------|--------------|-------------|-------------------|--------------|----------|-------------------|--------------|----------|
| Boiler Model | Burner Model | Input (MBH) | Man. Pres. (W.C.) | Head Setting | Air Gate | Man. Pres. (W.C.) | Head Setting | Air Gate |
| B-4 | R200 | 110 | 1.06" | 2.2 | 1 | 1.32" | 2 | 1 |
| B-5 | R200 | 140 | 1.20" | 2.8 | 2 | 1.76" | 2.7 | 2 |
| B-6 | R200 | 175 | 1.46" | 2.8 | 3 | 2.34" | 2.9 | 3 |
| B-8 | R400 | 248 | 1.26" | 2.3 | 1 | 1.64" | 2.3 | 1 |

| Heat Wise | | | Natural Gas | | | | Propane | | | |
|--------------|--------------|-------------|-------------------|--------------|----------|------------|-------------------|--------------|----------|------------|
| Boiler Model | Burner Model | Input (MBH) | Man. Pres. (W.C.) | Head Setting | Air Gate | Orifice | Man. Pres. (W.C.) | Head Setting | Air Gate | Orifice |
| B-3 | SU-2A | 80 | 3.5" | 18 | closed | 3/16 | 2.0" | 22 | closed | 3/16 |
| B-4 | SU-2A | 115 | 3.5" | 12 | 3 | 7/32 | 2.3" | 12 | 3 | 7/32 |
| B-5 | SU-2A | 140 | 3.2" | 15 | 8.3 | 9/32 | 1.8" | 15 | 7.75 | 9/32 |
| B-6 | SU-2A | 175 | 3.5" | 10 | 13.5 | 21/64 | 2.3" | 10 | 13.5 | 21/64 |
| B-7 | SU-2A | 215 | 3.3" | 3 | 15 | 27/64 | 2.0" | 3 | 15 | 27/64 |
| B-8 | SU-3 | 272 | 1.7" | 1 | 3.25 | No orifice | 1.3" | 1 | 3.25 | No orifice |
| B-9 | SU-3 | 308 | 2.3" | 1 | 6.75 | No orifice | 1.7" | 2 | 6.5 | No orifice |

***Note: These burners may not be used on Biasi equipment in Canada**

Note: Consult burner manufacturers literature for gas manifold diagram and controls.

To determine how much gas is coming into the burner, or to set the gas meter correctly, the following formula can be used.

$$Ft^3/hr = [3600/(sec. Per rev.)]*(Size of gas meter)$$

The chart to the right can be used to determine the flow rate depending upon the time per revolution and the size of the gas meter dial.

| Seconds per Revolution | Size of Gas Meter Dial (Cubic Foot) | | |
|------------------------|-------------------------------------|-----|-----|
| | 0.5 | 1 | 2 |
| 20 | 90 | 180 | 360 |
| 25 | 72 | 144 | 288 |
| 30 | 60 | 120 | 240 |
| 35 | 51 | 103 | 206 |
| 40 | 45 | 90 | 180 |
| 45 | 40 | 80 | 160 |
| 50 | 36 | 72 | 144 |
| 55 | 33 | 65 | 131 |
| 60 | 30 | 60 | 120 |

9. Gas Line Piping

Gas supply piping is to be sized and installed properly in order to provide a supply of gas sufficient to meet the maximum demand without undue loss of pressure between the meter and the boiler. Consult with the **National Fuel Gas Code ANSI Z223.1** for proper sizing of gas piping for various lengths and diameters.

Locate a drop pipe adjacent to, but not in front of the boiler. Locate a tee in the drop pipe at the same elevation as the gas inlet connection to the boiler. Extend the drop line with a nipple towards the floor and cap to form a sediment trap. Install a shut off valve before the tee with sediment trap and a union after the tee before the combination gas valve.

When installing the boiler, make sure a pipe compound resistant to the action of liquefied petroleum is used. Check piping for leaks. Always check leaks with a water and soap solution. **DO NOT USE A FLAME FOR CHECKING GAS LEAKS**

The boiler and its individual shut-off valve must be disconnected from the gas supply piping during any pressure testing of that piping at test pressures in excess of 1/2 psi.

INSTALLATION OF SEDIMENT TRAP AND BURNER SUPPLY

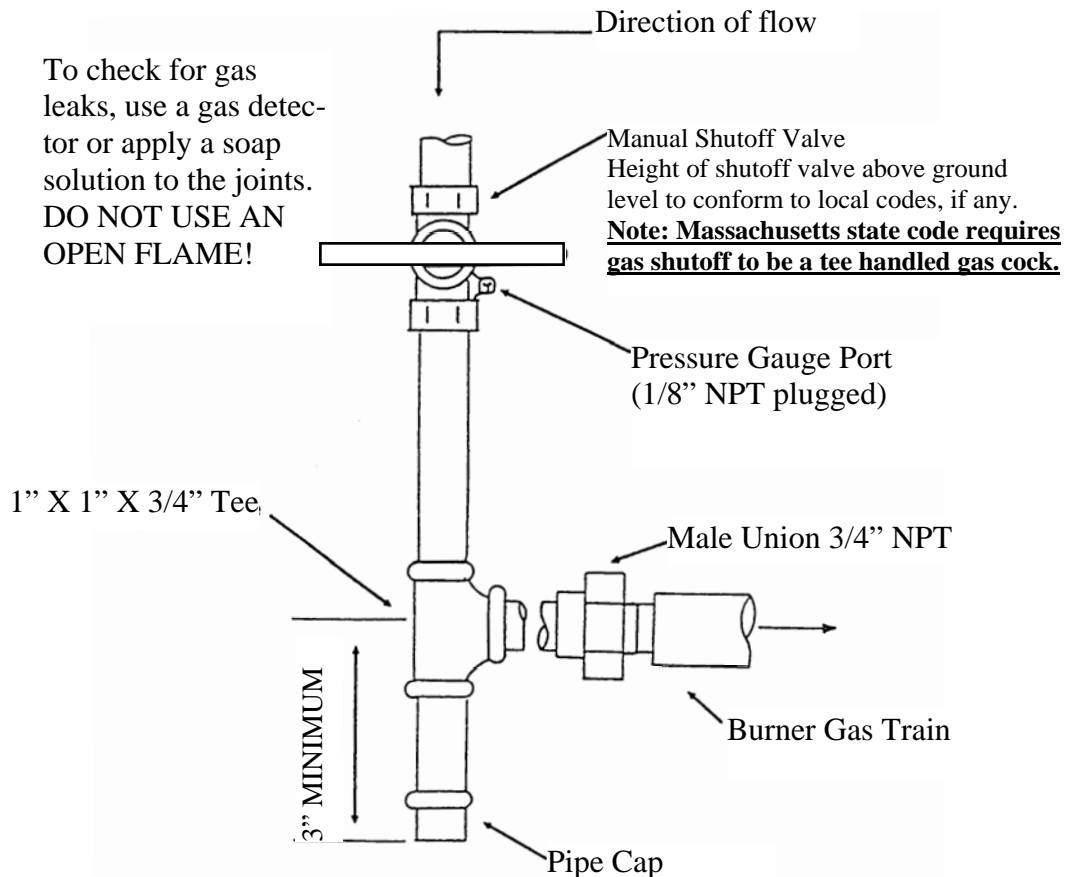

10. Boiler Jacket Assembly

NOTE: All piping, boiler controls, gauges and valves should be installed **before** the jacket is assembled on the boiler. Below is an explosion view of the boiler and jacket assembly to clarify these boiler jacket assembly instructions. Insert the separate (loose) piece of insulation on top of boiler with the foil side facing in so the entire top, bottom and sides of boiler are covered. Place tubular jacket spacers (#35 & #36 on exploded view of boiler) on the upper and lower draw rod extensions at the front(long spacers) and rear(short spacers) of the boiler. Place the rear insulated jacket panel (#26) at the back of the boiler, also by slipping over the slotted cut-outs. Position side jacket panels (#38 & #25) by slipping the slotted cut-outs over the boiler draw rods. Place the lower front jacket panel (#28) in place and secure with self-tapping screws provided. Fasten the washers and hex nuts to the ends of the tie-rods to hold the jacket in place. Set the top panel (#27) in place and secure with two screws in the back of the panel. With the jacket firmly secured, place front panel (#37) in position on the tabs on the side panels and press firmly to snap spring connectors in place.

NOTE: Do not attach any electrical wiring or electrical conduit or boiler piping to the top panel (#27).

Note: For replacement parts, contact your local Biasi Wholesaler.

Boiler Jacket Assembly:

- 25 RH Side Jacket Panel
- 26 Rear Jacket Panel *
- 27 Top Jacket Panel
- 28 Lower Front Jacket Panel
- 29 Top & Side Insulation
- 30 Front Panel Pin Clips
- 31 Self Tapping Screws (Qty 2)
- 32 Jacket Mounting Nut (Qty 8)
- 33 Jacket Mounting Washer (Qty8)
- 34 Front Panel Mounting Pins
- 35 Long Jacket Spacer (Qty 4)
- 36 Short Jacket Spacer (Qty 4)
- 37 Front Jacket Panel *
- 38 LH Side Jacket Panel

* Supplied with attached insulation

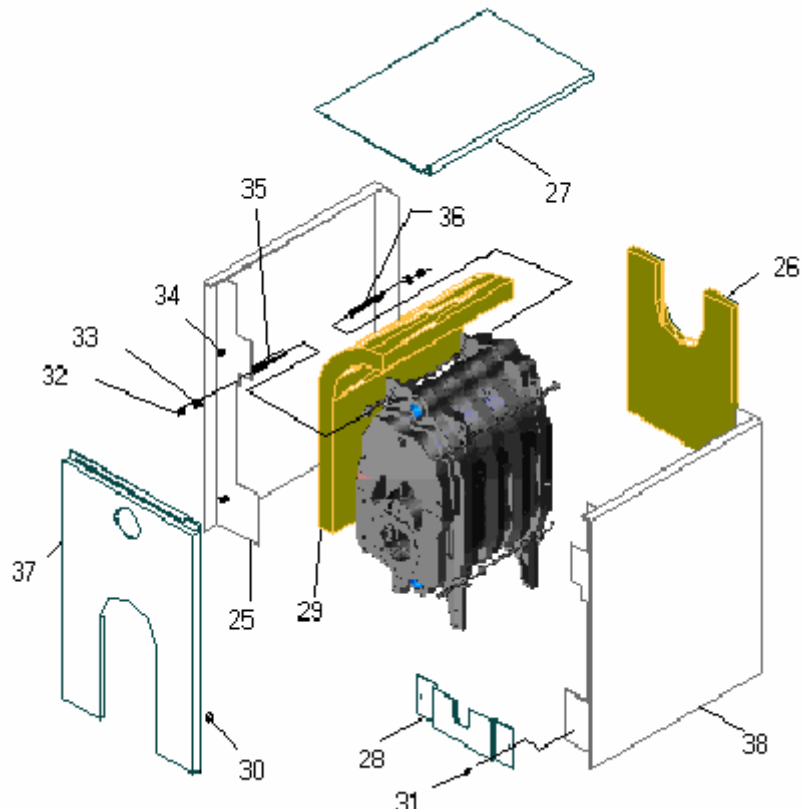

11. Wiring

The electricity to the boiler shall come from a dedicated breaker in the electric service box. A service switch should be mounted on the side of the boiler so the burner technician can service the burner and controls. The electrical wiring should be routed so as not to interfere with normal servicing of the boiler. Wiring done in the field between devices not attached to boiler shall conform with the temperature limitations for type T wire (63F/35C) or other specified wire as applicable when installed in accordance to manufacturer's instructions and wiring diagrams.

If an external electrical source is utilized, the boiler, when installed, must be electrically bonded to ground in accordance with the requirements of the authority having jurisdiction or, in the absence of such requirements, with the National Electrical Code, ANSI/NFPA 70 and/or the Canadian Electrical Code Part 1, CSA C22.1, Electrical Code.

Since the boiler is equipped with a swinging burner door, the supplied 48" long burner wiring harness with 4-prong quick disconnect plug needs to be used. The short end of the wiring harness needs to be wired to the burner following the respective burner wiring diagram in the subsequent pages of this manual. The long end of the wiring harness needs to be wired into the burner service switch located at the installers discretion.

Refer to pages 19 to 23 for oil wiring diagrams and pages 24 to 25 for gas wiring diagrams.

11. Wiring

4006A WIRING

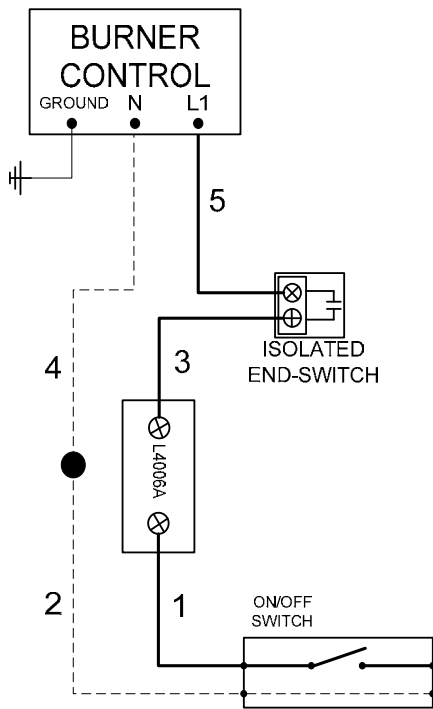

7248U WIRING

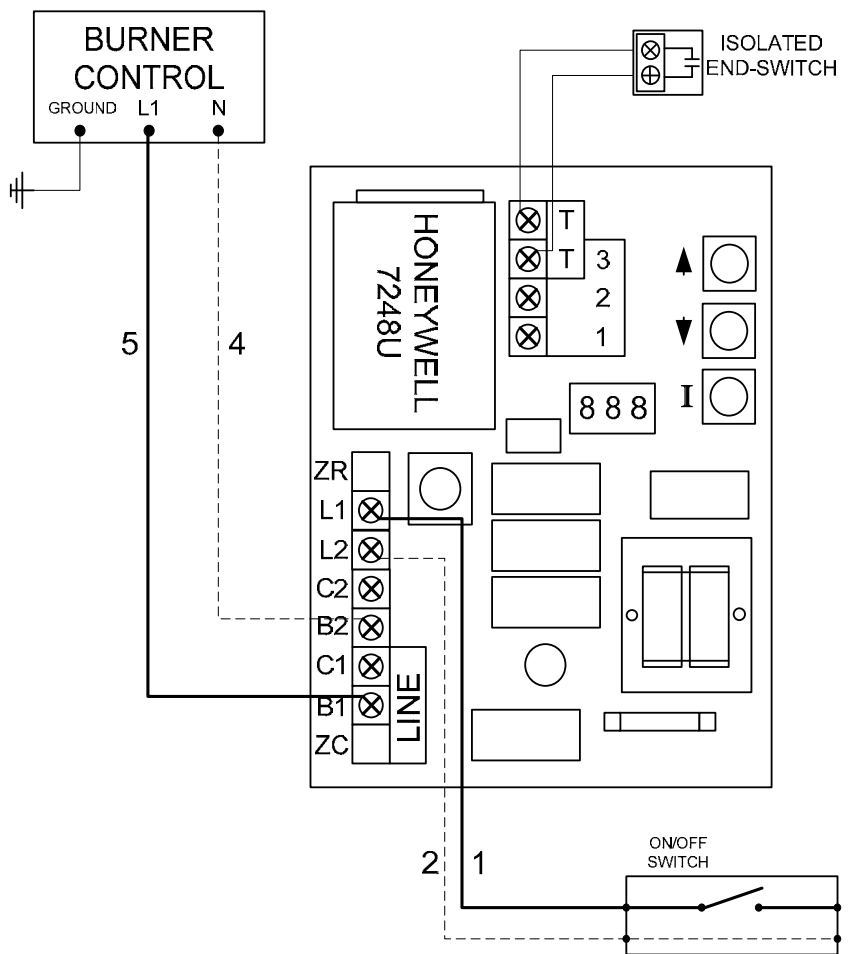

7248U WIRING PROCEDURE

If you received a Honeywell 7248U with your Biasi boiler, you will need to make the changes shown above, and described below to the wiring diagrams.

1. Run wire 1 to the L1 terminal on the 7248U instead of running wire 1 to the 4006A.
2. Run wire 2 to the L2 terminal on the 7248U instead of connecting to wire 4.
3. Run wire 4 to the B2 terminal on the 7248U instead of connecting to wire 2.
4. Run wire 5 to the B1 terminal on the 7248U instead of connecting to the isolated end switch.
5. Lastly, run low voltage wiring from the TT terminals on the 7248U to the isolated end switch.

11. Oil Burner Wiring

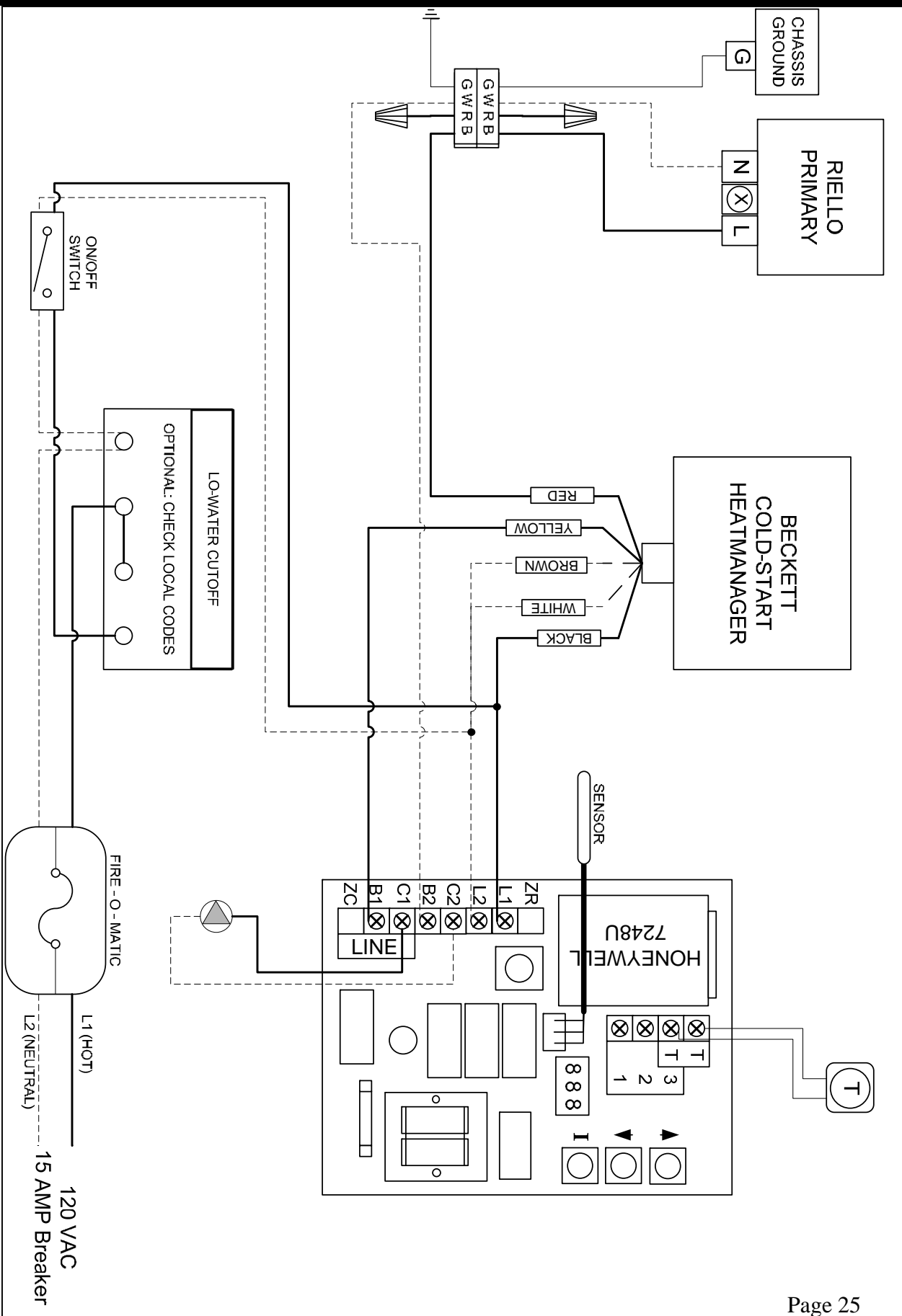

NOTE: All wiring must be done in accordance with applicable state, local and national codes. Use only copper conductors.

RIELLO OIL BURNER, SR504, CONTROL WIRING WITH DHW PRIORITY

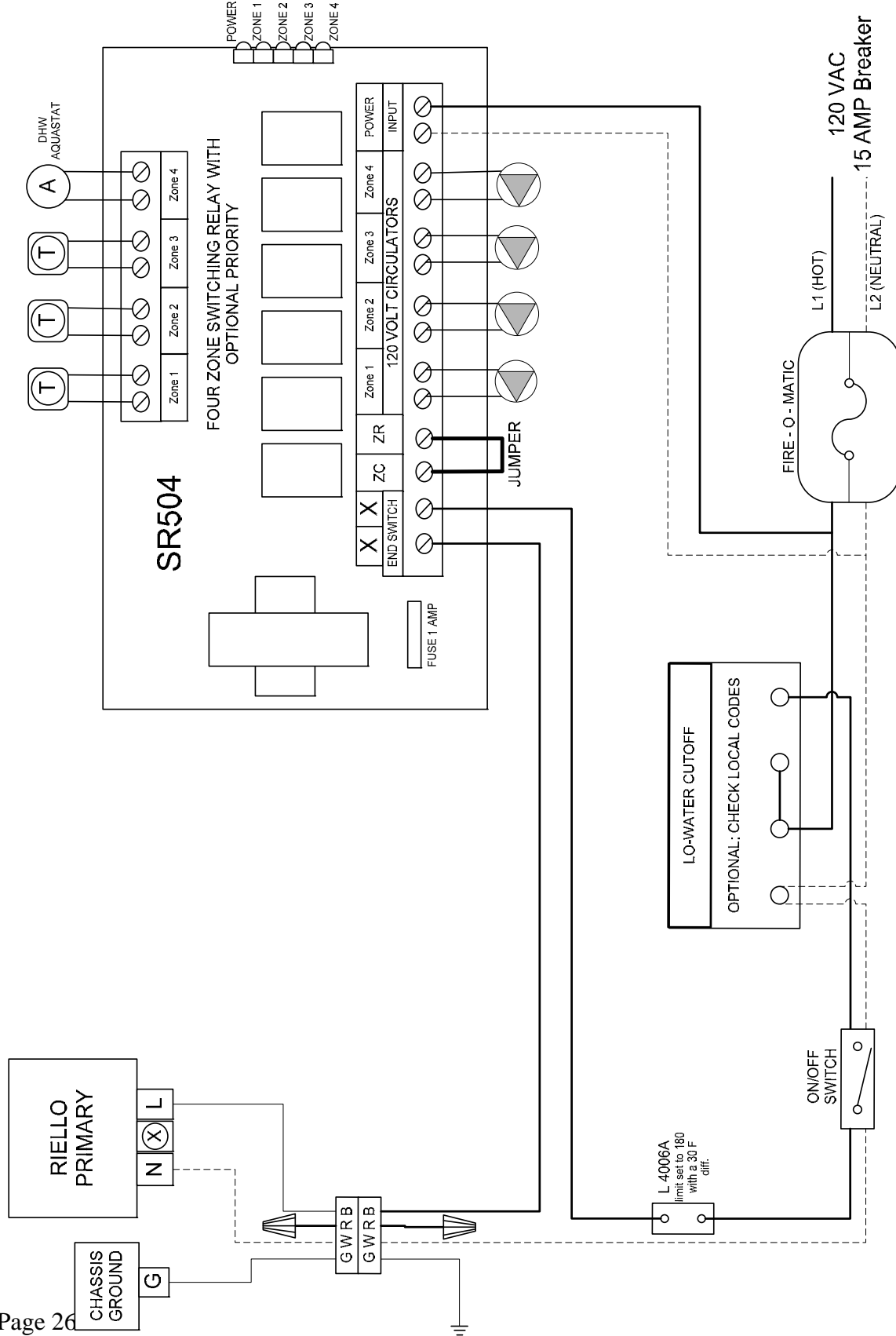

NOTE: All wiring must be done in accordance with applicable state, local and national codes. Use only copper conductors.

RIELLO OIL BURNER, AZ-4P, CONTROL WIRING WITH DHW PRIORITY

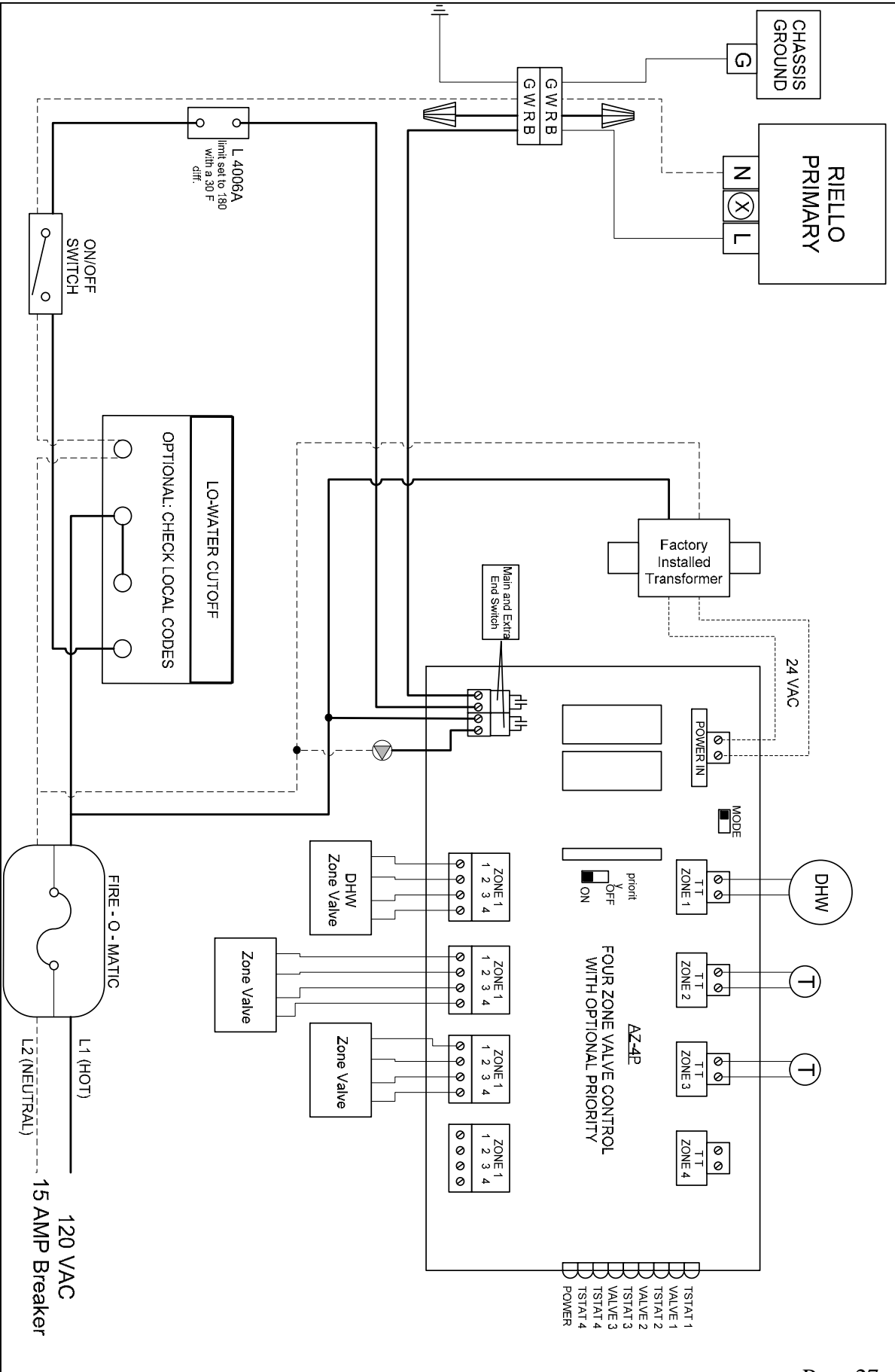

NOTE: All wiring must be done in accordance with applicable state, local and national codes. Use only copper conductors.

CARLIN OIL BURNER, SR501, CONTROL WIRING WITH DHW PRIORITY

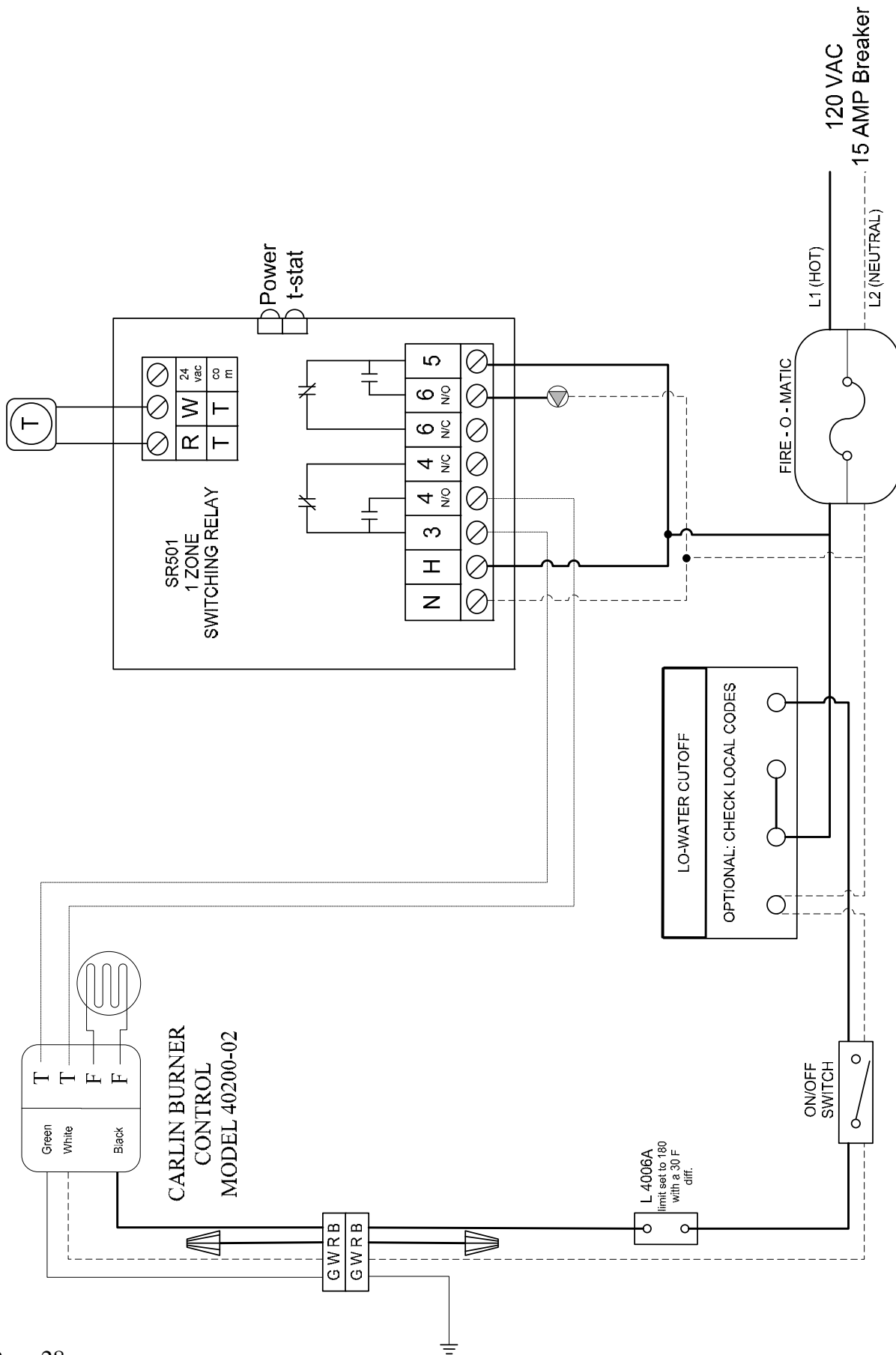

NOTE: All wiring must be done in accordance with applicable state, local and national codes.
Use only copper conductors.

BECKETT NO/AFI OIL BURNER, ARM-4P, CONTROL WIRING WITH DHW PRIORITY

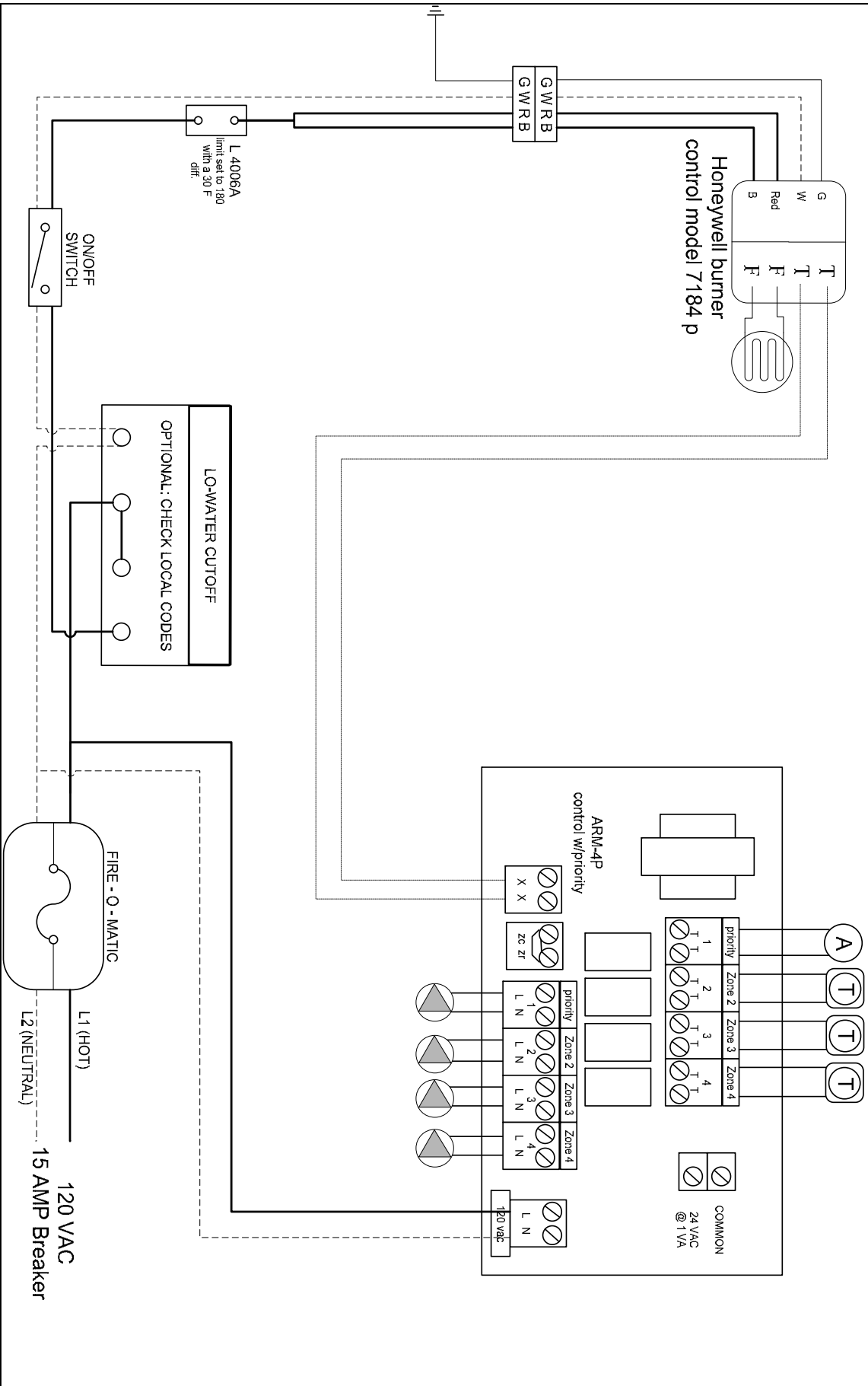

NOTE: All wiring must be done in accordance with applicable state, local and national codes.
Use only copper conductors.

RIELLO GAS BURNER, AR861-2II, CONTROL WIRING WITH DHW PRIORITY

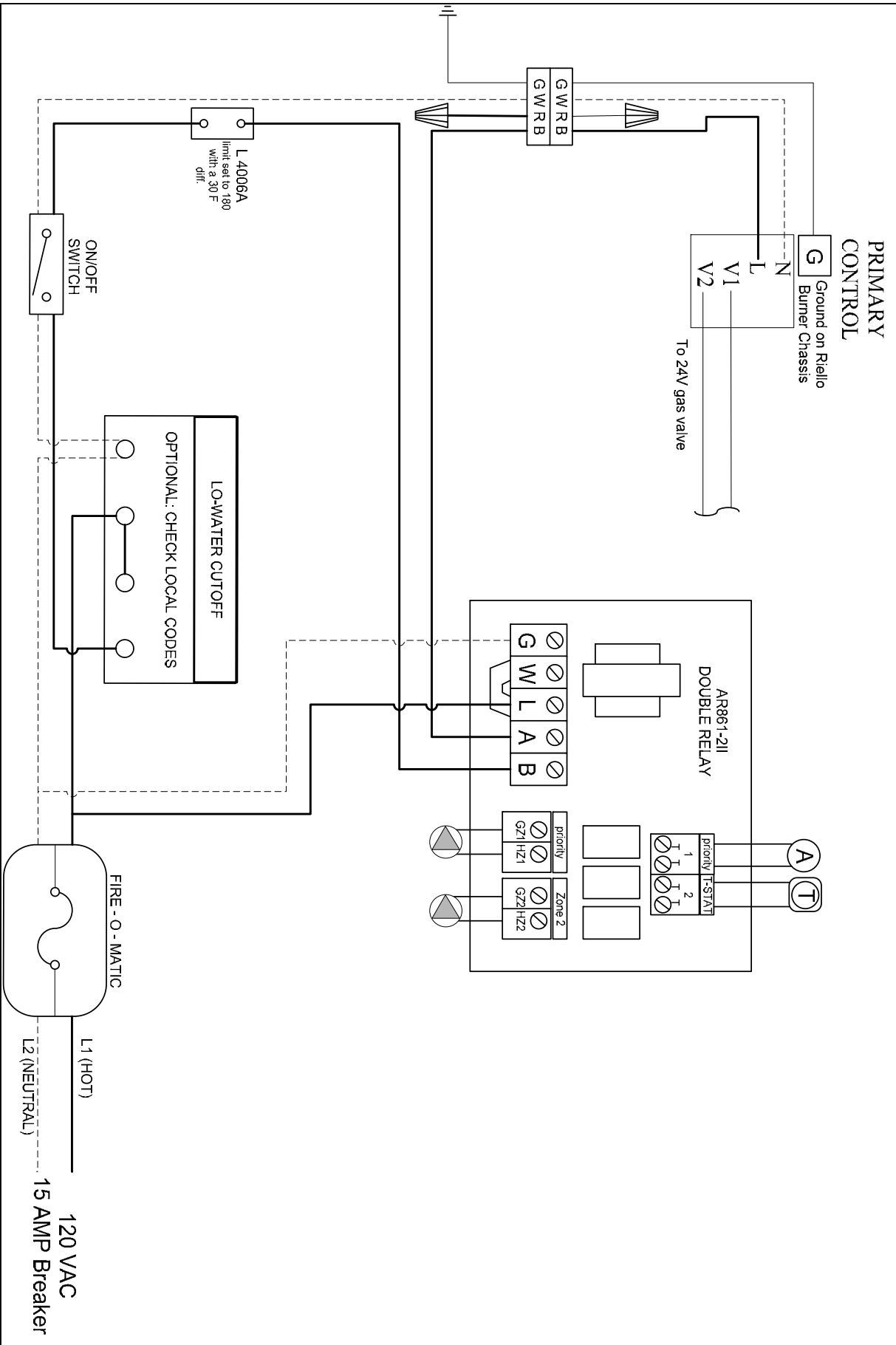

NOTE: All wiring must be done in accordance with applicable state, local and national codes.
Use only copper conductors.

12. Commissioning

Before a gas boiler may be put into operation and tested, it's gas connection must be leak tested. After installation of oil/gas-fired boiler, operation and performance tests shall be conducted to make certain that the burner is operating in an acceptable manner and that all safety controls and devices function properly. It is critical that the high limit, low water cutoff and burner "cad cell" relay be checked for normal operation before leaving the job.

CAUTION

Label all wires prior to disconnection when servicing controls. Wiring errors can cause improper and dangerous operation.

13. Maintenance

The Biasi boiler system should be serviced once a year.

1. Inspect the boiler and make sure it is operating normally, i.e. temperature and pressure.
2. Inspect the Pressure Relief Valve and manually set it off three times to ensure it is operating normally and not leaking.
3. If a Low Water Cut-Off is installed follow the manufactures suggested maintenance and test procedures.
4. Adjust room thermostat so there is a call for heat and test boiler high limit for proper operation.
5. Turn boiler safety switch off.
6. Open lower swing door and remove upper clean out plate.
7. Brush upper passages first and then clean combustion chamber of any debris with brush and vacuum.
8. Remove smoke pipe and clean out debris from cleaning or soot build up.
9. Inspect smoke pipe for any corrosion before reinstalling. Replace if necessary.
10. Consult the burner manufacturers manual for annual maintenance of the burner.
11. Remove all combustible materials from around boiler and ensure the area is free of debris so the burner has adequate intake air supply.

Notice

Verify proper operation after servicing.

14. Installer Notes

System Checkout:

Boiler Model No. _____ Serial No. _____

Original Purchaser:

Installer:

Burner Manufacturer-----

Type of Oil Burner-----

Burner Model No.-----

Burner Serial No.-----

Nozzle Manufacturer-----

Nozzle Spray Angle-----

G.P.H. -----

Type -----

Burner Performance Tests:

GROSS STACK TEMPERATURE -----

ROOM TEMPERATURE (AMBIENT) -----

NET STACK TEMPERATURE -----

CO₂ -----

O₂-----

SMOKE READING -----

COMBUSTION EFFICIENCY-----

COMMENTS _____

Warranty for BIASI - B10 Residential Cast-Iron Water Boilers

FIRST YEAR-WARRANTY FOR B10 SERIES RESIDENTIAL HOT WATER BOILERS: QHT warrants that its cast-iron boiler and casing are free from defects in material and workmanship for one year from the date of installation. If the boiler is found to be defective within this period, QHT will replace the boiler block or casing.

LIFETIME WARRANTY-WARRANTY FOR THE CAST IRON BOILER BLOCKS OF THE B10 SERIES RESIDENTIAL BOILERS: Biasi warrants that the cast-iron sections and nipples of the BIASI B10 boilers are free from defects in material and workmanship for the lifetime of the original single family home installation. If the B10 boiler block is then found to be defective, QHT and Biasi will replace the original cast iron boiler block.

These warranties are subject to the condition that a heating contractor whose principal occupation is the sale and installation of heating equipment must have installed the boiler. PARTS, WHICH ARE COVERED, consists of all materials supplied by Biasi, identified by QHT's part numbers in its literature. Other parts supplied in the casing, trim kit or in the burner pack carry their own warranty and each manufacturer has responsibility for its own products.

NOTE: ANY PART, WHICH IS REPLACED UNDER WARRANTY, CARRIES ONLY THE UNEXPIRED PORTION OF THE ORIGINAL WARRANTY.

OWNER RESPONSIBILITIES:

1. Provide for proper installation, which includes pressure relief and pressure reducing valves and high limit safety controls on closed systems.
2. Provide qualified periodic service to prolong proper operation and service.
3. Insure that boiler is installed with approved burner and that installation conforms to all codes and ordinances.
4. This warranty does not apply to boilers, which are subject to misuse, abuse, neglect, alteration, accident, excessive temperature, excessive pressure, or corrosive water or atmosphere.
5. Owner will be responsible for return of faulty components to

Portsmouth, NH, freight pre-paid.

QHT and Biasi will not be responsible for:

1. Components that are part of the heating system, but were not manufactured by Biasi or QHT as part of the boiler.
2. The workmanship of the installers of VEGA B-10 boilers. Furthermore, this warranty does not assume any liability for unsatisfactory performance caused by improper installation.
3. Any costs for labor to remove or replace the faulty component.
4. Improper burner application or adjustments, control settings, care or maintenance.
5. Any damage associated with corrosion or leakage due to the use of "non-barrier", plastic pipe in the heating system.

***THIS WARRANTY DOES NOT EXTEND TO ANYONE EXCEPT THE FIRST PURCHASER AT RETAIL AND ONLY WHEN THE BOILER IS IN THE ORIGINAL INSTALLATION SITE.**

***IMPLIED WARRANTIES OF FITNESS FOR A PARTICULAR PURPOSE AND MERCHANTABILITY SHALL BE LIMITED TO THE DURATION OF THE EXPRESSED WARRANTY. BIASI AND QHT EXPRESSLY DISCLAIM AND EXCLUDE ANY LIABILITY FOR CONSEQUENTIAL OR INCIDENTAL DAMAGES FOR BREACH OF ANY EXPRESSED OR IMPLIED WARRANTY.**

THIS WARRANTY GIVES YOU SPECIFIC LEGAL RIGHTS, AND YOU MAY HAVE OTHER RIGHTS THAT VARY FROM STATE TO STATE.

For prompt warranty service, notify the installer, who, in turn, will notify the distributor from whom he purchased the boiler. If this does not result in corrective action, contact Biasi through Quincy Hydronic Technologies (Address Below) with details in support of the warranty claim. All claims must be processed through proper trade channels. Contact with Biasi directly is not recommended for rapid claim settlement.

Quincy Hydronic Technologies,
80 Rochester Ave. Suite #12
Portsmouth, NH, 03801
Tel. (603) 334-6400

TEAR ON THIS LINE

BIASI BOILER WARRANTY REGISTRATION

IMPORTANT., Registration required. To gain complete warranty protection, fill in and mail this card immediately.

NAME _____
 STREET _____
 CITY _____ STATE _____ ZIP _____
 BOILER SERIAL NO. _____ DATE OF INSTALL _____
 NAME OF INSTALL CO. _____
 STREET _____
 CITY _____ STATE _____ ZIP _____
 B10 BOILER SIZE (EX. 4 SECTION) _____
 SILVER RATINGS LABEL SERIAL # _____
 HOW DID YOU HEAR ABOUT BIASI?
 DEALER/INSTALLER WEBSITE FRIEND/NEIGHBOR
 OTHER

**PLACE
STAMP
HERE**

QHT Inc.
80 Rochester Ave.
Suite #12
Portsmouth, NH 03801