

3 Wood Cast Iron Boiler

QHT BIASI

The New Style of Warmth

SAVE THESE INSTRUCTIONS



For wood and soft coal only.

Must be installed by a qualified licensed Heating Contractor.

IMPORTANT:

PLEASE READ THESE INSTRUCTIONS CAREFULLY BEFORE PROCEEDING WITH THE INSTALLATION OF THE BOILER. THESE INSTRUCTIONS MUST BE POSTED NEAR THE BOILER AND MAINTAINED IN LEGIBLE CONDITION FOR REFERENCE BY THE OWNER OR SERVICE PERSON.

OWNER:

For service and repairs to the heating system, please contact your Heating Contractor. The following information should be filled in by your Heating Contractor, and used by you when seeking information concerning the boiler.

Boiler Serial No. _____

Address: _____

Model No. _____

Telephone Number: _____

Heating Contractor: _____



Dear Customer,

Thank you for buying a BIASI 3Wood Boiler.

The 3Wood Boiler system is a cast iron, solid fuel, hot water boiler, using the famous Biasi (3-pass) design. This Boiler is rugged and engineered for maximum heating efficiency.

We realize that it is not possible to answer all the questions about the 3Wood Boiler System in this manual. Reading this installation Manual does not make the reader an expert in all aspects of installation and operation, and does not replace the need for a qualified, licensed heating contractor. We urge you to contact your installing contractor or distributor if you are in question about any aspect of your boilers performance. Our main concern is that you are satisfied with your boiler and its performance.

All BIASI boiler blocks are built in accordance with ASME boiler pressure vessel code, and bear the “H” stamp. The entire range of 3Wood Boilers have been tested to ETL standards.

The BIASI 3Wood boiler block has a limited lifetime warranty (refer to back of manual).

Thank you for purchasing our 3Wood series boiler. If you have any questions or comments call please don't hesitate to contact us immediately . Our goal is 100% customer satisfaction.

Sincerely,
QHT Inc.

Table of Contents

Important Information	4
Warnings and safety rules, Identification	5-6
Procedure in event of power failure	7
Refueling the Boiler	8
Wood Burning	9
Heat value of wood, Wood Storage, Ash Removal	10
Creosote, Runaway Fire	11
Chimneys	12
Coal Firing	13
3Wood Design	14
Installation Considerations	15
Layout of Main Components	16
Transporting and Minimum Clearances	17
Flue Gas Outlet and Combustion Air	18
Assembling the Casing	19
Installation of Controls	20
Installations of Flue Gas Partition and Draft Regulator	21,22
Commissioning the Boiler	23
3WOOD as only boiler piping and wiring	24,25
4 Way Mixing Valve Piping and Wiring	26,27,28
Parallel Piping and Wiring	29,30,31
Boiler and Casing Parts	32,33,34
Useful References	35
Shutdown	36
Troubleshooting	37
System Checkout	38
Warranty	39

Please read this page carefully.

ALL BOILERS MUST BE INSTALLED IN ACCORDANCE WITH NATIONAL, STATE AND LOCAL PLUMBING, HEATING AND ELECTRICAL CODES AND ORDINANCES, AS WELL AS THE REGULATIONS OF THE SERVING ELECTRICAL, WATER AND GAS UTILITIES.

All systems should be designed and installed by licensed heating contractors who are knowledgeable in the layout and installation of multi-fuel heating systems.

WARNING

- The 3WOOD Boiler must be positioned to provide at least 36" of clearance between any combustible material and the sides, rear, and top of the boiler. At least 60" must be provided between the front of the boiler and any combustible material. Boiler must be set on a non-combustible floor.
- Do not burn volatile garbage, gasoline, naphtha, propane, engine oil, or other flammable liquids. All flammable liquids (especially gasoline), debris, rags, paper, wood scraps, etc., should be kept clear of the boiler at all times. Keep the boiler area clean and free of fire hazards.
- All 3WOOD Boilers must be connected to a tile-lined flue with a minimum size of 8"x 8" or to an insulated metal chimney with a minimum size of 6". NO OTHER APPLIANCE SHOULD BE VENTED THROUGH THIS FLUE! Your chimney flue should be inspected regularly (BI-Monthly) for any build up of fly ash or creosote.
- It is the responsibility of the installing contractor to see that all controls are correctly installed and are operating properly when the installation is completed.
- Please read the literature and warranty supplied by the manufacturer of the various accessory devices.
- These devices are warranted by the manufacturer, not by QHT, Inc. or BIASI. These accessory devices must be installed and used according to the recommendations of the manufacturer.
- Do not use self contained, non-electrical zone valves in the zone controlled by the overheat control.
- When references are made to tapping numbers, please refer to the specifications sections.
- All firewood used in this boiler must be dried to moisture content of 20% or less. (see pg.11)
- Homeowners should read and familiarize themselves with "Procedure In Event Of Power Failure". (see pg.9)
- Anyone who is going to operate this boiler MUST read and familiarize himself or herself with "Starting And Maintaining A Fire". (see pg.23)

DANGER

COAL FIRES CAN PRODUCE POISONOUS GASES!

All coal fires produce large quantities of carbon monoxide (CO), a highly poisonous gas. Exposure to this gas produces drowsiness, sleep and, in some cases, brain damage or even death. Since carbon monoxide is odorless and colorless, the victim is rarely aware that he or she is being overcome until it is too late.

Normally, carbon monoxide burns as a blue flame over the coal bed, but under and of the following conditions, unburnt carbon monoxide gas could escape from the combustion chamber, stove pipe, flue or chimney and enter the house:

- A blocked chimney
- An internal blockage in the heating appliance that can be caused by a build up of ashes, poor positioning of the coal, or firing with too much fuel.
- A closed smoke pipe damper
- A poor chimney draft

If you are burning coal or plan to burn coal, make certain that none of the conditions listed above exist. If you have any questions about coal burning, please consult with your contractor or the BIASI Distributor.

Codes and Regulations

Installation of the boiler, and related equipment must conform to national, state and local regulations codes applicable to the installation of the equipment. In the absence of local requirements, the following codes apply:

National Fire Protection Association (NFPA)

Battery March Park
Quincy, MA 02269
<http://www.nfpa.org>

CSA International

8501 East Pleasant Valley Road
Cleveland, OH 44134
www.csa-international.org

WARNING SAFETY RULES

- After removing the packaging, check that the material supplied is intact and complete; if this is not the case, contact the heating contractor that sold the 3WOOD Boiler.
- The 3WOOD Boiler must be installed by a licensed heating contractor in compliance with the National, State and Local codes in force and the instructions provided in the manual supplied with the 3WOOD.
- The 3WOOD Boiler must be used for the intended purpose. QHT BIASI is not liable for any injury or damages caused to people, animals or things due to errors in installation, operation, maintenance and improper use of the boiler.
- In the event of water leaks, close the water supply and call your Heating Contractor.
- The manual is an integral part of the 3WOOD and consequently must ALWAYS be kept with the 3WOOD Boiler when transferred to another owner or user, or installed in another system. The manual must be kept carefully and if damaged or lost a replacement can be ordered by calling QHT Biasi.(1-800-501-7697)
- The 3WOOD Boiler is not to be used with an automatic stoker unless so certified.
- **The 3WOOD Boiler must be serviced at least once a year.**
- **Caution: Hot surfaces; keep children away. Do not touch during operation.**

WARNING – RISK OF FIRE.

- **DO NOT** allow the boiler to be controlled by children or incapable persons without supervision.
- **DO NOT** use chemicals or fluids to start the fire.
- **DO NOT** burn garbage, gasoline, naphtha, propane, engine oil, or other flammable materials.
- **DO NOT** fire the **3WOOD** during a power failure. Use a wood stove during a power failure not a wood boiler.
- **DO NOT** dispose of ashes in anything other than a steel container and do not store it in house.
- **DO NOT** let the chimney draft exceed .2 inches of water column
- **DO NOT** adjust or tamper with the chain which connects the Samson draft regulator to the air damper
- **DO NOT** perform any cleaning operations when the boiler is hot or when there are coals inside the boiler.
- **DO NOT** adjust the safety or control devices without consulting with the instructions of the manufacturer of the boiler.
- **DO NOT** plug or reduce the size of the ventilation openings in the room where the boiler is installed and on the boiler (if present). The ventilation openings are essential for correct combustion.
- **DO NOT** leave containers with flammable substances in the boiler room where the boiler is installed.
- **DO NOT** operate with fuel loading or ash doors open.
- **DO NOT** store fuel or other combustible materials within marked installation clearances.
- **DO NOT** overload the combustion chamber.

NOTE: Inspect and clean chimney flue regularly.

DANGER

DO NOT connect to any chimney or vent serving another appliance.

NOTE: For Canadian Installations, the boiler must be installed as per the following Requirements:

- **CAN/CSA-B365 Changes to the installation must comply with CAN/CGA-B149.1**
- **Can/CGA-B149.2 (for gas fired), C22.1 (for electric), CSA B139 (for oil fired)**

WARNING -Canadian

- Operate the (gas, Oil, Electric) boiler periodically to ensure that it will operate satisfactory when needed.
- DO NOT relocate or by-pass any of the safety controls in the original boiler installation.
- The operation of the gas boiler must be verified for acceptance operation before and after installation of the add-on boiler by a gas fitter who is recognized by a regulatory body.

Note: Only wood and bituminous coal can be burned in this boiler.

IDENTIFICATION

The 3WOOD Boiler is identified by:

- The **ASME Name Plate** that MUST be applied by the heating contractor, after assembling the casing, so that it is legible when the 3WOOD is installed (for example, on one of the side panels as shown on page 20).
- The ETL Plate is fastened to the boiler casing.

Before Installing

WHEN SERVICING BOILER

- To avoid electric shock, disconnect electrical supply before performing maintenance.
- To avoid severe burns, allow boiler to cool before performing maintenance.

BOILER OPERATION

- Do not block flow of combustion or ventilation air to boiler.
- Should overheating occur do not disconnect electrical supply to circulator. Instead, open all the flow checks external to the Boilers.
- Do not use this boiler if any part has been under water. Immediately call a qualified service technician to inspect the boiler and to replace any part of the control system.
- Do not overload the boiler.

BOILER WATER

- If you have an old system with cast iron radiators, thoroughly flush the system (without boiler connected) to remove sediment.
- Do not use petroleum-based cleaning or sealing compounds in boiler system.
- Use only inhibitors propylene glycol which are specifically formulated for hydronic systems.
- Continual fresh make-up water will reduce boiler life. Mineral buildup in heat exchanger reduces heat transfer, overheats the stainless steel heat exchanger, and causes failure. Addition of oxygen carried in by make-up water can cause internal corrosion in system components. Leaks in boiler or piping must be repaired at once to prevent make-up water.

Should your electricity go off during the heating season, there are several procedures that should be followed in order that you may continue to safely operate your heating system. These procedures apply to the solid-fuel boiler, as the gas or oil-fired boiler, if any, will be completely inoperative.

1. Locate any “flow-check” valves in the system (See Pg. 7), and completely unscrew the knob on the top of all these valves. (This will allow a certain amount of heated water to circulate by convection throughout the house, preventing the pipes from freezing and keeping the house partially heated).
 Note: This does not apply to gravity systems, as they have no flow-check valves, and will continue to operate normally without electricity.
2. The automatic draft regulator will continue to control the wood fire in the absence of electric power. It is important to remember that the heating system cannot dispose of a great deal of fuel without a circulator running.

Auxiliary “Dump Zone” Utilizing Natural Thermal Circulation During Power Failure

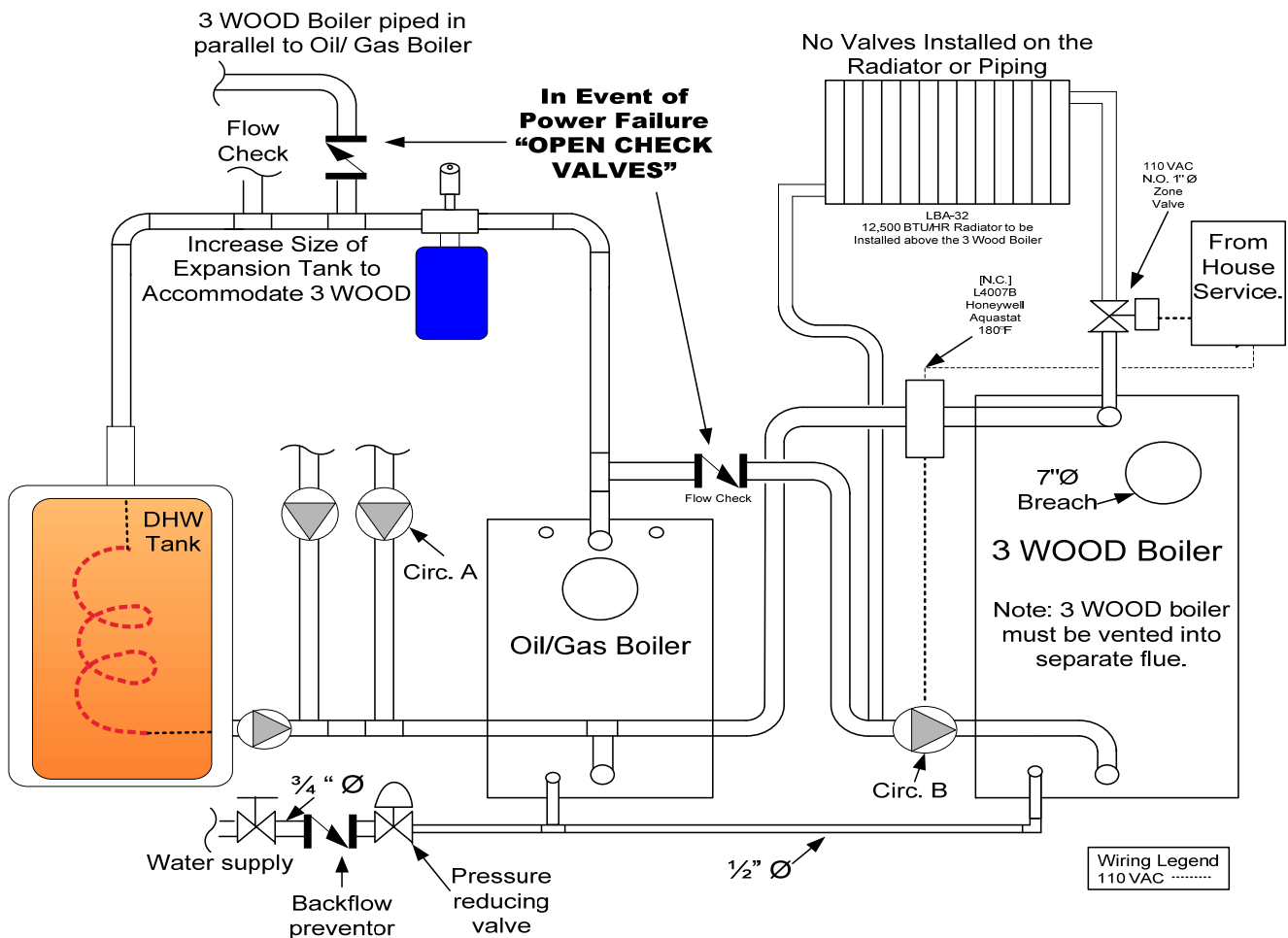

PIPING NOTES:

1. This drawing is meant to show system piping concept only. The installer is responsible for all equipment & detailing required by local codes.
2. Discharge of Pressure Relief Valve must be piped without valves to within 3" of the floor.
3. Where required, Low Water Cutoff must be installed in the Supply piping of the oil/gas boiler

REFUELING THE BOILER

CAUTION

- Use extreme caution when refueling the boiler. If the door is opened too quickly, the unburned hot gases may ignite and cause a back puff. This is especially true with very dry wood.
- DO NOT tamper with the chain on the draft regulator as it could cause the fire to burn out of control.
- Keep ash and fuel doors closed if not refueling boiler.
- DO NOT overload the boiler.

Adjusting the Flue Gas Damper

To Re-fire the boiler, open the flue gas damper to establish more draft through the combustion chamber. After refueling, when the fire is established, it probably will be necessary to close the flue gas damper to match the heating requirements and accommodate the chimney draft.

Reloading Wood

CAUTION

To reload wood in the firebox, Carefully open the top fire door an inch or so until you can see that the fire is burning well and the smoke is exhausting up into the heat exchanger above the firebox. While loading, the door can be left fully open and logs can be added by swinging the flue gas damper open. Logs should be 1” or 2” shorter than the firebox in the boiler and should be of such diameter as not to “bridge” or jam in the firebox. Logs of 2” to 4” in diameter should be used whenever possible. This will produce an even burning and efficient fire. Wood split to this size also dries much more quickly. The logs should be stacked and lined up horizontally so the burning wood can settle easily. Add the largest wood when the fire is burning well and some coals are forming. After you have filled the firebox to the desired level, close the loading door securely. Damage or injury will result if wood is not loaded carefully generally level with bottom of flue gas damper. If loaded in-correctly there is a risk of fire or injury.

In long- term maintenance of the boiler fire, frequent stoking with small amounts of wood is better than infrequent stoking with larger amounts. When you stoke the fire, pull some of the hot coals forward in the firebox where they can get sufficient air to burn thereby enabling them to set fire to the next load of wood.

Draft Regulator

The draft regulator should be adjusted as follows:

It may take several trials adjusting the Samson control setting to maintain the proper boiler temperature during wood firing of approximately 180-190°F. The final control setting may be a little more or a little less than the red 80°C on the dial. During normal operation, especially in the spring or fall, it is necessary to allow air to enter through the secondary air damper. This method reduces the possibility of creosote formation when the lower air flap is fully closed.

1. Turn the black knob counterclockwise to set the red number from 40°C to 80°C at the red line.
2. Allow the wood fire to slowly bring the boiler temperature up to about 180°F on the temperature gauge.
3. As this temperature is reached, the lower door air inlet flap will begin to close because the proper combustion of air has entered the firebox to maintain the selected boiler temperature.

DO NOT tamper with the chain on the draft regulator as it could cause the fire to burn out of control.

CAUTION

Empty the ashes before they touch the grates so they will not interfere with the airflow to the vertical flue passages

WOOD BURNING

Overview

Burn dry and well-seasoned hardwood with a moisture content of 20% or less. Wood must be seasoned at least six months; however, it is preferable to season it for a year to eighteen months. Seasoned wood will not only reduce creosote but will also produce more heat. Some seasoned hardwoods will yield 20-25% more heat. Wood-burners who ignore this advice are likely to have dirty chimneys and inadequate performance from their boilers.

Theoretically, there are about 8,600 BTU available as heat from each pound of wood. It takes about 1,000 BTU to evaporate each pound of moisture from a log. The wetter the wood, the more energy it takes to get the moisture out of the firewood resulting in less energy to heat your home. In addition, green wood usually burns at a low temperature, robbing you of even more heat in the form of unburned chemicals and gases that it sends up the chimney. **The moral is: do not burn green wood.**

Selecting Your Wood

If you buy green wood, season it before using. With some experience, you can spot green wood easily. It is heavier and it looks different. Seasoned wood will often show cracks radiating outward from the heartwood toward the bark, like wheel spokes. Green wood will not show this pattern of cracks.

You get roughly the same amount of heat from a pound of equivalently dry wood no matter what species of tree it comes from. But wood is not sold by the pound; it is sold by the cord i.e. by volume. Therefore, the dense heavy woods are the ones to buy, the ones that give you more pounds per cord. A cord of wood measures 4 feet x 4 feet x 8 feet. A cord of 4-foot logs thus stacked occupies 128 cubic feet and contains about 80 cubic feet of solid wood, with the rest being air space between the logs. If you buy a cord of wood, cut it to length and split it, you will find it does not occupy 128 cubic feet when stacked. You have not necessarily been cheated. A cord cut to length and split packs more tightly thereby occupying less space. Often the best time to buy wood is in late winter or early spring. Green wood can sometimes be purchased at low prices in spring or early summer.

Cutting and Drying Your Own Wood

A good time to cut your own wood is in the late winter or early spring, as soon as the woods are free of snow. Then hold the wood for use in 18 months. If you cut trees in the spring or summer, let them lie a while until the leaves wither. The leaves will draw moisture from the wood; drying it more quickly than if you limbed the tree immediately.

If you want your wood to dry as quickly as possible, cut it to length and split it. Stack it where the air can move through the pile and shelter it from the weather. A wood shed with air vents in the sidewalls, like a tobacco-drying barn, is effective.

The Heat Value of Wood

The following chart compiled by the United States Forest Products Laboratory indicates the amount of heat available per cord of wood from a few representative tree species. Other good to very good species would include apple, walnut, pecan, dogwood, cypress, sycamore and gum. The latter two are hard to split, as is elm.

Available Heat Per Cord			
In Millions of BTU/ HR			
Species	Green Wood	Air-Dry	Percent More Heat For Air-Dry Wood
Ash	16.5	20.0	21
Aspen (Popple, Poplar)	10.3	12.5	25
Beech, American	17.3	21.8	26
Birch, Yellow	17.3	21.3	23
Douglas Fir, Heartwood	13.0	18.0	38
Elm. American	14.3	17.2	20
Hickory, Shagbark	20.7	24.8	19
Maple, Red	15.0	18.8	24
Maple, Sugar	18.4	21.3	16
Oak, Red	17.9	21.3	19
Oak, White	19.2	22.7	18
Pine, Easter White	13.1	13.3	10
Pine, Southern yellow	14.2	20.5	44

WOOD STORAGE

Store your wood outside of the minimum clearances recommended on the drawings on page 19. Generally wood should be stored in the basement or barn, garage where insects wont bother the house. If fans are installed within fuel storage area, they should not create negative pressure in the room where the 3WOOD is located.



ASH REMOVAL

Before refueling the boiler, check the ash pan under grates and remove and dump ashes if full into a metal container. Replace the ash pan and close the ash door. After re-fueling, take the ash container and leave it outside the house.

CREOSOTE

Creosote condenses from the flue gases more quickly when the temperature in the chimney is low. The actual amount of creosote deposited is dependent on:

1. The amount of moisture in the flue gases.
2. The temperature of the stack,
3. The rate at which the wood is burned.
4. The amount of draft in the stack.
5. How completely the combustible elements in the flue gases have been burned in the combustion chamber. Most problems with creosote are due to insufficiently dry wood, poor chimney with low draft and cold walls, and/or a low rate of burning when little heat is required during the spring and fall months.

Moisture in the flue gases may be controlled by:

- Using properly seasoned firewood.
- Mixing small pieces (preferably slab wood) with every full load.
- Never use only large wood (usually less dry) during mild weather when combustion is relatively slow.

The temperature in the stack may be controlled by:

- Using as short a length of stovepipe with as few elbows as possible between the boiler and the chimney.

The amount of draft in the stack may be controlled by:

- Insuring adequate chimney height and preventing air leaks in places such as around the ash pit door.
- Eliminating external obstructions in the chimney outlet.
- Insulating chimney from heat loss.

CAUTION

Procedure in the event of a runaway fire or chimney fire

If the Boiler-Fire is out of control (or creosote in chimney has caught fire) Do the Following:

- Close flue gas damper
- Turn knob on draft regulator to 40°C
- Turn-up thermostats in house
- **DO NOT** dose the fire with water as injury from steam could occur

WARNING

Do NOT connect this unit to a chimney flue serving another appliance.

Downdrafts

Downdrafts can result from improper chimney height, nearby buildings, tree that are taller than the chimney, and too large of a flue. To help minimize this problem, the top of the chimney must be at least three feet above the point at which it passes through the roof and two feet above the highest point of the roof. In addition, the chimney should be at least as high or higher than the tallest section of any adjacent roof.

WARNING

Chimney Construction

Fire insurance underwriters favor and sometimes require masonry construction for chimneys because tile-lined masonry chimneys are strong and not likely to crack from high temperatures.

Insulating your chimney flue liner will create a consistent natural draft by keeping the temperature of the flue gasses higher than the atmospheric temperature around the chimney. Insulation will also reduce creosote deposits by reducing the moisture condensation from the flue gases.

- 3WOOD must be connected to its own separate flue. It must NOT be installed in a flue which is connected to another appliance.
- The recommended low heat, tile lined, masonry chimney should have a minimum 8" x 8" flue and be at least 18 feet tall.
- A H.T. metal chimney is recommended and should have a stainless steel liner 7"ø.
- **The exhaust pipe should be minimum 24 gauge and 7"ø black or blued steel.** It is suggested to point the male end of the pipe downward to prevent leaking creosote.

Chimney Cleaning

Check your chimney and flue pipe at least twice during the heating season. check it more frequently if you are new to wood or believe that there is soot or creosote build up.

A small amount of smoke can infiltrate the room when you refuel the boiler.

However, if this happens increasingly you may have a chimney blockage. To find out the cause, look into the chimney from above or below. If neither option is convenient, then use a mirror and a flashlight to look up the flue utilizing the clean out door as an access point.

To clean your chimney, you can contact a professional chimney sweep or use several do-it-yourself cleaning methods. The most efficient device for scrubbing your chimney flue is a wire chimney brush that is designed for cleaning solid fuel flues. These brushes are available in standard sizes for both rectangular and round flues. Another option is to fill a burlap bag with straw or rolled up chicken wire, tie it to a rope and drop the rope down to a helper. You can then pull the bag up and down in the chimney to scrub away and buildup. Similar methods include using a bunch of tire chains tied to a rope or tying a burlap sack to the end of a long pole, provided your chimney is not too tall.

Chemical chimney cleaners such as "chimney sweep" are available. These products are added to the hot fire in order to break down the creosote. We do not know how their long term effects on a chimney or boiler, but we have been advised that any chemical salt added to the fire may cause corrosion in insulated metal chimneys, boilers, and stovepipes. In addition, these products can be harmful to your health.

DANGER

COAL FIRES CAN PRODUCE POISONOUS GASES!

All coal fires produce large quantities of carbon monoxide (CO) a highly poisonous gas. Exposure to this gas produces drowsiness, sleep, and in some cases, brain damage or even death. Since carbon monoxide is odorless and colorless, the victim is rarely aware that he or she is being overcome until it is too late.

Normally, carbon monoxide burns as a blue flame over the coal bed, but under any of the following conditions, unburnt carbon monoxide gas could escape from the combustion chamber, stove pipe, flue or chimney and enter the house:

- A blocked chimney
- An internal blockage in the heating appliance that can be caused by a building up of ashes, poor positioning of the fuel, or firing with too much fuel.
- A closed smoke pipe damper
- A poor chimney draft.

If you are burning coal or plan to burn coal, make certain that none of the conditions listed above exist. If you have any questions about coal burning, starting or maintaining a coal fire please consult with your contractor.

CAUTION

BURN BITUMINOUS (SOFT) COAL ONLY

Your success with coal burning will improve with experience, as it takes time to familiarize yourself with your new boiler and various fuels. Getting the maximum heat out of your coal generally depends on these factors:

- Proper firing technique with adequate draft.
- Clean heat exchanger surfaces in you boilers.
- Quality Bituminous (soft) coal of the proper size. (1-1/2" -2-1/2" diameter coal).

It is best to build a coal fire by gradually adding coal over a well established bed of wood coals. Before adding fuel, check to see that the ashes are removed from the lower door and that there is clear draft up through the grate area.

The type, quality and size of the coal you are using will affect the kindling rate and time required to establish a good, deep coal bed.

There are no set rules, but the following suggestions may help:

1. Don't run too low a fire. Once you have a good hot coal bed, keep the firebox full to the level of the fire door. Bank the coal bed sloping down to the sides and the front below the bottom of loading door. A good deep fire is more economical than a low, thin one. **DO NOT** overload the combustion chamber.
2. Be sure to leave a "hot spot" (an area of exposed, glowing coals) to ignite the gases released from the fresh coal.
3. Be sure to clean out ashes from below grates before adding fuel. Be sure to remove and store ashes only in a metal container, preferably with a cover like a trash can, some people even sift ashes to remove large unburned chunks of coal to be reburned. Glowing embers in a bed of ashes can remain hot for many days– so be very careful of how you dispose of ash from both wood and coal fires!
4. Don't allow coal dust and soot to accumulate on the inside surfaces of your boiler. Coal dust has an even higher insulating value than creosote, so it is a good habit to brush away any accumulation daily. Be careful to check the cleanout in the rear smoke hood at least once a week.
5. Don't disturb the fire once you have a good coal bed.
6. If you have trouble starting or maintaining a fire, you may want to mix fuels. Generally, softer coals kindle and burn better in smaller fireboxes and start up better. Coal over wood coals and gradually establish a good coal fire with bituminous "chestnut", "stove", or "egg" coal. You can also freely mix various wood types. A good way to clean any creosote buildup from a regular wood fire is to occasionally burn 100-200 pounds of coal.)

SPECIAL PRECAUTIONS MUST BE TAKEN WHEN BURNING COAL TO AVOID DANGER DUE TO CARBON MONOXIDE GAS POISONING.

The 3WOOD Design

The **3WOOD** Boilers are hot water generators that operate by combustion of hard wood or soft coal. They feature a high quality and extremely thick ASME class 20 cast-iron body, protected by high-density insulation that limits heat loss.

The large heat exchange surface and the fins in the flue gas path ensure exceptional resistance to corrosion and very high efficiency that remains constant over time (self-cleaning effect).

The combustion chamber and the upper door for loading the wood are sufficiently large to maximize the burn time and limit the number of times the door needs to be opened for refueling.

The front air grille for secondary air in the upper door and the flue gas damper are easily adjusted for tending the fire.

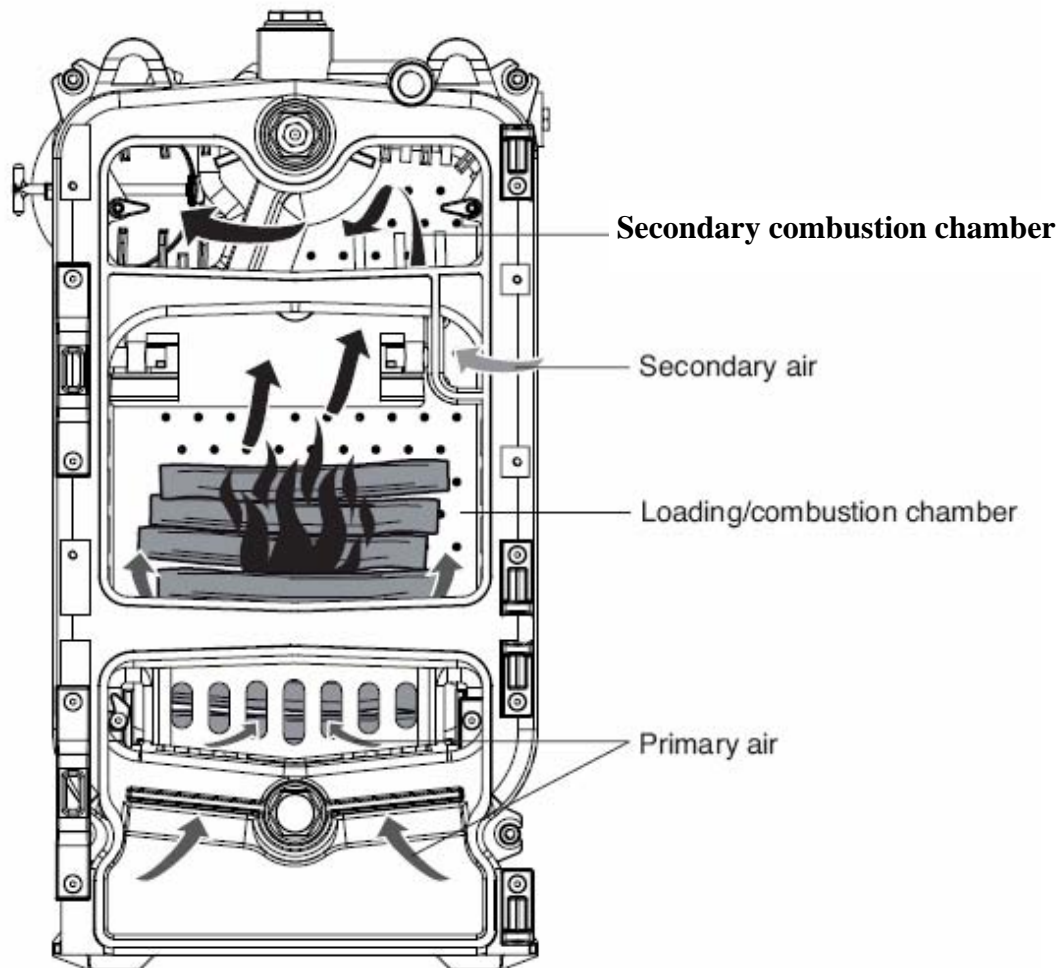

Technology with 3 Pass:

1st Pass

The combustion chamber gasses are carried by a special passage in the rear element. In the same area, very hot secondary air is combined with combustion gases which enhance their oxidation.

2nd Pass

The gases from the rear element are reburned in the secondary combustion chamber,

3rd Pass

The third Pass consists of a wide-finned, self-cleaning zone which directs the smoke towards the flue attachment with adjustment shutter and door cleaning.

When the 3WOOD is installed, check that The flue, if reused:

- Supplies the negative pressure required for the new boiler (see the table of technical specifications on page 10);
- is suitable for the temperature of the products of combustion, and has been calculated and constructed according to the required standards; recommended by NFPA
- is as straight as possible, airtight, insulated and is not blocked or choked;
- is fitted with a cleanout door
- The heating system should be flushed, cleaned of any slime and deposits, vented and tested for water tightness.
- The heating system should be equipped with a new expansion tank of sufficient size to handle the volume of both boilers.
- The 3WOOD Boiler should be equipped with its own make-up water.

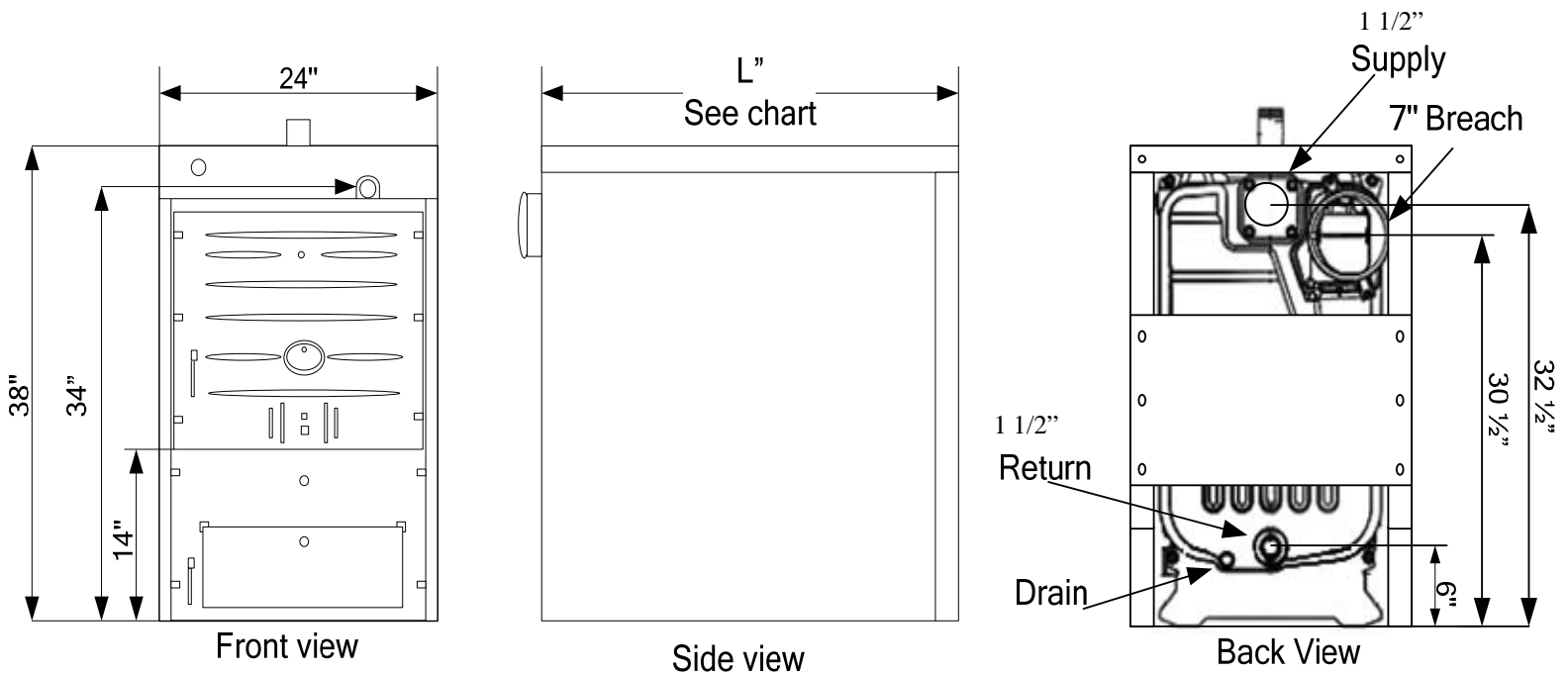

Model #	Min. Output (BTU/HR)	FIREBOX DEPTH	Width (inches)	Height (inches)	Length (inches)	WATER CONTENT (US-GALLONS)	Draft (inch)	Weight (LBS)
3Wood 4	75,000	14"	24"	38"	21	9	.04	595
3Wood 5	89,000	19"			25	11	.07	695
3Wood 6	104,000	23"			30	12	.10	804
3Wood 7	120,000	27"			34	14	.12	903

LAYOUT OF THE MAIN COMPONENTS

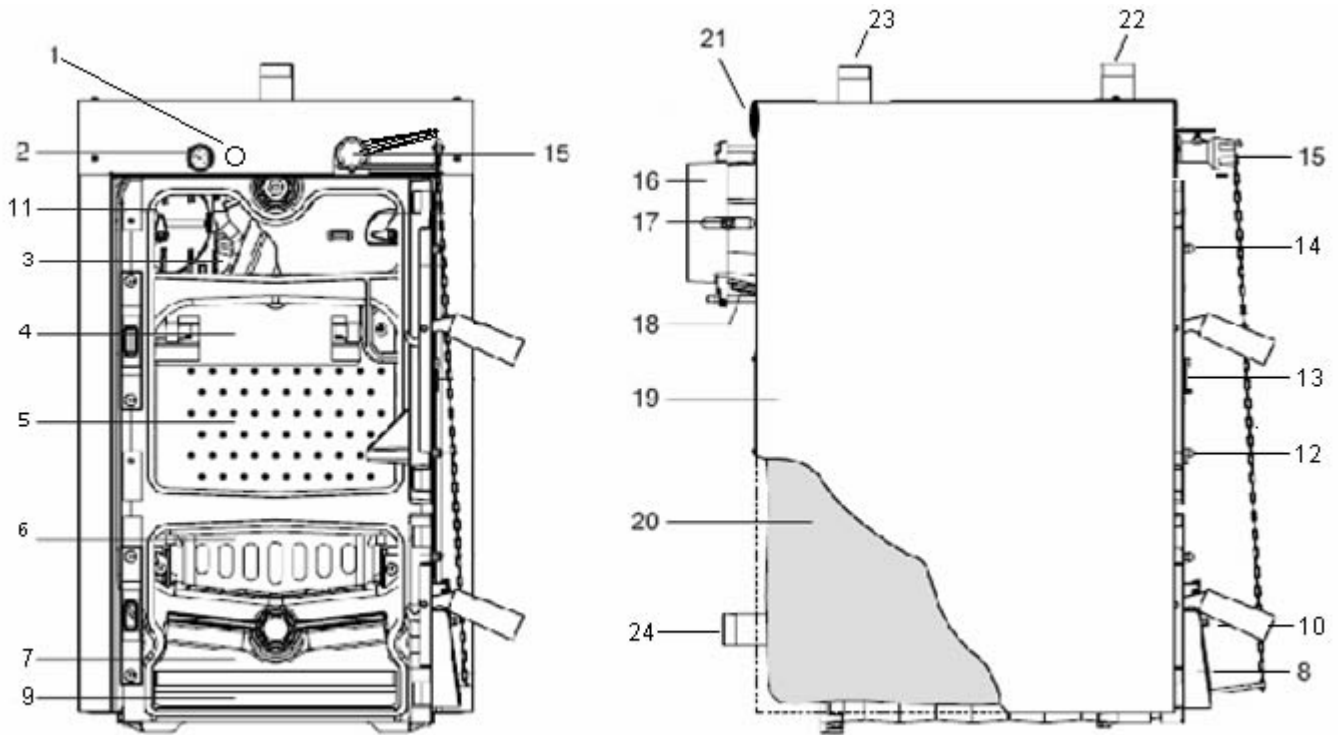

1.	Pressure Gauge	13.	Flame Inspection Window
2.	Temperature Gauge	14.	Loading Door
3.	Flue Gas Chamber	15.	Draft Regulator
4.	Mobile Smoke Plate	16.	Flue Attachment
5.	Loading / Combustion Chamber	17.	Flue Gas Damper
6.	Flue Gas Baffle	18.	Flue Cleanout Door
7.	Ash Collection Chamber	19.	Casing
8.	Ash Pit Door	20.	Insulation
9.	Ash Tray	21.	1 1/2" Flange (Supply Outlet)
10.	Primary Air Damper	22.	1 1/2" Bushing (Pressure Relief Valve)
11.	Secondary Combustion Cover	23.	1 1/2" Bushing (Overheat Control)
12.	Secondary Air Regulator	24.	1 1/2" Flange (Return Outlet)

Transporting

Once the packaging has been removed, cut the straps and remove the casing in such a way as to avoid damaging it.

- If hoisting equipment is available, suitable for the weight of the boiler, use the eyebolts (1) provided on the body to lift it
- If no suitable hoisting equipment is available, handle the boiler manually, as follows:
- Remove the fastening screws (2) for the baseboard (3) and take it off, so as to allow the pallet to be tilted
- Insert a suitably sized bar through the two eyebolts (4) and lift the boiler body.

⚠ WARNING

- Use safety equipment.
- Must be Installed on non combustible floor or cinder blocks extending at least 16" in front and 8" on either side of the 3WOOD.
- Construction of cement block pad under 3WOOD should extend at least 8" to each side of the boiler and extend at least 2" on either side of the chimney connector

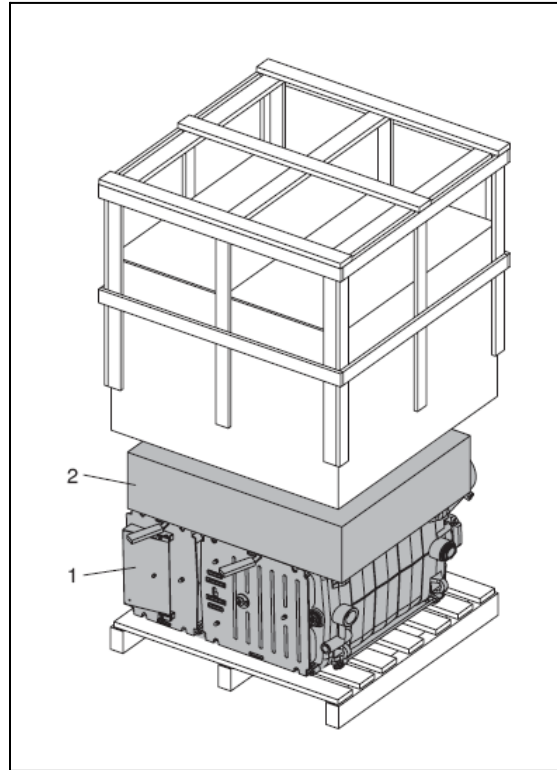

CAUTION

The room where the 3WOOD Boiler is installed must be heated and must always comply with the technical standards and the local codes.

Allow for the space required to access the safety / control devices and to perform the maintenance and loading operations.

- **Do Not** install the 3WOOD appliances:
- Outdoors, as they are not designed for this type of installation.
- In an unheated room.
- In rooms with exhaust fans.
- In houses with heat recovery ventilation systems. (HRV) with out having a outside source of ventilation air for the boiler room.

Recommended Minimum Clearances

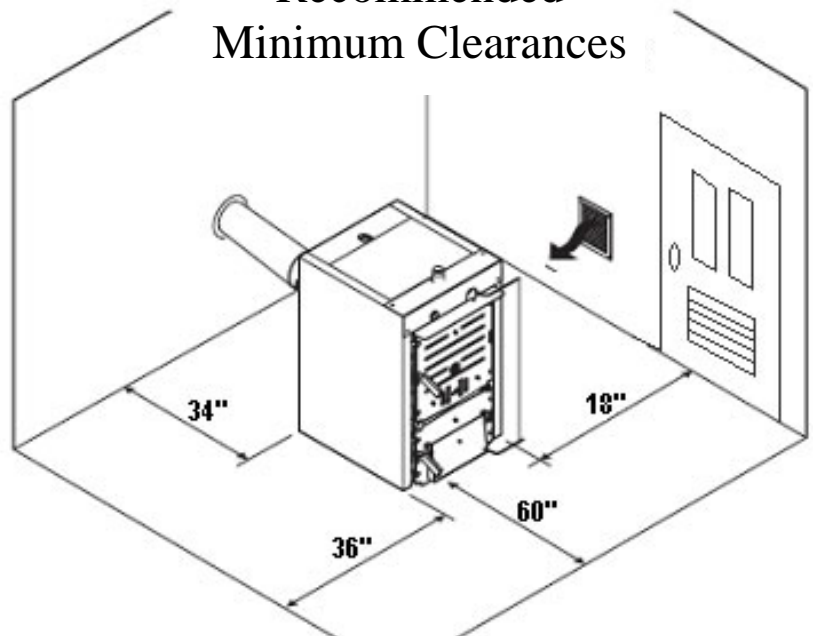



The chimney and flue must be made in compliance with building codes and resistant to high temperature, condensate and mechanical stress, and that are airtight.

- **Do not** connect to any chimney flue or vent servicing another appliance.
- The 3WOOD takes in the combustion air from the room where the boiler is installed, which **MUST FEATURE** ventilation openings as required by NFPA standards.
- The flue (1) must ensure the minimum negative draft between .07 and .12 as specified in the draft section specified on page 17.
- **Undersized or incorrectly sized flues (1) and exhaust pipes (2) will cause problems of condensation, which will affect combustion and plug the flue.**
- The joints should be installed with male ends facing down and sealed using materials that can resist temperatures of at least 700°F.

WARNING

Note: Material of the chimney connector (minimum 24 gauge black or blued steel)

NO GALVANIZED PIPE.

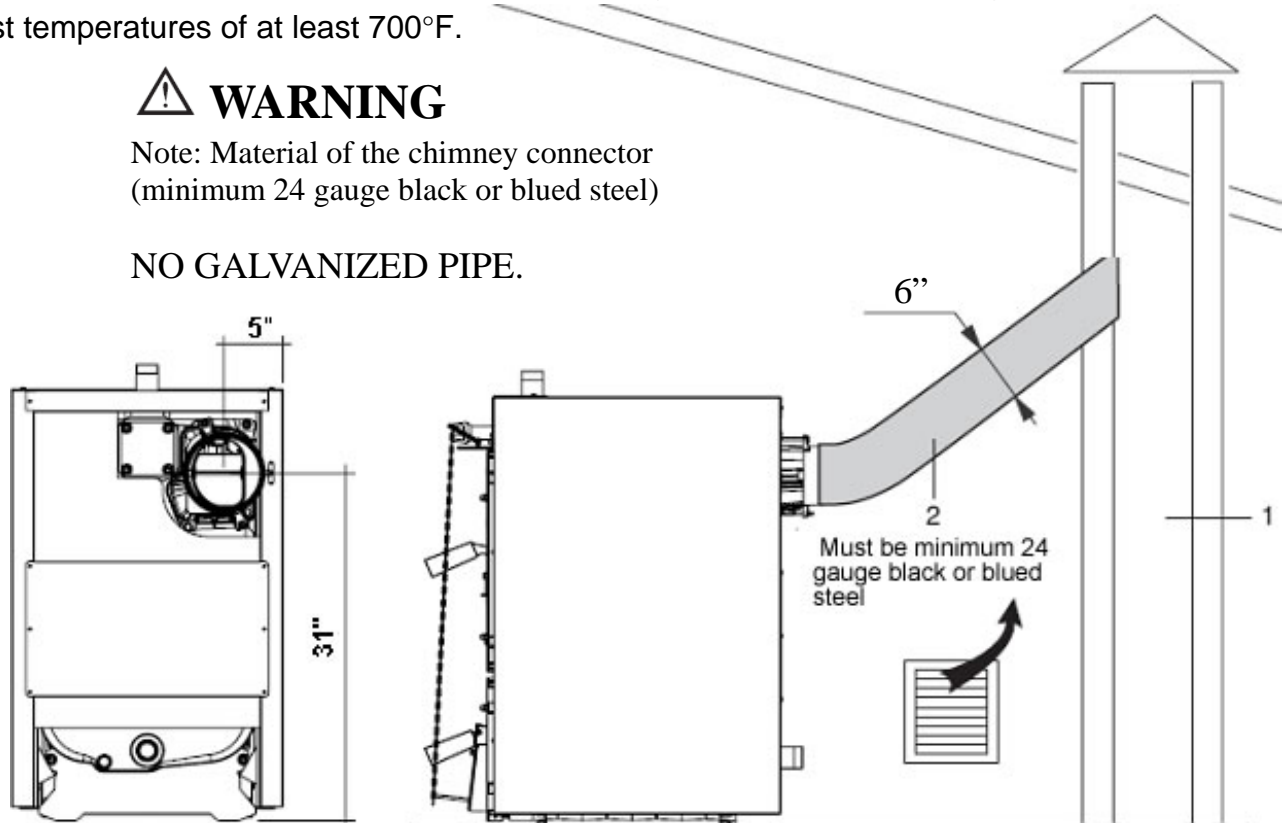

COMBUSTION AIR INTAKE

A separate source of combustion air may be necessary if:

1. The solid-fuel-fired boiler does not draw steadily, smells, experiences smoke roll-out or burns poorly.
2. Any of the above symptoms are alleviated by opening a window slightly on a calm day.
3. The house or basement is equipped with a well-sealed vapor barrier insulation envelope tight fitting windows and/or has any powered devices that exhaust house air.
4. There is excessive condensation on windows in the winter.
5. A ventilation system is installed in the house.

SOURCES OF COMBUSTION AIR ARE:

- A mechanical "Fan in a Can".
- A natural make-up air duct system with heat trap.

ASSEMBLING THE CASING

- A. Remove the outlet and return stubs from the cardboard box inside the loading/combustion chamber, and install them
- B. Fit a screw and nut in the holes on the four bottom brackets (1), without tightening them
- C. Insert them in the top of the four slots provided at the bottom of the boiler, and secure them with the nuts.

NOTE:

The four top brackets (2) have holes for fastening the paneling to the tie-rods

- D. Fit a bolt and nut in the holes on the four bottom brackets (1), without tightening them
- E. Insert them in the four slots at the bottom of the boiler and tighten them
- F. Insert the four top brackets (2) on the studs and tighten them with the nuts (3)
- G. Apply the insulation (4) around the boiler body
- H. Fit the side panels (5), hooking the slots (6) on the bottom of the panels to the bottom brackets (1)
- I. Fasten the panels (6) to the top brackets (2) using the screws (7) supplied with the casing. Leave the right side loose after removing the plug in the top of rear section

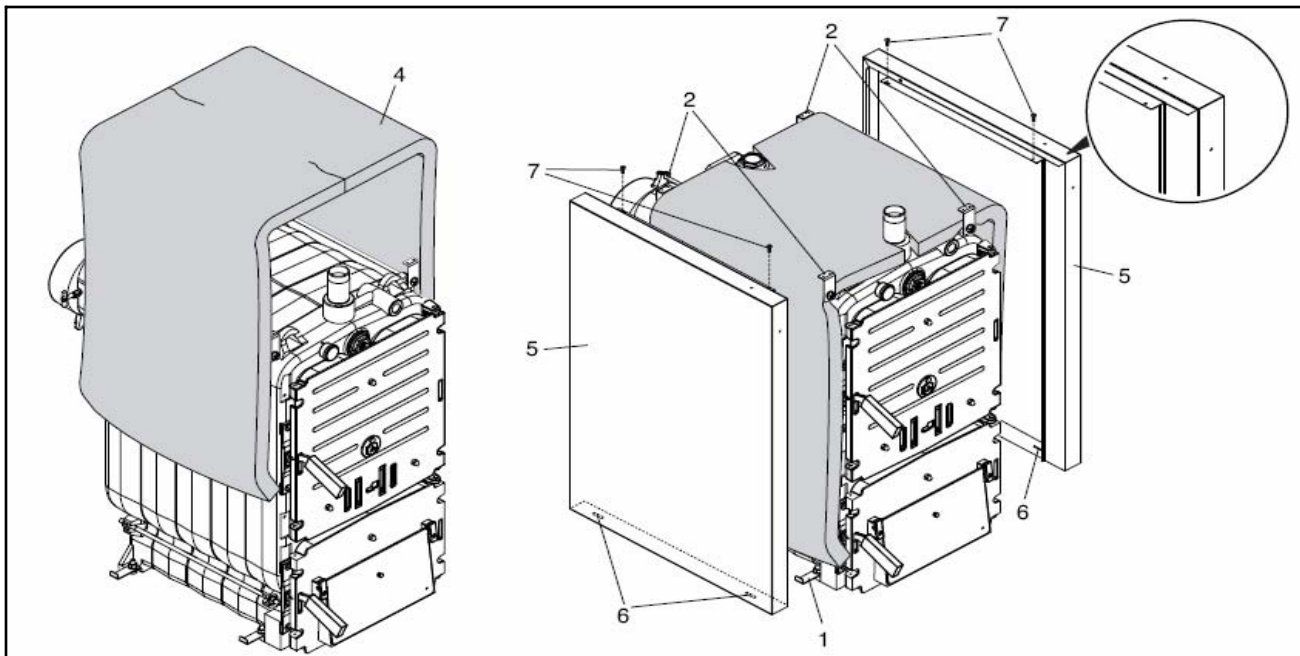
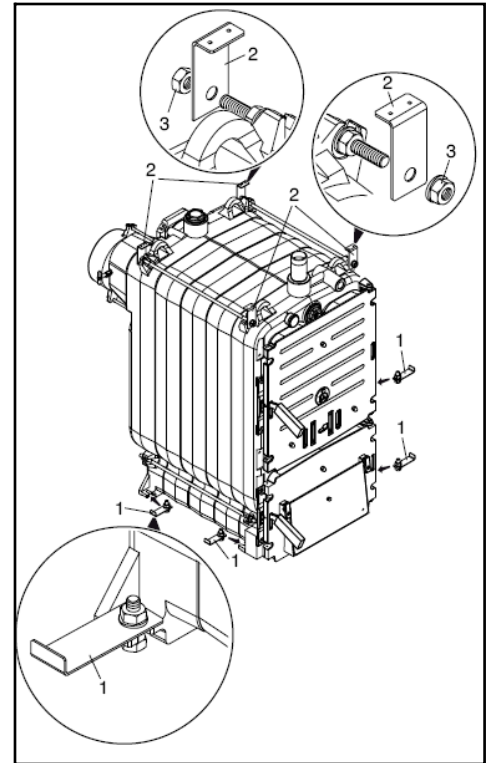

- J. Fit the top rear panel (8), resting it on the side panels, and secure it with two screws (9)
- K. Apply the rear insulation (10), inserting the edges in the openings at the side and top
- L. Fit the rear panel (11) and fasten it with the six screws (12) supplied
- M. Insert the top centre panel (13) underneath the top rear panel (8) and rest it on the side panels

Installation of Controls

- A. Insert the temperature gauge (16) in the housing on the front panel (15) and secure it
- B. Partially unwind the capillary tube from the thermometer, insert the sensor in the probe socket (17) and secure it with the fastening spring
- C. Fit the front panel (15), handling the temperature gauge capillary tube to make sure it is not damaged, and inserting the regulator in the opening provided
- D. Secure it to the side panels using the screws supplied.
- E. Install pressure gauge (13) and capillary tube through the panel and install probe into the flow check/ bushing on the topside rear section of the boiler.
- F. Tighten the draft regulator (14) in the housing provided on the boiler body. The cam w/bolt of the regulator must be in the top position.

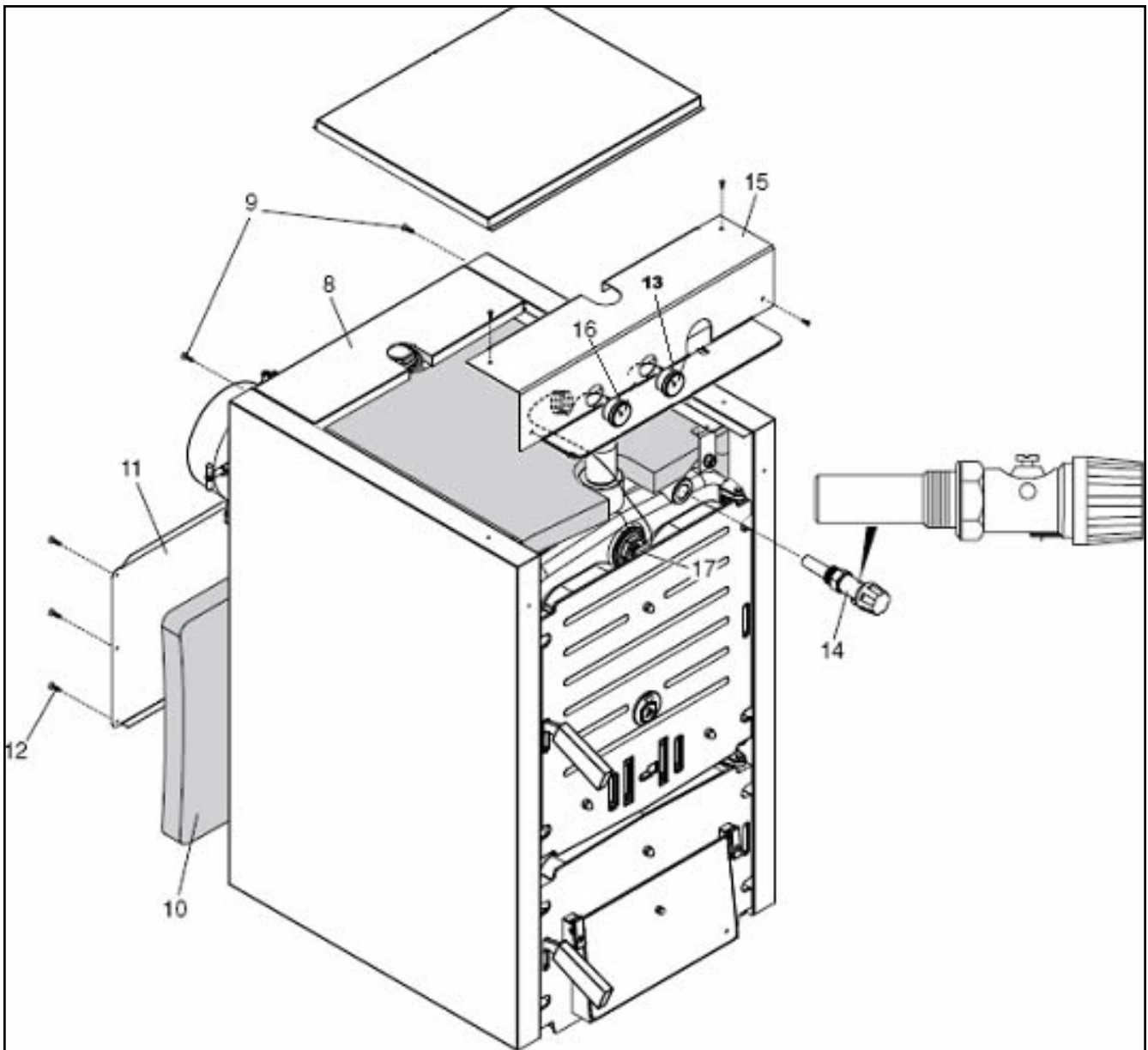

Installation of Flue Gas Partition

- A. Open the loading door (1)
- B. Remove the flue gas cover (2) by turning the latch (3)
- C. Insert the flue gas partition (4) in the guide provided and press it fully into the rear of the boiler.
- D. Replace the cover (2) and secure it with the latch (3)
- E. Open the door on the ash collection chamber (5) and insert the ash tray (6)

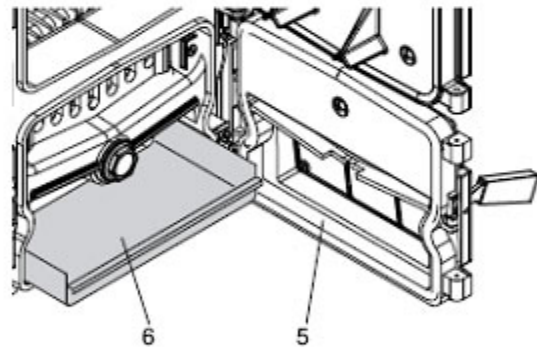
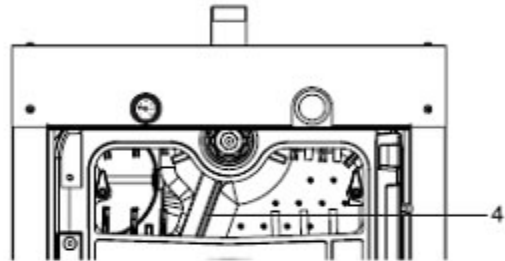
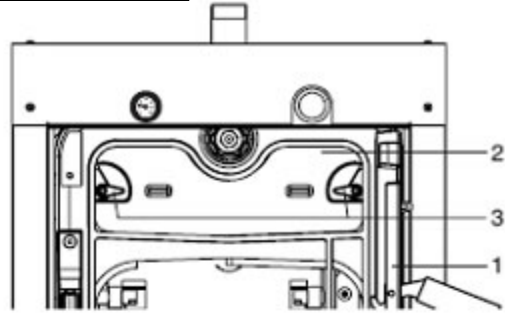

Installation of Draft Regulator

- A. The Samson draft regulator is installed horizontally. The hexagon screw (8) must be at the top.

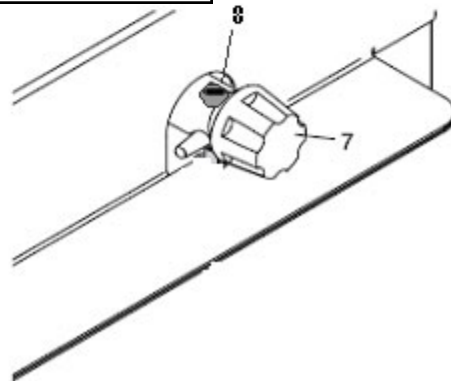

- B. Hold the cam in position by hand, remove the protector (9) and replace it with the hexagonal handle (10) at a 45° angle up from the center of the regulator.
- C. Set the regulator knob (7) by turning knob of regulator counter clockwise to the red 40° mark which is the minimum position (104°F).
- D. Remove chain from bag and cut it 32" long and install the hook and eyelet.
- E. Secure the handle (10) by tightening nut (11) Connect one end of the chain to the hook and attach the hook to handle (10).
- F. Tighten the rod (12) into the threaded hole on the door (must be level with bottom of door) and secure it, using the nut (14), in a horizontal position so the end of rod is facing to the right
- G. Attach the 2nd hook to the other end of the chain and connect it to the end of the rod (12). In this position the air door (13) is fully open.

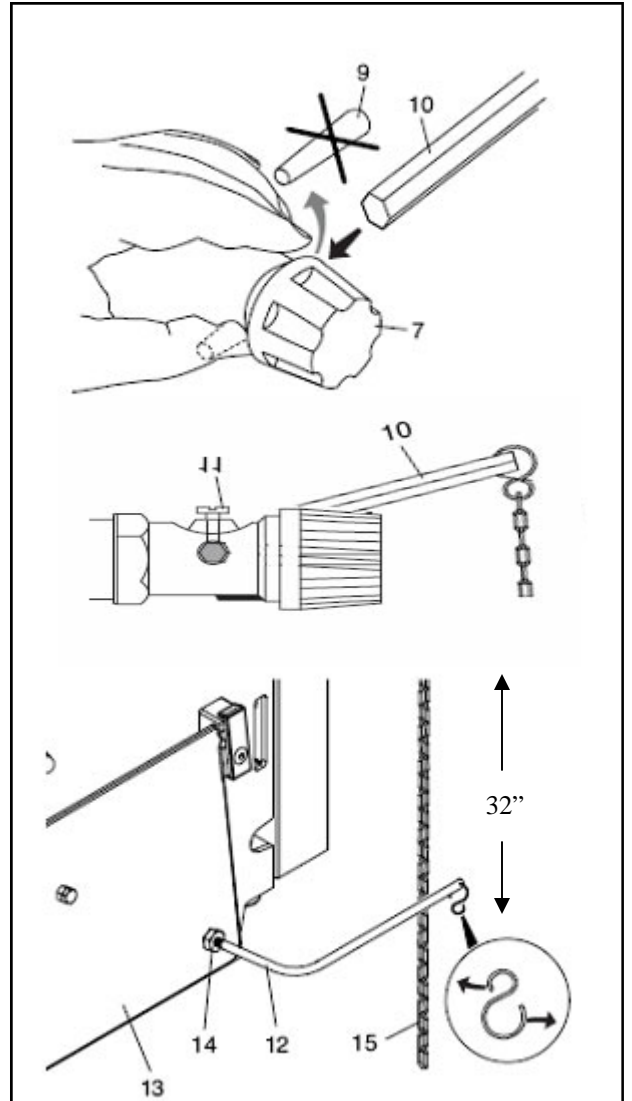

CAUTION

NOTE:
Chain must be exactly 32 inches long.

IMPORTANT:

When assembly has been completed, the Heating Contractor must make sure that the **TECHNICAL RATING PLATE** is attached to the casing.

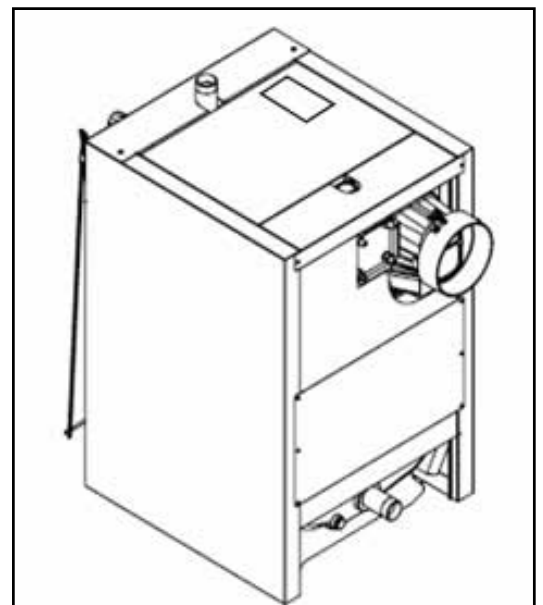

WARNING

PRELIMINARY CHECKS/ Starting The Fire

Before starting a fire in the 3 WOOD, check that:

1. The 3WOOD is filled with water.
2. The valves are open in the distribution system.
3. The distribution system has been purged of all its air.
4. The exhaust pipe and combustion air controls and dampers have been installed correctly.
5. The seals on flue and ash door are in good condition.

STARTING AND MAINTAINING A WOOD FIRE

- A. Completely open the flue gas damper (1) (horizontal position) on breaching.
- B. Turn draft regulator knob clockwise to the red mark 90°C
- C. Move the secondary air regulator (3) to the middle position
- D. Adjust the primary air damper (4) so it is open 1/32" at the bottom (minimum opening) using the screw (5). Lock it in place with the lock nut. The regulator arm should be in a level position.

Note: Never detach the chain from the rods or the handle.

- E. Open the loading door (6), place small pieces of paper and dry kindling wood on the top of the grates and ignite them
- F. Wait for kindling to ignite, complete the load with larger pieces of wood not higher than bottom of flap, then close the loading door (6)
- G. Ensure the boiler has adequate combustion air from vents to the boiler room. Air can be taken from basement brought in from the outside.

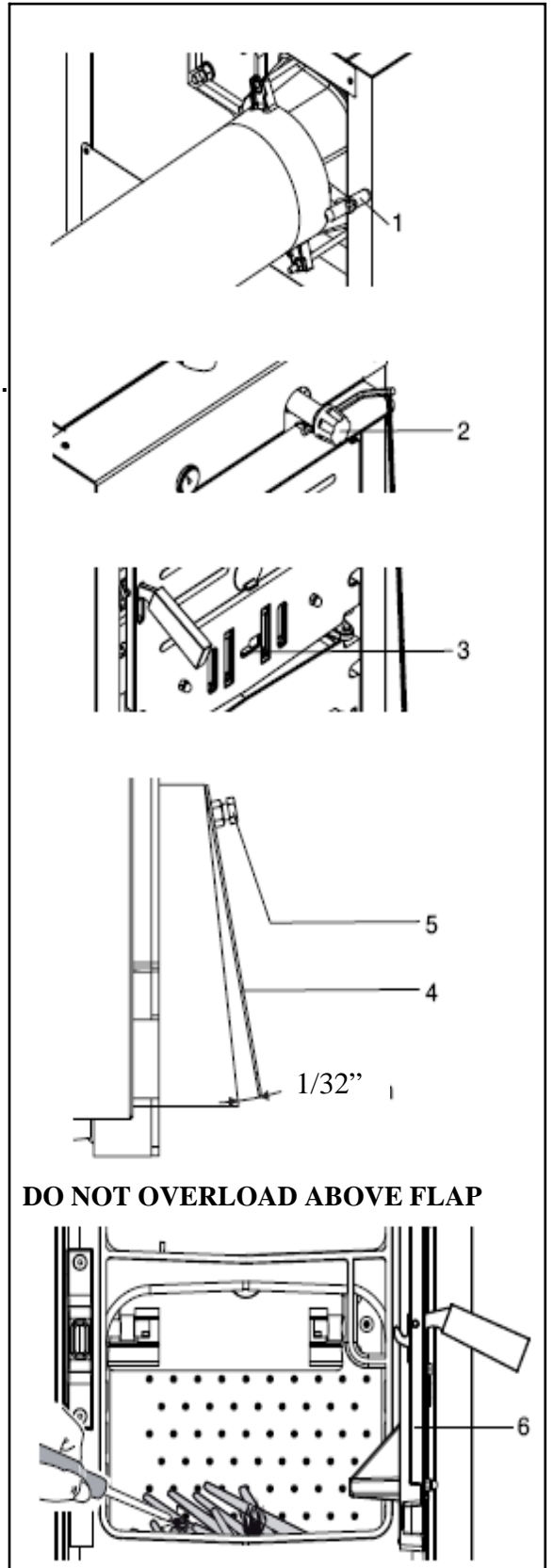

Before choosing a particular system for your installation, the possibility of using a mixing valve arrangement to avoid the problems of overheating should be considered. These systems will continuously release heat to the distribution system in proportion to the outside temperature or other load factor. Such an arrangement can be added to any heating system, and is one of the most sophisticated methods of heating system regulation available. We strongly recommend a mixing system with all of our solid fuel systems.

A. 3WOOD AS THE ONLY BOILER

The **3WOOD** boiler can be used as the only boiler in your heating system. Of course, the disadvantage of the installation is that there will be no automatic back-up system for times when the solid fuel fire will be unattended. For automatic switch-over from solid fuel to oil or gas, a tandem hookup of the **3WOOD** with a second oil or gas boiler is recommended (see Section B). The obvious advantage of this set-up is the cost saving involved in the elimination of the conventional boiler, controls and piping required. It should be noted that the **3WOOD** boiler is extremely efficient when fired with wood or coal. Many people use the **3WOOD** boiler in conjunction with direct vent gas or electric space heaters located in the living spaces.

The following outlines a typical installation of a stand-alone **3WOOD** boiler in a system planned for solid fuel firing.

1. The supply tapping goes to the heating radiation. Install a “tee” with a 1” branch in the line to the radiation, as close to the boiler as possible. This branch tee should point up and will route the piping to the “dump zone”. There must not be a valve or any potential restriction between the boiler and this tee.
2. In the boiler supply piping, install an air purger and expansion tank sized to handle the water in the distribution system as well as the **3WOOD** boiler.
3. Pipe the make-up water into the boiler through a Watts 1156F fill valve (pressure reducing valve) into the lower rear ½” tapping at the bottom of the boiler.
4. Install a tee with a 1” branch for the dump zone in the return tapping. Point the branch of the tee up.
5. The circulator should be installed in the return line from the heating radiation. The return is piped into the boiler through the running end of the tee.
6. A circulator relay, Honeywell R845 or equivalent may control the circulator. Both the room thermostat and the Overheat Aquastat installed in the **3WOOD** boiler control this relay.

NOTE: In a case where the thermostat is calling for heat and boiler fire is out or otherwise unable to meet the heating demands of the house, the circulator will continue to run. This has the advantage of helping prevent the water in the system from freezing if the house temperature drops below 32F. **If the circulator is deactivated, the system must be drained if subfreezing interior temperatures are anticipated!** As an alternative to draining the system, a mixture of heating system, anti-freeze (propylene glycol) and water can be used in place of normal water in the system. Such a mixture should only be added after the system is thoroughly checked for leaks.

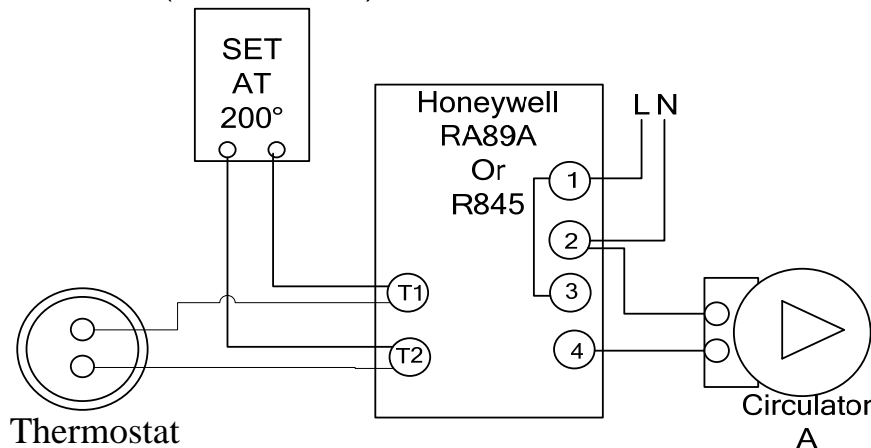
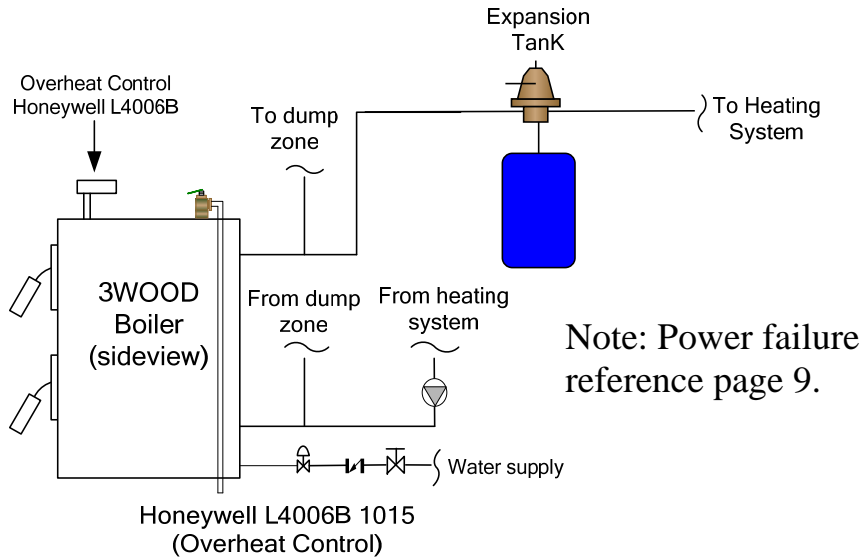

NOTE: All wiring must be done in accordance with applicable state, local and national codes. Use only copper conductors.

3Wood installed in combination with a oil/gas boiler

Note: The operation of the gas boiler must be verified for acceptable operation before and after installation of the add-on appliance by a gas fitter who is recognized by the regulatory authority.

PIPING NOTES:

⚠ CAUTION

1. This drawing is meant to show system piping concept only.
2. The installer is responsible for all equipment & detailing required by local codes.
3. Discharge of Pressure Relief Valve must be piped without valves to within 3" of the floor.
4. Where required, Low Water Cutoff must be installed in the Supply piping of the oil/gas boiler.
5. **DO NOT** interfere with the normal delivery of heated water from the original boiler to the system.
6. Make sure that excessive pressure will not be developed in any portion of the boiler or system through properly sizing the expansion tank.

B. 4-WAY MIXING VALVE Installed with 3WOOD Boiler in Combination with Oil/Gas Boiler

1. A mixing valve arrangement is a method of controlling house temperature that is different than traditional American systems. In the average hydronic system, circulating or not circulating water of a fairly high and relatively constant temperature to radiation controls temperature in the house or zone. The thermostat used in such a system is a simple switch to a relay, which turns the circulator on and off. In a mixing valve controlled system, the circulator runs continuously, and the temperature of the water flowing to the house is varied by the mixing valve, which adds more or less cooler return water to the boiler-heated, water being pumped to the radiation. The valve is controlled manually by the homeowner (a very common system in Europe), or is controlled automatically by an outdoor reset control.

A system controlled by a mixing valve has several advantages over a conventional off/on system.

- Fuel savings of 20%
- Longer boiler life due to elimination of thermal shock to the boiler caused by surges of cold return water at circulator start-up
- A quieter and more comfortable house, because heat is more even. Rather than having the heat turn completely on and completely off in response to heating demands, causing fluctuation in the house temperature, the heat is always “on” with the temperature of the radiation adjusting gradually to respond to the house’s needs.

In addition, a mixing valve arrangement has very important advantages for solid fuel burning hot water systems. Because there is constant circulation, there is always some heat being drawn from the boiler. Since a solid fuel is always generating a certain amount of heat, such a system will dispose of this heat efficiently. In conventional system, there is a greater possibility of the boiler overheating (when there is no circulation) and creosote formation (caused by the fire burning too slowly). A mixing valve system minimizes the possibility of either of those problems occurring, thus increasing both the safety and efficiency of the solid fuel system.

Mixing valve arrangements can be added to any of the systems described in this section or, in fact, to any conventional heating system as well. We recommend the 4-way mixing valve to control the temperature of the heating radiation. To mix wood heated boiler water with the return water from the distribution system, the boiler supply pipe must enter the mixing valve opposite the heating return pipe.

The following outlines a typical installation of a mixing valve controlled distribution system with a 3WOOD boiler in a system planned for solid fuel firing with back-up from a oil or gas-fired boiler.

1. The line from the **3WOOD** boiler supply tapping goes to the oil/gas boiler return tapping. Install a “tee” with a 1” branch in the line as close to the **3WOOD** boiler as possible. This branch tee should point up and will route the piping to the “dump zone”. There must not be a valve or any potential restriction between the boiler and this tee.
2. Immediately after the “dump-zone” tee, install another tee with a ½ inch branch to install the L4006B aquastat to operate the **3WOOD** circulator
3. In the boiler supply piping install an air purger and expansion tank sized to handle the water in the distribution system as well as the **3WOOD** boiler.
4. Pipe the make-up water into the **3WOOD** boiler and the oil/gas boiler through a Watts 1156F fill valve (pressure reducing valve) into the lower rear ½” tapping at the bottom of the **3WOOD** boiler and also into the oil/gas boiler.
5. Install a tee with a 1” branch for the dump zone in the return tapping as close to the **3WOOD** boiler as possible. Point the branch of the tee up.
6. The **3WOOD** boiler circulator should be installed from the other pipe-leg of the tee to the supply tapping of the mixing valve from the supply tapping of the gas/oil boiler. This circulator line is piped into the **3WOOD** boiler from the circulator through a flow check, then running end of the “dump-zone tee and finally into the return tapping of the **3WOOD** boiler.
7. The **3WOOD** boiler circulator may be controlled by an outdoor reset controller operating the mixing valve, the oil/gas boiler or circulator relay or a Honeywell R89 or R845 or equivalent if the mixing valve is manually operated. This relay is controlled by both the **3WOOD** boiler Aquastat and the Overheat Aquastat installed in the **3WOOD** boiler.

4 Way Mixing Valve Piping

(Circulators, Controls, Valves & Wiring for 3 WOOD, Boiler supplied by others.)

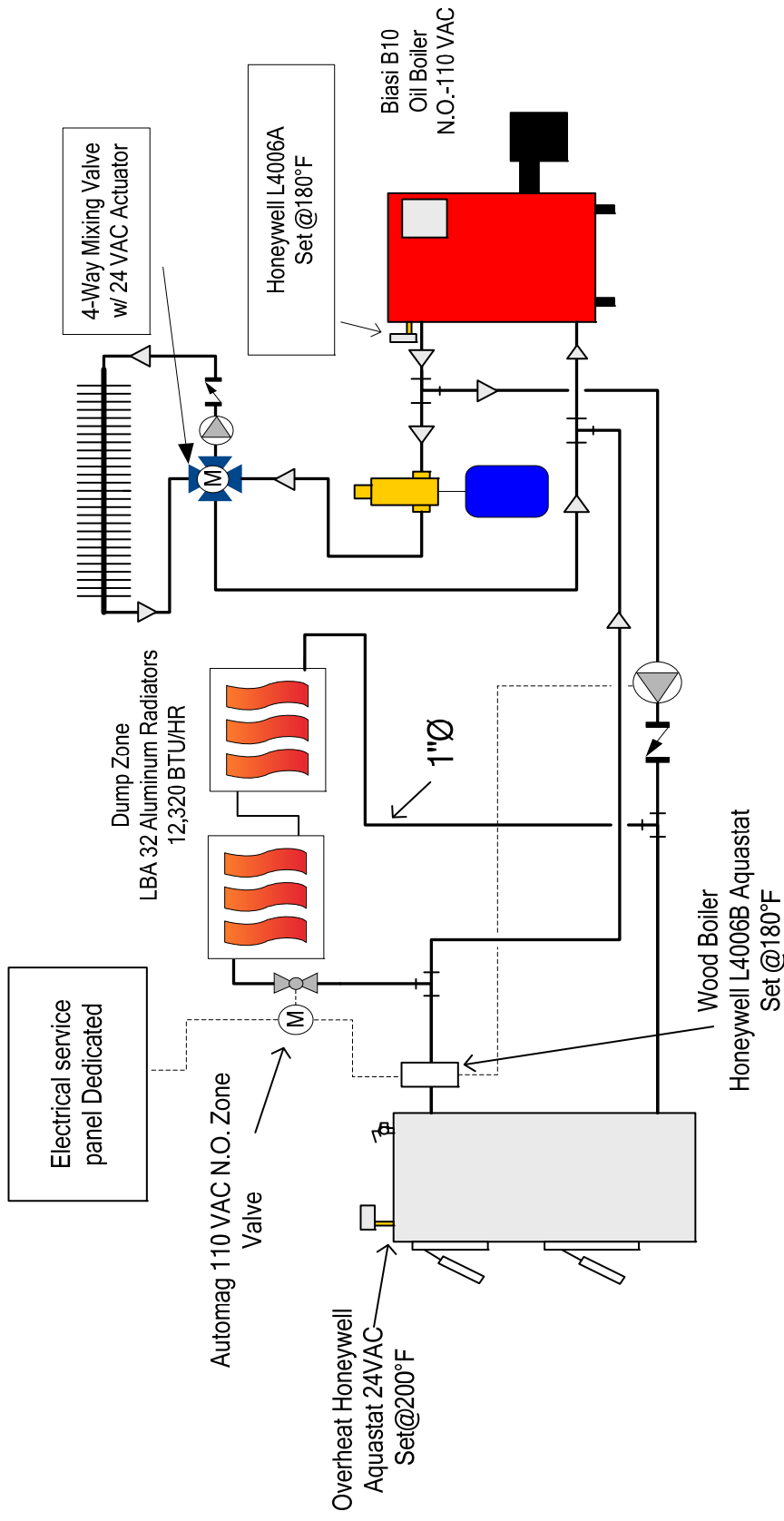

PIPING NOTES:

1. This drawing is meant to show system piping concept only.
2. The installer is responsible for all equipment & detailing required by local codes.
3. Discharge of Pressure Relief Valve must be piped without valves to within 3" of the floor.
4. Where required, Low Water Cutoff must be installed in the Supply piping of the oil/gas boiler.
4. The 3WOOD boiler must not interfere with the normal delivery of heated water from the original boiler.

C. **3WOOD Boiler** with circulator **Piped in Parallel with Oil/Gas Boiler**

In the traditional American baseboard, hydronic system, the heating temperature in the house or zone is controlled by circulating or not circulating water of a fairly high and relatively constant temperature to radiation. The thermostat used in such a system is a simple switch to a relay which turns the circulator on and off. The vast majority of American heating systems use cast iron boilers which have internal tankless coils for producing domestic hot water. The parallel piping arrangement is the correct application for maintaining temperature in the oil/gas boiler with wood heated hot water as well as heating the radiation in the house. Since the specifics of such a system will vary from installation to installation, the following procedure provides an example of one specific installation which can be used as a model for actual situations.

1. Insure that the existing system has flow checks or electric zone valves in the supply lines to the various heating zones, and that the Space heat and DHW circulators are mounted on the return line going back to the Oil/Gas boiler. If not, they must be installed in these locations.
2. Remove the existing radiation supply and return lines from the oil or gas-fired boiler. Install pipe tees on the supply and returns from nipples coming out of the existing oil/gas boiler. **NOTE:** Occasionally, extra supply and return taps are available on oil/gas boilers. These plugs may be removed and used to run the lines between boilers. Re-install the supply and return lines.
3. Install a tee with a 1" branch coming out of the supply tapping of the **3WOOD** boiler for the dump zone.
4. Then install another tee with a ¾" branch for the Aquastat for the **3WOOD** boiler's circulator. Install the Honeywell L4006B into the branch of the tee using the ¾" immersion well. **Caution: Be careful to maintain a 12" minimum clearance between the flue pipe and the 3WOOD boiler aquastat.**
5. Pipe from this tee down to the return tee or tapping on the existing oil/gas boiler.
Note: By adding the gallonage from the addition of the **3WOOD** boiler, an expansion tank should be added or the existing tank should be increased in capacity.
6. Install a tee with a 1" branch coming out of the return tapping of the **3WOOD** boiler for the dump zone.
7. Install piping, flow check and circulator from **3WOOD** boiler to the supply tee installed on the oil/gas boiler.

Note: Aquastat settings for the existing oil/gas boiler should be as follows:

High Limit – 165F

Low Limit - 150F

Circulator - 140F

But these settings can be raised if the **3WOOD** boiler isn't fired for extended periods of time.

Parallel Piping

(Circulators, Controls, Valves & Wiring for 3 WOOD, Boiler supplied by others.)

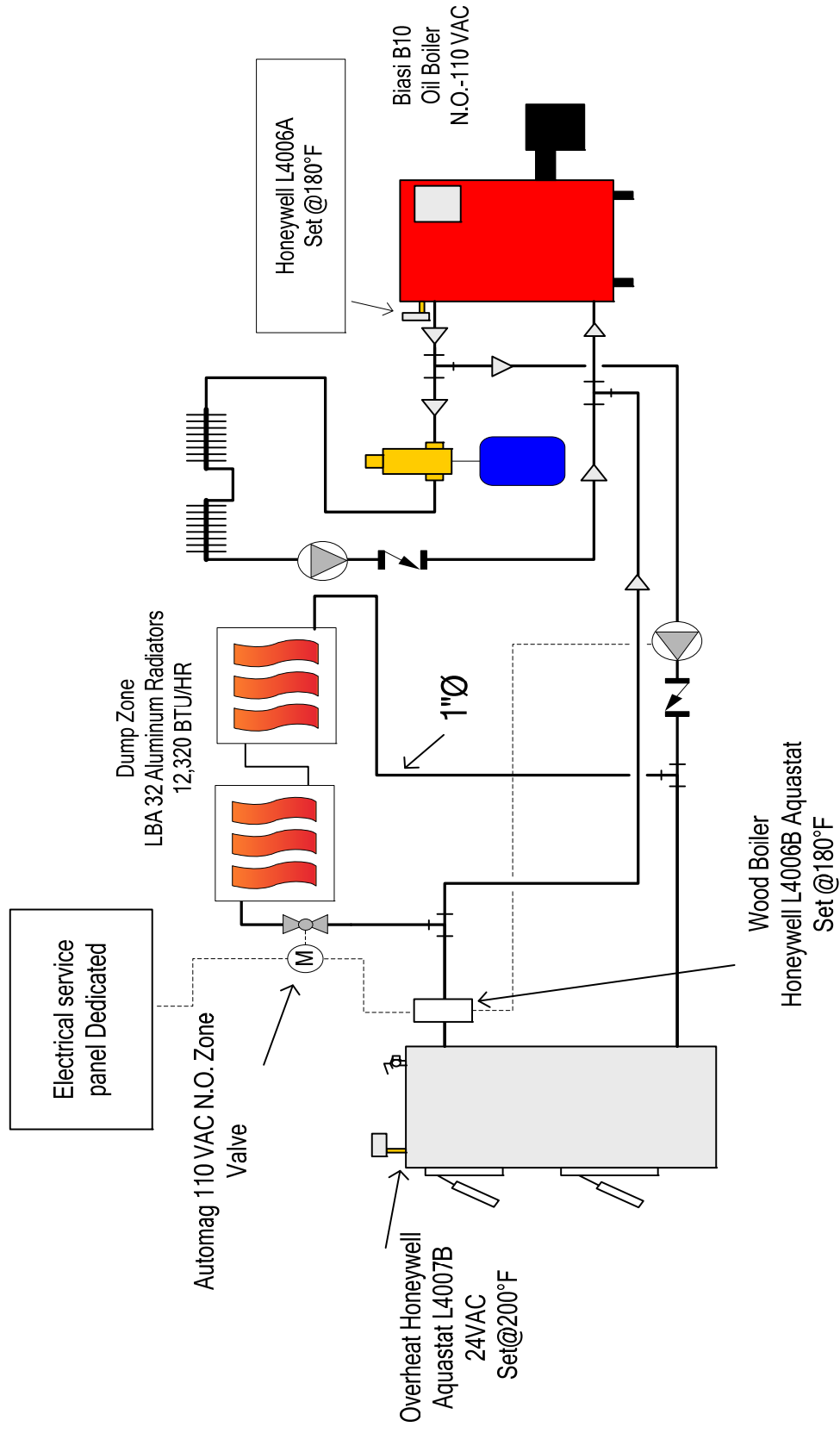

PIPING NOTES:

1. This drawing is meant to show system piping concept only. The installer is responsible for all equipment & detailing required by local codes.
2. Discharge of Pressure Relief Valve must be piped without valves to within 3" of the floor.
3. Where required, Low Water Cutoff must be installed in the Supply piping of the oil/gas boiler
4. The 3WOOD boiler must not interfere with the normal delivery of heated water from the original boiler.

Parallel Piping

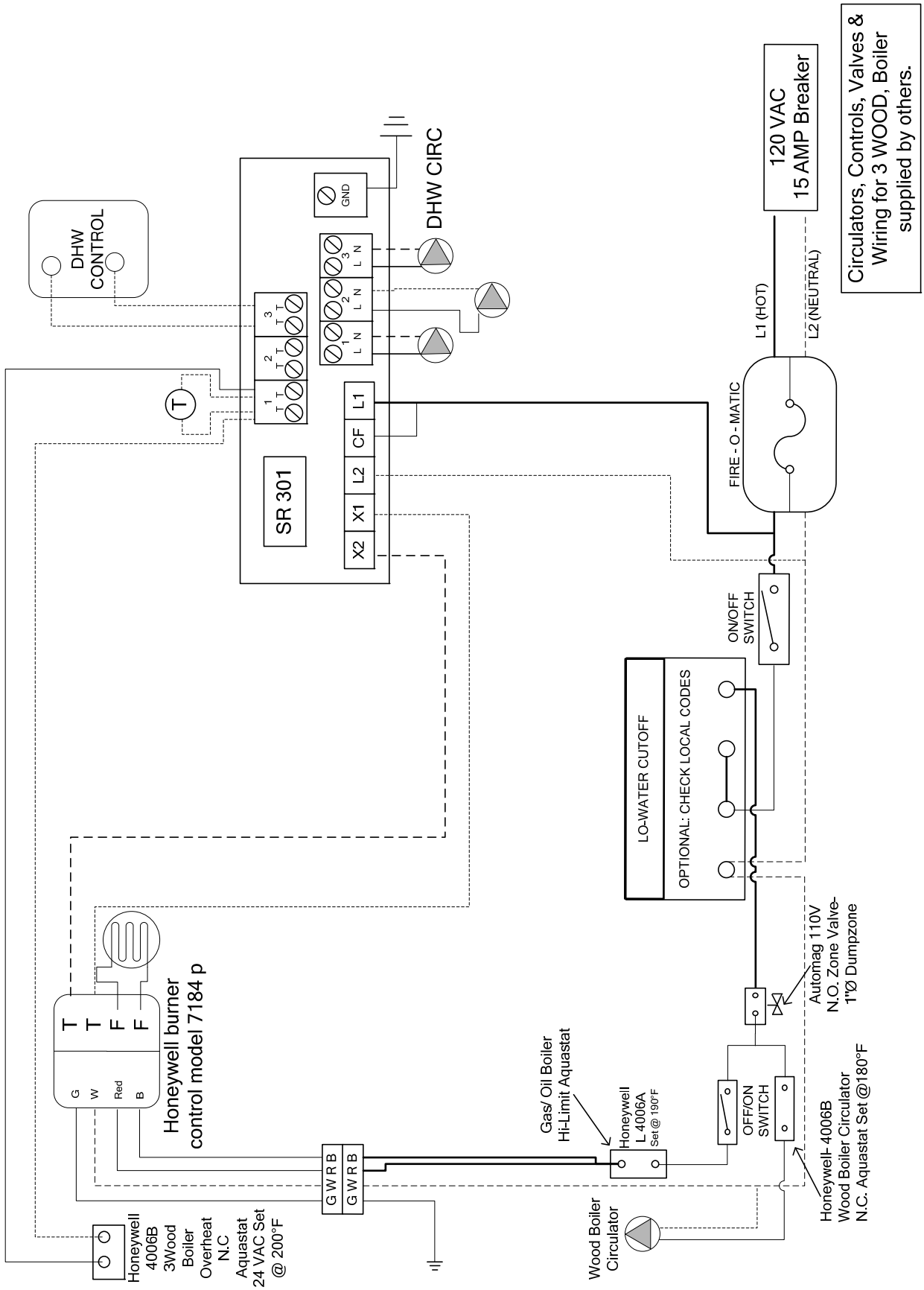

Circulators, Controls, Valves & Wiring for 3 WOOD, Boiler supplied by others.

NOTE: All wiring must be done in accordance with applicable state, local and national codes. Use only copper conductors. The 3WOOD must be installed without changing the function of the controls or rewiring the original boiler. A wiring interconnection is permitted. The electrical system of both boilers shall be powered from a single branch circuit without exception.

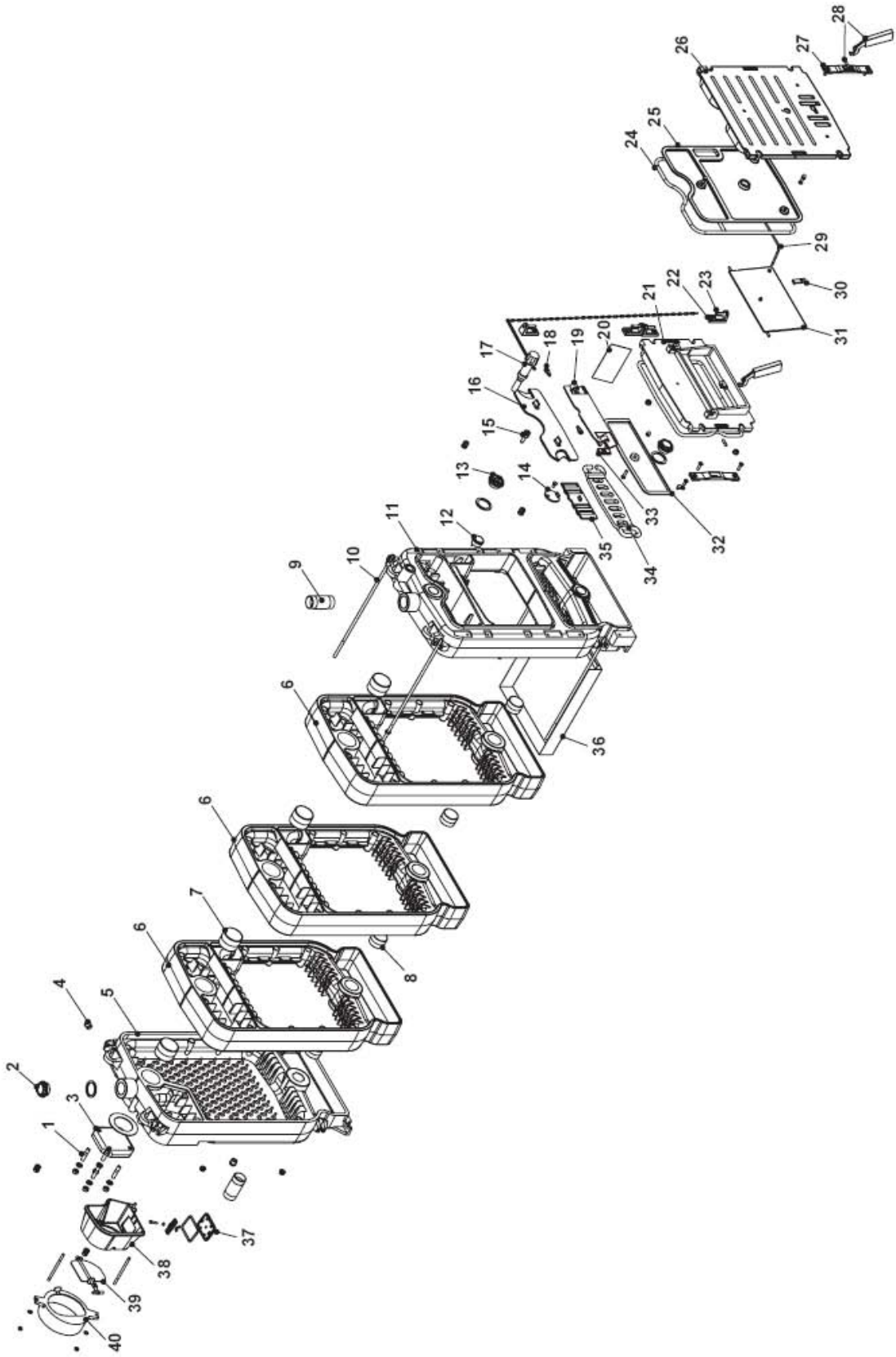

#	Description	3WOOD 4,5,6,7
1	Stud Screw	59200619
2	Bushing	59200620
3	Flange	59200621
4	Side Tapping	
5	Rear Boiler Section	59200623
6	Intermediate Boiler Sections	59200624
7	Top Push Nipples	59200625
8	Bottom Push Nipples	59200626
9	Bushing	59200627
10	Tie Rod	59200628,59200629 59200630,59200631
11	Front Boiler Section	59200632
12	Temperature Gauge	59200633
13	Bushing	59200634
14	Inspection Port	59200635
15	Immersion Well	59200636
16	Flue Gas Baffle	59200637
17	Draft Regulator	59200638
18	Flue Gas Baffle Lock	59200639
19	Plate	59200640
20	Partition	59200641,59200641 59200642,59200643

21	Bottom Door	59200644
22	Hinge	59200645
23	Pin	59200646
24	Gasket	59200729
25	Flame Guard	59200647
26	Top Door	59200648
27	Handle Catch	59200649
28	Handle Catch	59200650
29	Regulator	59200651
30	Lower Door Stop	59200652
31	Air Baffle	59200653
32	Flame Guard	59200654
33	Upper Door Stop	59200655
34	Load Door Grille	59200656
35	Secondary Air Grille	59200657
36	Ash Tray	59200658,59200659, 59200660,59200661
37	Flue Collar Clean-Out	59200662
38	Flue Collar Spacer	59200663
39	Flue Damper	59200664
40	Flue Collar	59200665

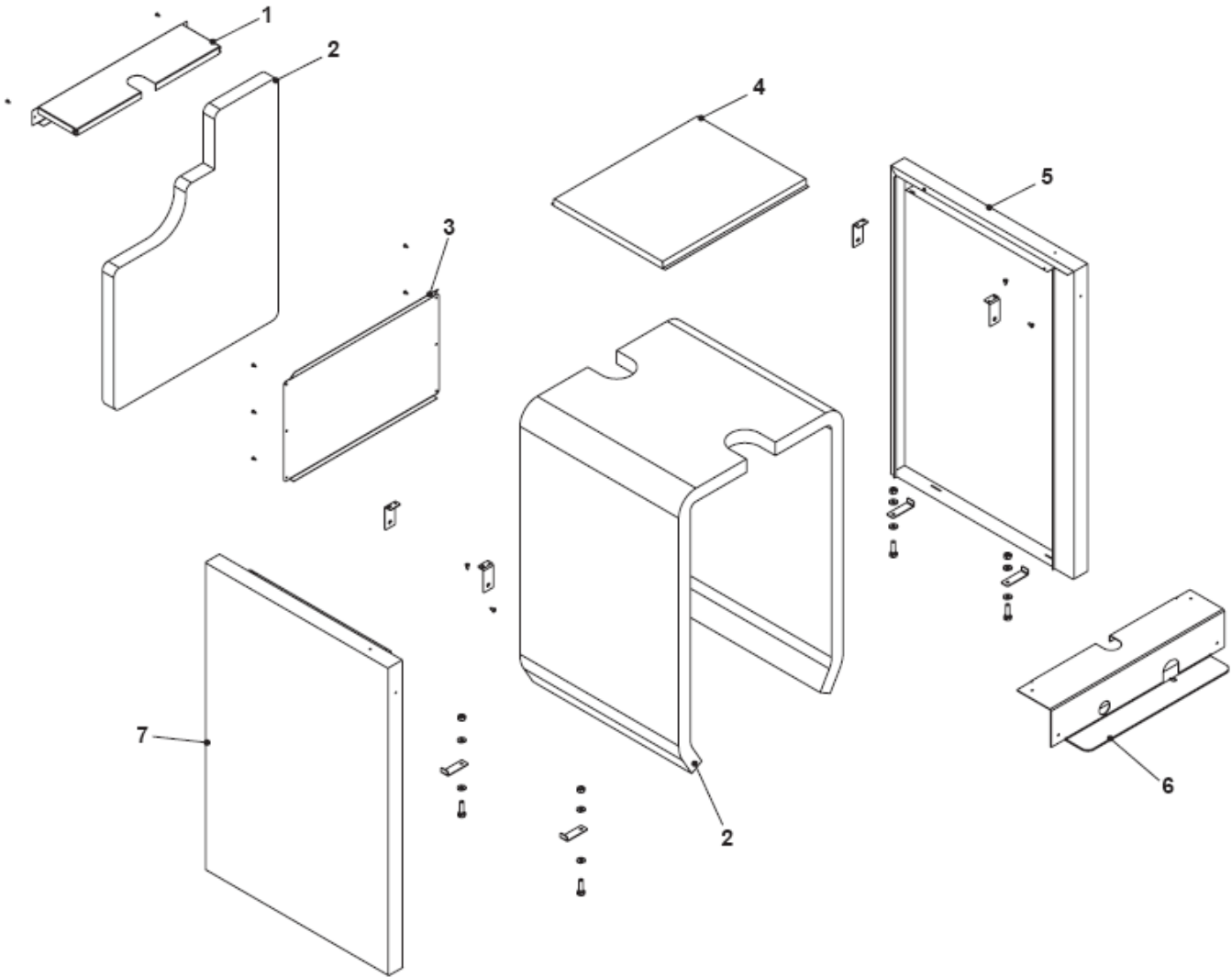

#	Description	3WOOD-4	3WOOD-5	3WOOD-6	3WOOD-7
1	Top Rear Panel	59200600	59200600	59200600	59200600
2	Insulation Assembly	59200601	59200602	59200603	59200604
3	Rear Panel	59200605	59200605	59200605	59200605
4	Cover Panel	59200606	59200607	59200608	59200609
5	Right Side Panel	59200610	59200611	59200612	59200613
6	Front Panel	59200614	59200614	59200614	59200614
7	Left Side Panel	59200615	59200616	59200617	59200618

Extended Shutdown:

If the boiler is not used for an extended period, the following operations must be performed:

- Close the on-off valves connected to the 3WOOD Boiler.
- Remove the ash and clean the flue gas path.
- Assess whether the Technical Service needs to be contacted for more through cleaning.

WARNING

- Empty the system or add Non-Toxic antifreeze fluids to the heat system if there is danger of frost.
- A container with powdered lime should be placed inside the boiler to absorb humidity.

Maintenance:

Periodical maintenance is a legal requirement and is essential for the safety, efficiency and life of the 3WOOD Boiler.

It must be performed by a qualified heating contractor at least once a year so as to clean the entire flue gas path : loading/combustion chamber, smoke box and flues.

Routine Cleaning:

Before starting any cleaning operations wait for the boiler to cool down.

External Cleaning:

The casing can be cleaned using cloths dipped in soap and water.

For hard-to-remove stains, dip the cloth in a mixture of 50% water and denatured alcohol or other specific products. Once finished cleaning, carefully dry the 3WOOD Boiler.

WARNING

- Do not use abrasive products, petrol or trichloroethylene.
- Always make sure there are NO hot coals underneath the ash.
- Use suitable safety equipment.
- The boiler is supplied without accessories, as cleaning can be performed using normal household utensils that can be purchased at shops that sell products for stoves and fireplaces.

Problem	Cause	Corrective action
There is a smell of fumes.	- Fumes are escaping into the air	- Clean and check the tightness of the flue gas path - Check that the loading and combustion chamber doors close correctly
	- Draft Regulator	- Check correct operation and replace if necessary
	- Chain unhooked or broken	- Hook chain or replace it
	- Primary air regulator damper jammed	- Release the damper
	- Load wood	- Follow the procedure described in this manual
	- Flue gas damper	- Check and adjust the position, if necessary
The boiler has reached the set temperature but the radiators are still cold.	- Air in the system	- Vent the system
	- System components	- Check valves, pumps, room. Thermostats. Take and necessary action where required
	- Float valve in the open expansion vessel	- Check operation and replace if necessary
The boiler does not reach the set temperature	- Draft regulator	- Check operation and replace if necessary
	- Chain unhooked or broken	- Hook the chain back on or replace
	- Primary air regulator damper jammed	- Release the damper
	- Flue gas path and/ or boiler dirty	- Clean the flue gas path - Clean the boiler
	- Load wood	- Follow the procedure described in this manual
	- Flue gas damper	- Check and adjust the position, if necessary
Flue gas emissions dark in color	- Flue blocked - Boiler dirty - Ash tray full	- Clean the flue gas path - Clean the boiler - Empty and clean the ash tray
	- Air adjustment	- Check the correct operation of the draft regulator - Check chimney draft - Check the position of flue gas damper and adjust it if necessary
	- Draft regulator	- Check correct operation and replace if necessary
	- Unseasoned wood	- Use seasoned wood (12-20% UR)
	- Load wood	- Follow the procedure described in this manual

Boiler Model No. _____

Serial No. _____

Original Purchaser:

Installer:

Boiler Performance Tests:

GROSS STACK TEMPERATURE -----

ROOM TEMPERATURE (AMBIENT) -----

NET STACK TEMPERATURE -----

CO2 -----

O2-----

SMOKE READING -----

COMBUSTION EFFICIENCY-----

COMMENTS:

Warranty for BIASI - 3WOOD Residential Cast-Iron Water Boilers

FIRST YEAR-WARRANTY FOR 3WOOD SERIES

RESIDENTIAL HOT WATER BOILERS: QHT warrants that its cast-iron boiler and casing are free from defects in material and workmanship for one year from the date of installation. If the boiler is found to be defective within this period, QHT will replace the boiler block or casing.

LIFETIME WARRANTY-WARRANTY FOR THE CAST IRON BOILER BLOCKS OF THE 3WOOD SERIES RESIDENTIAL BOILERS:

Biasi warrants that the cast-iron sections and nipples of the BIASI 3WOOD boilers are free from defects in material and workmanship for the lifetime of the original single family home installation. If the 3WOOD boiler block is then found to be defective, QHT and Biasi will replace the original cast iron boiler block.

These warranties are subject to the condition that a heating contractor whose principal occupation is the sale and installation of heating equipment must have installed the boiler.

PARTS, WHICH ARE COVERED, consists of all materials supplied by Biasi, identified by QHT's part numbers in its literature. Other parts supplied in the casing, trim kit or in the burner pack carry their own warranty and each manufacturer has responsibility for its own products.

NOTE: ANY PART, WHICH IS REPLACED UNDER WARRANTY, CARRIES ONLY THE UNEXPIRED PORTION OF THE ORIGINAL WARRANTY.

OWNER RESPONSIBILITIES:

1. Provide for proper installation, which includes pressure relief and pressure reducing valves and high limit safety controls on closed systems.
2. Provide qualified periodic service to prolong proper operation and service.
3. Insure that boiler is installed with approved burner and that installation conforms to all codes and ordinances.
4. This warranty does not apply to boilers, which are subject to misuse, abuse, neglect, alteration, accident, excessive temperature, excessive pressure, or corrosive water or atmosphere.
5. Owner will be responsible for return of faulty components to QHT Inc. Portsmouth, NH, freight pre-paid.

QHT and Biasi will not be responsible for:

1. Components that are part of the heating system, but were not manufactured by Biasi or QHT as part of the boiler.
2. The workmanship of the installers of 3WOOD boilers. Furthermore, this warranty does not assume any liability for unsatisfactory performance caused by improper installation.
3. Any costs for labor to remove or replace the faulty component.
4. Improper burner application or adjustments, control settings, care or maintenance.
5. Any damage associated with corrosion or leakage due to the use of "non-barrier", plastic pipe in the heating system.

***THIS WARRANTY DOES NOT EXTEND TO ANYONE EXCEPT THE FIRST PURCHASER AT RETAIL AND ONLY WHEN THE BOILER IS IN THE ORIGINAL INSTALLATION SITE.**

***IMPLIED WARRANTIES OF FITNESS FOR A PARTICULAR PURPOSE AND MERCHANTABILITY SHALL BE LIMITED TO THE DURATION OF THE EXPRESSED WARRANTY. BIASI AND QHT EXPRESSLY DISCLAIM AND EXCLUDE ANY LIABILITY FOR CONSEQUENTIAL OR INCIDENTAL DAMAGES FOR BREACH OF ANY EXPRESSED OR IMPLIED WARRANTY.**

THIS WARRANTY GIVES YOU SPECIFIC LEGAL RIGHTS, AND YOU MAY HAVE OTHER RIGHTS THAT VARY FROM STATE TO STATE.

For prompt warranty service, notify the installer, who, in turn, will notify the distributor from whom he purchased the boiler. If this does not result in corrective action, contact Biasi through Quincy Hydronic Technologies (Address Below) with details in support of the warranty claim. All claims must be processed through proper trade channels. Contact with Biasi directly is not recommended for rapid claim settlement.

Quincy Hydronic Technologies,
3560 Lafayette Rd.
Portsmouth, NH, 03801
Tel. (603) 334-6400

TEAR ON THIS LINE

BIASI BOILER WARRANTY REGISTRATION

IMPORTANT., Registration required. To gain complete warranty protection, fill in and mail this card immediately.

NAME _____

STREET _____

CITY _____ STATE ____ ZIP _____

BOILER SERIAL NO. _____ DATE OF INSTALL _____

NAME OF INSTALL CO. _____

STREET _____

CITY _____ STATE ____ ZIP _____

B10 BOILER SIZE (EX. 4 SECTION) _____

SILVER RATINGS LABEL SERIAL # _____

HOW DID YOU HEAR ABOUT BIASI?

- DEALER/INSTALLER WEBSITE FRIEND/NEIGHBOR
 OTHER

**PLACE
STAMP
HERE**

QHT Inc.
3560 Lafayette Rd
Portsmouth, NH 03801

QHT **BIASI**

The New Style of Warmth

For service please contact:

QHT Inc.
3560 Lafayette RD
Portsmouth, NH 03801

Email: info@qhtinc.com
Web: www.qhtinc.com
Telephone: 800-501-7697
Fax: 603-334-6401

3 WOOD Boiler
Manufactured by:
Biasi S.p.A
Verona, Italy