

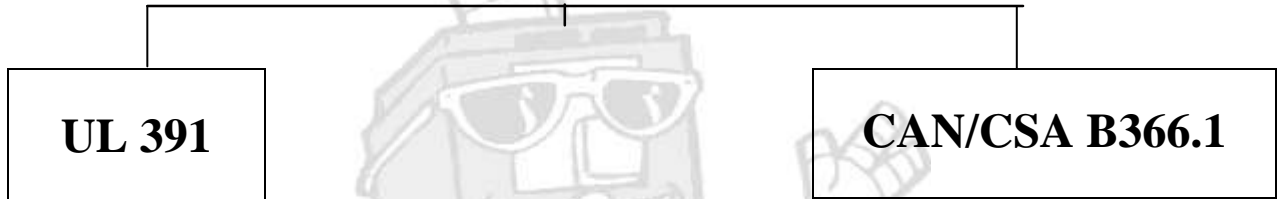

*OWNERS MANUAL*  
MODEL  
**WK400/WK400A**

IS CERTIFIED TO:



Unit Serial # \_\_\_\_\_

Purchased From \_\_\_\_\_

Company Address \_\_\_\_\_

\_\_\_\_\_

Name of Installer \_\_\_\_\_

Installer Telephone # \_\_\_\_\_

Date Installed \_\_\_\_\_



**IMPORTANT**

This manual must be given to the homeowner. Please read the warranty and return the warranty card to initiate coverage.

**We Strongly Recommend The Use Of A Carbon Monoxide Detector When Using Any Product That Consumes Fossil Fuels.**

It is the responsibility of the person or company installing this furnace to **verify before the installation** that the furnace certifications shown on this page meet or exceed all local, state and regulatory requirements for installation and use of this furnace. Failure to do so voids all claims and warranties.

**March 2010**

**Aussi disponible en Français**

***Follow all instructions carefully for the installation, maintenance & operation of the "WK400 Furnace" or the "WK400A ADD-ON". KEEP THIS MANUAL FOR FUTURE REFERENCE.***

**NOTE:** The consignee is responsible for ensuring that the packages arrive in good condition. Examine the packages for damages. If found, note the same on the carriers' bill of lading and make a claim on the carrier.

The "WK400" wood furnace is in two packages.

**Package No. 1** The furnace (heat exchanger, firebox, casings), 1-cleaning hoe, 1-damper motor and chain, 1-24 volt transformer, J-box and cover, 1- fan limit control c/w bracket and 1-thermostat.

**Package No. 2** 1-blower, 1-blower motor, blower casings, 1-belt, 2-pulleys, 1-filter.

The "WK400A" Add-on wood furnace is in one package.

**Package No. 1** The furnace (heat exchanger, firebox, and casings), 1-cleaning hoe, 1-damper motor and chain, 1-24 volt transformer, J-box and cover, 2- fan limit controls c/w brackets and 1-thermostat.

## INSTALLATION

This installation must comply with the applicable requirements of (**Canada**) CSA Standard B365, Installation Code for Solid fuel burning Appliances and Equipment, (**United States**) UL 391, Solid Fuel and Combination-Fuel Central and Supplementary Furnaces and if any changes are made to the installation of the oil furnace, these must comply with (**Canada**) CSA Standard B139, Installation Code for Oil Burning Equipment, (**United States**) UL 727, Oil-Fired Central Furnaces. Electrical and mechanical installations must conform to all local and national codes and standards as their jurisdiction may apply.

## CHIMNEY AND SMOKE PIPE

The specification of the chimney to be used, must comply with the requirement that, other than solid-fuel/oil combinations and add-ons, wood burning appliances shall not be connected to a venting system serving an appliance vented by another type of fuel. Connect the furnace to an approved solid fuel factory-built chimney: **in CANADA**-CAN/ULC S629 standard for 650° chimney, **in the UNITED STATES**-UL103 Chimneys for Residential Type and Building Heating Appliances, Factory Built or a safe, clean, sound condition, masonry chimney equipped with an approved liner: **in CANADA**-CAN/ULC-S635-M90 Standard for Lining Systems for existing masonry or Factory Built Chimneys and Vents, **in the UNITED STATES**-UL1777 Chimney Liners (e.g., stainless steel, clay, etc.). The chimney must be equivalent to a minimum of 7" round inside diameter or 8" round maximum. The chimney must be capable of maintaining a negative updraft at all times and in all conditions. Carefully inspect the chimney for safety and dirt before making connections. Place the furnace as close to the chimney as possible.

The smoke pipe should be blue or black steel, 24 ga. or heavier. Use as few turns as possible between the furnace and the chimney, as each 90° elbow adds 10' of restriction and a 45° elbow adds 5' of restriction. The barometric damper should be 7" diameter and set at -.04 W.C. to open. Install the barometric damper a minimum of 18" and a maximum of 24" from the furnace breech. Avoid long horizontal runs of smoke pipe. Maintain a minimum of ½" rise per foot of pipe from the furnace to the chimney.

**DO NOT** run the pipe downhill from the furnace to the chimney. Confirm that the installation clearances are met or exceeded. All pipe joints should fit relatively gas tight. Secure all smoke pipe joints with three sheet metal screws in each joint.

**DO NOT** pass the smoke pipes through a wall, floor or ceiling to reach the chimney.

Remove the smoke pipe from the furnace and clean monthly or as necessary.

**NOTE:**

Maximum fan limit setting 240 degrees F. **DO NOT** set flue draft above 0.05" W.C. If the furnace is installed in a tight (air sealed) basement or furnace room, adequate air must be supplied for combustion and ventilation, or the furnace will NOT work properly.

**Use only metal ducts for this furnace.**

### COMBUSTION AIR

To achieve satisfactory combustion, an adequate supply of fresh air is required. In confined areas, a grilled opening should be provided. The minimum total area of opening is 1 square foot per 100,000 BTU/HR (total the combined maximum BTU's of the two furnaces), for a WK400A ADD-ON. Where fans are used in the fuel storage area, they should be installed so as not to create negative pressures in the room where the furnace is installed.

### FIREBOX

The firebox must be filled and maintained with sand or ash to 1-1/2" below fire door sill. This is to ensure proper air flow thru the fire.

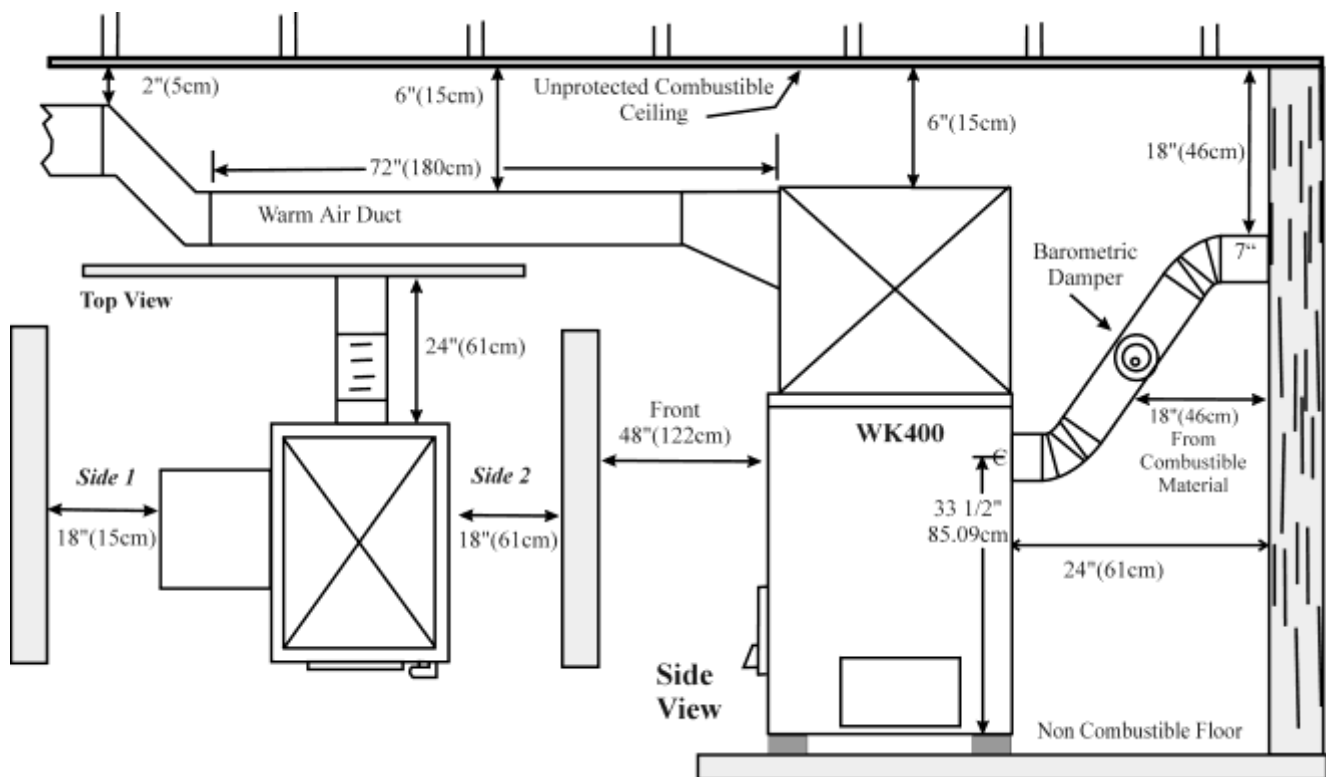

### MINIMUM CLEARANCES

The furnace must be installed on a non-combustible floor.  
Minimum clearances from combustible material are as follows:

- Front: 48"
  - Sides: 18"
  - Rear: 24"
  - Smoke Pipe: 18"
  - Top of Plenum and first 6' of duct: 6", then 2"
- CLEARANCES MUST BE MAINTAINED**

## INSTALLATION INSTRUCTIONS FOR THE WK400A

The BENJAMIN WK400A wood furnace is certified by the Canadian Standards Association for series connection to the outlet only of an existing electric, gas or oil fired furnace. The instructions for the care and operation of the WK400 forced air furnace which appear elsewhere in this manual, also apply when used as an add-on. In addition, the following instructions must be observed to ensure your safety and comfort. Ensure that there is a minimum of 200 sq. inches of return air back to the furnace.

1. The WK400A may be connected to warm air furnaces with an air volume of 1100 to 1300 CFM, a warm air furnace having an oil input as shown on the original name plate between **.85 GPH (US)** minimum and **1.10 GPH (US)** Maximum or an existing warm air furnace having an output of 100,000 to 130,000 BTU's per hour. Units outside of these ratings are not suitable for connection to the WK400A.
2. The interconnecting duct shall have a crossed sectional area of not less than 240 sq. in., and the duct elbows shall have a minimum inside radius of six inches.
3. The installer will find it necessary to cut the proper size holes in the appropriate side panel of the furnace (See **Diagram** on page 8).
4. A typical add-on installation is shown on page 8. This configuration must be followed.
5. The wiring must be installed by a qualified licensed electrician. Wire the add-on wood furnace in accordance with page 9, using the controls provided. The proper positioning of the controls on the wood unit is shown on page 8. The interconnecting wiring from the primary furnace to the wood furnace shall conform to all local codes and regulations. It is recommended that an approved metal conduit be used for this purpose.

### **CAUTION:**

**DO NOT** connect the duct work in such a manner that reverse air flow is possible.

**DO** Operate the primary furnace periodically to ensure that it will operate satisfactorily when needed.

**DO NOT** relocate any of the safety controls in the original installation.

**DO** Be sure that the duct system is in good condition and that the chimney is suitable for connection to a wood burning appliance.

**DO NOT** change the primary furnace blower. (Pulleys and motor may be changed.)

A central location is most desirable for a hot air furnace. A short distance from the chimney with large ducts will give best results.

**DO NOT** connect this unit to an automatic stoker.

## INSTALLATION

Electric and mechanical installation must conform to all local and national codes and standards as their jurisdiction may apply. It is imperative that a qualified installer be engaged who is familiar with local codes and standard requirements. Select a standard position for your furnace, close to the chimney using large ducts. Connect only to a flue approved for solid fuels. Install the thermostat in a location free from drafts. Place the furnace on a non-combustible floor. The blower compartment may be placed on either the right or left side. (Blower compartment instructions are included.)

**ELECTRICAL** See Page 9 & 11

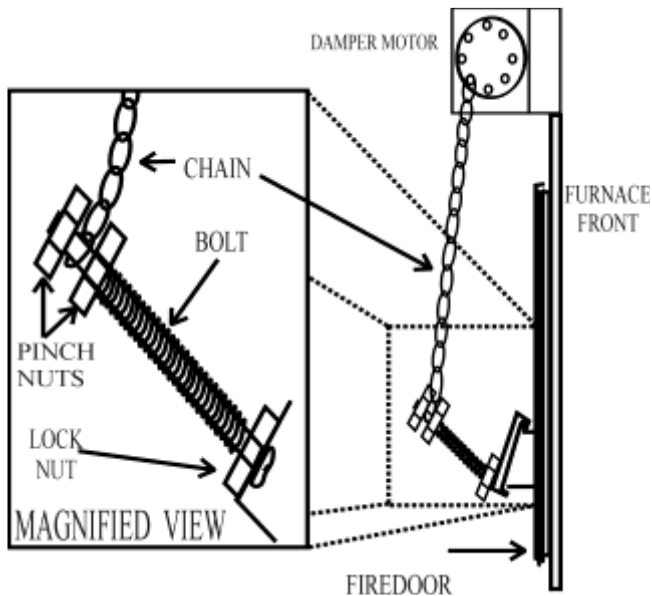

## ADJUSTMENTS OF DAMPER MOTOR AND CHAIN:

The damper chain should be adjusted when the damper door is in the down position. In this position the chain should be adjusted so there is a small amount of slack. The amount of lift or opening of the damper door is adjusted by moving the two pinch nuts on the stove bolt thread closer or further away from the lift strap. After proper adjustment of the draft chain and damper door the thermostat and limit controls will keep the fire within safe limits.

**NOTE:** The combustion damper shall **NOT** be permitted to open more than 1" at the bottom.

**Caution:** The damper opening should not be altered for increased firing for any reason.

## TO THE INSTALLER

It is necessary to ensure that there is sufficient air flow through each furnace after the add-on installation has been completed. It is suggested that the temperature rise method be used since most installers are likely to have the necessary equipment. The temperature measurements may be made using a potentiometer and thermocouples, mercury thermometers. If thermometers are used, sufficient time must be allowed for the thermometer to reach actual temperature. As much as twenty minutes may be required.

## PROCEDURE

To check the existing system, drill a hole 1/4" in the side of the return air plenum on the primary furnace and a similar 1/4" hole in the side of the main supply air duct, 24" from the supply air plenum. Insert a temperature measuring device in each of these holes and start the primary furnace. Allow the furnace to operate until all temperatures have stabilized. This will take at least 1/2 hour. Read the two temperatures thus obtained and not the difference, TS--TR (see page 8). This difference should not exceed 85 degrees F. (29° C.)

Complete the installation of the WK400A in the add-on mode, in accordance with page 8, and drill a third 1/4" hole in the 20" x 12" duct (See TA, page 8). Insert a temperature measuring device.

Operate the primary furnace until the temperature rise TA-TR across the primary furnace is equal to or less than 85 degrees F. (29° C). Should this temperature difference exceed 85 degrees F (29° C), increase the blower speed by pulley adjustment and/or change until the temperature rise TA-TR is equal to or less than 85° F. (29° C.)

Shut off the primary furnace and build a fire in the wood unit. When the fire is established, fill the fire box to the bottom of the smoke shield, in the fire door opening (maximum level). Open the combustion air damper. Allow the temperature to stabilize and measure the temperature difference TS- TR. should it exceed 85° F. (29° C), a further increase in blower speed will be necessary.

Once the proper air temperature rise has been obtained, an ammeter should be connected to the blower motor to measure current draw. If it exceeds the name plate rating, change the motor to a higher rating (if the old motor was a two stage, ensure that the new motor is as well). It is permissible to change the blower motor and blower drive pulleys in the primary furnace but NOT the blower unit.

This equipment must be installed according to the manufacturer's instructions and in a manner acceptable to the regulatory authority having jurisdiction by mechanics experienced in such a service. When required regulatory authority, such mechanics shall be licensed to perform this service.

## BLOWER MOTOR

The variable speed pulley must be set to give, not greater than, 85 degree F. temperature rise with a plus .20" W.C. static pressure. Setting is necessary due to the varying resistance found in duct systems.

### BLOWER COMPARTMENT ASSEMBLY

1. Screw the blower frame on the chosen side panel 1" from bottom of the furnace base and in the center of the side panel.
2. Scribe a line around inside of the blower frame, remove the blower frame and cut out the blower opening in the side panel.
3. Cut and fit the foil faced insulation inside blower frame (see section A-A). Install the frame on the side panel.
4. Remove the blower and filter from the compartment. Install 2 - 3/16" stove bolts through the bases. Install 8 sheet metal screws as shown. Ensure the blower casing is square so the door fits properly.
5. Ensure the furnace and blower are well supported on a noncombustible floor.
6. Reinstall the blower and filter. Blower mouth should extend 1/2" inside the furnace side panel.
7. Check the blower pulleys for alignment and
8. Install electrical components as shown and wire as per diagram.
9. Mount the fan limit as shown, using the bracket provided.
10. If properly mounted, the blower will make contact with foil faced insulation 1/8" all around.
11. Use insulation obtained from cutout for blower gasket.

**Do NOT** use a manual smoke damper with this unit.  
This furnace must be installed by a qualified installer.

Use only metal ducts for this furnace.

**Do NOT** allow inexperienced persons to service fire.

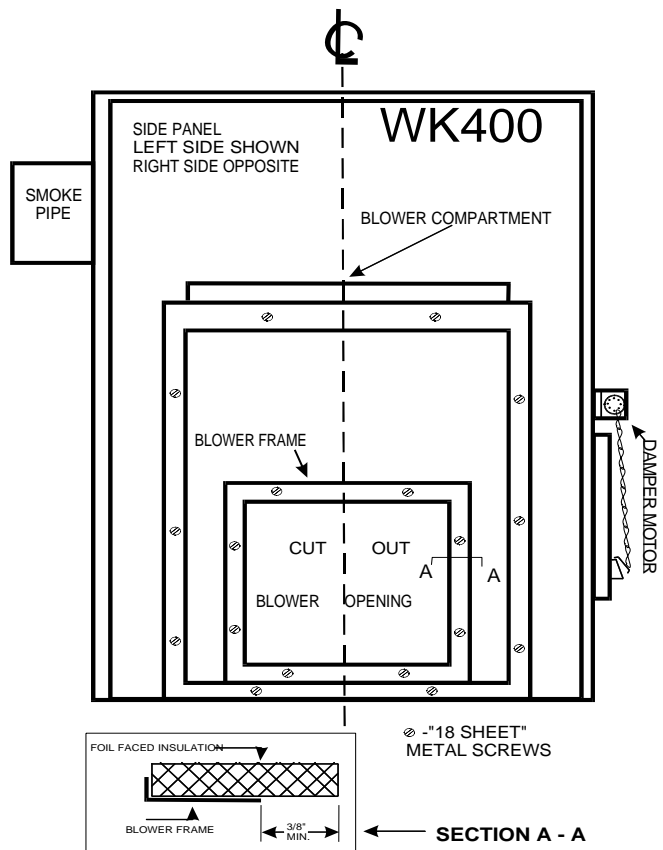

### INSTRUCTIONS FOR OUT OF CONTROL FIRE

(Caused by excessive fueling and/or soot or creosote build up or too much draft)

1. Close the supply of combustion air by lowering the thermostat to a minimum setting and unhook the damper motor chain.
2. Block the over-fire draft slot in the door.
3. Reduce the draft by fully opening the barometric damper.
4. As excess heat may damage safety controls, they should be carefully checked before restarting the furnace.

**CAUTION:** Too much air can cause the fire to burn out of control. Adjust screw or chain to maintain small fire. A damper motor will safely control larger fires. Keep the fire door closed as much as possible. The door gaskets and clean out cover seals must be maintained in good condition to maintain safe operation.

## **POWER FAILURE OPERATION**

**NOTE: DO NOT** operate your appliance, unless your total heating system has been designed and installed to operate properly without electricity.

1. Remove the blower door and filter.
2. Using a non-combustible material, brace the draft door open (1/4" maximum).
3. Open all warm air registers and dampers.
4. Open the furnace room door & the basement door, to permit gravity air flow circulation.
5. Maintain the fire at 1/2 normal levels.
6. Inspect the fire at frequent intervals to ensure safe operation.

## **FLUE FIRE**

1. Call the Fire Department.
2. Prepare to evacuate the house.
3. Shut off the main power switch to the furnace.
4. Diminish the fire in the furnace by closing all combustion air openings.
5. **DO NOT** remove the flue pipes until the fire is completely out.
6. Have the chimney inspected and repair the flue before using it again.

**DO NOT STORE FLAMMABLE MATERIALS OR LEAVE PAPER OR RAGS IN THE VICINITY OF THE FURNACE**

Burn **WOOD** only. **USE PAPER TO START A FIRE ONLY.**

Remove ash at regular intervals to prevent residue roll out from the fire door.

**DO NOT** fill the firebox above the smoke baffle at top of fire door frames.

**DO NOT** use fluids, gasoline, oils or chemicals to start a fire.

**DO NOT BURN GARBAGE**, tar products, gasoline, plastics, drift wood or materials containing salt or chemicals. This is extremely dangerous and will void the warranty. Burn wood only. Fuel storage must conform to local ordinances having jurisdiction.

## **CLEANING AND MAINTAINING YOUR "WK400"**

Establish a routine for the storage of fuel, care of the appliance and firing techniques.

Check daily for creosote build up until experience shows how often cleaning is necessary.

Be aware that the hotter the fire, the less creosote is deposited. Weekly cleaning may be necessary in mild weather even though monthly cleaning may be enough in the coldest months. Have a clearly understood plan to handle a chimney fire. Ensure that the heat exchanger, flue pipe and chimney are cleaned at the end of the heating season to minimize corrosion in the summer months.

### **NOTE:**

Keep the furnace, vent pipe and chimney clean. This will increase efficiency and reduce the risk of soot and creosote fires.

Solid fuel requires a sufficient supply of air for combustion and combustion air is required above the fuel bed (over fire slot at the top of the door).

Clean and inspect as necessary (at least yearly).

## **ASHES**

Ash should be removed before it reaches the bottom of the fire door frame. Sand or ash should be 1 1/2" below the bottom of the fire door frame. This will ensure proper air flow thru the fire. Ashes when removed from the furnace should be placed in a metal container with a tight fitting lid and immediately removed to a safe location. Ashes often contain hot dormant coals.

## TO CLEAN HEAT EXCHANGER

1. Remove clean out casing. (top front panel above firebox.)
2. Remove the two round clean out covers by removing the nuts from the heat exchanger.
3. Remove the rectangular cover from the combustion tunnel by removing the two nuts. This cover is located below and between the round covers, on the top front of the firebox.
4. Clean with a wire brush. It may also be necessary to remove the smoke pipe to clean the rear of the heat exchanger.
5. Make sure the gaskets are in good condition (replace if necessary).
6. Replace the covers in reverse order.

## BLOWER and MOTOR

Twice yearly, oil the blower & motor bearings with 4 drops of #20 SAE oil. Twice yearly, oil the blower motor bearings with 2 drops of #20 SAE oil. DO NOT over oil.

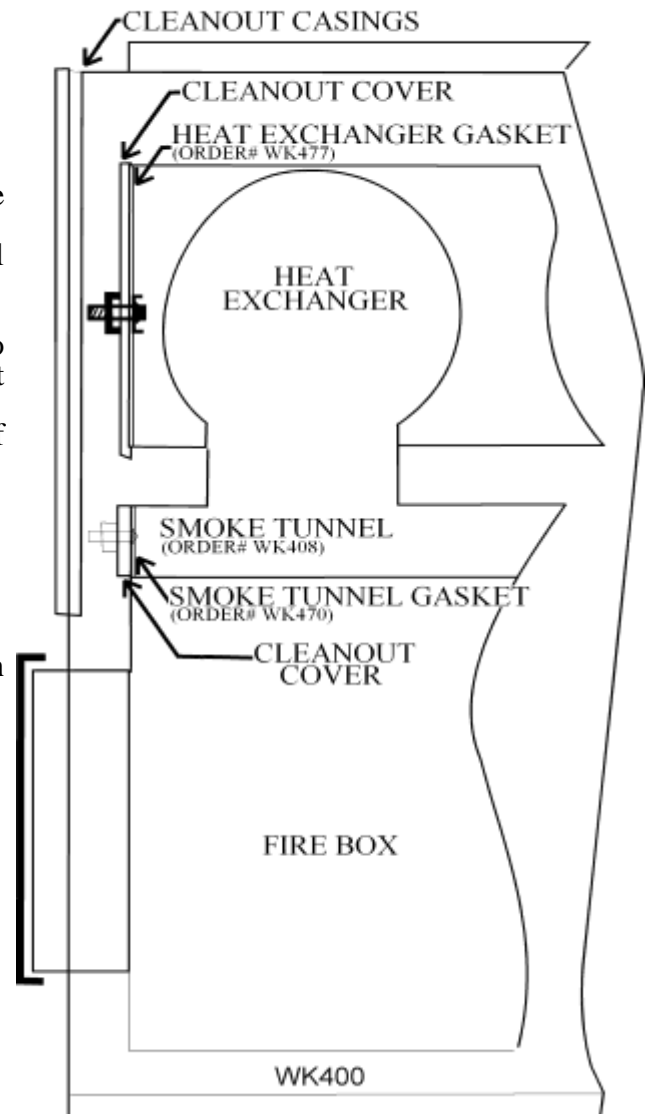

## AIR FILTER

The filter should be inspected at least monthly and replaced (16" x 20" x 1") as necessary. To replace filter, turn off power to unit, remove blower access door, remove old filter and replace with new, replace blower access door and restore power.

### IMPORTANT NOTES:

- Know the location of the emergency disconnect switch for the furnace.
- If remodeling in the area of the furnace call a service technician.
- Do not tamper with the furnace or controls - CALL YOUR SERVICE TECHNICIAN.



# TYPICAL "ADD-ON" INSTALLATION

## WK400 Add-On

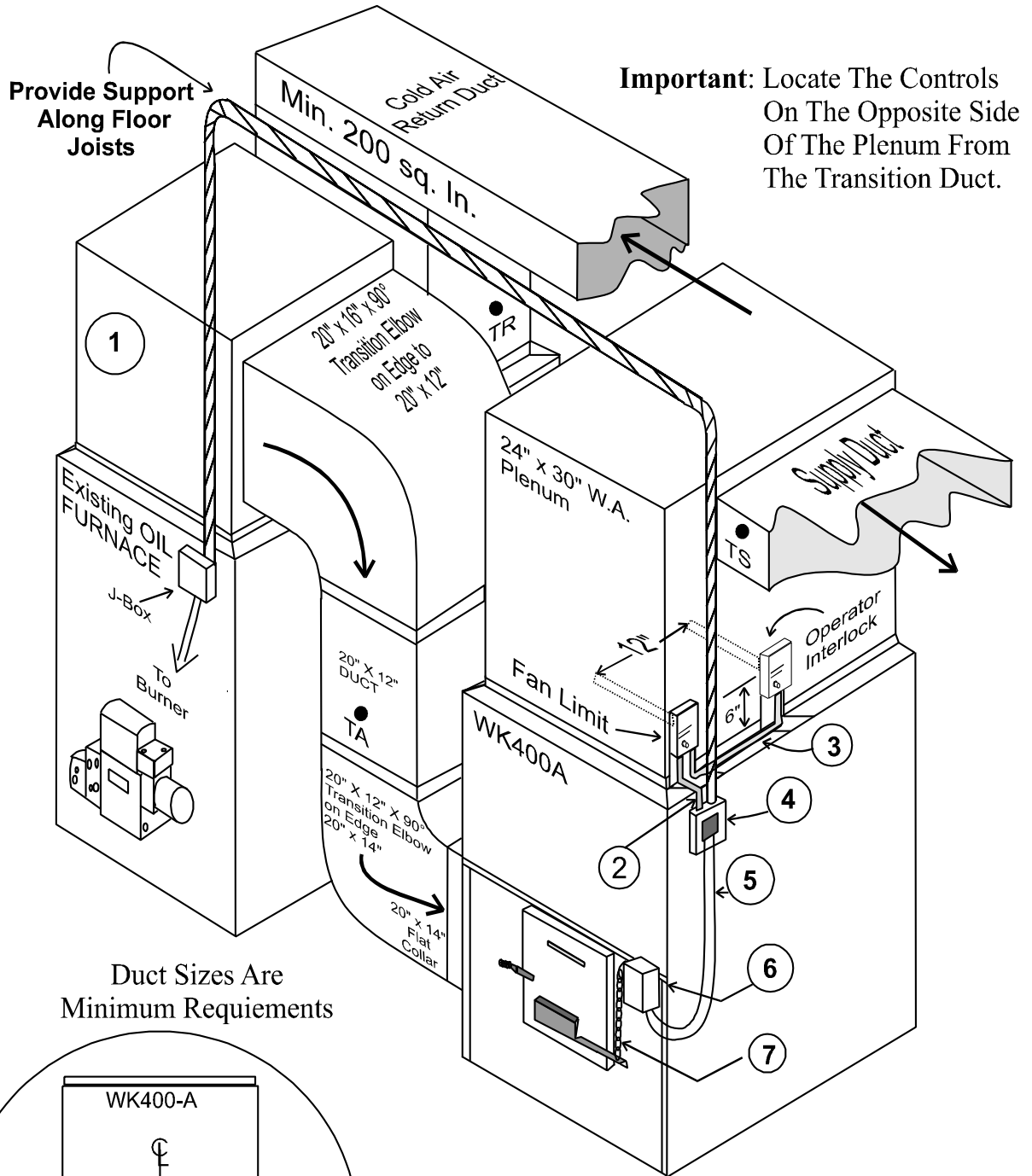

Duct Sizes Are Minimum Requirements

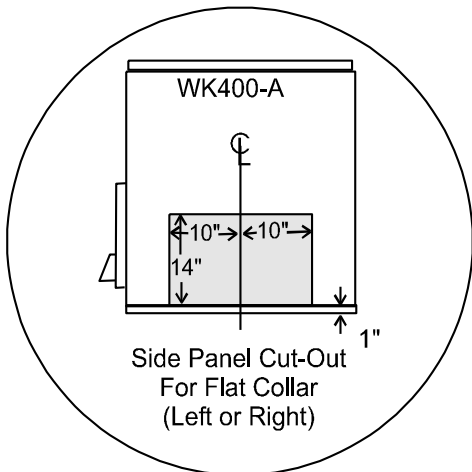

1. Oil Furnace Plenum
2. TEW-90 # 16-3
3. TEW -90# 16-2
4. J-Box and Transformer
5. 24 Volt Wire
6. Damper Motor
7. Damper Chain

# WK400 ADD-ON (Connected to an Existing Oil Furnace)

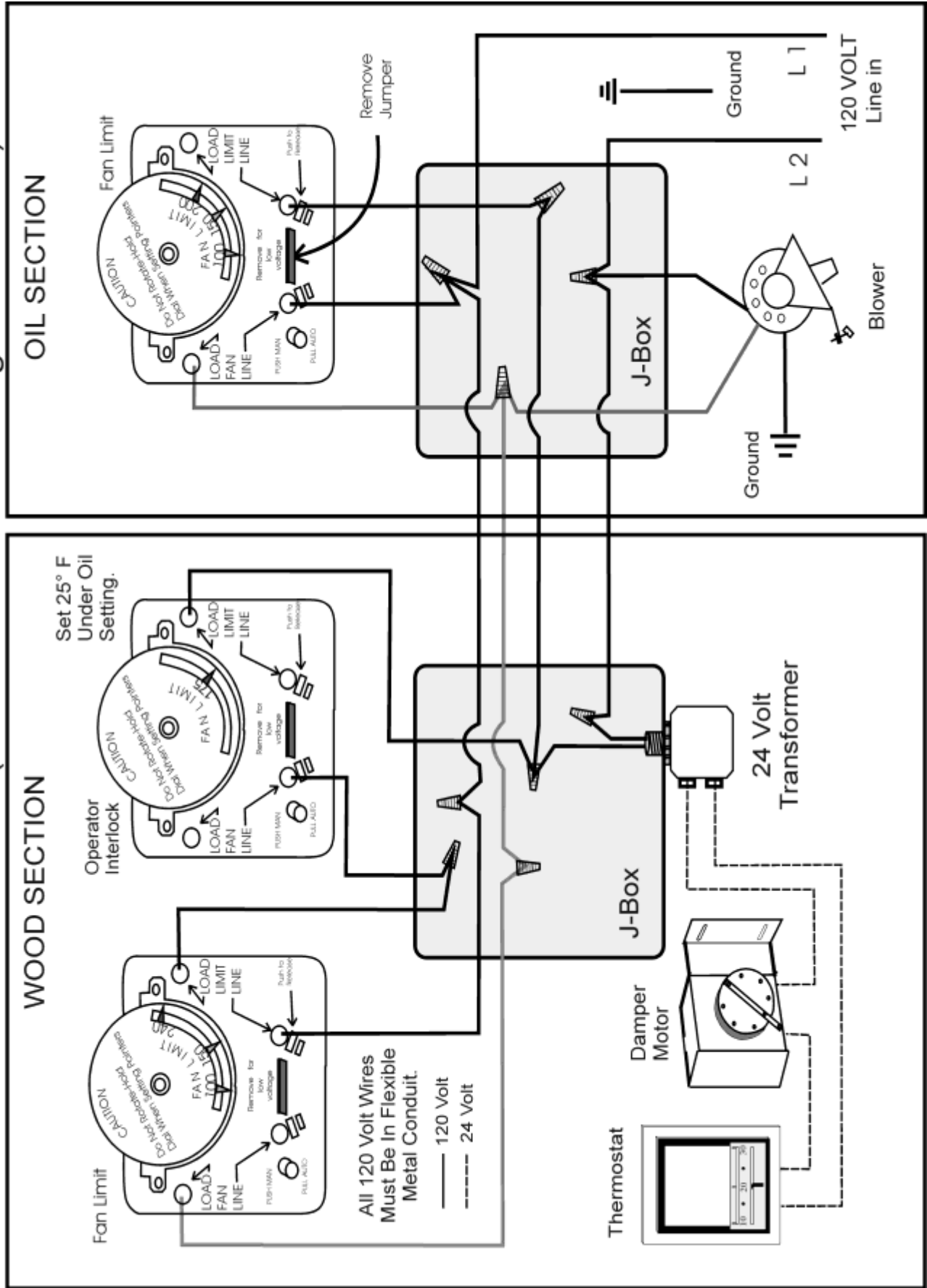

# RECOMMENDED WIRE ROUTING WHEN USED AS A FREE STANDING UNIT

## WK400 Furnace (Stand Alone)

1. Blower Box Plenum 16" X 22"
2. Blower Box
3. TEW-90 #16-2 Wire
4. W/A Plenum 24"X 30"
5. Fan Limit Control
6. TEW-90 #16-3 Wire
7. Transformer & J-Box
8. Damper Motor
9. 24 Volt Wire
10. Damper Chain

**Note:** The Controls Are Located On The Opposite Side From The Blower.

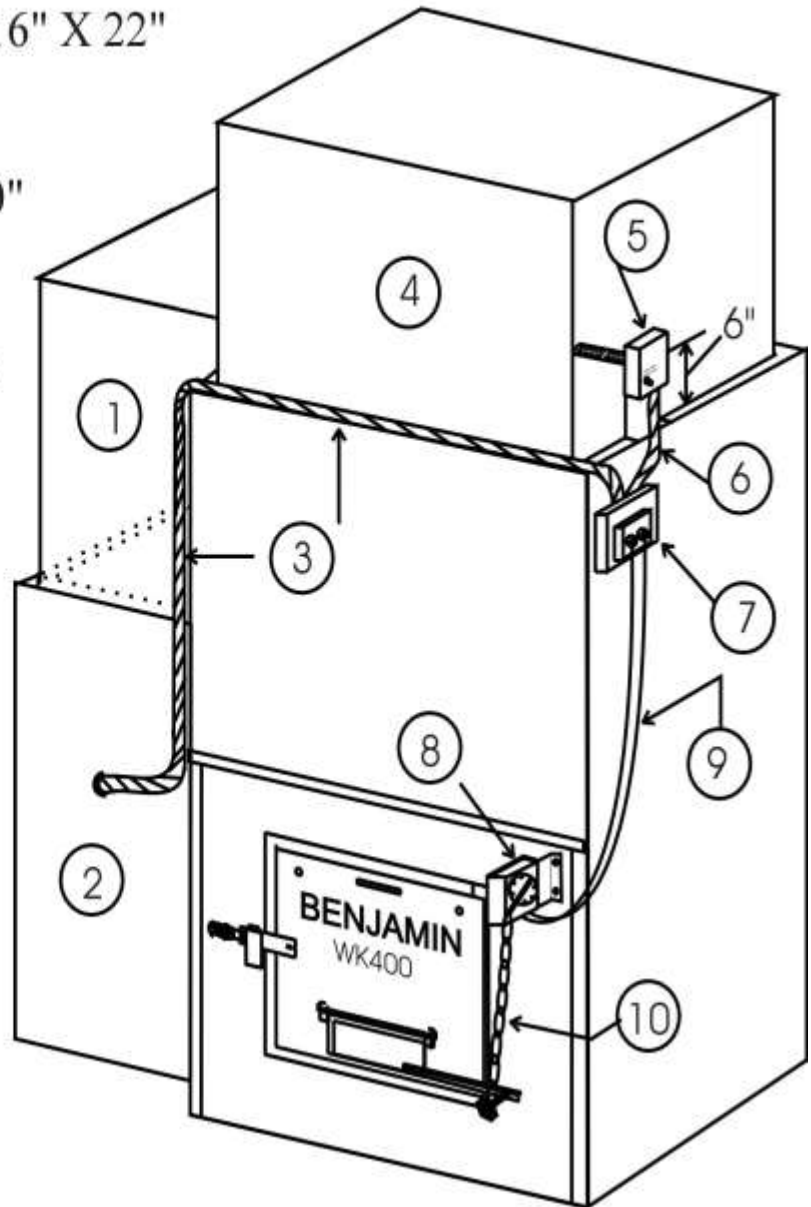

**NOTE: THE BLOWER BOX CAN BE MOUNTED ON EITHER SIDE.**

# WK400 WOOD FURNACE (stand alone)

## Wiring Diagram

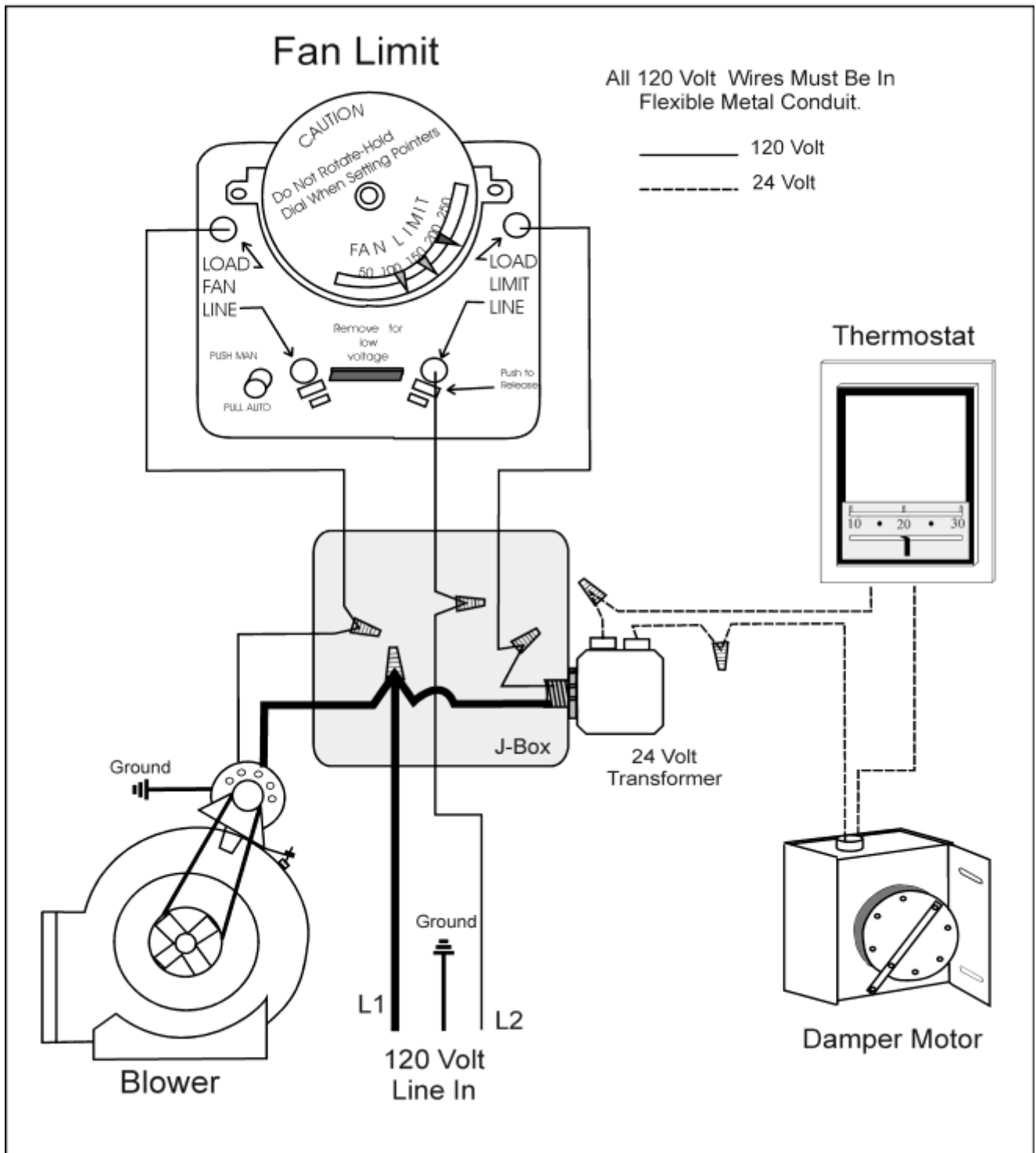

# Wood Furnace Operating Cycle

## START UP

The thermostat calls for heat...

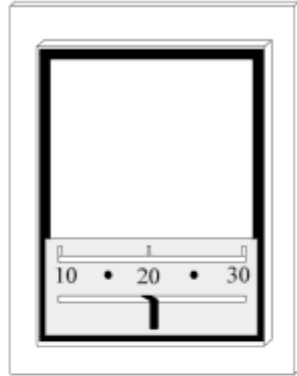

Activates the damper motor, allowing air into the firebox.....

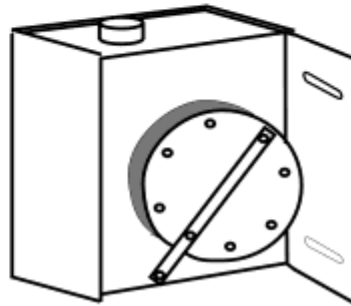

Resulting in a hotter fire.



The fan control senses heat in the supply plenum...

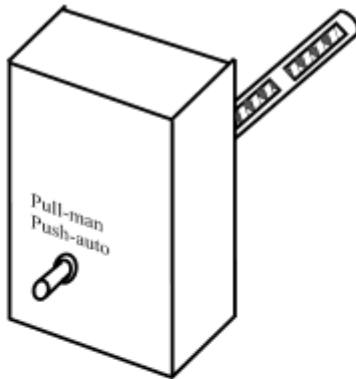

And activates the blower motor, forcing warm air through the supply ducts.

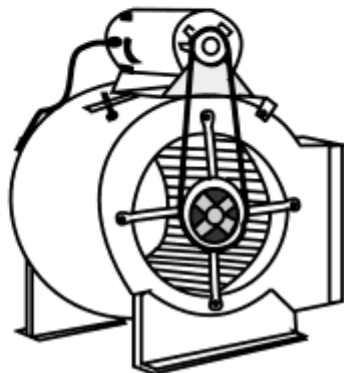

## COOL DOWN

The thermostat senses the desired heat level and signals...



The damper motor to close the combustion air damper,

Resulting in a low fire.



The fan control senses low temperature in the supply plenum...



And shuts off the blower motor.

**Notes:**

**Notes:**



**A division of W.R. BENJAMIN PRODUCTS LIMITED**  
**P.O. Box 2079, Springhill, Nova Scotia**  
**Canada B0M 1X0**  
**Phone: (902) 597-3796**  
**Fax: (902) 597-3797**  
**E-mail: [info@benjaminheating.com](mailto:info@benjaminheating.com)**  
**Web site: [www.benjaminheating.com](http://www.benjaminheating.com)**