



PSG
1700, Léon-Harmel
Québec(Québec)
G1N 4R9

INSTALLATION AND OPERATION INSTRUCTIONS FOR WOOD/OIL BURNING COMBINED FURNACES PSG/UH 2000-3000-4000-4500 AND UH-CADDY

**READ THIS MANUAL THOROUGHLY
BEFORE OPERATING THE FURNACE**

CERTIFIED WARNOCK HERSEY BY INTERTEK TESTING SERVICES LTD
ACCORDING TO CAN/CSA B366.1-M91, UL391 3e ed. 1995, rev. 1999 & CAN/CSA
B212-93 (JUNE 2000)

CAUTION

CAUTION

EXPLOSION OR FIRE HAZARD.
FOR YOUR SAFETY: DO NOT
STORE OR USE GASOLINE OR
ANY FLAMMABLE LIQUIDS OR
VAPORS IN THE VICINITY OF
THIS HEATING UNIT.

DO NOT ATTEMPT TO LIGHT THE
BURNER WHEN EXCESS OIL HAS
ACCUMULATED, WHEN THE
APPLIANCE IS FULL OF VAPOR OR
WHEN THE COMBUSTION
CHAMBER IS VERY HOT.

DO NOT BURN WASTES OR PAPER IN THE APPLIANCE.
DO NOT LEAVE PAPER OR ANY COMBUSTIBLE MATERIAL
AROUND THE APPLIANCE.

Aug 2005

PLEASE SAVE THESE DOCUMENTS!

Table of contents

GENERAL NOTES 3

1. DRAFT AND CHIMNEY 3

2. OIL TANK AND PIPING 4
BURNER PUMP 4

3. APPLIANCE INSTALLATION 4
A- LOCATING THE UNIT..... 4
B. CLEARANCES TO COMBUSTIBLE MATERIALS 5
C- POSITIONING THE APPLIANCE 7
D- PIPE CONNECTOR AND DAMPER..... 7
E- COMBUSTION AIR..... 10
F- ELECTRIC COMPONENTS INSTALLATION 11
G- ELECTRICAL WIRING 12
H- THERMOSTAT 12
I- FAN CONTROL..... 12
J- COMBUSTION SAFETY CONTROL 13
K- COMBUSTION ADJUSTMENT AND VERIFICATION 14
L- ELECTRODES SETTING 15

4- APPLIANCE START-UP 15

5- PROLONGED CLOSING 15

7- ELECTRICAL DIAGRAMS..... 18

8- TECHNICAL DATA 20

LIMITED LIFETIME WARRANTY 21

GENERAL NOTES

This instruction manual treats mainly of the oil burning unit of your wood/oil combination furnace.

For any additional information concerning the wood burning furnace, please consult your installation and operation instructions manual for wood and wood/electricity furnaces.

To obtain the optimal efficiency, follow the advices below regarding the installation and operation of your WOOD/OIL combination furnace.

Respect the local codes (when in doubt, consult your local heating appliances dealer).

Make sure that the clearances indicated on the certification plate correspond to the specifications in the instruction manual.

Make sure that your furnace is installed in conformity with the instructions on the name plate.

All the controls adjustments must be performed by a qualified technician. The controls settings and the fan speed must be in compliance with the recommendations of the Warm Air Heating and Air Conditioning National Association and must respect the static pressure ranges in the warm air plenum of the furnace.

THE INSTALLATION OF THE WOOD/OIL COMBINATION FURNACE MUST BE DONE IN ACCORDANCE WITH THE RULES OF THE AUTHORITIES HAVING JURISDICTION AND THE CAN/CSA B-139 M-91 STANDARD FOR OIL BURNING HEATING APPLIANCES.

The oil burning furnaces are not approved for use with combustible heavier than No.2 oil (furnace oil). **DO NOT USE GASOLINE, TRANSMISSION OIL OR OTHER TYPE OF OIL CONTAINING GASOLINE.**

1. DRAFT AND CHIMNEY

The chimney must conform to the rules of the authorities having jurisdiction and the CAN/CSA B139 M-91 & NFPA 31 standard regarding installation of oil burning heating appliances. The installation of the connecting pipes to the oil unit must be done and approved by a qualified pipe fitter.

The barometric damper provided with the appliance must be properly installed on the flue pipe of the oil unit. The purpose of the damper is to limit the draft, if necessary, in the oil unit evacuation pipe.

Since the evacuation pipe of the oil unit is connected to the evacuation pipe of the wood burning furnace, **the minimum draft to be respected at all times in the evacuation pipe of the wood burning side is - 0.04" W.C.**

2. OIL TANK AND PIPING

The maximum capacity of the tank must be 200 gallons and the tank must be located at least 7 feet from the burner. Local codes will govern the size of the air inlets and filling openings as well as the type of plugs to be used. 1 1/4" IPS and 2" IPS are usually accepted as minimum dimensions for the air intake pipes and fill pipes, respectively. The oil line to the burner must be a 3/8" outside diameter copper tubing for runs up to 50 feet and 1/2" o.d. for longer runs. A manual shut-off valve and an oil filter shall follow in sequence on the oil line between the oil tank and the burner. The oil line must be buried or protected adequately to avoid any damage.

BURNER PUMP

The burner is equipped with a single stage pump. When the pump is connected to a single feeder pipe, a maximum rise of 8 feet is allowed. This height is measured from the tank outlet level to the burner inlet.

When the rise is more than 8 feet and not exceeding 10 feet, a by-pass plug (provided with the burner) must be inserted in the pump and an oil return pipe must be installed. ***For more details, see "INSTALLATION INFORMATION", Part No. 21844 on the burner pump.***

If the rise is higher than 10 feet, a two stage pump may be required along with an oil return pipe.

3. APPLIANCE INSTALLATION

A- LOCATING THE UNIT

The furnace must be installed in a location where combustion air is available in sufficient quantity. In airtight houses, the installation of an outside air intake might be required. (See details in 3- APPLIANCE INSTALLATION, E- COMBUSTION AIR).

The owner is responsible for ensuring a proper installation to allow a salubrious operation of the appliance.

Position the furnace so that the connecting pipe is as short as possible and limit the use of 90° elbows to a minimum.

Provide sufficient clearance to permit easy access for maintenance of the filters, motors, controls and pipe connectors.

B. CLEARANCES TO COMBUSTIBLE MATERIALS

MINIMUM INSTALLATION CLEARANCES TO COMBUSTIBLE MATERIALS	
WARM AIR PLENUM AND FIRST 6 FEET OF DUCT	6 in. (152 mm)
PLENUM AFTER THE FIRST 6 FEET = B	2 in. (51 mm) ALL MODELS EXCEPT CADDY = 1 in. (25.4 mm)
REAR (INCLUDING CLEARANCE FOR MAINTENANCE) = A	29 in. (737 mm) ALL MODELS EXCEPT CADDY = 24 in. (610 mm)
SIDES (INCLUDING CLEARANCE FOR MAINTENANCE)	24 in. (610 mm)
OIL BURNING UNIT FLUE PIPE	9 in. (229 mm)
WOOD BURNING FURNACE FLUE PIPE	18 in. (458 mm)
* FLOOR	0 in. (0 mm)

*** ALL OUR FURNACES MAY BE INSTALLED ON A COMBUSTIBLE FLOOR.**

N.B. These appliances must be installed in conformity with the instructions on the name plate.

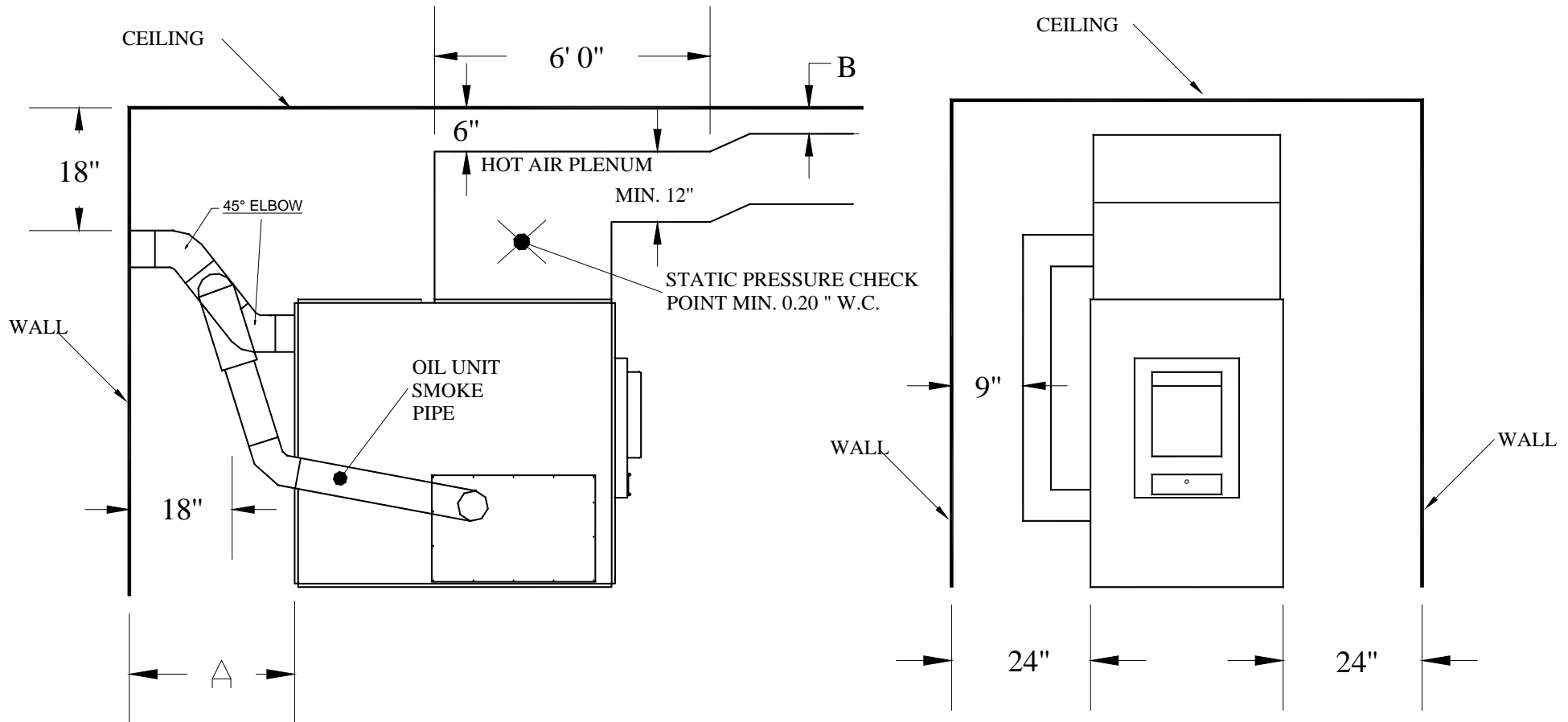

A = 29" ALL MODELS EXEPT CADDY = 24"
B = 2" ALL MODELS EXEPT CADDY = 1"

N.B. FOR AIR RETURN, RESPECT THE OPENING SURFACE OF THE OUTSIDE AIR PLENUM OF THE FURNACE.

C- POSITIONING THE APPLIANCE

For a safe and quiet operation, the furnace must be levelled in both directions. Give each "U" shape block, an equal support so that the weight is evenly distributed.

D- PIPE CONNECTOR AND DAMPER

The pipe connecting the furnace to the chimney must be as short as possible. The use of 45° elbows is highly recommended for a better evacuation of the smoke in the chimney for both the wood burning furnace and the oil burning unit (UH). The barometric damper provided with the appliance must be installed in the oil unit evacuation pipe, approximately 24" from the unit flue outlet of the unit.

TYPE OF FURNACE	(UH) OIL BURNING UNIT FLUE PIPE DIAMETER
PSG/UH 2000	5"
PSG/UH 3000 & UH-CADDY	5"
PSG/UH 4000	5"
PSG/UH 4500	6"

DIFFERENT INSTALLATIONS FOR PSG/UH-2000-4000-4500

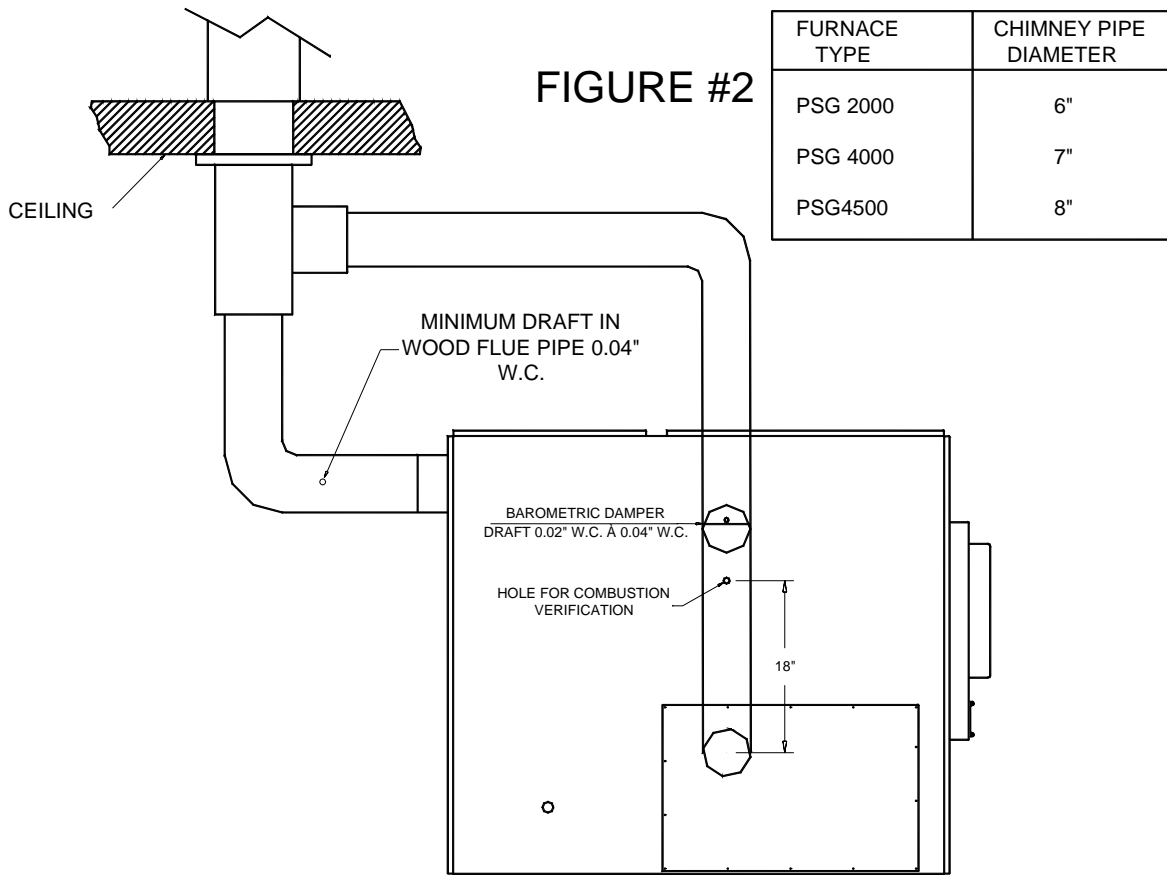
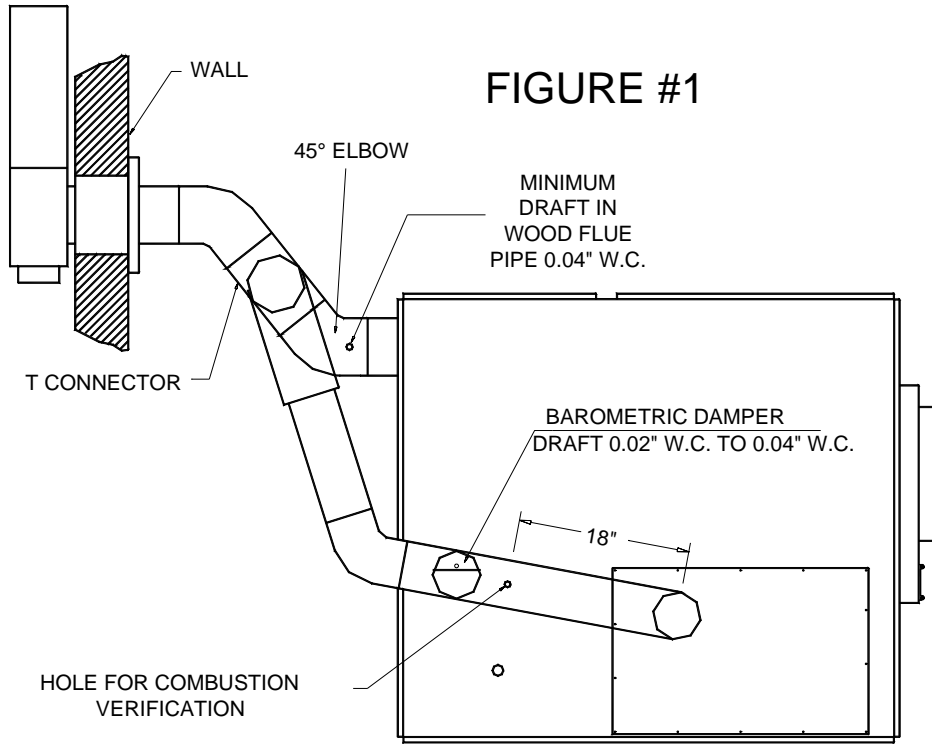

FOR PSG/UH-3000 AND UH-CADDY

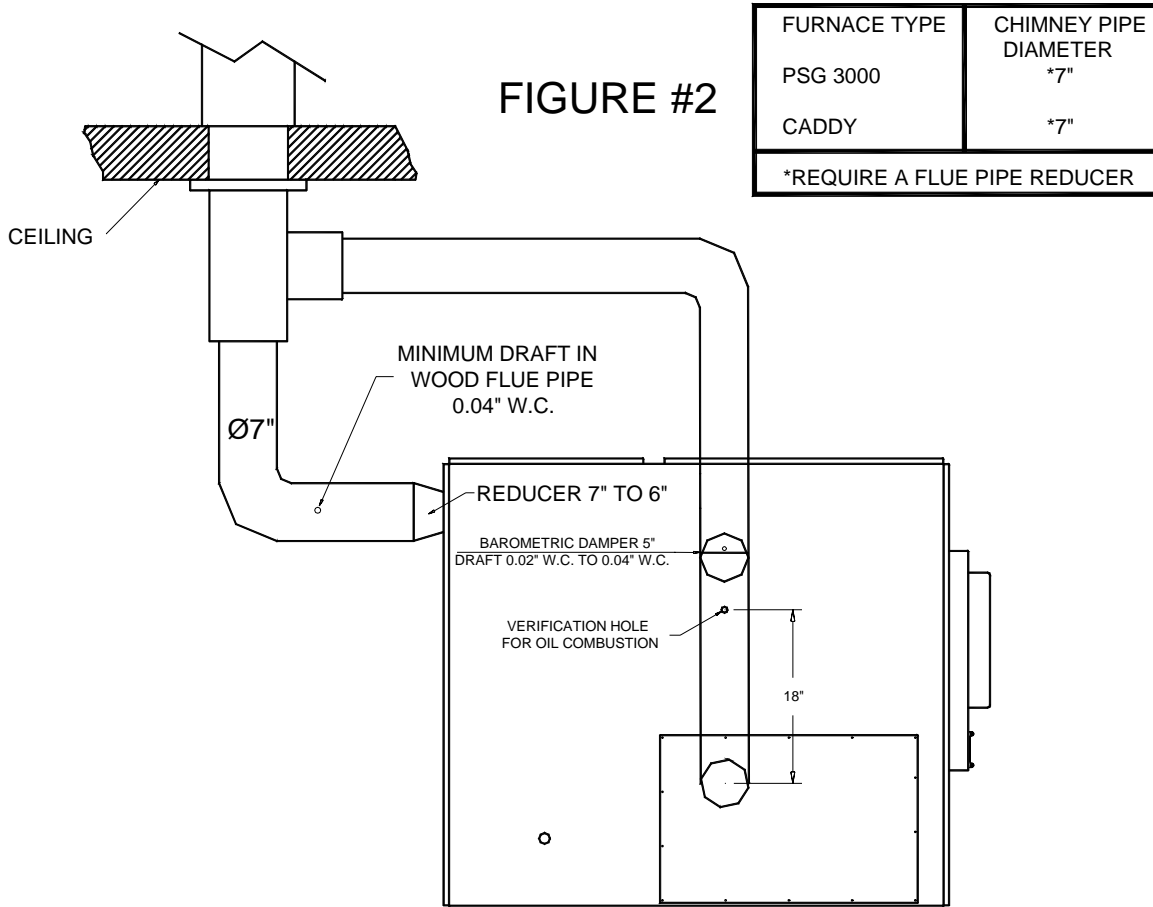
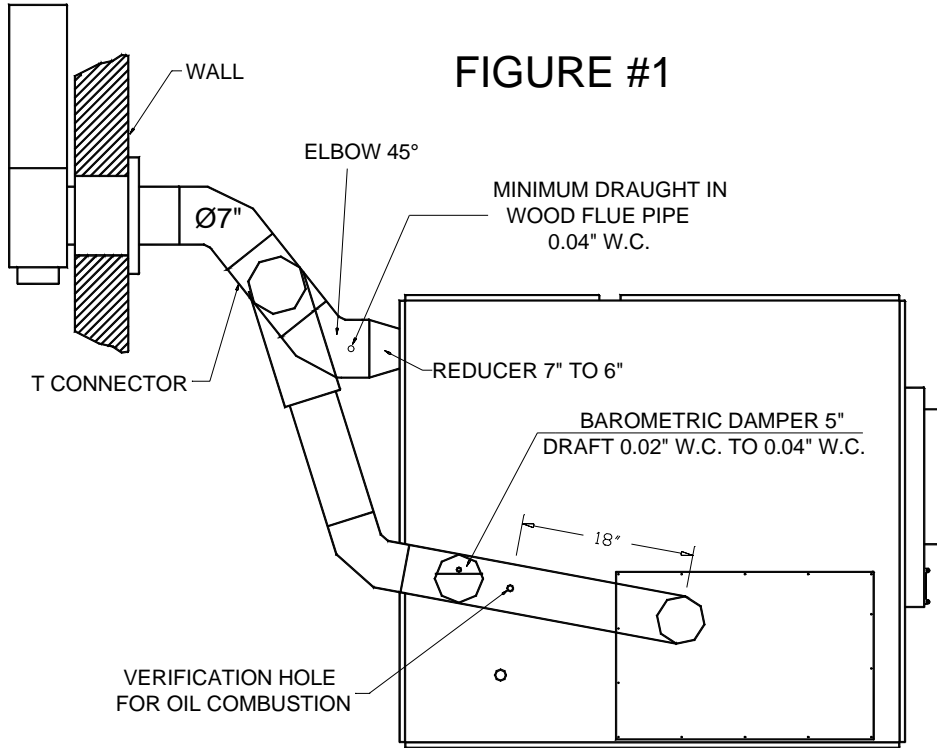

E- COMBUSTION AIR

Take note that an airtight house is liable to lack the fresh air needed for proper combustion, specially if you are using appliances that evacuate air from the house, such as:

- Range hood
- Air exchanger
- Clothes dryer
- Bathroom fan
- Central vacuum cleaning system

In that case, it is recommended to install a 4" fresh air inlet in the room or next to the room where the heating appliance is located (see drawing below); choose a wall which is not exposed to dominant winds, depending on the conditions surrounding your house.

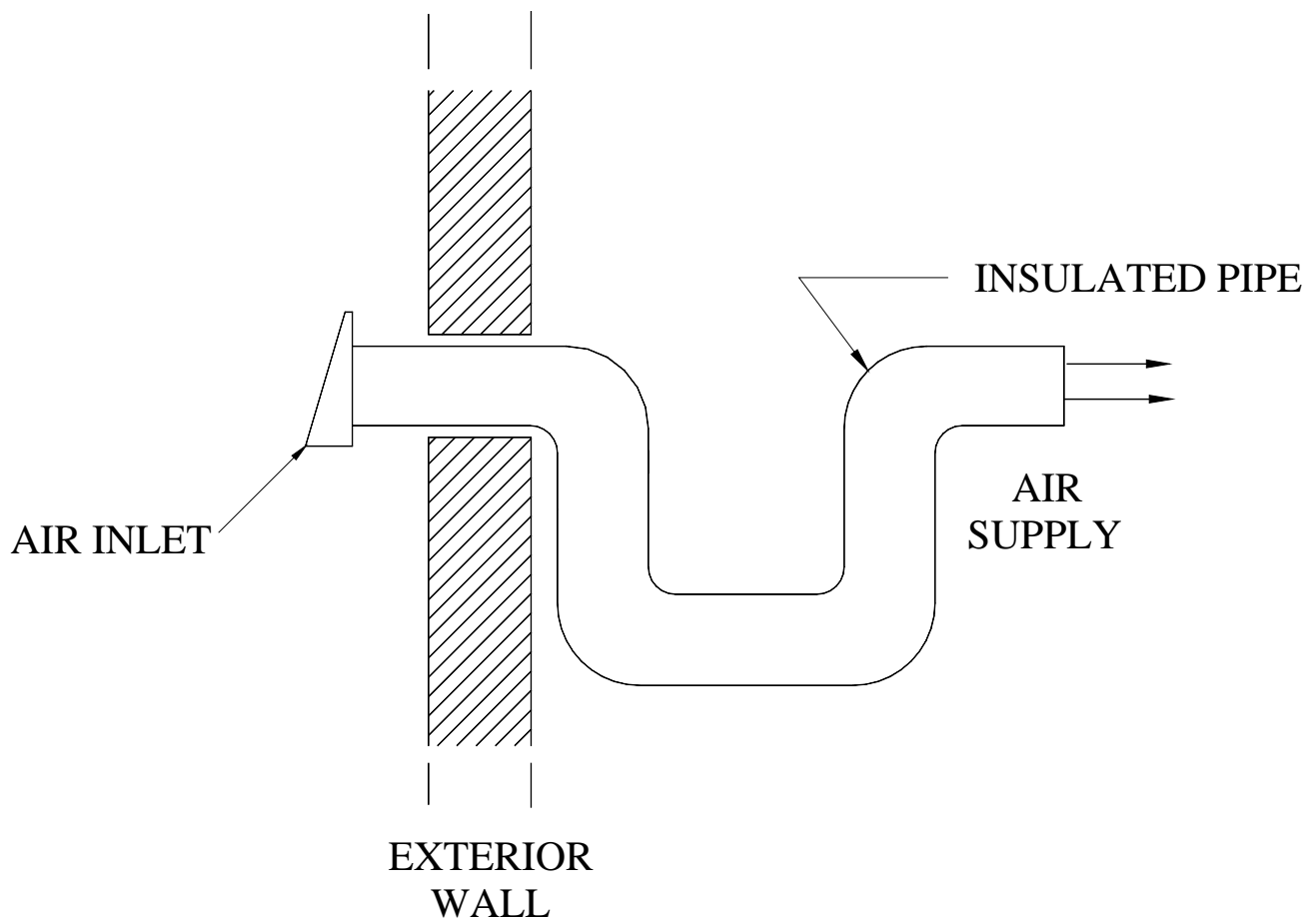

N.B. The owner is responsible for the salubrity of the premises in case of negative pressure or temporary negative pressure.

F- ELECTRIC COMPONENTS INSTALLATION

All the wires joining the electric components must have the proper length. Run the wires connecting the servo-motor to the relay-transformer away from surfaces that may get hot (see figure #1).

FIGURE #1

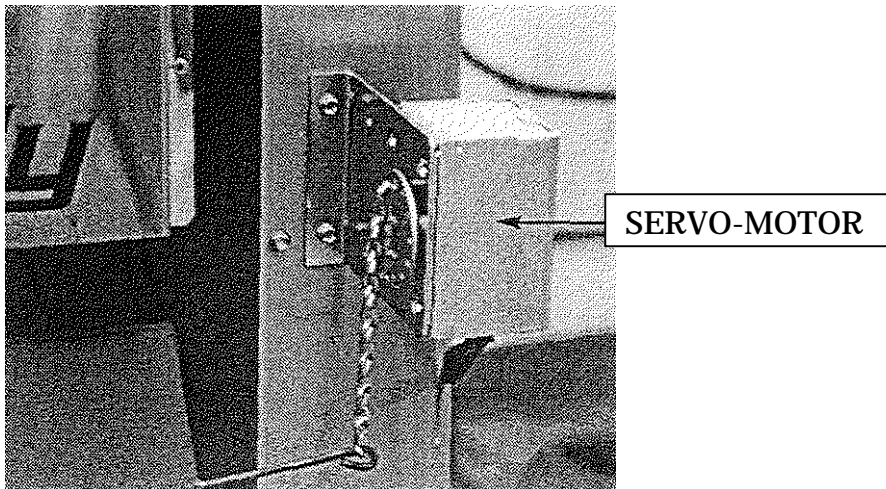

FAN LIMIT INSTALLATION ON PSG UH-2000-3000-4000 AND UH-CADDY MODELS

The wood fan limit control must be installed with the mounting bracket, in the warm air plenum on the left hand side of the appliance; two holes are pre-drilled on the edge to match the holes on the bracket (see fig. #3). The fan limit control for the oil unit must be installed on the lower left hand side removable panel, near the oil flue outlet; a 1" diameter hole is pre-punched to allow the insertion of the fan limit's sensor).

N.B. The oil burning fan limit control is the affixed to the junction box and relay-transformer (see figure #2).

FIGURE #2

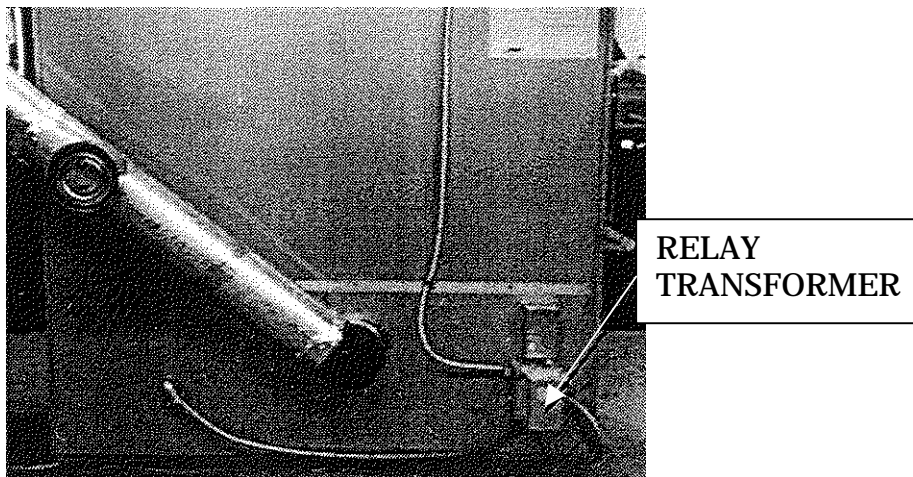
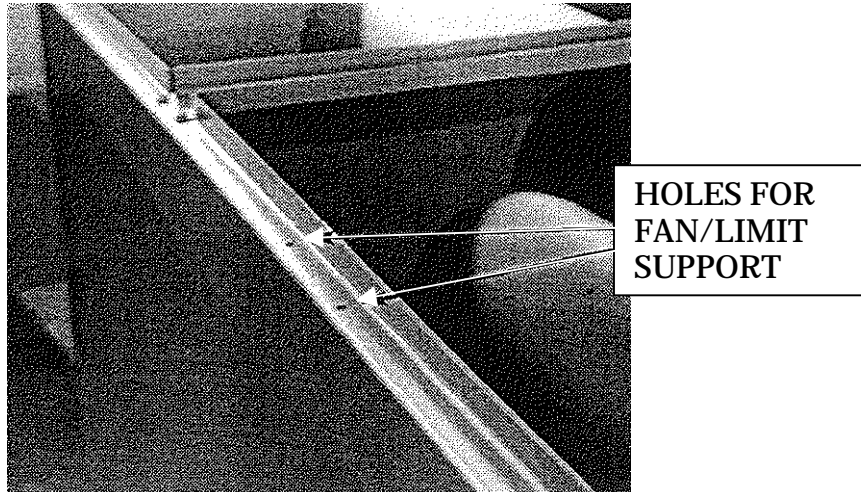

FIGURE #3



FAN LIMIT CONTROL INSTALLATION ON MODEL PSG/UH-4500

The wood unit fan limit control must be installed with the mounting bracket in the warm air plenum on the right hand side of the appliance (two holes are pre-drilled on the upper edge of the furnace to receive the mounting bracket). The fan limit control for the oil burning unit must be installed on the upper right part of the appliance's front panel (a 1" diameter hole is pre-punched in order to insert the fan limit's sensor in the furnace).

N.B. On the PSG/UH-4500, the wood burning fan limit control is the one that is attached to the junction box and relay-transformer.

G- ELECTRICAL WIRING

The whole wiring from the distribution panel to the heating unit shall comply with the applicable electrical standards and local codes. The unit should be connected to its own 15 amp/120VAC electric circuit (see electrical diagram on page 18).

H- THERMOSTAT

Both the wood and oil thermostats must be installed side by side on an interior wall, in a location where they are not affected by the air draft coming from the furnace's blower; they must be level and at least 55 inches above the floor.

I- FAN CONTROL

The fan limit control settings may vary according to the type of building and heating installation; the "fan off" setting is factory set at 100°F and this setting should allow a proper operation for most installations. The "fan on" setting should be positioned as close as physically possible to the "fan" off" setting.

In order for the blower to run for long enough periods, the "fan off" setting must not be set too high but too low a setting will result in undesirable cold air circulation. To modify this setting, turn the indicator to the desired position on the temperature scale of the fan limit control.

All adjustments of the controls must be performed by a qualified technician. The controls settings and the blower speeds must be set in accordance with the recommendations of the Warm Air Heating and Air Conditioning National Association.

To obtain a continuous air circulation during summer months, simply turn the manual switch on the fan limit control from the "auto" to the "manual" position.

J- COMBUSTION SAFETY CONTROL

The AFG type oil burner is equipped with an electronic control (# R7184B1032) including a pre-purge/post-purge function and a new more durable drive motor.

PRE-PURGE

When there is a call for heat, the burner's fan will run for 15 seconds before the actual ignition takes place to vent the combustion chamber and generate a proper draft. This will result in a smoother ignition of the oil burner.

SAFE OPERATION

If the flame goes out while the burner is running, the CAD cell will detect it; the control will then switch to the "RECYCLE" mode and cut the fuel supply to the burner for 60 seconds. After this delay, the control goes back to "IGNITION" mode. If the flame goes out 3 times in a row, the control will switch to the "LOCKOUT" mode to prevent a continuous cycling of the ignition process, which would cause a premature sooting of the combustion chamber and smoke pipe. To deactivate the "LOCKOUT" mode, press and hold the reset button of the control for 30 seconds.

A green diagnostic LED on the control has four states:

- On = Flame present
- Off = No flame
- 2 seconds On, 2 seconds Off = "Recycle" mode
- 1/2 second On, 1/2 second Off = "Lockout" mode TEMPORARY SHUT-OFF

By pressing and holding the reset button, the burner will shut-off until the reset button is released. Then, the control will start over at the beginning of the normal cycle.

FOR ADDITIONAL INFORMATIONS ON OPERATION SEQUENCES OF THE BURNER, CONSULT THE BURNER INSTRUCTION MANUAL.

K- COMBUSTION ADJUSTMENT AND VERIFICATION

To enjoy the efficiency of our oil burning units, you must respect the following criterias:

TOOLS REQUIRED:

- DRAFT GAUGE
- SMOKE TESTER
- PUMP PRESSURE GAUGE
- NOZZLE AND ELECTRODES POSITION TESTER
- COMBUSTION TESTER

CHECK LIST:

- SELECTION OF NOZZLE AND HEAD
- NOZZLE / ELECTRODES POSITION IN RELATION TO THE HEAD
- PUMP PRESSURE
- LOW FIRING RATE BAFFLE (INSIDE THE BURNER) REQUIRED FOR UH-2000-3000-4000 AND UH-CADDY. NOT REQUIRED FOR UH-4500
- FAN SPEED
- BAROMETRIC DAMPER POSITION

COMBUSTION VERIFICATION PROCEDURE:

- A- DRILL A 9/32" DIAMETER HOLE IN THE EVACUATION PIPE APPROXIMATELY 18" FROM THE OUTLET.
 - B- CLOSE THE DOOR AND THE AIR INTAKE(S) OF THE WOOD BURNING FURNACE.
 - C- LIGHT THE BURNER FOR AT LEAST 10 TO 15 MINUTES.
 - D- OVER THE FIRE DRAUGHT = -0.01 TO -0.02 W.C. (THE DRAFT OVER THE FIRE MUST BE MEASURED IN THE OPENING IN THE PULSATION TRAP).
 - E- SMOKE TEST BETWEEN 0 AND 1 ON THE SHELL BACHARACH SCALE (TRACES).
 - F- DRAFT IN THE CHIMNEY =-0.02 TO -0.04 W.C.
 - G- PERCENTAGE OF EXCESS AIR = 20 TO 40%, 12% CO₂, 4.6% O₂.
 - H- AVERAGE EFFICIENCY OF 80 TO 85 %.
 - I- TIGHTEN ALL THE LOCKING SCREWS AFTER COMPLETING THE FINAL ADJUSTMENT.
- N.B. – The barometric damper provided with the appliance must be properly installed on the flue pipe of the oil burning unit. The purpose of the damper is to adjust the draft in the evacuation pipe of the oil burning unit to the recommended level. Since the evacuation pipe of the oil burning unit is connected on the evacuation pipe of the wood burning furnace, the minimum draft to be respected is 0.04" W.C. in the evacuation pipe of the wood burning side, at all time. ***In fact, a barometric damper that would be opened too wide could cause an important loss of draft in the evacuation pipe of the wood burning furnace.***

L- ELECTRODES SETTING

The electrodes must be adjusted by a qualified technician. A proper positioning of the electrodes is important to get an efficient lighting of the oil.

ELECTRODE SETTING FOR "F" HEAD

MODEL:	DIMENSION "N"
F0 to F31	1/16"
F30 to F300	1/8" – 5/32"

WARNING:

1. REFER TO THE RATING PLATE FOR THE PUMP PRESSURE AND THE NOZZLE TYPE.
2. REFER TO THE BECKETT INSTRUCTION MANUAL FOR DETAILS ON THE BECKETT PUMP.
3. FOR ELECTRODES SETTING SEE THE BECKETT MANUAL.
4. FOR THE START-UP AND ADJUSTMENT OF THE BURNER SEE THE INSTRUCTION MANUAL OF THE BURNER.
5. IN CASE OF BURNER FAILURE, REFER TO THE BURNER MANUAL.

4- APPLIANCE START-UP

The start-up must be performed by a qualified technician. Make sure the installation is completed and the oil tank has been filled up. The oil line must also have been purged.

**CAUTION: CLOSE THE BLOWER COMPARTMENT ACCESS
PANEL BEFORE STARTING THE BURNER.**

5- PROLONGED CLOSING

- A) Cut off the electric circuit
- B) Close the oil shut-off valve

NOTE: The shut-off valve must be closed when the appliance is out of service for a prolonged period of time.

6- MAINTENANCE (Including filters)

At the beginning of heating season, have the complete installation inspected by a qualified service man, especially the lighting system and the controls.

NOTE: THE UNIT'S MAINTENANCE, REPAIRS AND THE CLEANING OF THE OIL FILTER MUST BE DONE BY A QUALIFIED TECHNICIAN.

SERVICE:

Before calling for service, first check the following:

- Fuel supply
- Electric fuses or breakers
- Thermostat setting
- Fan limit controls settings
- The state of the green diagnostic LED on the burner control (see section: 3. APPLIANCE INSTALLATION, J- COMBUSTION SAFETY CONTROL).

MAINTENANCE:

WARNING: *Turn off electric power supply before servicing the unit.*

1. The furnace, the burner and the flue pipe should be cleaned at least once a year.
2. The nozzle should be inspected and replaced if needed.
Handle with care to avoid damaging its surface.
3. The electrodes should be adjusted as indicated in the burner manual.
4. Lubricate the burner motor bearings twice a year.
(2 or 3 drops of SAE 20 non detergent lubricating oil).
5. The oil filter should be replaced annually

Burner no.: _____ Model: _____ Date of installation: _____

Service Telephone no.: Day: _____ Night: _____

Dealer's name and address: _____

TEST REPORT :

CO₂ _____% Temp. at stack: _____ Draft at stack: _____ w.c.

Nozzle output: _____ GPH Smoke colour: _____

Inspected by : _____

FILTERS

The furnace should never be operated without filters.

This applies especially to temporary heating during construction period. Operating the furnace without filters would allow dust and other particles in the air to circulate freely and to penetrate into the fan and motor carters causing some defects. Clean and replace filters as often as required.

Note : The operation cost is higher when using a dirty filter.

7- ELECTRICAL DIAGRAMS

WIRING DIAGRAM FOR PSG/UH – 2000 – 3000 - 4000 AND CADDY

(The location of the wood limit is on the plenum and the location of the oil limit is on the panel towards exhaust pipe)

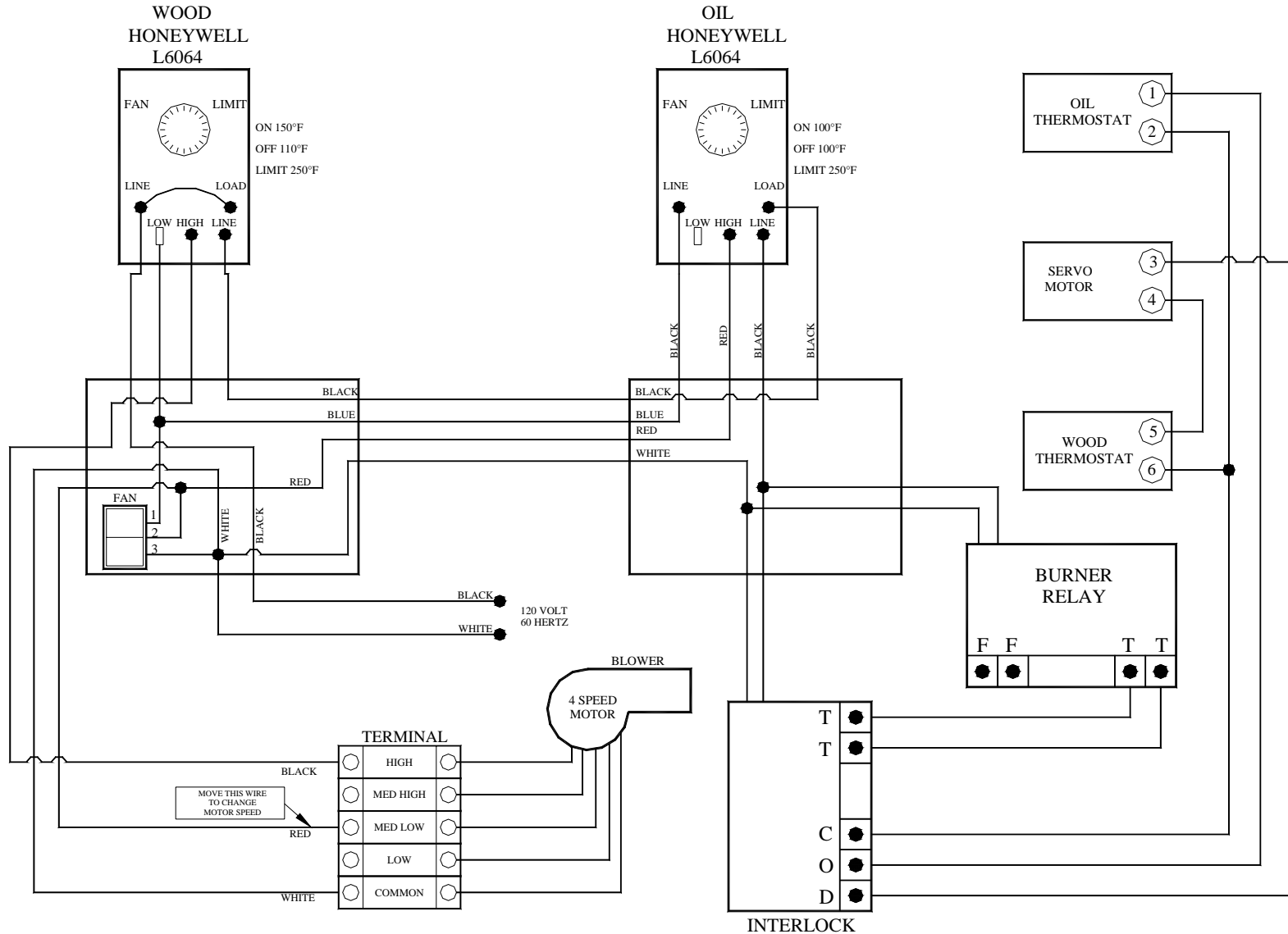

REVISION AUGUST 18TH 2005

NOTE: ALL WIRES ON OIL
LIMIT ARE TEW 105° 600V
14AWG TYPE

8- TECHNICAL DATA

PSG/UH – 2000 – 3000 – 4000 - 4500

MODEL	BURNER TYPE	BTU AT PLENUM	NOZZLE	HEAD	STATIC PLATE	PRESSURE AT THE PUMP	H.P. MOTOR FAN
UH-2000	BECKETT AFG	85,000	0.65, 70° A (DELAVAN)	F3	2 3/4	110 PSI	1/3 H.P.
UH-3000	BECKETT AFG	91,000	0.65, 70° A (DELAVAN)	F3	2 3/4	110 PSI	1/3 H.P.
UH-4000	BECKETT AFG	120,000	0.75, 70° A (DELAVAN)	F3	2 3/4	110 PSI	1/3 H.P.
UH-4500	BECKETT AFG	150,000	1.0, 70° W (DELAVAN)	F3	2 3/4	120 PSI	3/4 H.P.

UH – CADDY

MODEL	BURNER TYPE	BTU AT PLENUM	NOZZLE	HEAD	STATIC PLATE	PRESSURE AT THE PUMP	H.P. MOTOR FAN
UH-CADDY	BECKETT AFG	91,000	0.65, 70° W (DELAVAN)	F3	2 3/4	120 PSI	1/3 H.P.
UH-CADDY	RIELLO/F3	91,000	0.65, 70° W (DELAVAN)	---	---	120 PSI	1/3 H.P.
UH-CADDY	AERO/FAF C-2X	91,000	0.75, 70° W (DELAVAN)	---	---	120 PSI	1/3 H.P.

For any additional informations, consult the rating plate on the left hand side of the appliance.



1700, rue Léon-Harmel, Québec (Québec) G1N 4R9
 tel. : (418) 527-3060 fax : (418) 527-4311
 e-mail : tech@sbi-international.com web site : www.psg-distribution.com

LIMITED LIFETIME WARRANTY

The PSG warranty extends only to the original consumer purchaser and is not transferable. This warranty covers brand new products only, which have not been altered, modified nor repaired since shipment from factory. Proof of purchase (dated bill of sale), model name and serial number must be supplied when making any warranty claim to your PSG dealer

This warranty applies to normal use only. Damages caused by misuse, abuse, improper installation, lack of maintenance, over firing, negligence or accident during transportation are not covered by this warranty.

This warranty does not cover any scratch or discoloration caused by over firing, abrasives or chemical cleaners. Any defect or damage caused by the use of unauthorized parts or others than original parts void this warranty.

An authorized qualified technician must perform the installation in accordance with the Instructions supplied with this product and all local and national building codes. Any service call related to an improper installation is not covered by this warranty.

Returned products are to be shipped prepaid to PSG for investigation. If a product is found to be defective, PSG will repair or replace such defect and reasonable transportation fees will be refund. Repair work covered by the warranty, executed at the purchaser domicile by an authorized qualified technician requires the prior approval of PSG. Labour cost and repair work to the account of PSG are based on predetermined rate schedule and must not exceed the wholesale price of the replacement part.

PSG at its discretion may decide to repair or replace any part or unit after inspection and investigation of the defect. PSG may, at its discretion, fully discharge all obligations with respect to this warranty by refunding the wholesale price of any warranted but defective parts

PSG shall in no event be responsible for any special, indirect, consequential damages of any nature, which are in excess of the original purchase price of the product.

DESCRIPTION	WARRANTY APPLICATION	
	PARTS	LABOUR
Combustion chamber (weldings only)	Lifetime	5 years
Perforation caused by rust	5 years	n/a
Stainless steel baffle	5 years	1 year
Carbon steel baffle	2 years	1 year
Handle assembly	5 years	n/a
Ash drawer	Lifetime	1 year
Cast iron parts	5 years	1 year
Ceramic glass (thermal breakage only)	1 year	n/a
Paint, refractory bricks, gasket, blower, thermal switch (thermodisc), rheostat and burner	1 year	n/a
Plating	1 year	n/a

Shall your unit or a components be defective, contact immediately your **PSG** dealer. Prior to your call make sure you have the following information necessary to your warranty claim treatment:

- You name, address and telephone number;
- Bill of sale, dealer's name;
- Serial number and model name as indicated on the nameplate fixed to the back of your unit;
- Nature of the defect and any relevant information.

Before shipping your unit or defective component to our plant, you must obtain from your PSG dealer an Authorization Number. Any merchandise shipped to our plant without authorization will be refused automatically and returned to sender.